

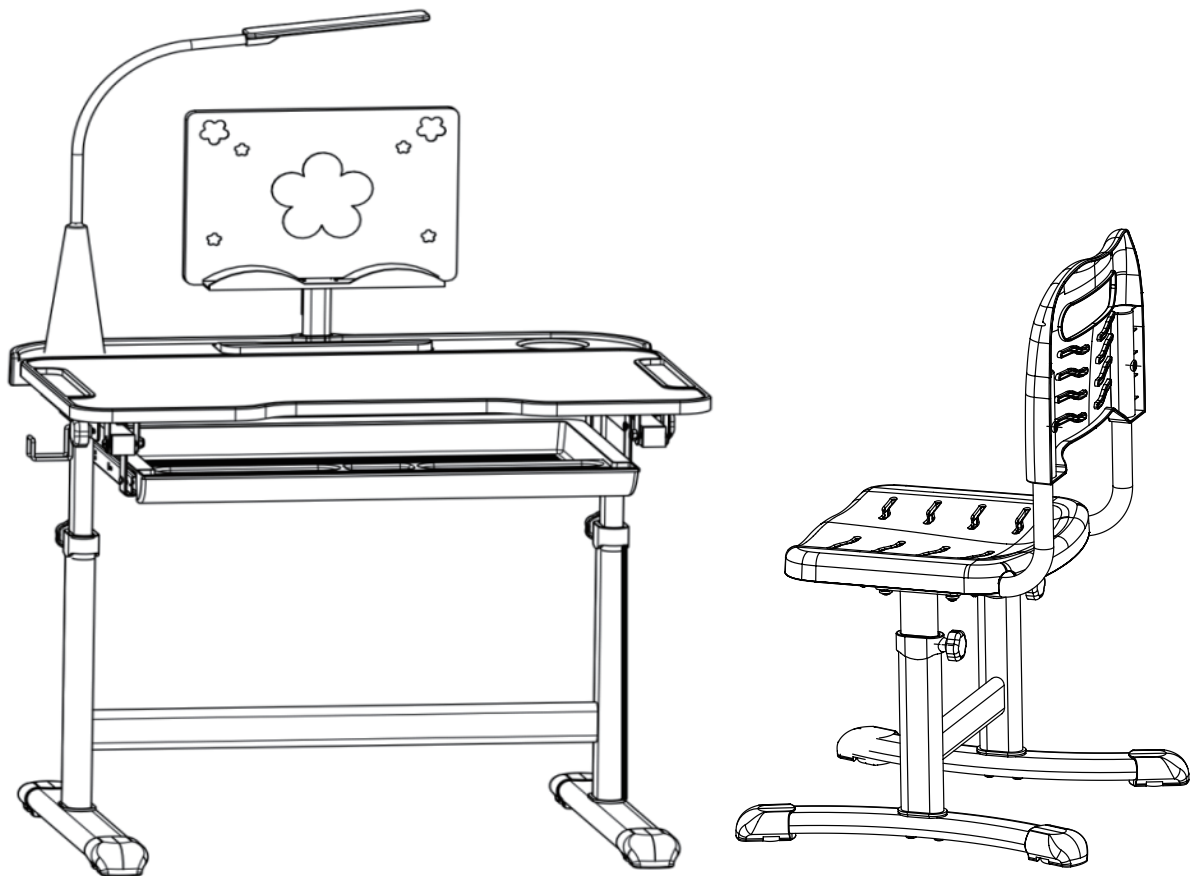

IN240500226V01_US_CA

312-062V81



ASSEMBLY INSTRUCTION INSTRUCTIONS D'ASSEMBLAGE

EN: **WARNING:** Suitable for ages 3-12 years;

Maximum Weight Capacity of Chair: 100 Kg/seat; Table: 80 Kg.

FR: **ATTENTION:** Convient aux enfants de 3-12 ans;

Poids maximum admissible de la chaise: 1000 Kg/siège; Table: 80 kg.

**EN: IMPORTANT, RETAIN FOR FUTURE REFERENCE: READ CAREFULLY.
FR: IMPORTANT: A LIRE ATTENTIVEMENT ET A CONSERVER POUR VOUS Y
REFRERER ULTERIEUREMENT**

EN

IMPORTANT! READ CAREFULLY AND KEEP FOR FUTURE REFERENCE.

WARNING:

1. CHOKING HAZARD—Small parts. Not for children under 3 years.
2. Only allowed for adults to install, keep children away.
3. To be used under the direct supervision of an adult.
4. Place it on a flat and clean floor, Check all the parts are well connected before use.
5. DO NOT place this product near a window as it can be used as a step by the child and cause the child to fall out of the window.
6. Be aware of the risk of open fires and other sources of strong heat in the vicinity of the product.
7. DO NOT place this product near a window where cords from blinds or curtains could strangle a child.
8. DO NOT to use the seating if any part is broken, torn or missing and use only spare parts approved by the manufacturer.

MAINTENANCE & CARE

- A. Keep all instructions and parts relating to this product for future reference.
- B. Please wipe down with a dry or damp cloth.

FR

IMPORTANT! LIRE ATTENTIVEMENT ET CONSERVER POUR RÉFÉRENCE ULTÉRIEURE.





ATTENTION

1. RISQUE D'ÉTOUFFEMENT - Petites pièces. Déconseillé aux enfants de moins de 3 ans.
2. Installation par des adultes uniquement, tenir les enfants à l'écart.
3. À utiliser sous la surveillance directe d'un adulte.
4. Posez-le sur un sol plat et propre. Vérifiez que toutes les pièces sont bien connectés avant toute utilisation.
5. NE PAS placer ce produit près d'une fenêtre ; il pourrait être utilisé comme marchepied par un enfant et le faire tomber par la fenêtre.
6. Soyez conscient du risque de feu ouvert et d'autres sources de forte chaleur à proximité du produit.
7. NE PAS placer ce produit près d'une fenêtre où les cordons des stores ou des rideaux pourraient étrangler un enfant.
8. NE PAS utiliser le siège si une pièce est cassée, déchirée ou manquante et n'utiliser que des pièces de rechange approuvées par le fabricant.



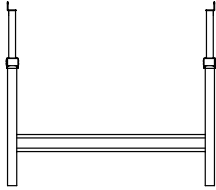
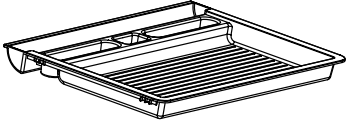
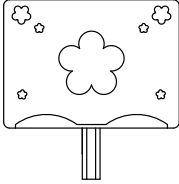
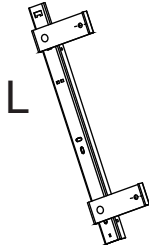
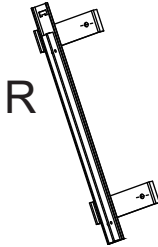
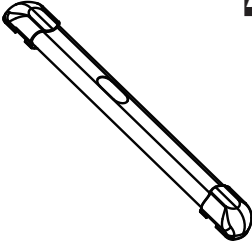
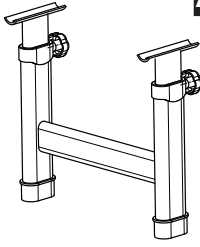
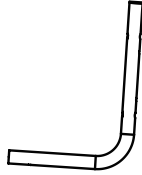

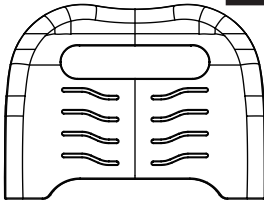
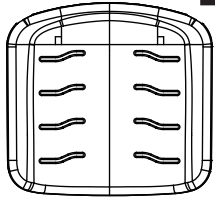

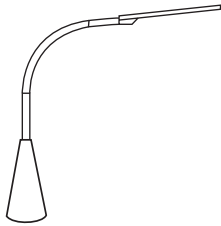

ENTRETIEN ET MAINTENANCE

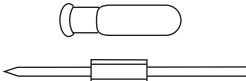
- A. Conservez toutes les instructions et les pièces relatives à ce produit pour pouvoir vous y référer ultérieurement.
- B. Veuillez essuyer avec un chiffon sec ou humide.

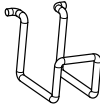
PARTS

 <p>A1x1</p>	 <p>A2x1</p>	 <p>A3x1</p>
 <p>A4x1</p>	 <p>A5x1</p>	 <p>A6x1</p>
 <p>A7x2</p>	 <p>A10x1</p>	 <p>A11x2</p>
 <p>A12x1</p>	 <p>A13x1</p>	 <p>A14x1</p>
 <p>A15x2</p>	 <p>A16x1</p>	

HARDWARE

 <p>B2x1</p>	 <p>B3x1</p>	 <p>B4x1</p>	 <p>B6x6</p> <p>Spare</p>
 <p>B7x2</p> <p>Spare</p>	 <p>B8x2</p> <p>Spare</p>	 <p>B9x4</p> <p>M5*20</p>	 <p>B10x4</p> <p>+1(spare)</p>
 <p>B12x4</p> <p>+1(spare)</p>	<p>M4*8:</p>		

Desk Assembly /Assemblage du Bureau/Montage des Tisches/Montaje de escritorio/Assemblaggio della Scrivania:

B6 x 4 (Pre installed)

B7 x 4 (Pre installed)

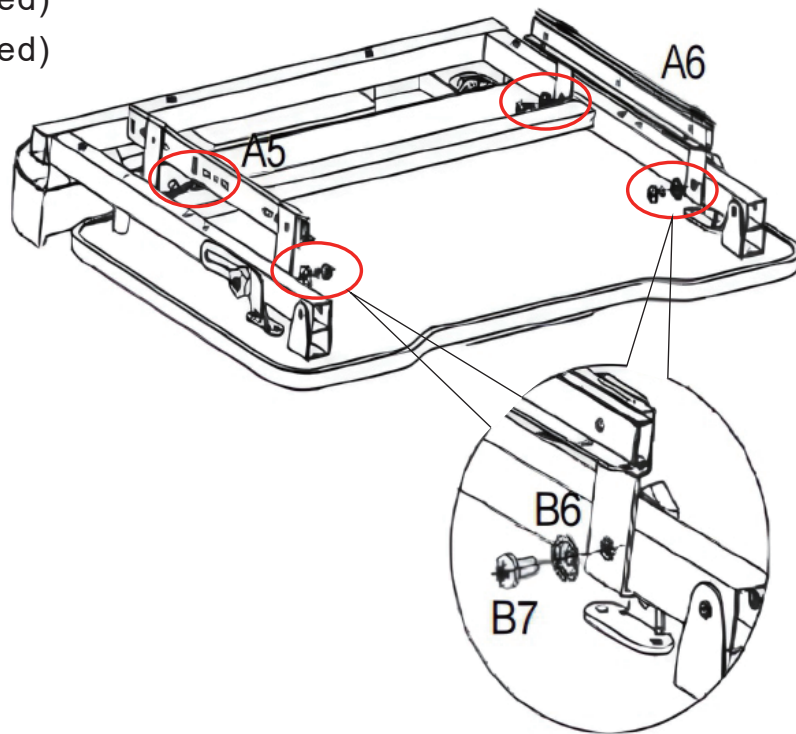

B12 x 4

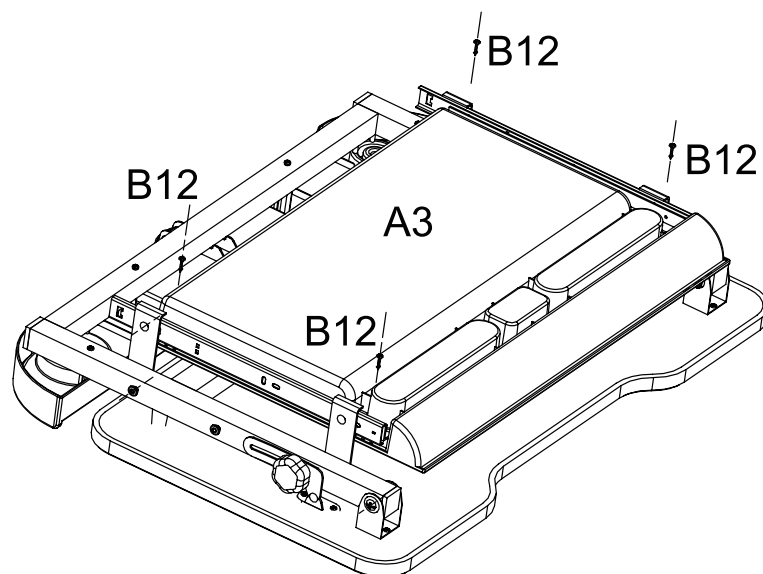

B6 x 4 (Pre installed)
B8 x 4 (Pre installed)

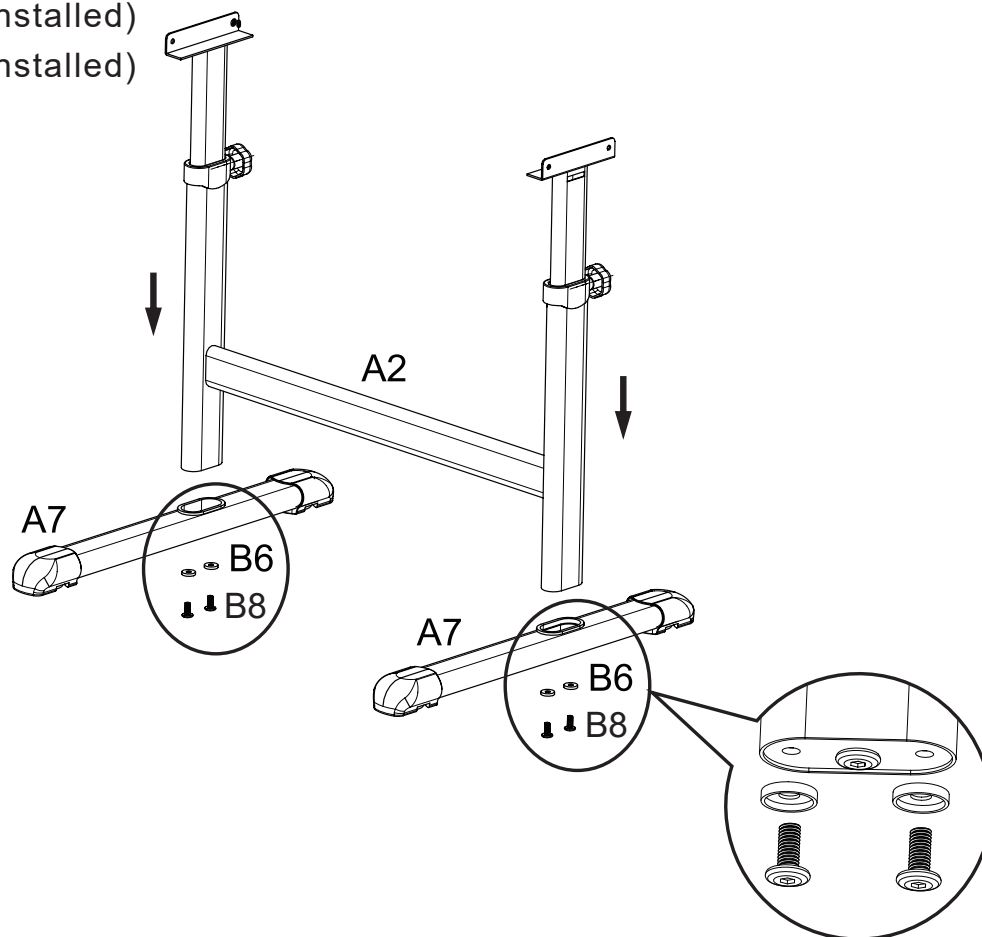

B6 x 4 (Pre installed)
B7 x 4 (Pre installed)

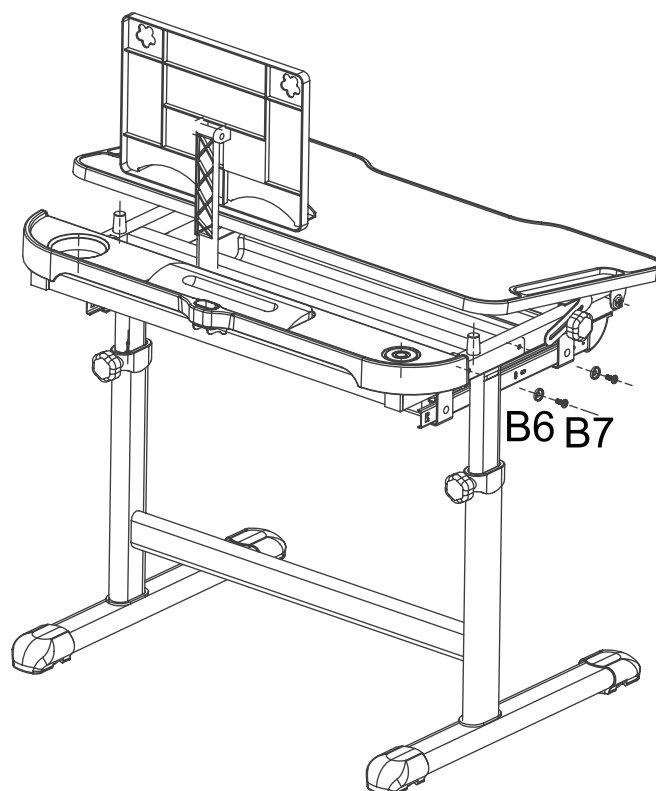

B4 x 1

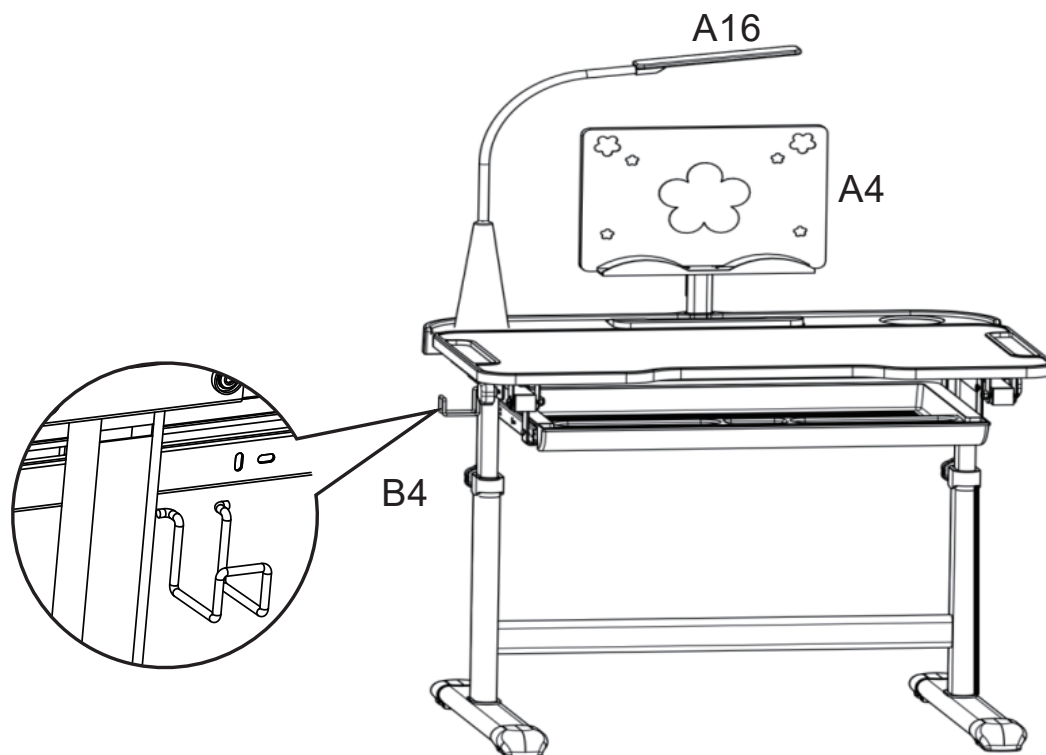

Chair Assembly/Assemblage de la Chaise/Zusammenbau des Stuhls/Montaje de silla/Assemblaggio della scrivania:

B6 x 4 (Pre installed)

B9 x 4

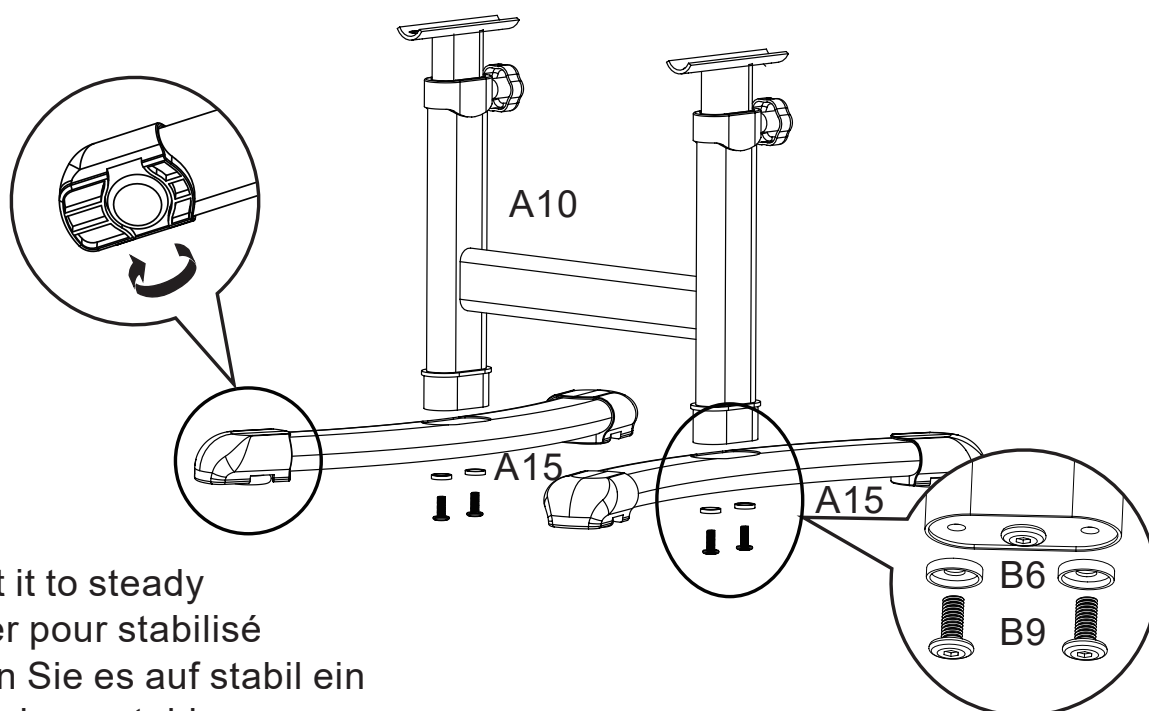

Adjust it to steady
 Ajuster pour stabilisé
 Stellen Sie es auf stabil ein
 Ajustarla a estable
 Regolare fino alla stabilità

B6 x 4 (Pre installed)
B8 x 4 (Pre installed)

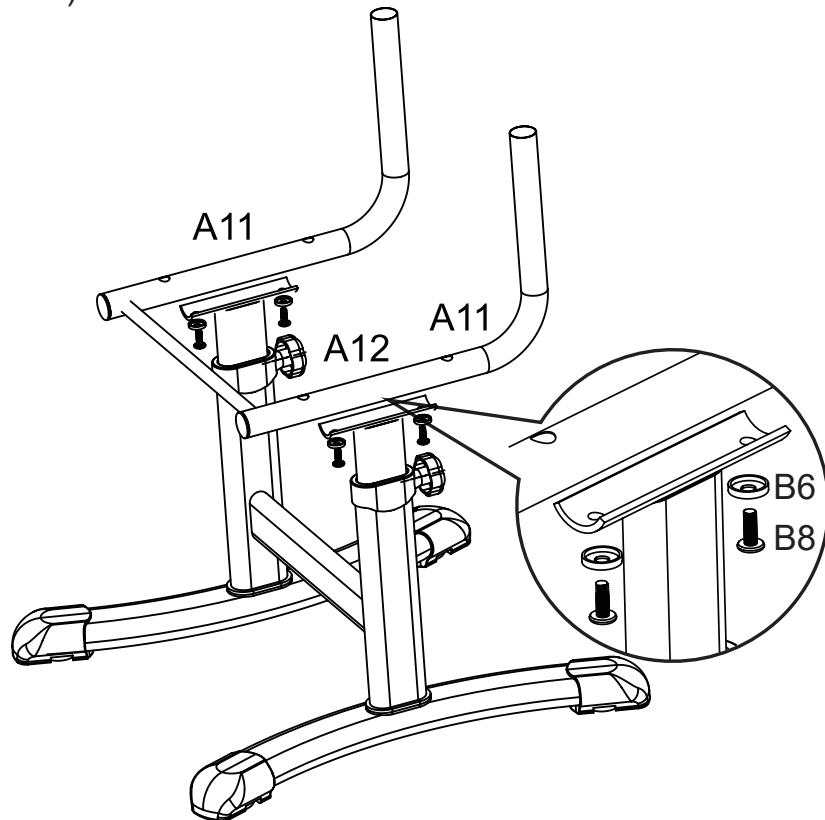

B10 x 4

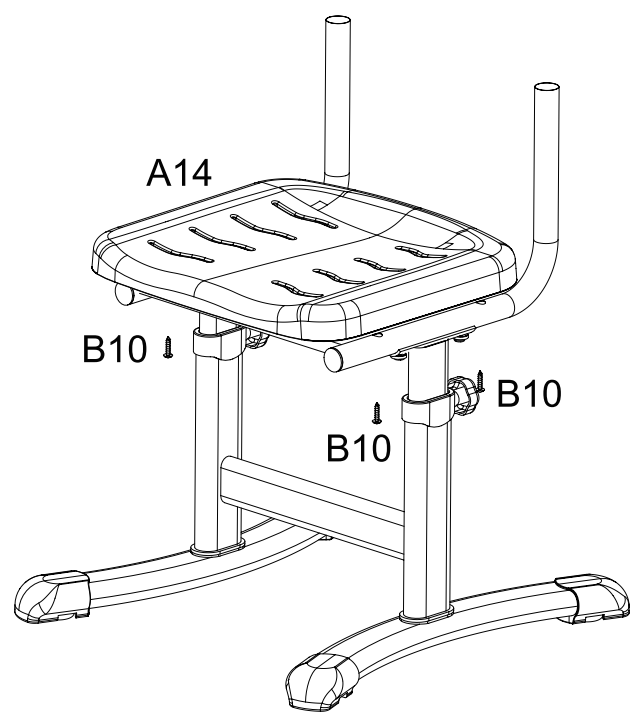

B6 x 2(Pre installed)
B7x 2(Pre installed)

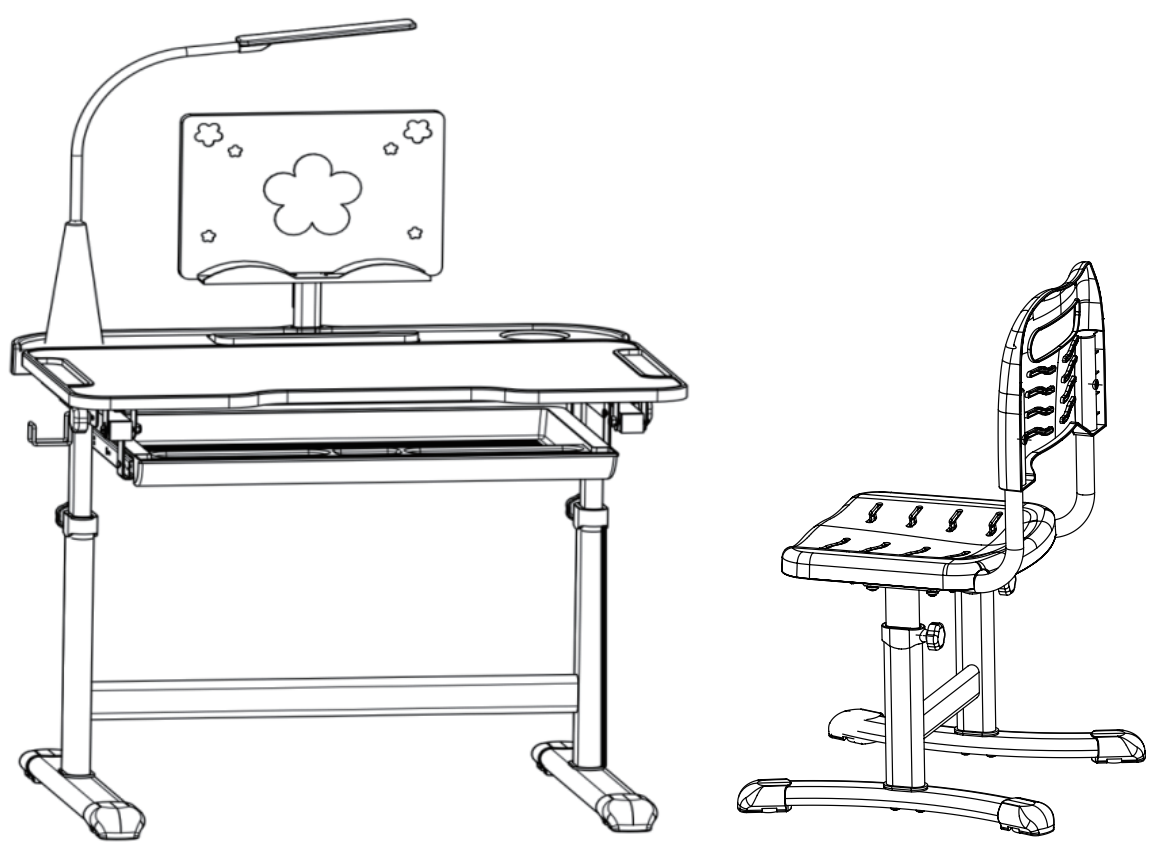
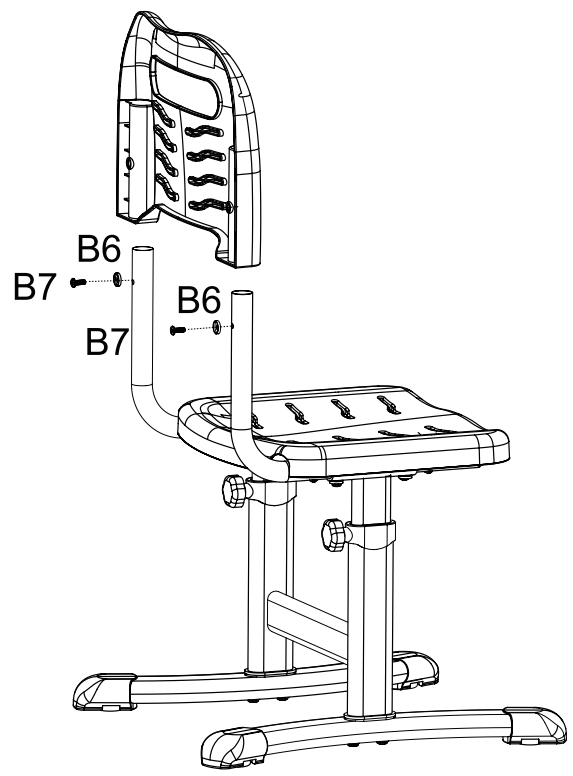

Step 1: Loosen the screws

Step 2: Step on the legs of the table

Step 3: Lift the tabletop

If you need to lower the tabletop, lift the tabletop to the highest point and then lower it down.

Étape 1: Desserrer les vis

Étape 2: Mettre les pieds de la table en place

Étape 3: Soulever le plateau de la table

Si vous souhaitez abaisser le plateau, soulevez le plateau jusqu'au point le plus haut, puis abaissez-le.

Schritt 1 : Lösen Sie die Schrauben

Schritt 2 : Stellen Sie sich auf die Beine des Tisches

Schritt 3 : Heben Sie die Tischplatte an

Wenn Sie die Tischplatte absenken müssen, heben Sie die Tischplatte bis zum höchsten Punkt an und senken Sie sie dann ab.

Paso 1: Afloje los tornillos.

Paso 2: Pise las patas del escritorio.

Paso 3: Levante la superficie del escritorio. Si necesita bajar la superficie del escritorio, levántela hasta el punto más alto, entonces bájela.

Passaggio 1 : Allentare le viti

Passaggio 2 : Metti piedi sugli stabilizzatori della scrivania

Passaggio 3 : Sollevare il piano superior

Se devi abbassare il piano della scrivania, sollevare il piano fino al punto più alto e poi abbassarlo.

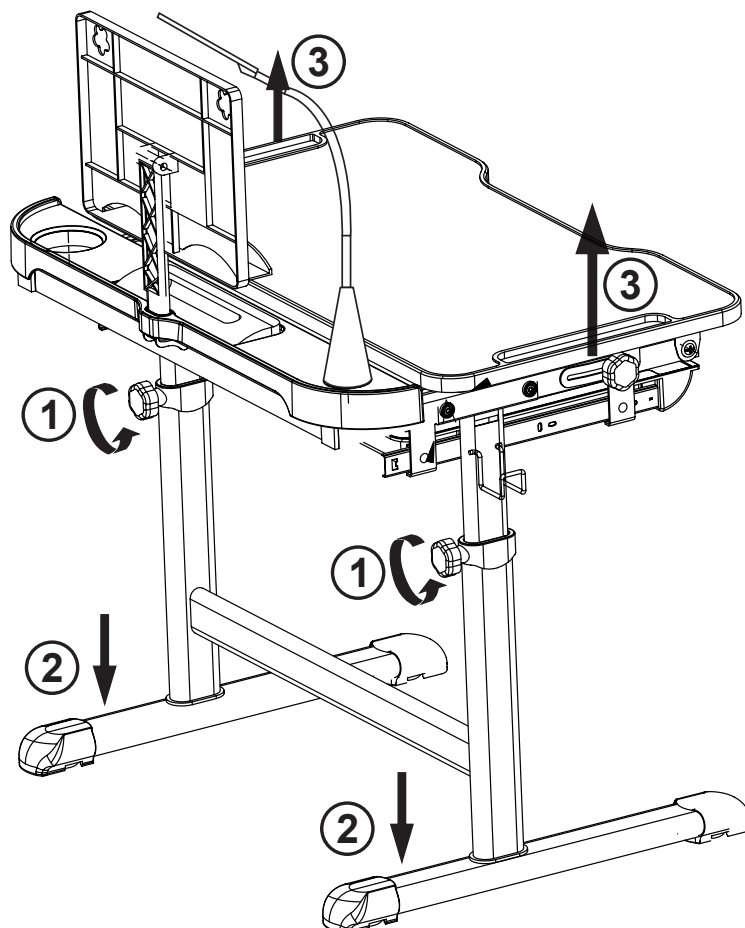

Step 1: Loosen the screws

Step 2: Step on the foot of the chair

Step 3: Lift the seat

If you need to lower the seat, lift the seat to the highest point and then lower it down.

Étape 1 : Desserrer les vis

Étape 2 : Mettre les pieds de la chaise en place

Étape 3 : Soulever le plateau de la table

Si vous souhaitez abaisser le siège, soulevez le siège jusqu'au point le plus haut, puis abaissez-le.

Schritt 1 : Lösen Sie die Schrauben

Schritt 2 : Stellen Sie sich auf den Fuß des Stuhls

Schritt 3 : Heben Sie den Sitz an

Wenn Sie die Sitzfläche absenken müssen, heben Sie die Sitzfläche bis zum höchsten Punkt an und senken Sie sie dann ab.

Paso 1: Afloje los tornillos

Paso 2: Pise las patas de la silla.

Paso 3: Levante el asiento.

Si necesita bajar el asiento, levántelo hasta el punto más alto, entonces bájelo.

Passaggio 1 : Allentare le viti

Passaggio 2 : Metti piedi sui piedini del sedile

Passaggio 3 : Sollevare la sedile

Se devi abbassare il sedile, sollevare il sedile fino al punto più alto e poi abbassarlo.

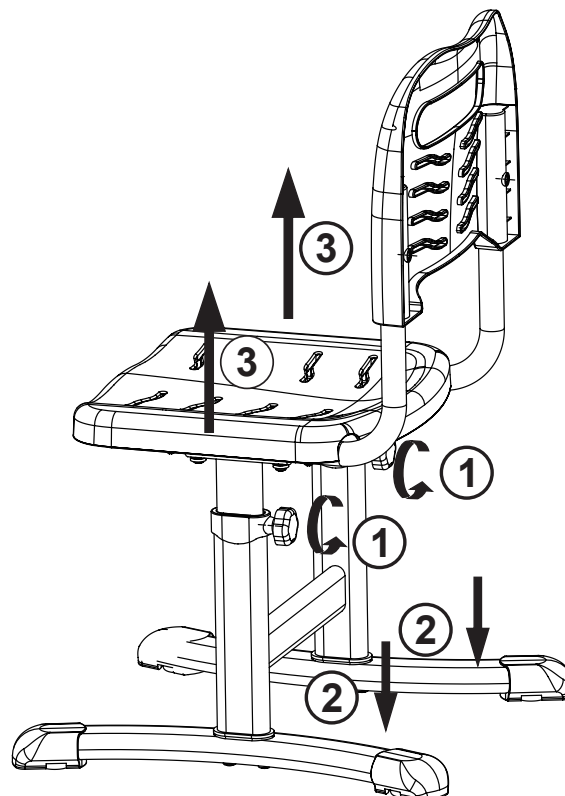

US

If you have any questions, please contact our customer care center.
Our contact details are below:



001-877-644-9366



customerservice@aosom.com

Imported by Aosom LLC
27150 SW Kinsman Rd Wilsonville, OR 97070 USA
MADE IN CHINA

CA

If you have any questions, please contact our customer care center.
Our contact details are below:

Si vous avez la moindre question, veuillez contacter notre centre d'assistance à la clientèle.
Nos coordonnées sont les suivantes:



416-792-6088



customerservice@aosom.ca

Imported by Aosom Canada Inc.
7270 Woodbine Avenue, Unit 307, Markham, Ontario Canada
L3R 4B9
MADE IN CHINA

Importé par Aosom Canada Inc.
7270 Woodbine Avenue, unité 307, Markham, Ontario Canada
L3R 4B9
FABRIQUÉ EN CHINE