

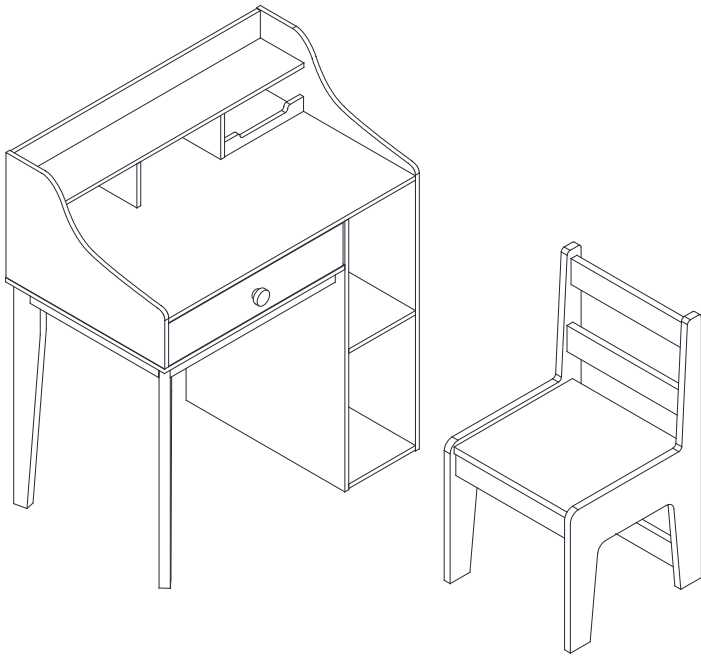

IN240600118V01_US_CA

312-126V80



! WARNING:
Assembly by an adult.



EN: WARNING: Suitable for ages 3+ years; Maximum Weight Capacity of Chair: 35 Kg.

FR: ATTENTION: Convient aux enfants de 3+ ans; Poids maximum admissible de la chaise: 35 Kg.

EN IMPORTANT, RETAIN FOR FUTURE REFERENCE: READ CAREFULLY.

FR IMPORTANT : A LIRE ATTENTIVEMENT ET A CONSERVER POUR VOUS Y REFERER ULTERIEUREMENT.

FRANÇAIS

Consignes de sécurité	4
Conseils d'utilisation	5
Conseils d'entretien	6
Avertissements	7
Montage.....	8

**IMPORTANT, À CONSERVER
POUR CONSULTATION ULTÉRIEURE :
À LIRE ATTENTIVEMENT**

ENGLISH

Safety instructions	4
Directions for use.....	5
Directions for maintenance	6
Warning	7
Assembly	8

**IMPORTANT, RETAIN FOR FUTURE
REFERENCE: PLEASE READ
CAREFULLY**



Destiné à un usage domestique
For domestic use



Attention : risques de blessures
Warning : risk of injuries



Poids maximum supporté : 35 kg
Maximum supported weight: 35 kg / 77lbs

CONSIGNES DE SÉCURITÉ /SAFETY INSTRUCTIONS

FR

- RISQUE D'ÉTOUFFEMENT - Petites pièces. Déconseillé aux enfants de moins de 3 ans.
- NE PAS placer ce produit à proximité d'une fenêtre, car il peut servir de marche-pied à l'enfant et entraîner sa chute par la fenêtre.
- NE PAS placer ce produit à proximité d'une fenêtre où les cordons de stores ou de rideaux pourraient étrangler un enfant.
- Tenir compte des risques engendrés par la présence de foyers ouverts ou autres sources de forte chaleur à proximité immédiate du produit.
- Ne pas utiliser le siège si une pièce est cassée, déchirée ou manquante et d'utiliser uniquement des pièces de rechange approuvées par le fabricant.

EN

- CHOKING HAZARD—Small parts. Not for children under 3 years.
- DO NOT place this product near a window, as it could act as a step for the child and cause it to fall out of the window.
- DO NOT place this product near a window where blind or curtain cords could strangle a child.
- Be aware of the risks posed by open fires or other sources of high heat in the immediate vicinity of the product.
- Do not use the seat if any part is broken, torn or missing and only use spare parts approved by the manufacturer.

CONSEILS D'UTILISATION / DIRECTIONS FOR USE

FR

Pour des raisons de stabilité, et afin de préserver les pas de vis d'un serrage de travers, il est impératif d'assembler manuellement tous les éléments, et de serrer toutes les vis à la main dans un premier temps. Une fois l'assemblage terminé, vous pouvez procéder au serrage de la visserie de manière plus ferme.

EN

To ensure stability and in order to prevent the screw threads from becoming deformed, it is essential to start by assembling and screwing in each piece by hand. Once the assembly is complete, you can proceed to tighten the screws more firmly.

CONSEILS D'ENTRETIEN / DIRECTIONS FOR MAINTENANCE

FR

Bois : Dépoussiérer régulièrement avec un chiffon propre, doux et sec.
Proscrire tout abrasif et produits acides. Ne jamais employer de solvants

EN

Wood: regularly dust with a clean, soft and dry cloth.
Do not use any abrasive or acidic products. Never use cleaning solvents. Professional cleaning only.

AVERTISSEMENTS / WARNING

FR

ATTENTION : Risque de blessure grave ou mortelle en cas de basculement du meuble. Pour éviter que le meuble ne bascule, il faut le fixer au mur de façon permanente à l'aide des pièces incluses pour la fixation. Les vis et chevilles ne sont pas incluses car leur choix dépend du matériau du mur sur lequel est fixé le meuble. Utilisez des vis et chevilles adaptées au matériau du mur.

EN

CAUTION: Risk of mortal or serious injuries in case of the furniture toppling over. To avoid the furniture falling, you must fix it to the wall permanently with the included fixing pieces. Screws and dowels are not included, as the selection of these parts is dependent on the wall material that the furniture will be fixed to. Use the correct screws and dowels for your wall material.

MONTAGE / ASSEMBLY

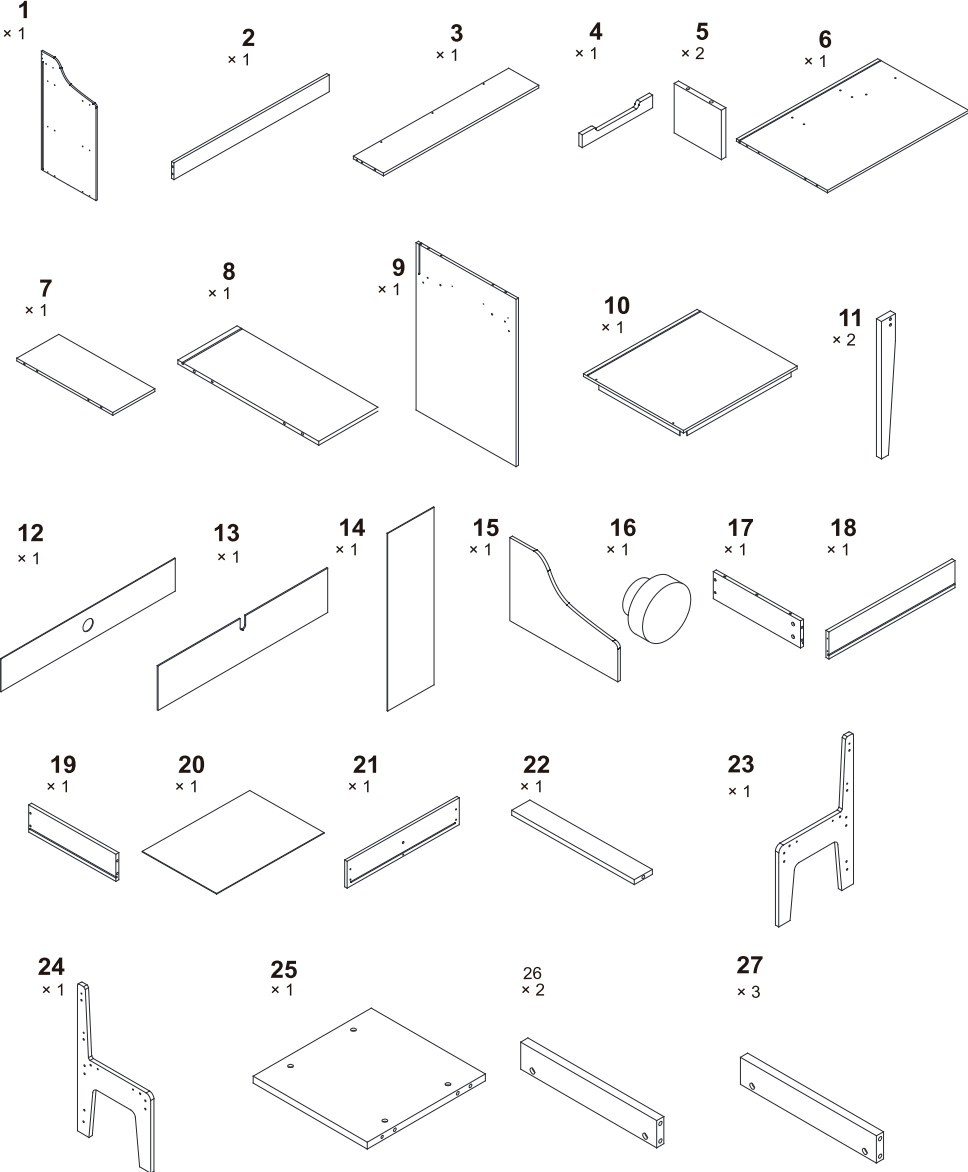

A



M6*38mm
x43
+1(spare)

B



Ø12*10mm
x43
+1(spare)

C



Ø6*25mm
x 38
+1(spare)

D



M4*10mm
x 1

E



M4*30mm
x 15
+1(spare)

F



M3*10mm
x 12
+1(spare)

G

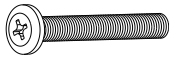

M6*55mm
x 4

H



Ø18*10mm
x 4

I



M4*20mm
x 1

J

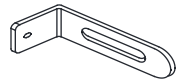

x 1

K



x 12

L



x 1

M



x 4

N



x 4

O



M3*14mm
x 12
+1(spare)

CL

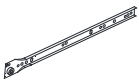

x 1

CR

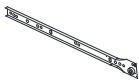

x 1

DL

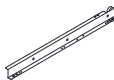

x 1

DR

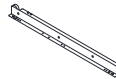

x 1

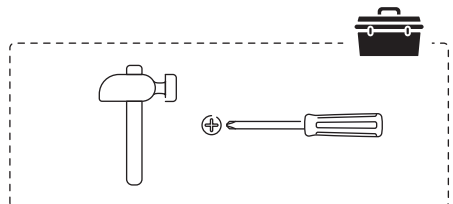

1

E x3

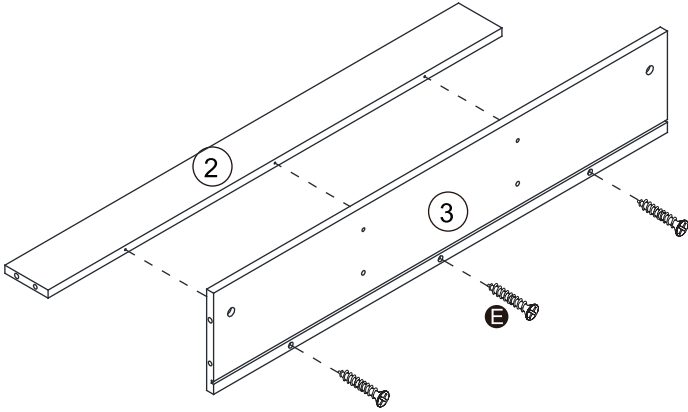

2

A x2

B x2

C x2

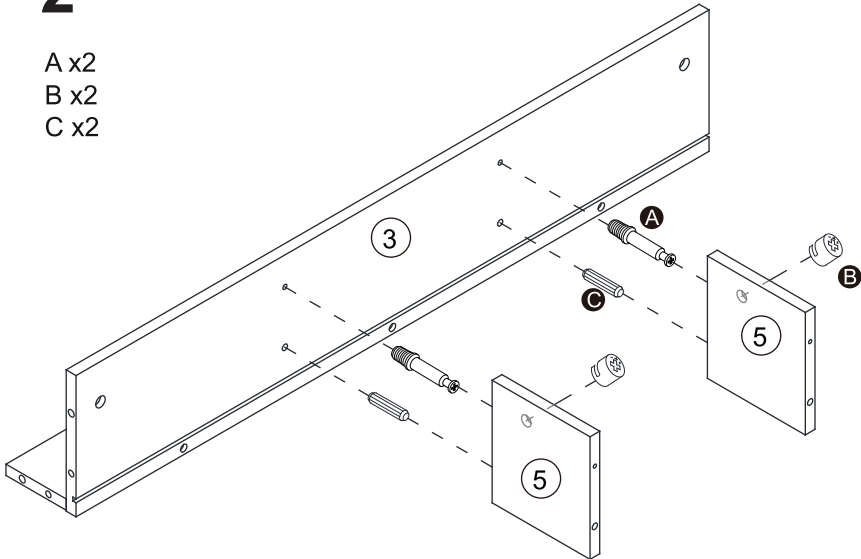

3

E x2

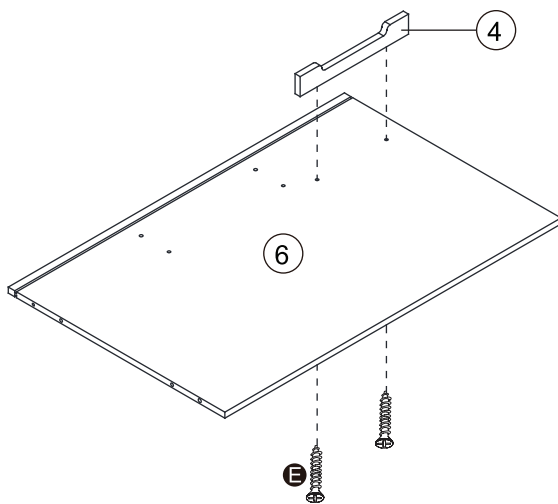

4

C x2

E x2

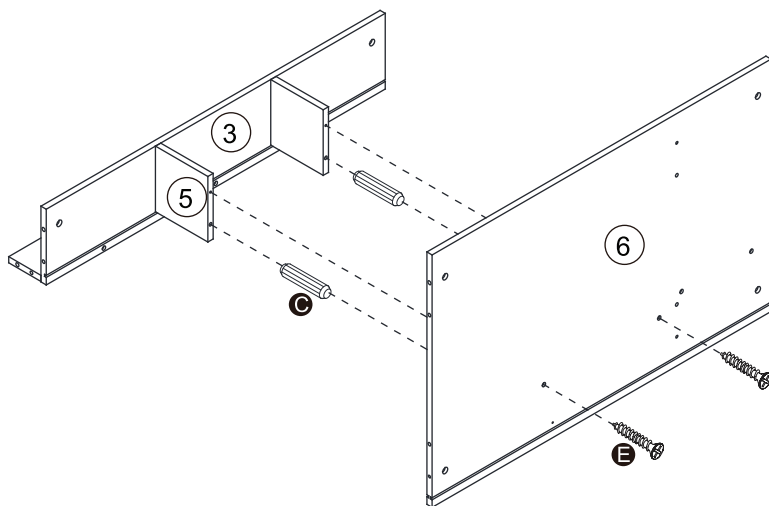

5

A x2
B x2
C x2

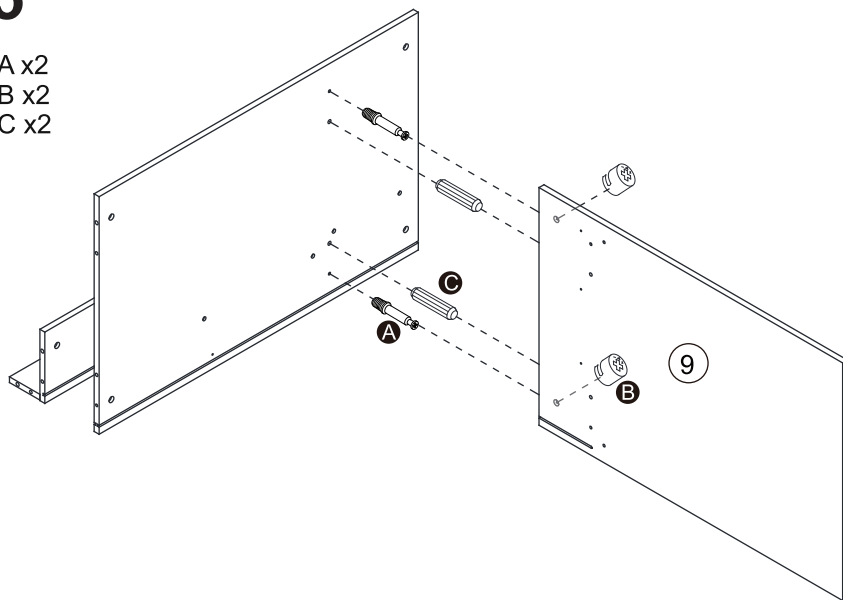

6

F x3
CR x1

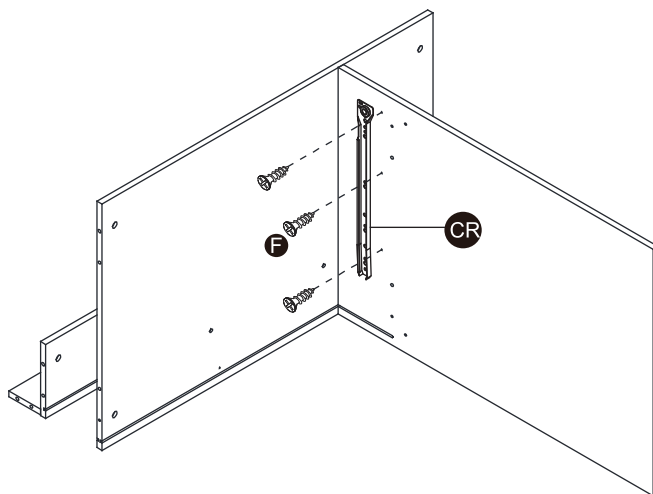

7

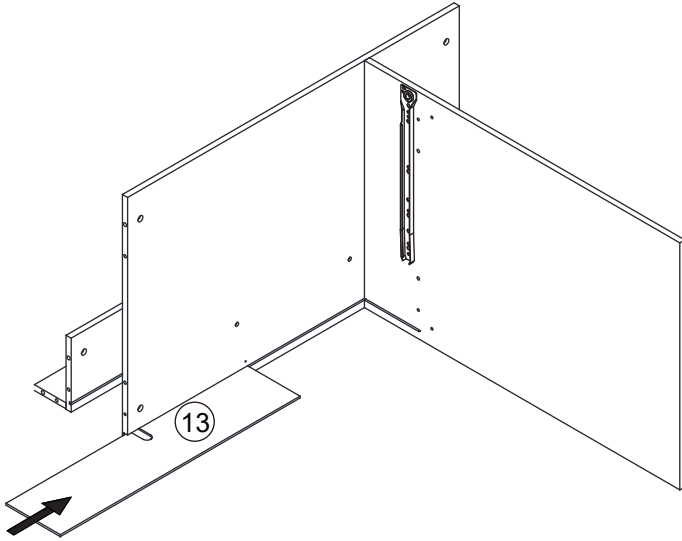

8

D x1
J x1

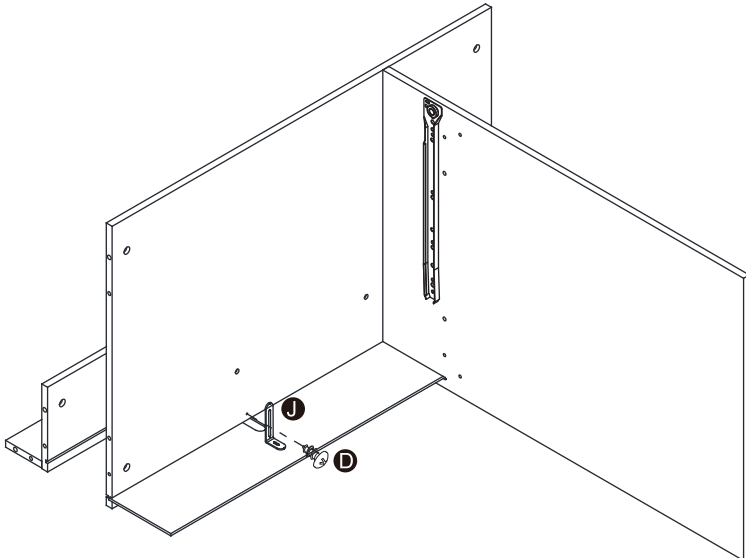

9

A x4

B x4

C x2

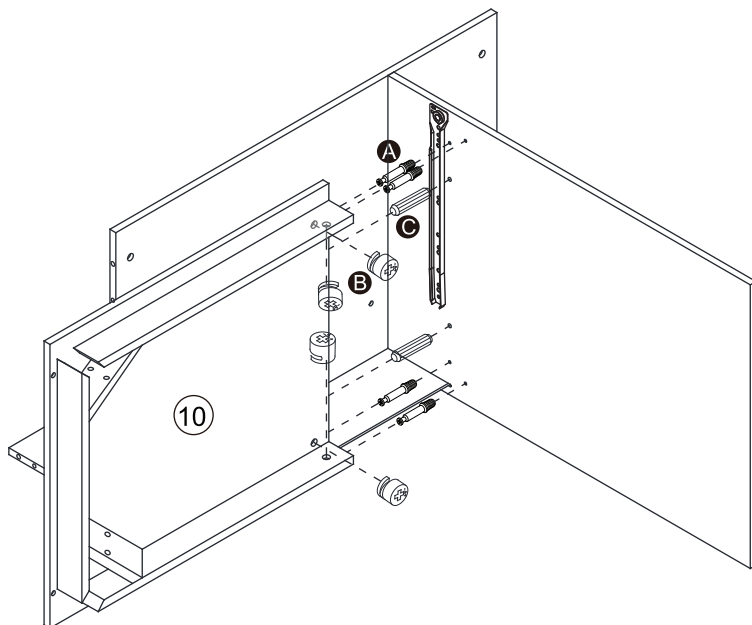

10

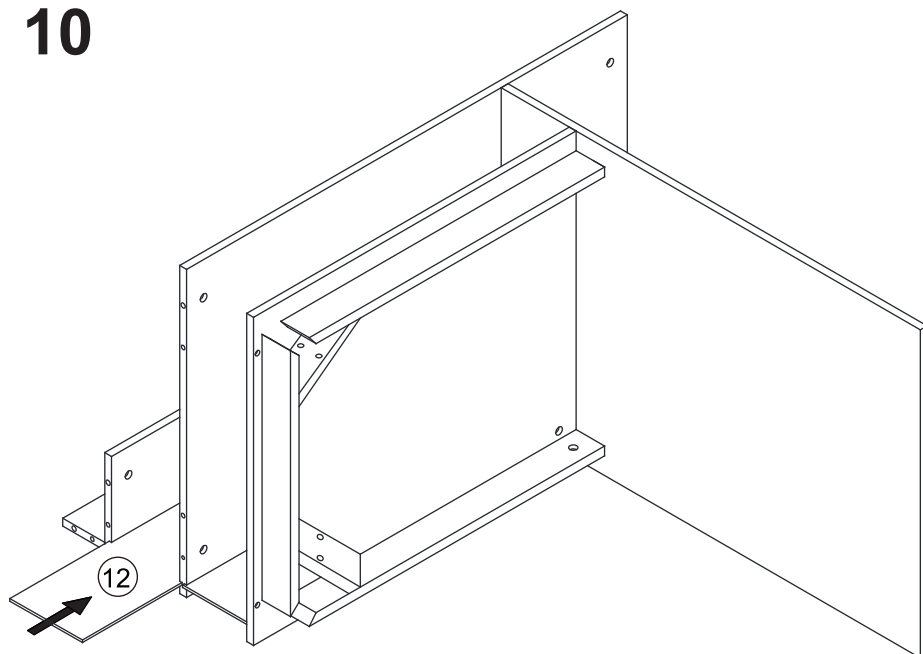

11

A x4
F x3
CL x1

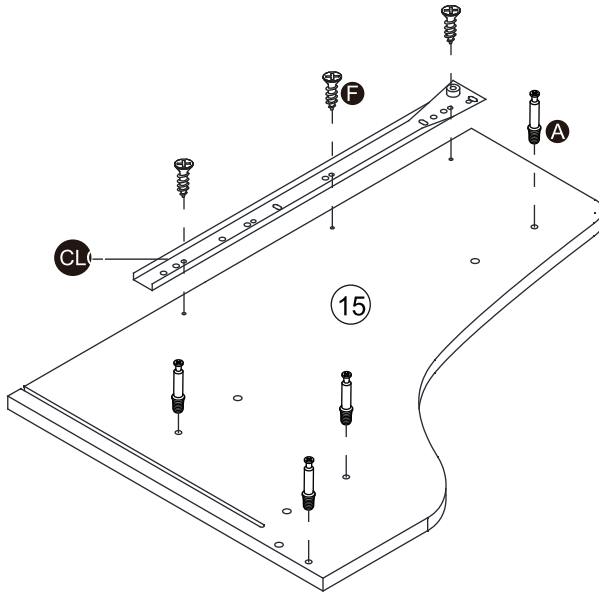

12

B x3
C x4

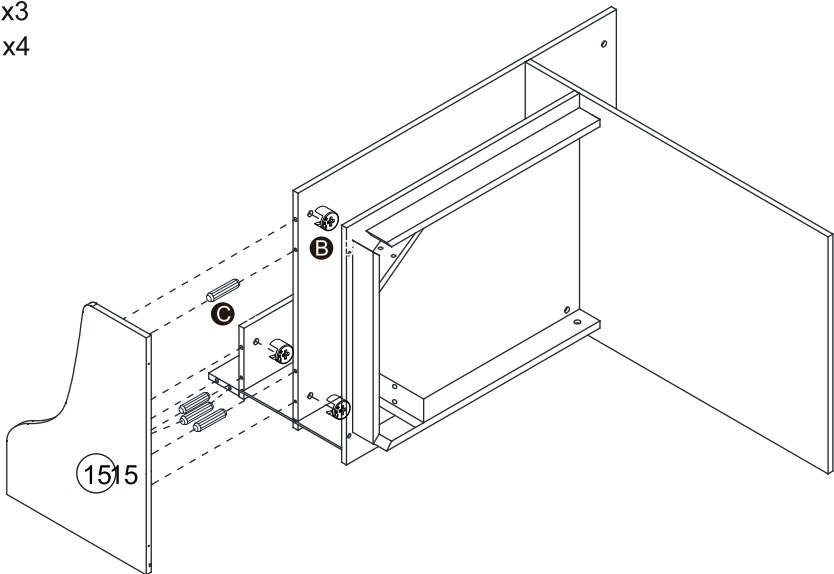

13

E x2

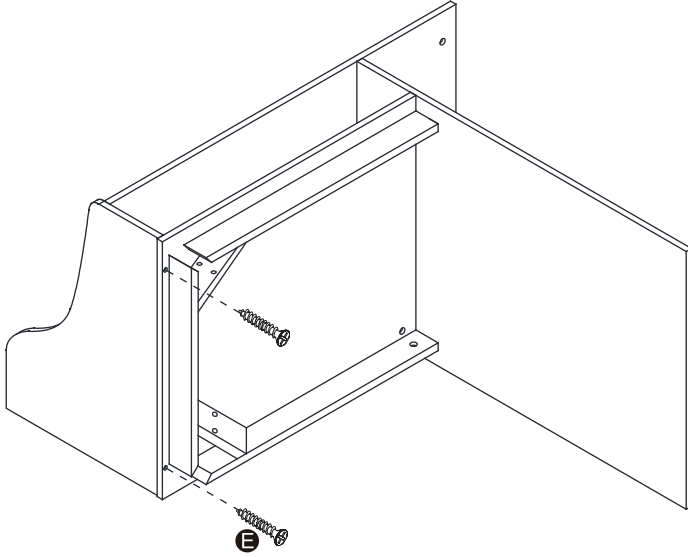

14

A x2

B x2

C x2

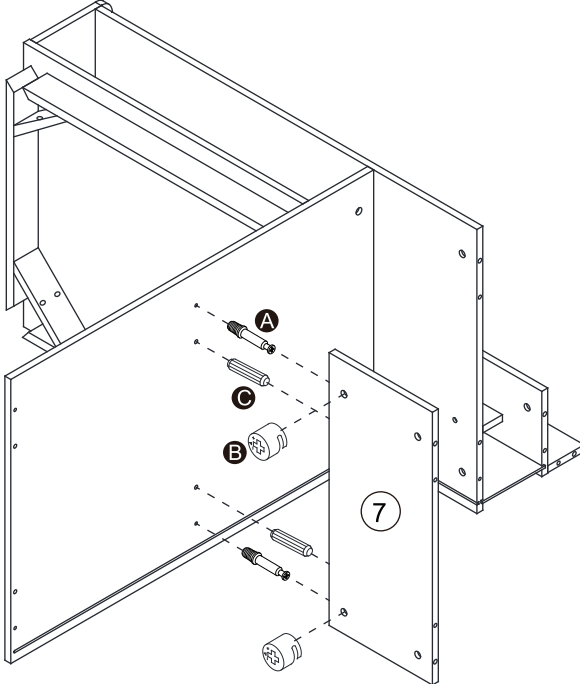

15

A x2

B x2

C x2

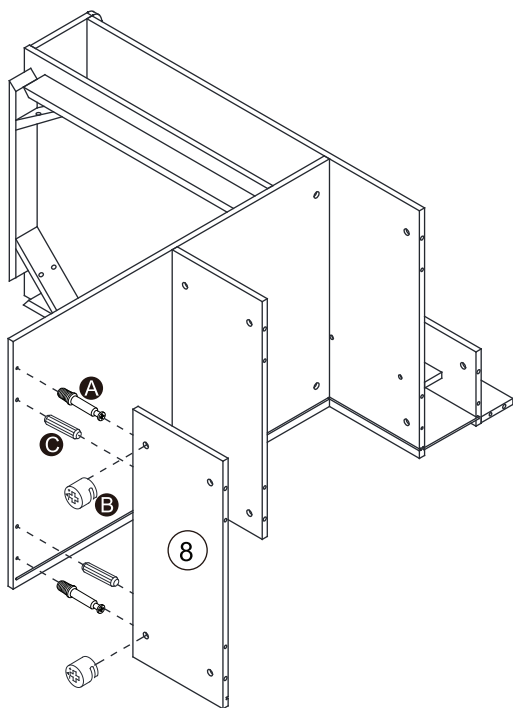

16

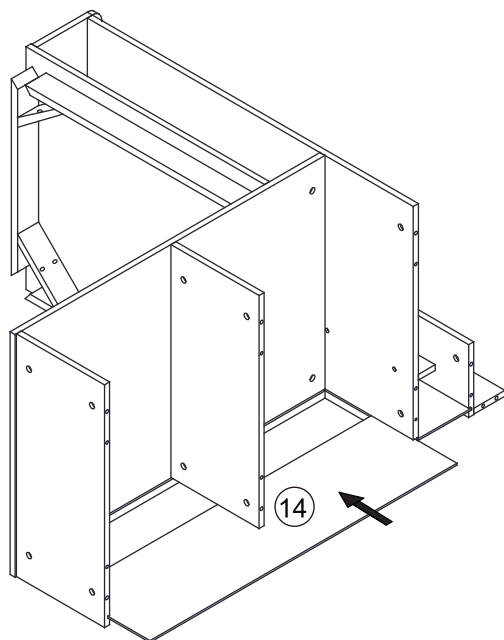

17

A x8

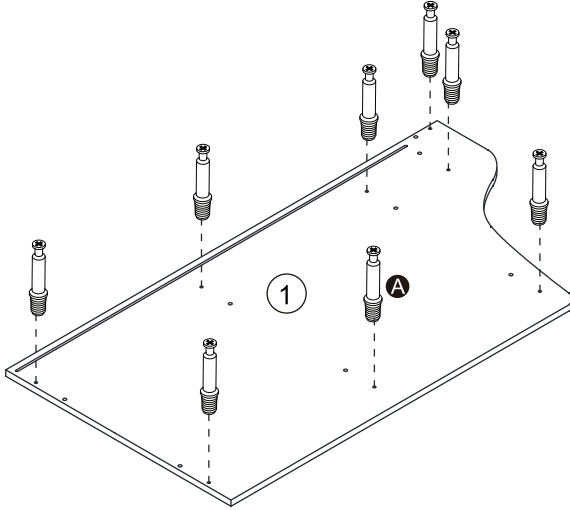

18

B x7
C x8

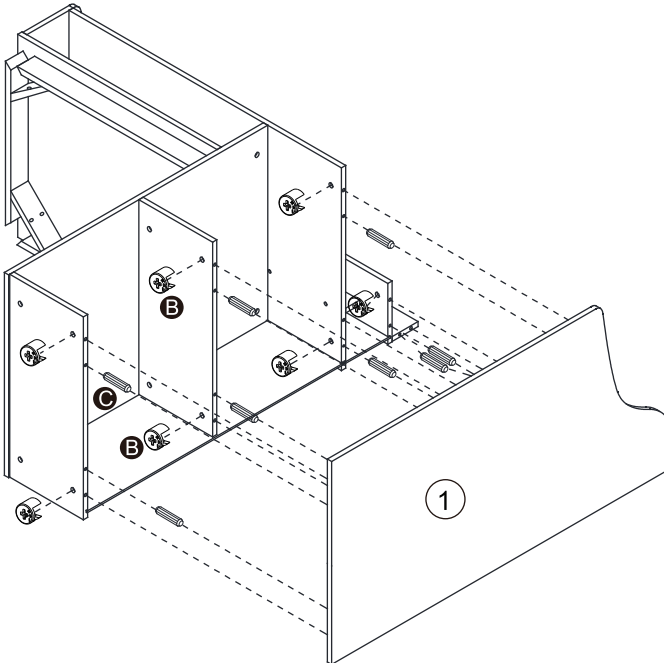

19

G x4
H x4
M x4
N x4

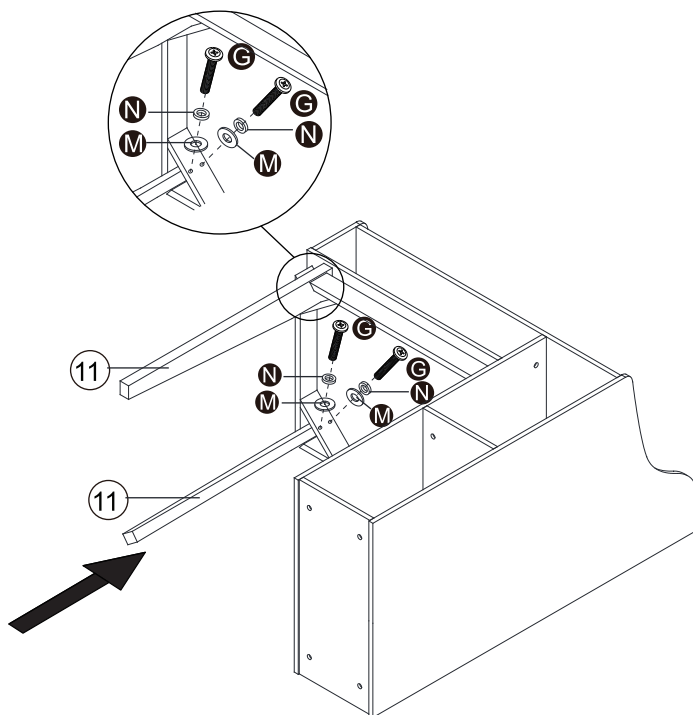
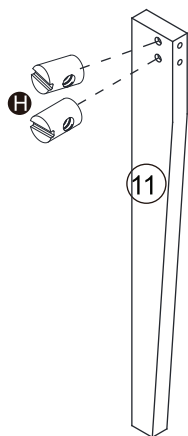

20

B x2

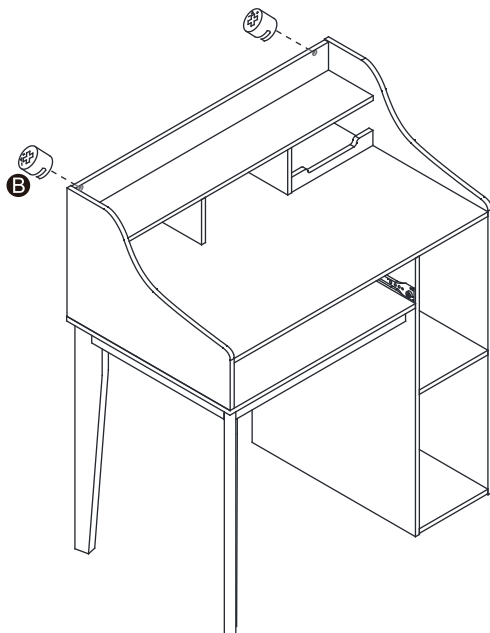

21

E x5

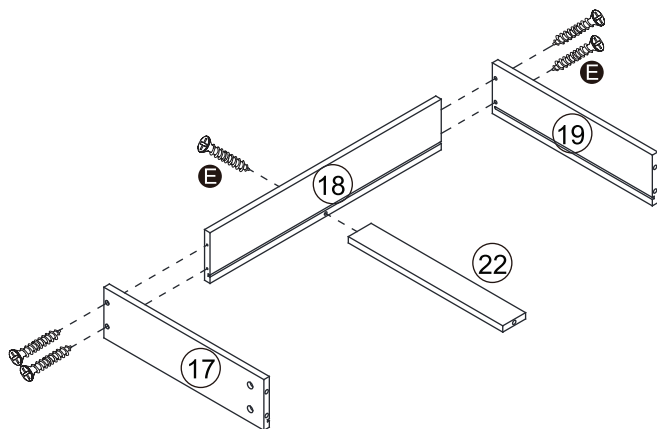

22

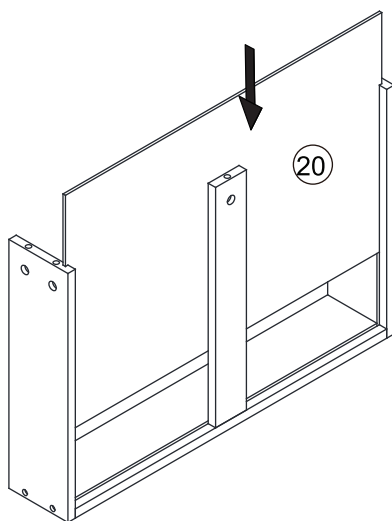

20

23

A x5
B x5

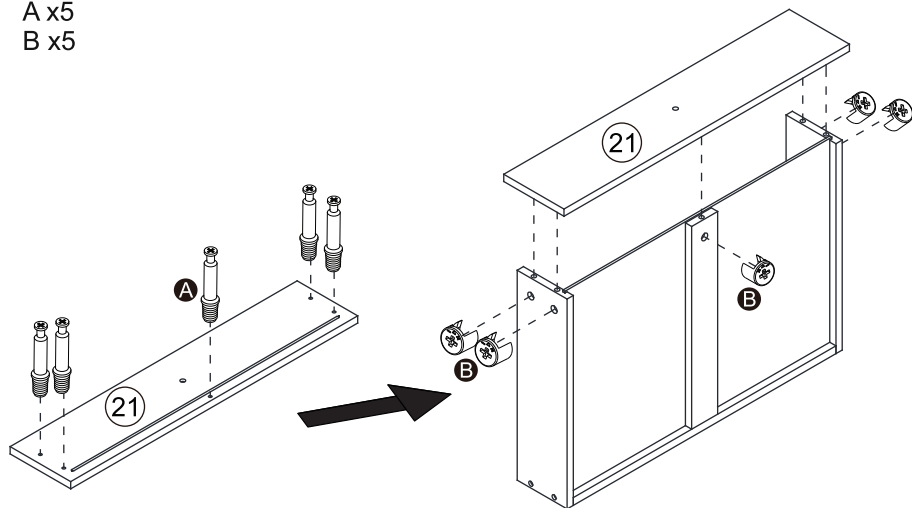

24

I x1

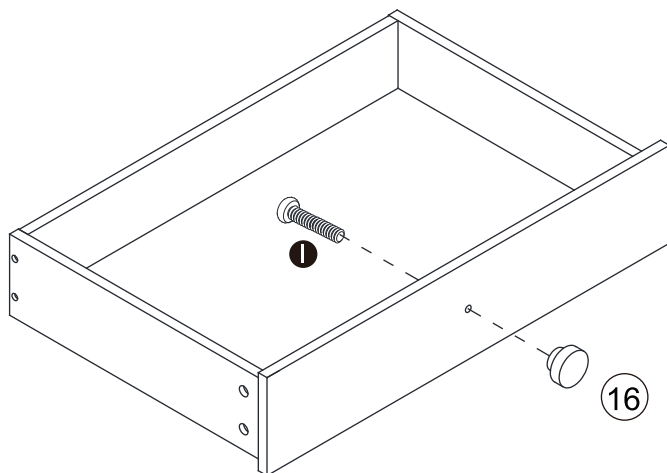

25

F x 6
DR x1
DL x1

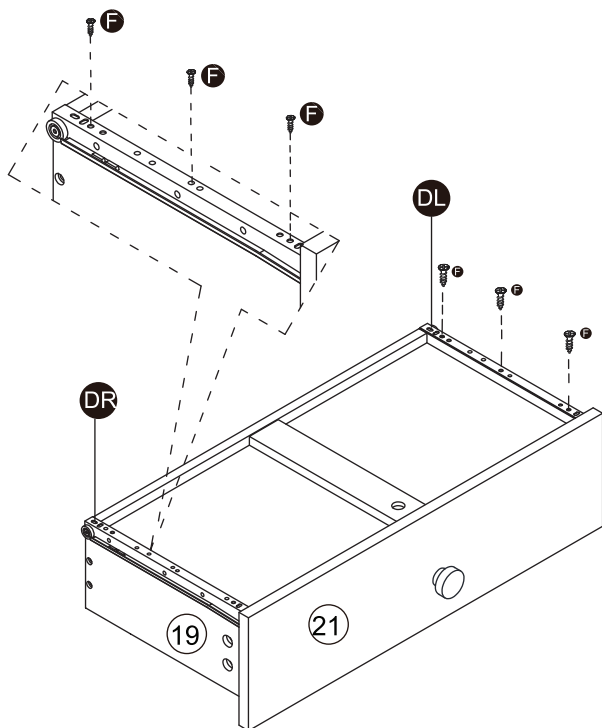

26

E x1
L x1

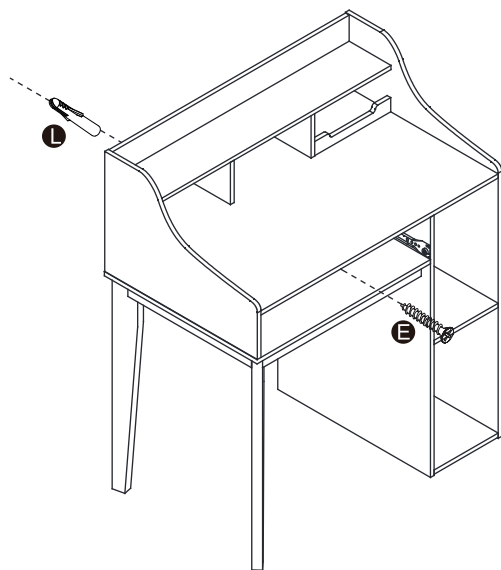

27

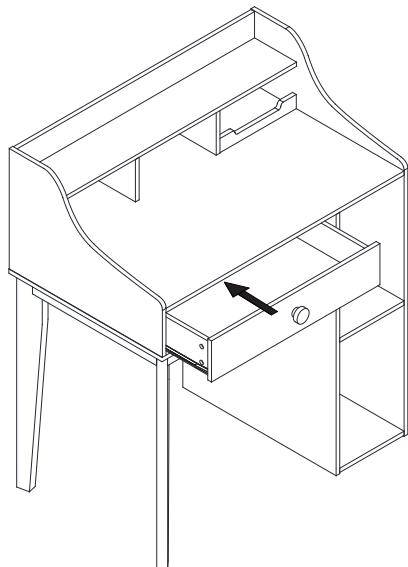

28

O x12
K x12

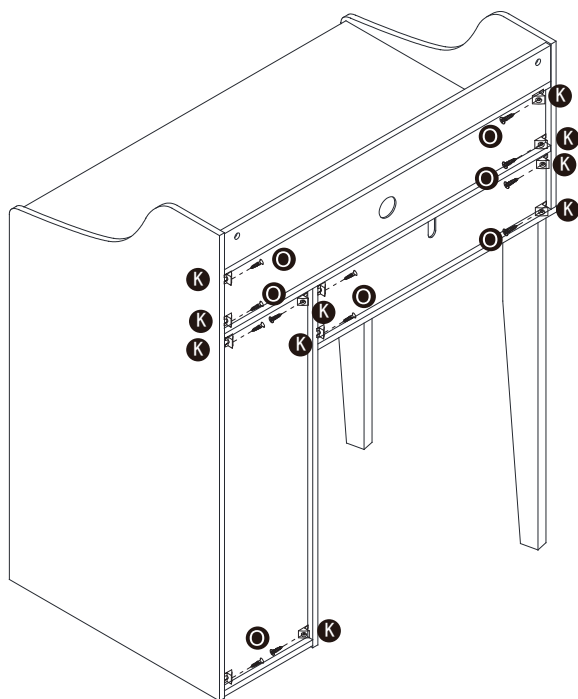

23

29

A x14

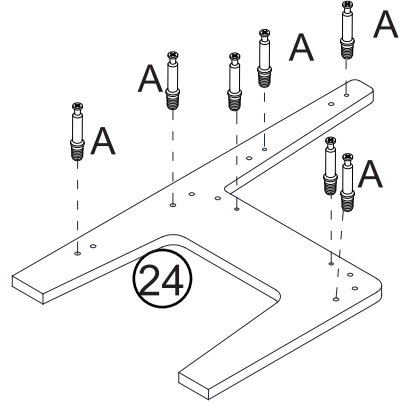
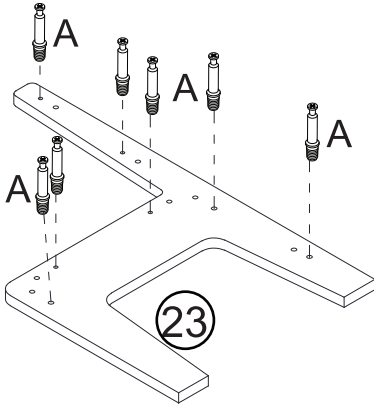

30

B x2

C x2

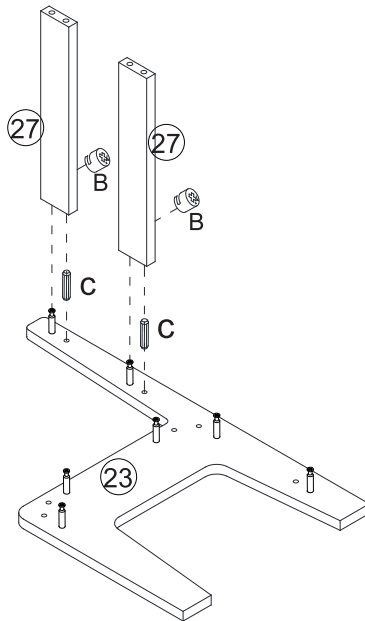

24

31

B x2

C x2

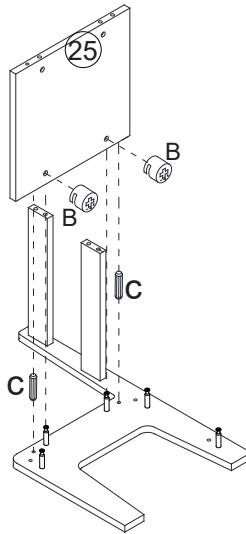

32

B x3

C x3

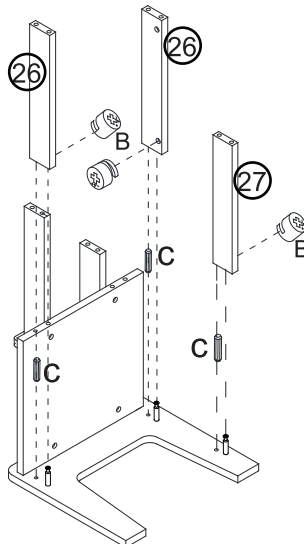

33

C x7

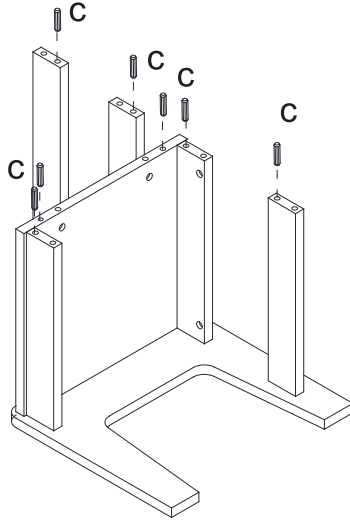

34

B x7

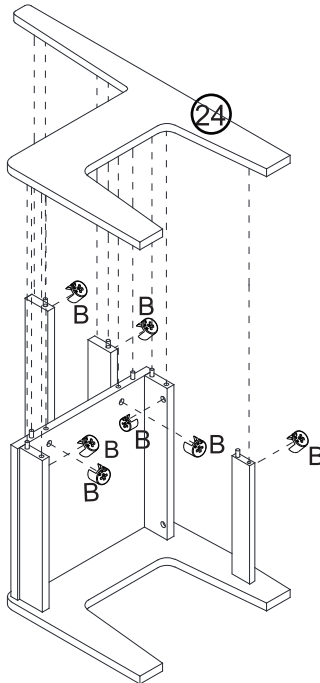

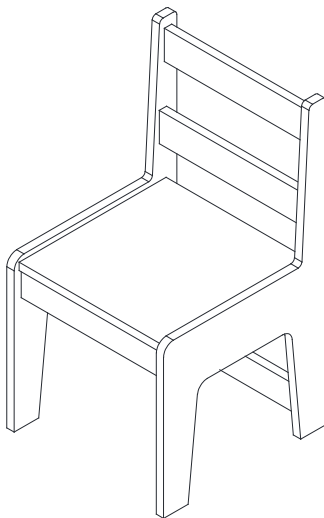

US

If you have any questions, please contact our customer care center.
Our contact details are below:

 001-877-644-9366

 customerservice@aosom.com

Imported by Aosom LLC
27150 SW Kinsman Rd Wilsonville, OR 97070 USA
MADE IN CHINA

CA

If you have any questions, please contact our customer care center.
Our contact details are below:

Si vous avez la moindre question, veuillez contacter notre centre d'assistance à la clientèle.
Nos coordonnées sont les suivantes:

 416-792-6088

 customerservice@aosom.ca

Imported by Aosom Canada Inc.
7270 Woodbine Avenue, Unit 307, Markham, Ontario Canada
L3R 4B9
MADE IN CHINA

Importé par Aosom Canada Inc.
7270 Woodbine Avenue, unité 307, Markham, Ontario Canada
L3R 4B9
FABRIQUÉ EN CHINE

