

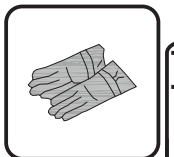

IN240700045V01\_UK\_US\_DE

845-421V01

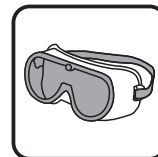
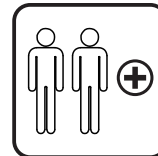
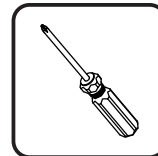
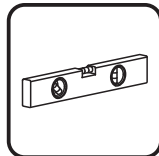
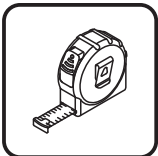
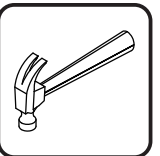
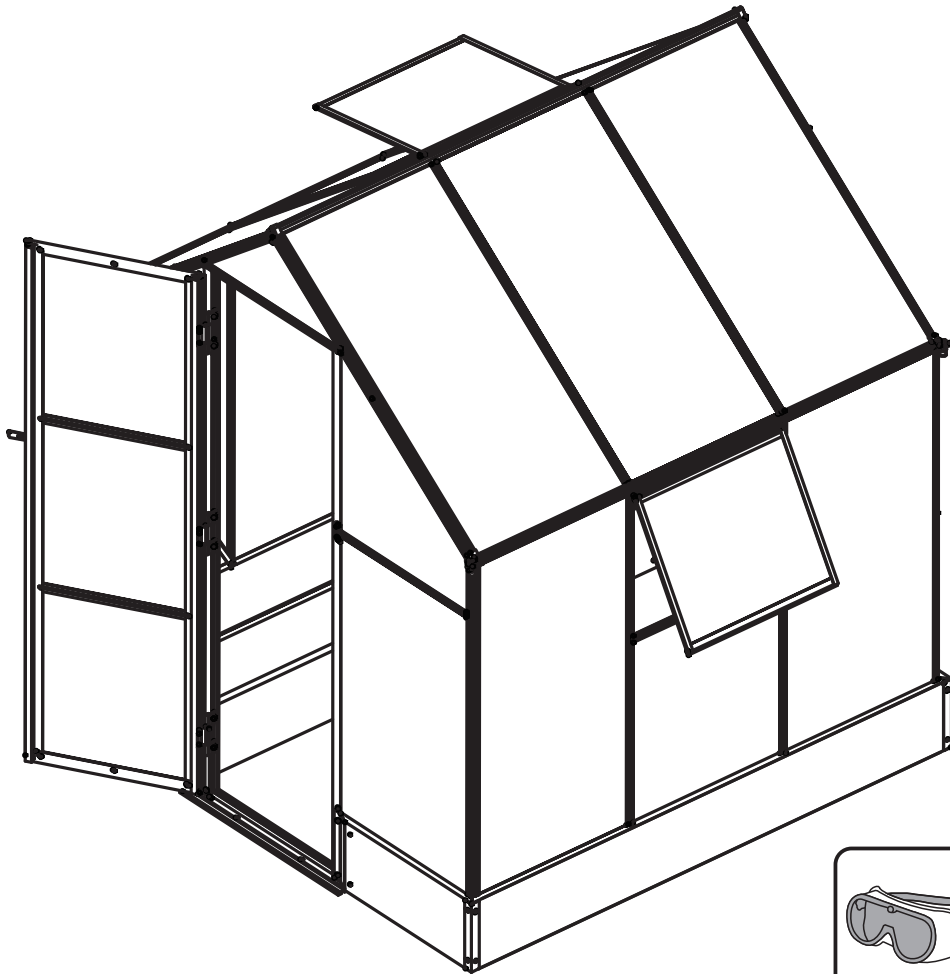

Tools Recommended

**EN\_IMPORTANT, RETAIN FOR FUTURE REFERENCE: READ CAREFULLY.**

**FR\_IMPORTANT: A LIRE ATTENTIVEMENT ET À CONSERVER POUR CONSULTATION ULTÉRIEURE.**

**ES\_IMPORTANTE, LEA Y GUARDE PARA FUTURAS REFERENCIAS.**

**PT\_IMPORTANTE, RETER PARA REFERÊNCIA FUTURA: LEIA ATENTAMENTE.**

**DE\_WICHTIG! SORGFÄLTIG LESEN UND FÜR SPÄTER NACHSCHLAGEN AUFBEWAHREN.**

**IT\_IMPORTANTE! CONSERVARE IL PRESENTE MANUALE PER FUTURO RIFERIMENTO E LEGGERLO ATTENTAMENTE.**

## IMPORTANT

You must read these instructions carefully before you start to assemble this greenhouse. Please ensure that you find all parts in the carton box in the correct type and quantity as mentioned in the list illustrated in every page accordingly. Please carry out the steps in the order set out in these instructions. Do not tighten the steps in the greenhouse until completing on the assembly of the poly carbon ate panels. Keep these instructions in a safe place for future reference.

## SAFETY ADVICE

We strongly recommend the use of work gloves during assembly. Do not attempt to assemble the greenhouse in windy or wet conditions, Do not touch overhead power cables with the aluminum profiles. Always wear shoes and safety goggles when working with extruded aluminum.

Dispose of all plastic bags safety-keep them out of reach of small children.

The greenhouse must be positioned and fixed on a flat level surface.

Do not lean against or push the greenhouse during construction.

Keep children away from the assemble area.

Do not position your greenhouse in an area exposed to excessive wind. Do not attempt to assemble this greenhouse if you are tired ,have taken drugs or alcohol or if you are prone to dizzy spells.

If using a step ladder or power tools ensure that you follow the manufactures safety advice.

Hot items such as recently used grills, blowtorches etc. must not be stores in the greenhouse.

Ensure there are no hidden pipes or cables in the ground before inserting the pegs.

## GENERAL ADVICE

This is a multi-part assembly, Allow at least 140 minutes for assembly. Selecting a site-choose a sunny level position away from overhanging trees.

If you are fixing your greenhouse directly to a solid concrete foundation use the pre drilled holes in the metal base supplied.

The component parts should be checked and laid out close at hand.

Keep all small parts(screws etc)in a bowl so they do not get lost.

Note that the door is hinged on the right hand side and therefore opens to the right.

Keep roof clear of snow and leaves.

Firstly, make sure a good installation location.

Find a flat ground which is 2 times bigger than the Green house before installation.

## OTHER CAUTIONS

1. 2 people required, one is for measuring & taking marks to ensure the installation dimension, the second person is responsible for the installation and the last one do as assistant and assure the safety.
2. High-power electric tools are required, ensure the normal work of them and highly pay attention to electric safety.
3. Be careful when using the kind of blunt tools, like hammer.
4. Wearing long sleeve cotton overalls, gloves and helmet during installation and wear safety glasses when using power tools.
5. No up watching when working height, or the drop screws may hurt your eyes and suffocation causing accidentally when fall into your mouth.
6. No climbing, No standing on the tent to avoid falling down.
7. If injuries immediately, using the first-aid kit to stop bleeding, bind up, In case of emergency, taken immediately to a nearby medical institutions.

### Care & Maintenance:

- 1 Keep the shed clean with soft cloth; When your greenhouse needs cleaning, use a mild detergent solution and risen with cold clean water. Do NOT use acetone, abrasive cleaners or other special detergents to clean the clear panels.
- 2 Keep the door tracks clear of dirt and other stuff that prevent them from sliding easily.
- 3 Clean the snow with necessary tools to make sure it is safe to enter into; Heavy snow may cause collapse, please make sure safety before entering into.
- 4 The shed is not made for living but storing stuff.
- 5 Please add some oil on the top and bottom door sliding channel to make door slides smoothly.

## WICHTIG

Sie müssen diese Anleitung sorgfältig lesen, bevor Sie mit dem Zusammenbau dieses Gewächshauses beginnen. Bitte stellen Sie sicher, dass Sie alle Teile im Karton in der richtigen Art und Menge vorfinden, wie in der auf jeder Seite entsprechend abgebildeten Liste angegeben. Bitte führen Sie die Schritte in der in dieser Anleitung angegebenen Reihenfolge aus. Bitte ziehen Sie die Treppe im Gewächshaus erst dann fest, wenn die Montage der Polycarbonatplatten abgeschlossen ist. Bewahren Sie diese Anleitung zum späteren Nachschlagen an einem sicheren Ort auf.

## SICHERHEITSHINWEISE

Wir empfehlen dringend die Verwendung von Arbeitshandschuhen während der Montage.

Versuchen Sie nicht, das Gewächshaus bei Wind oder Nässe zu montieren.

Berühren Sie keine Freileitungskabel mit den Aluminiumprofilen.

Tragen Sie immer Schuhe und Schutzbrille, wenn Sie mit stranggepresstem Aluminium arbeiten.

Entsorgen Sie alle Plastiktüten sicherheitshalber und bewahren Sie sie außerhalb der Reichweite von kleinen Kindern auf.

Das Gewächshaus muss auf einer ebenen Fläche aufgestellt und befestigt werden.

Lehnen Sie sich während des Baus nicht gegen das Gewächshaus und schieben Sie es nicht.

Halten Sie Kinder vom Aufbaubereich fern.

Stellen Sie Ihr Gewächshaus nicht in einem Bereich auf, der übermäßigem Wind ausgesetzt ist.

Versuchen Sie nicht, das Gewächshaus zusammenzubauen, wenn Sie müde sind, Drogen oder Alkohol genommen haben oder zu Schwindelanfällen neigen.

Wenn Sie eine Trittleiter oder Elektrowerkzeuge verwenden, stellen Sie sicher, dass Sie die Sicherheitshinweise des Herstellers befolgen.

Heiße Gegenstände wie kürzlich benutzte Grillgeräte, Lötlampen usw. dürfen nicht im Gewächshaus aufbewahrt werden.

Stellen Sie sicher, dass sich keine versteckten Rohre oder Kabel im Boden befinden, bevor Sie die Heringe einsetzen.

## GENERELLE HINWEISE

Es handelt sich um eine mehrteilige Montage. Für die Montage sind mindestens 140 Minuten einzuplanen.

Wählen Sie einen Standort: Wählen Sie einen sonnigen, ebenen Standort, der von überhängenden Bäumen entfernt ist.

Wenn Sie Ihr Gewächshaus direkt auf einem soliden Betonfundament befestigen, verwenden Sie die vorgebohrten Löcher in der mitgelieferten Metallbasis.

Die Einzelteile sollten in unmittelbarer Nähe überprüft und ausgelegt werden.

Bewahren Sie alle Kleinteile (Schrauben usw.) in einer Schale auf, damit sie nicht verloren gehen.

Beachten Sie, dass die Tür rechts angeschlagen ist und sich daher nach rechts öffnet.

Halten Sie das Dach frei von Schnee und Laub.

Achten Sie zunächst auf einen guten Installationsort mit einem ebenen Boden. Der 2 Mal größer ist als das Gewächshaus vor der Installation.

## ANDERE HINWEISE



1. 2 Personen sind für die Installation erforderlich. Die zweite Person ist für die Installation verantwortlich und die letzte Person fungiert als Assistent und gewährleistet die Sicherheit.
2. Für die Installation sind elektrische Hochleistungswerkzeuge erforderlich. Bitte stellen Sie deren normale Arbeit sicher und achten Sie in hohem Maße auf die elektrische Sicherheit.
3. Seien Sie vorsichtig, wenn Sie stumpfe Werkzeuge wie z.B. einen Hammer verwenden.
4. Tragen Sie während der Installation langärmelige Baumwolloveralls, Handschuhe und einen Helm und tragen Sie eine Schutzbrille, wenn Sie Elektrowerkzeuge verwenden.
5. Bei der Arbeit in Arbeitshöhe darf man nicht nach oben schauen, sonst können die Fallschrauben Ihre Augen verletzen und Sie ersticken, wenn Sie versehentlich in den Mund fallen.
6. Kein Klettern, kein Stehen auf dem Zelt, um ein Herunterfallen zu vermeiden.
7. Bei Verletzungen benutzen Sie bitte einen Erste-Hilfe-Kasten, um die Blutung zu stoppen und zu binden. Bei einem Notfall suchen Sie bitte sofort ein Krankenhaus auf.



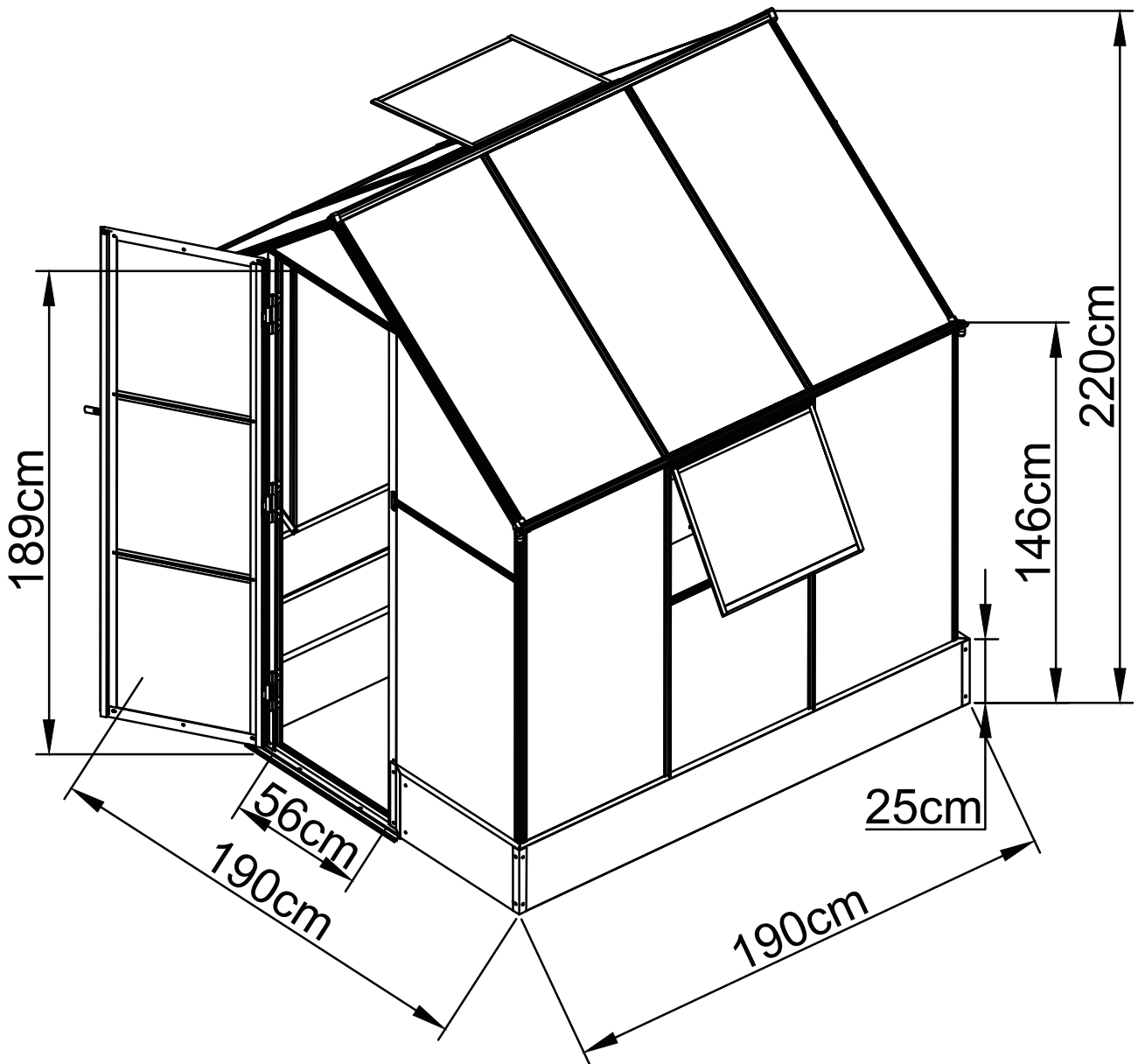

### **Pflege und Wartung:**

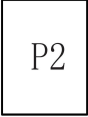
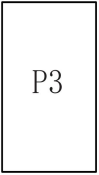
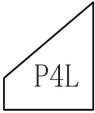
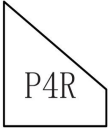
- 1 Halten Sie den Schuppen mit einem weichen Tuch sauber; Wenn Ihr Gewächshaus gereinigt werden muss, verwenden Sie eine milde Reinigungsmittellösung und spülen Sie es mit kaltem, sauberem Wasser ab. Verwenden Sie KEIN Aceton, Scheuermittel oder andere spezielle Reinigungsmittel, um die durchsichtigen Platten zu reinigen.
- 2 Halten Sie die Türschienen von Schmutz und anderen Gegenständen fern, damit sie nicht leicht verrutschen können.
- 3 Reinigen Sie den Schnee mit den notwendigen Werkzeugen, um sicherzugehen, dass Sie sicher betreten können; Starker Schneefall kann zum Einsturz führen, bitte gewährleisten Sie die Sicherheit vor dem Betreten .
- 4 Der Schuppen ist nicht zum Wohnen gemacht, sondern zum Aufbewahren von Sachen.
- 5 Bitte geben Sie etwas Öl auf den oberen und unteren Schiebekanal der Tür, damit die Tür reibungslos gleitet.

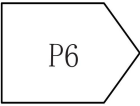

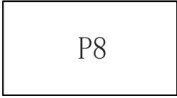









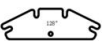









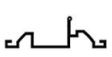





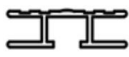













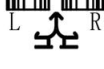









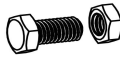
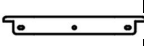

**845-421V01**  
**Carton: 1/2**

PART	NO.	Qty.
	<b>P2</b>	2
	<b>P3</b>	5
	<b>P4L</b>	2
	<b>P4R</b>	2
	<b>P5</b>	1
	<b>P6</b>	1



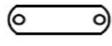







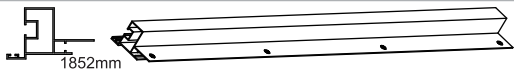
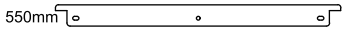

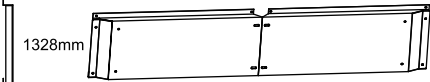

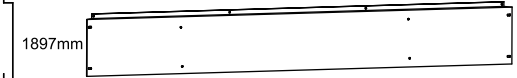
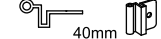

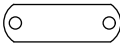





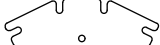

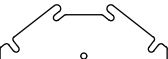
PART	NO.	Qty.
	<b>P7</b>	1
	<b>P8</b>	5
	<b>P9</b>	5
	<b>P10</b>	1
	<b>PD1</b>	3

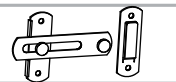

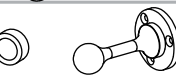







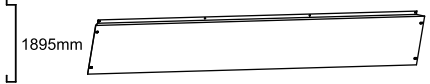



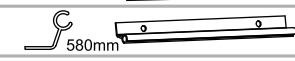
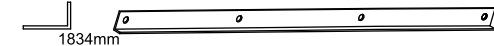



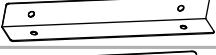

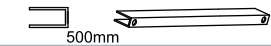
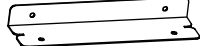



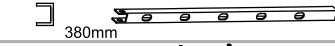

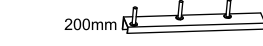
# 845-421V01

Carton: 2/2

PART	NO.	Qty.	PART	NO.	Qty.	PART	NO.	Qty.
	<b>D1</b>	2		<b>B5</b>	4		<b>PB1</b>	2
	<b>D2</b>	4		<b>B6</b>	2		<b>B3</b>	2
	<b>5</b>	3		<b>L3</b>	1		<b>3B</b>	4
	<b>6</b>	6		<b>L3-1</b>	1		<b>PB03</b>	4
	<b>D7</b>	1		<b>L2</b>	1		<b>S2</b>	11
	<b>D5</b>	1		<b>L5</b>	3		<b>S5</b>	2
	<b>9L</b>	1		<b>15</b>	7		<b>S6L</b>	2
	<b>9R</b>	1		<b>19</b>	4		<b>S6R</b>	2
	<b>7</b>	4		<b>20</b>	4		<b>S8</b>	2
	<b>16</b>	4		<b>26</b>	2		<b>S9</b>	2
	<b>10L</b>	1		<b>27L</b>	2		<b>F1</b>	6
	<b>10R</b>	1		<b>W1</b>	2		<b>F2</b>	8
	<b>14</b>	1		<b>W2</b>	4		<b>F3</b>	48
	<b>22</b>	4		<b>W3</b>	2		<b>F4</b>	146
	<b>23</b>	4		<b>W4</b>	2		<b>F6</b>	6
	<b>D3</b>	2		<b>B7</b>	2		<b>F8</b>	2
	<b>NBP1</b>	1		<b>8</b>	2		<b>F9</b>	2
	<b>NBP2</b>	1		<b>25</b>	2		<b>F04</b>	150
	<b>C2</b>	8		<b>17</b>	1		<b>F03</b>	80
	<b>B4</b>	4		<b>NBP5</b>	2			



NO.	Qty.		NO.	Qty.		NO.	Qty.	
D1	2		D3	2				
D2	4		NBP1	1				
5	3		NBP2	1				
6	6							
D7	1		NO.	Qty.		NO.	Qty.	
D5	1		C2	8		F1	6	
9L	1		B4	4		F6	6	
9R	1		B5	4				
7	4		B6	2				
16	4		L3	1				
10L	1		L3-1	1				
10R	1		L2	1				
14	1		L5	3				
22	4							
23	4							

NO.	Qty.		NO.	Qty.		NO.	Qty.	
15	7		NBP5	2				
19	4		PB1	2				
20	4							
26	2		NO.	Qty.		NO.	Qty.	
27L	2		B3	2		F2	8	
W1	2		3B	4		F3	48	
W2	4		PB03	4		F4	146	
W3	2		S2	11		F8	2	
W4	2		S5	2		F9	2	
B7	2		S6L	2		F04	n	M5 
8	2		S6R	2		S8	2	F03 n 
25	2		S8	2		S9	2	
17	1							

**EN\_ Summary of polycarbonate panel**

**DE\_ Zusammenfassung der Polycarbonat-Platte**

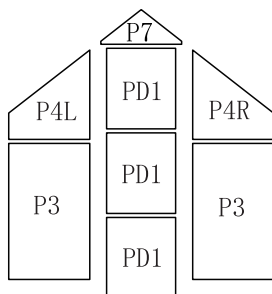
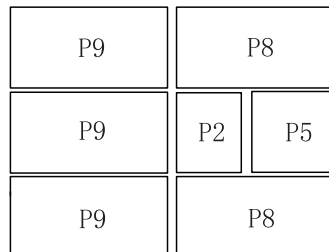
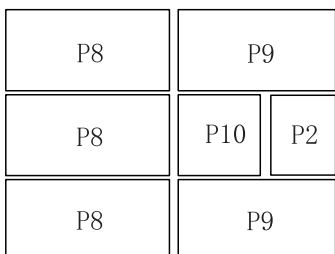
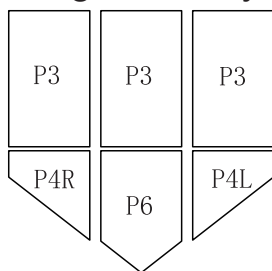

**EN\_ Towards the white film side to the sun as it is UV-protected.**

**DE\_ In Richtung der weißen Folienseite zur Sonne, da diese UV-geschützt ist.**

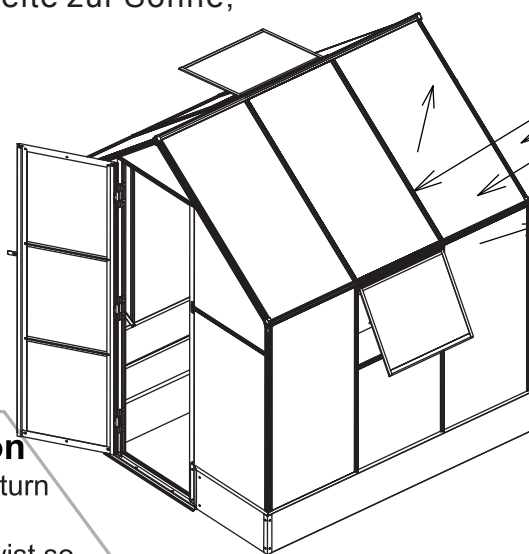
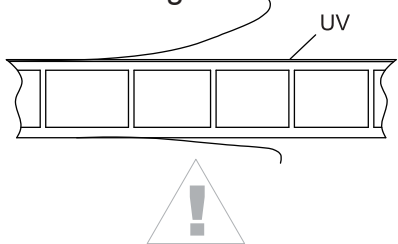

**EN\_ "hexagonal screw" installation**

Place the "hexagonal screw" into the groove, turn clockwise until it stops turning.  
Adjust the "hexagonal screw" by hand and twist so threads fix it in place.  
Place other parts on "hexagonal screw" and assemble nut .

**DE\_ "Montage mit "Sechskantschraube"**  
Setzen Sie die "Sechskantschraube" in die Nut ein und drehen Sie sie im Uhrzeigersinn bis zum Anschlag.  
Stellen Sie die "Sechskantschraube" von Hand ein und drehen Sie sie so, dass sie durch Gewinde fixiert wird.  
Setzen Sie die anderen Teile auf die Sechskantschraube und montieren Sie die Mutter.

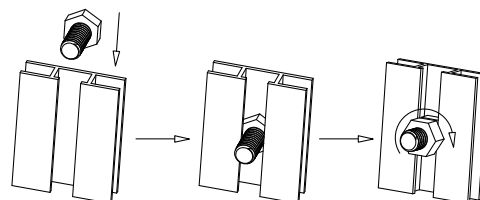

# EN\_DOOR FR\_TÜR

01

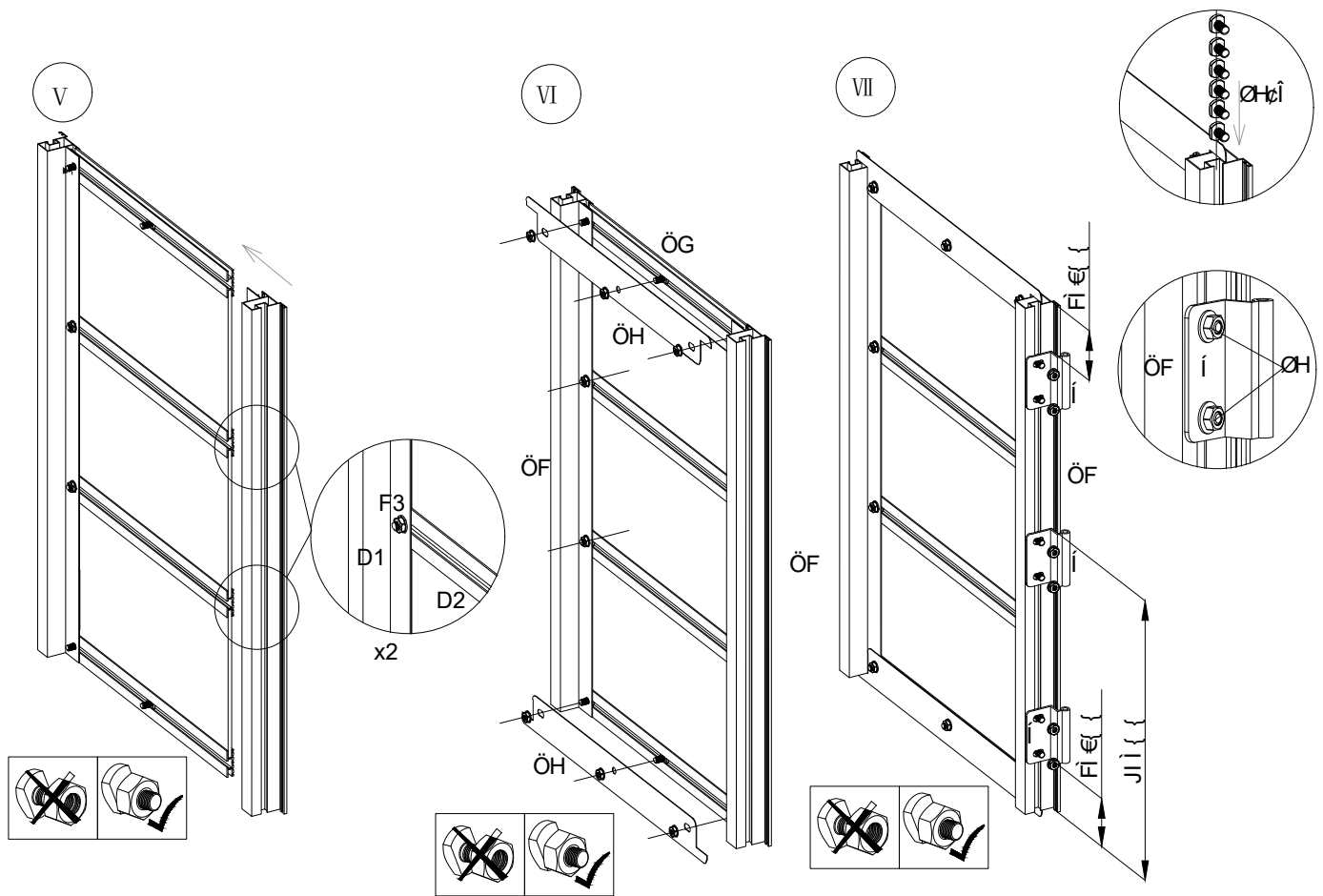
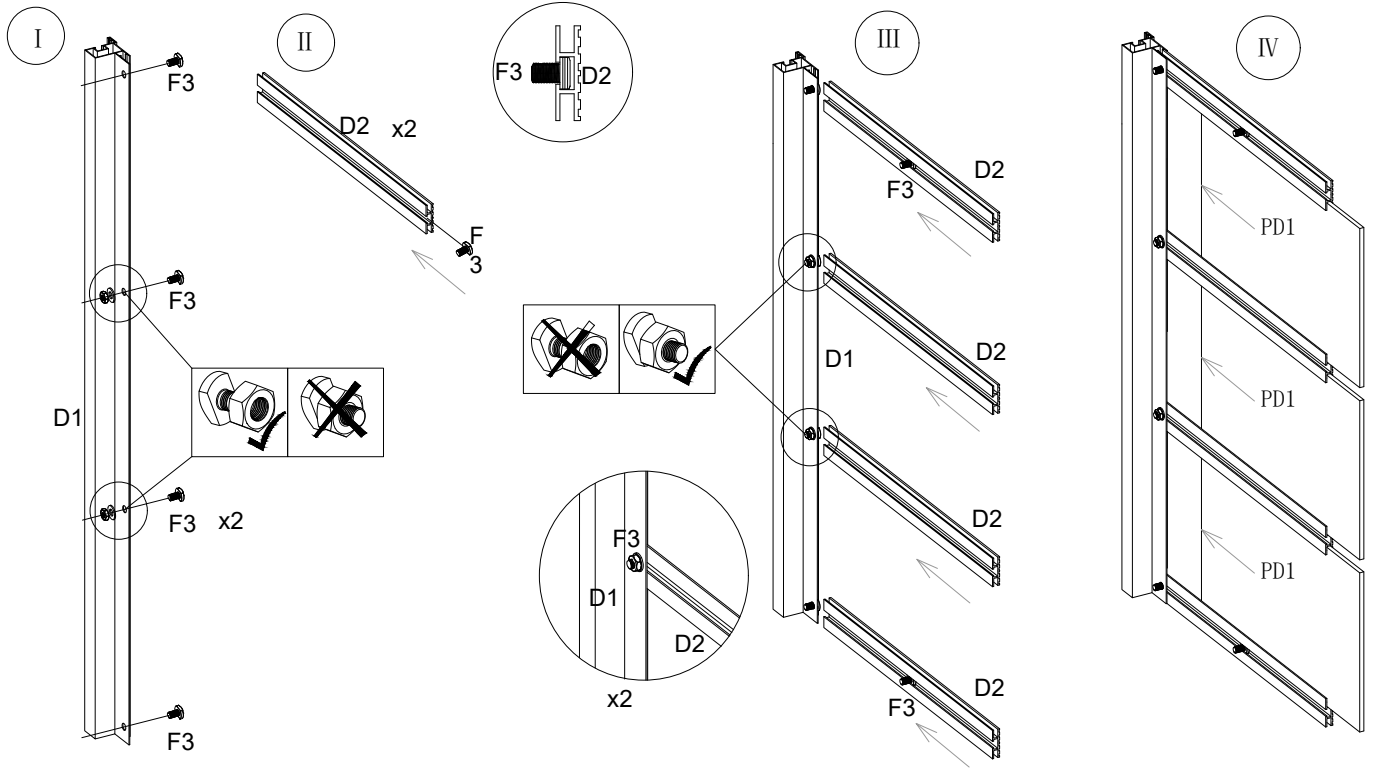
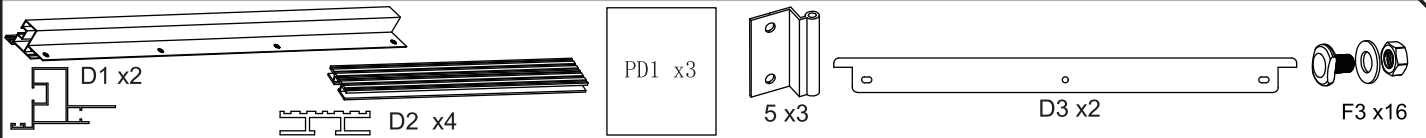

# EN\_WINDOW DE\_FENSTER

02

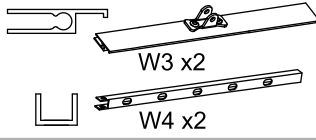
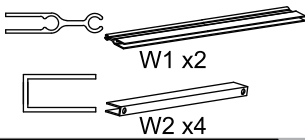

## FENSTER\*2

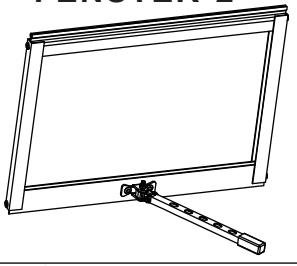

EN\_Note toward the UV surface to the Sun.

Note the direction of part No.3

DE\_Hinweis in Richtung der UV-Oberfläche zur Sonne. Beachten Sie die Richtung von Teil Nr.3

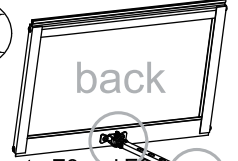

EN\_Note the direction of parts F8 and F9  
DE\_Beachten Sie die Richtung der Teile F8 und F9



EN\_F2 will be easy to install by using lubricants  
DE\_F2 wird durch die Verwendung von Schmiermitteln leicht zu installieren sein

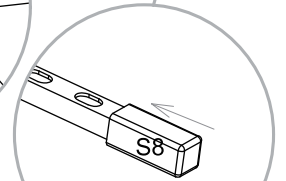
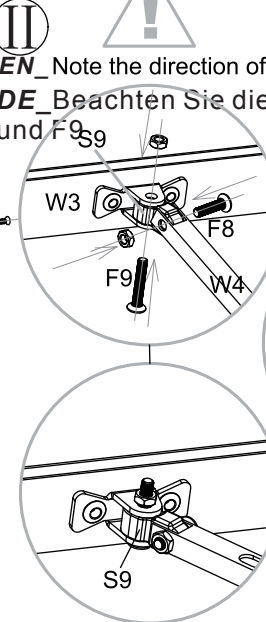
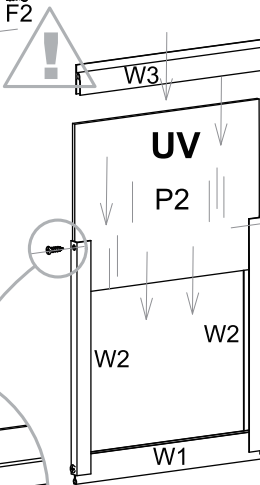
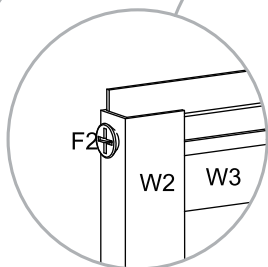
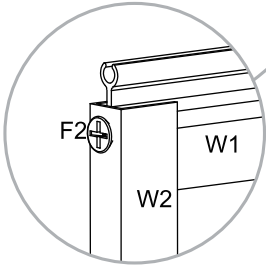

03

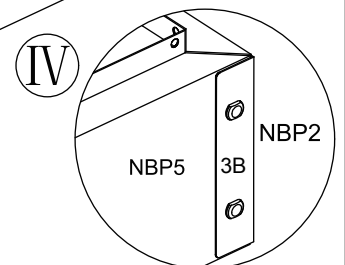
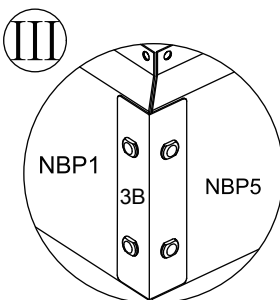
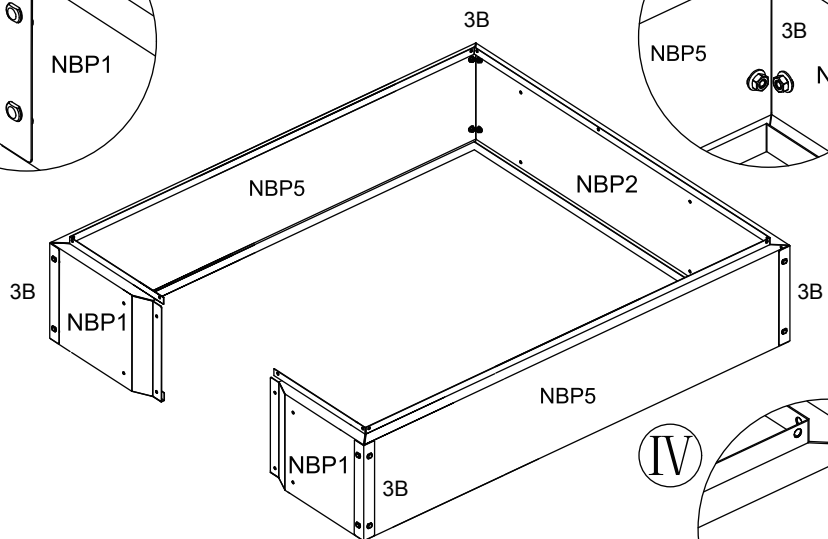
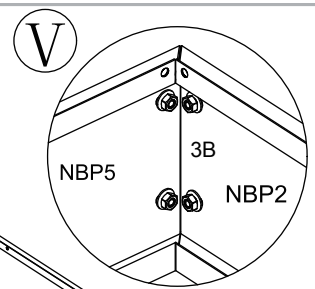
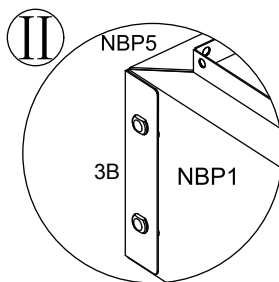
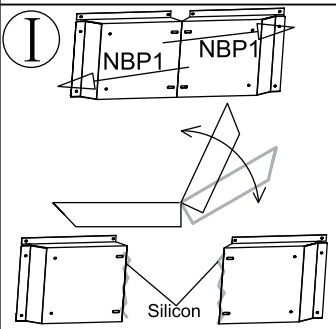
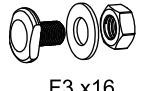
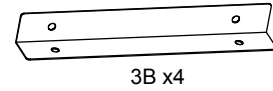
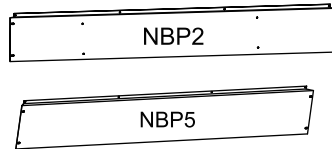
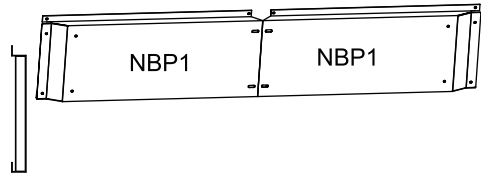

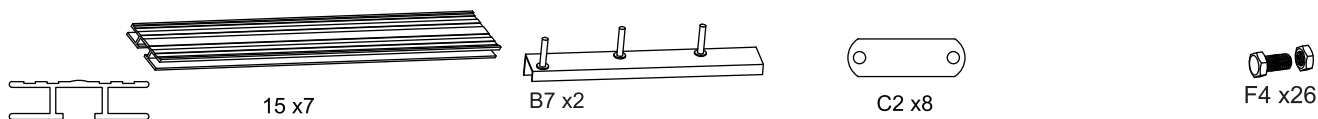

**EN\_** Use hands to tighten the screws F4 cannot slide.  
**DE\_** Ziehen Sie die Schrauben F4 mit den Händen an, die nicht gleiten können.

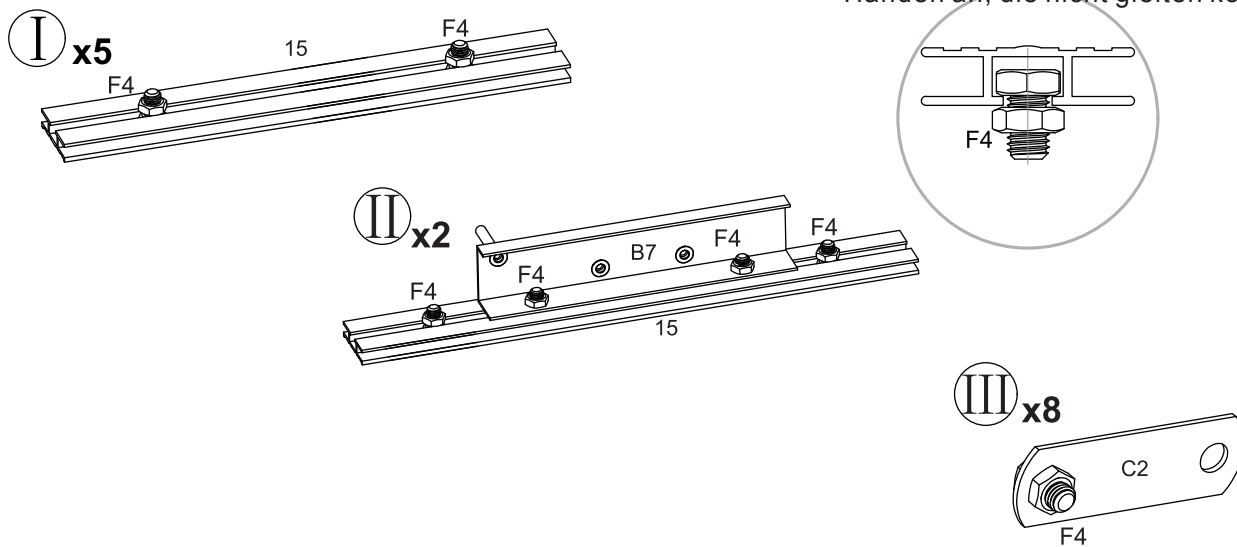

**EN\_** BACK WALL  
**DE\_** ZURÜCKWAND

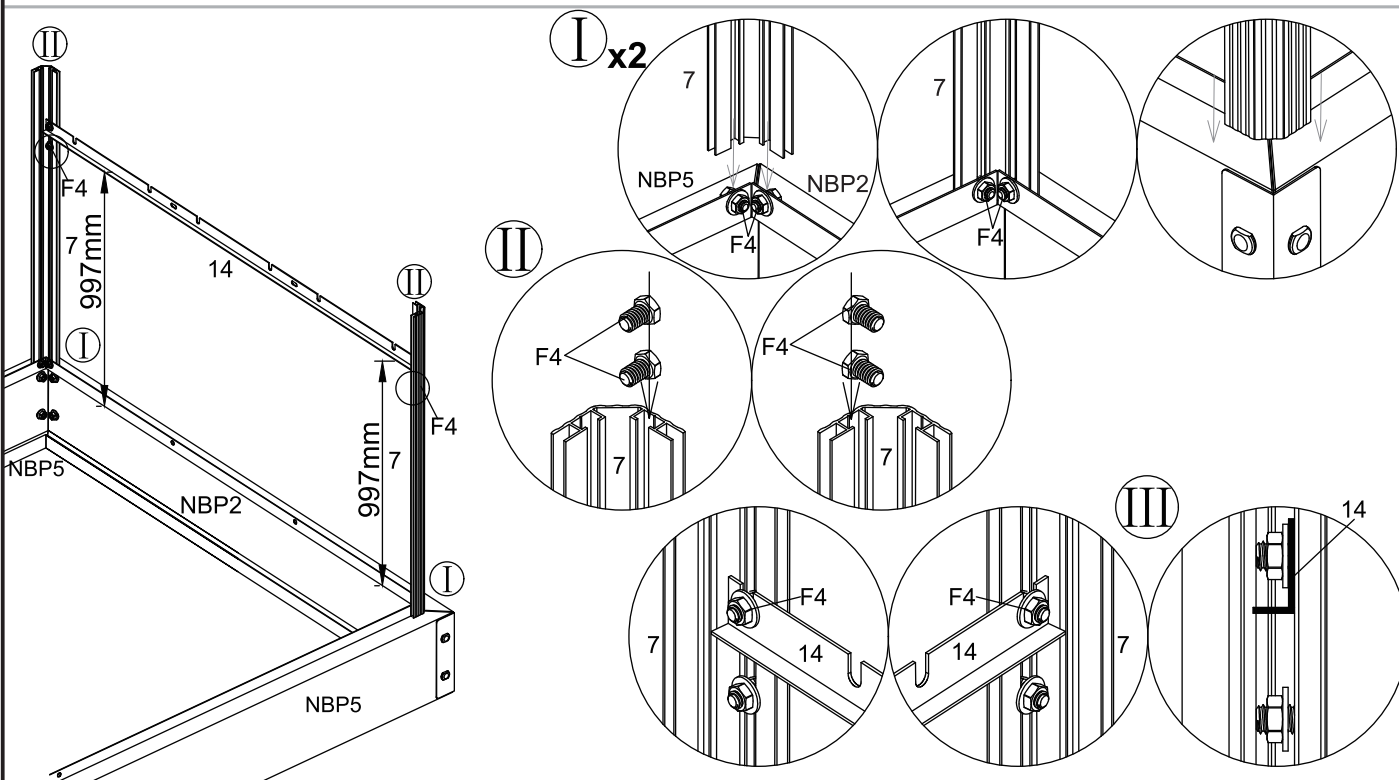
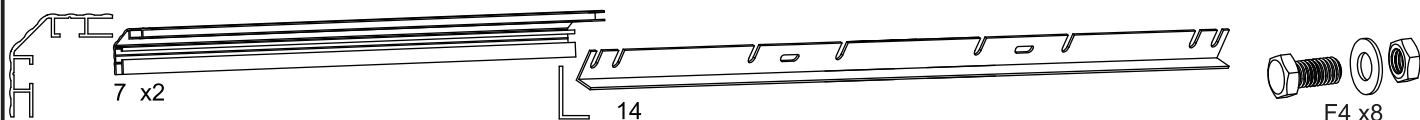

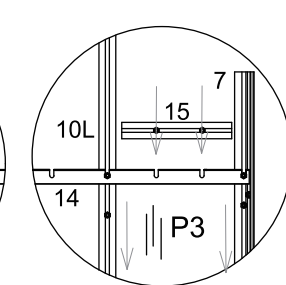
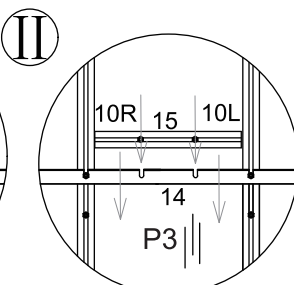
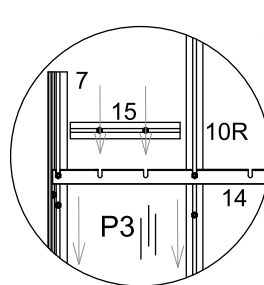
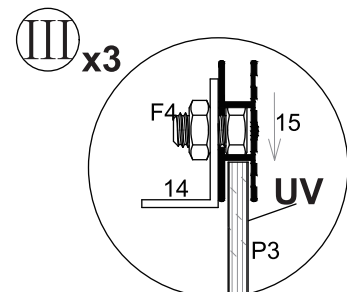
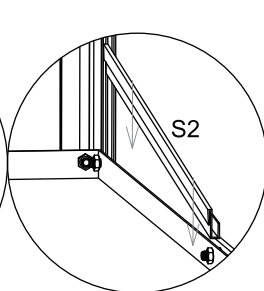
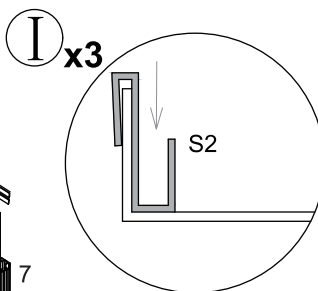
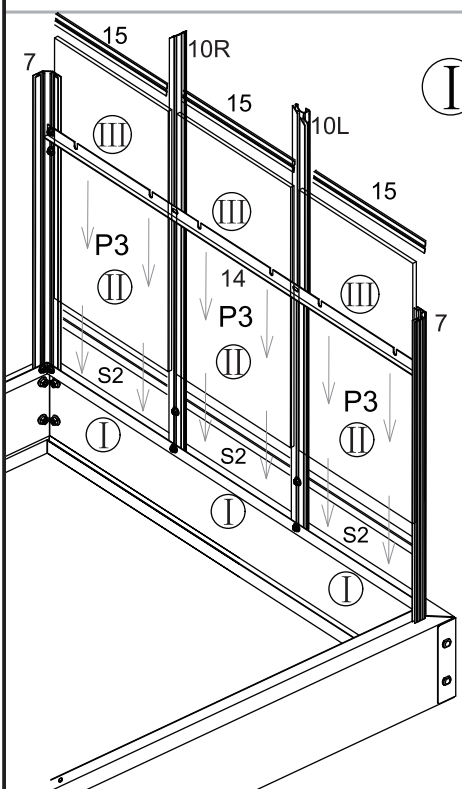
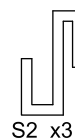
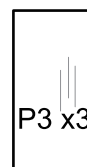
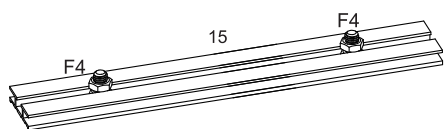
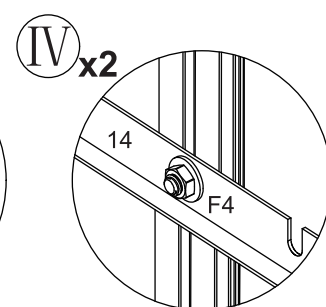
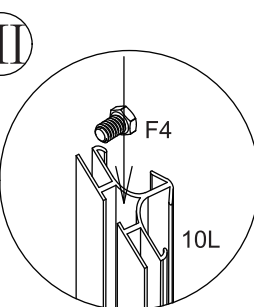
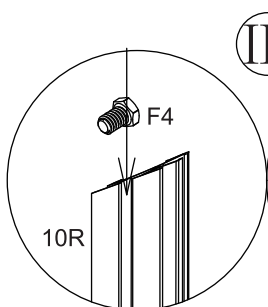
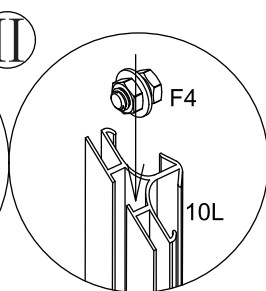
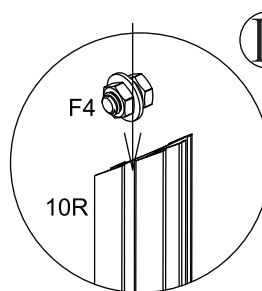
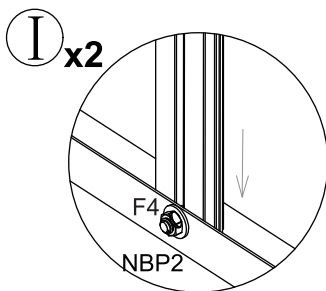
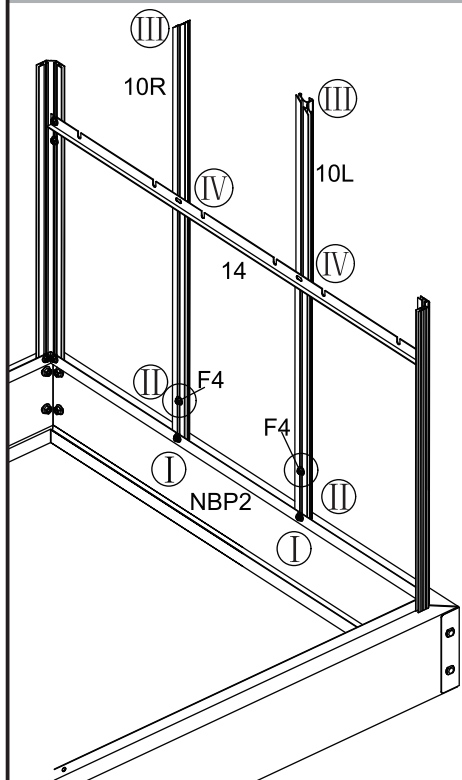
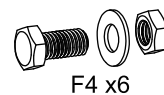
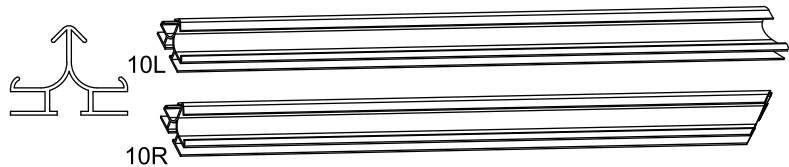

EN\_FRONT WALL  
DE\_FRONT-WAND

08

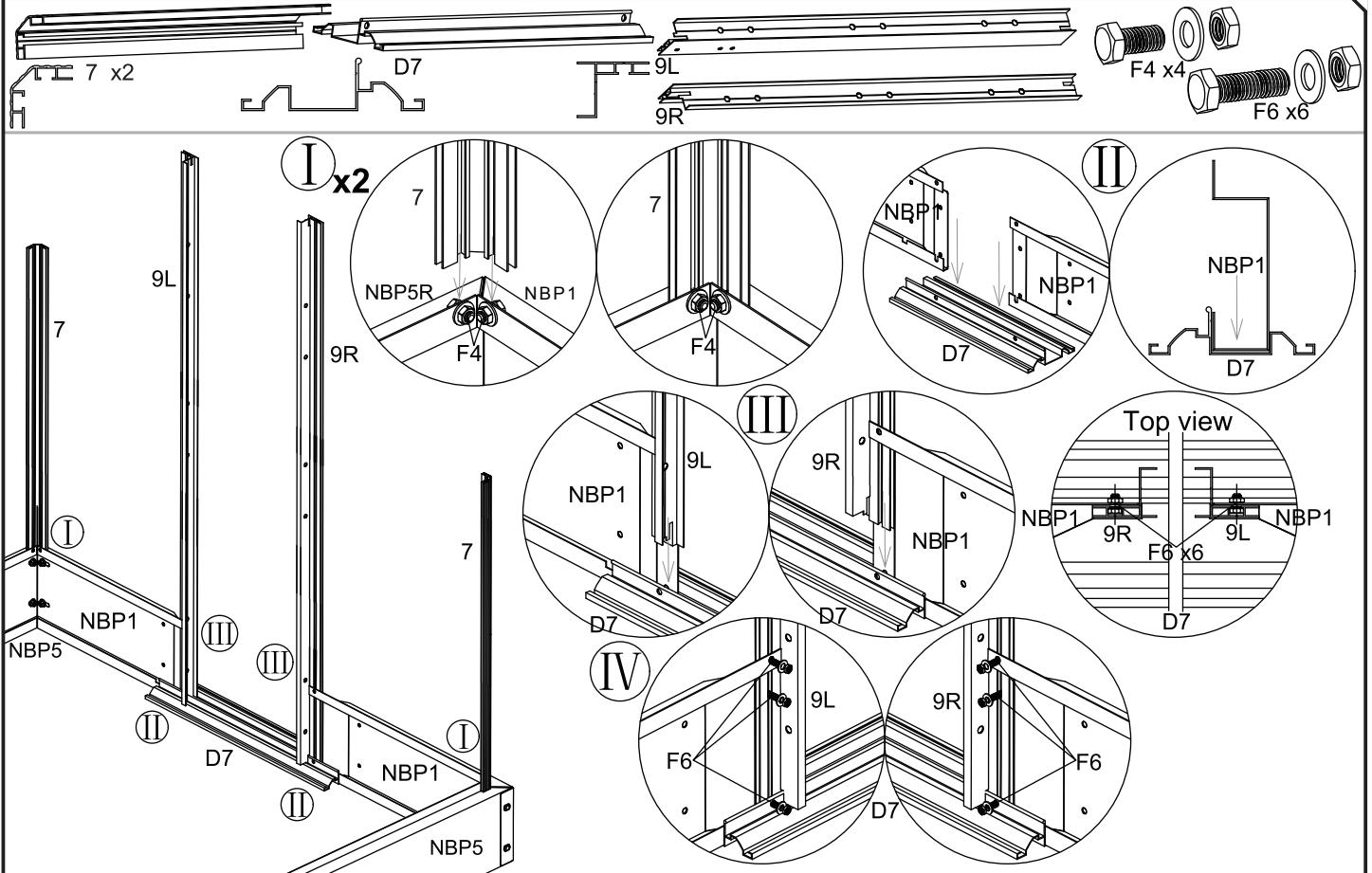

09

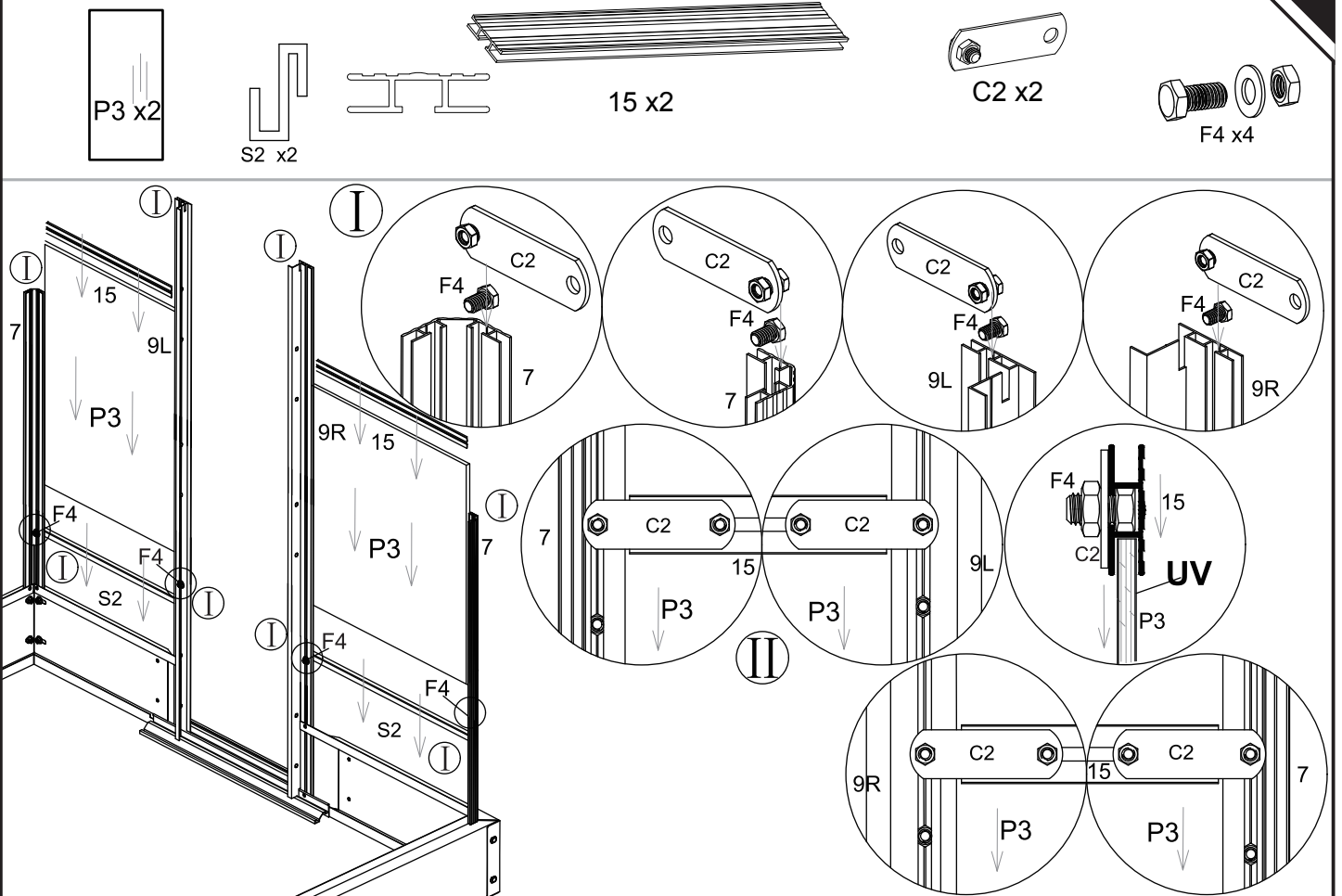



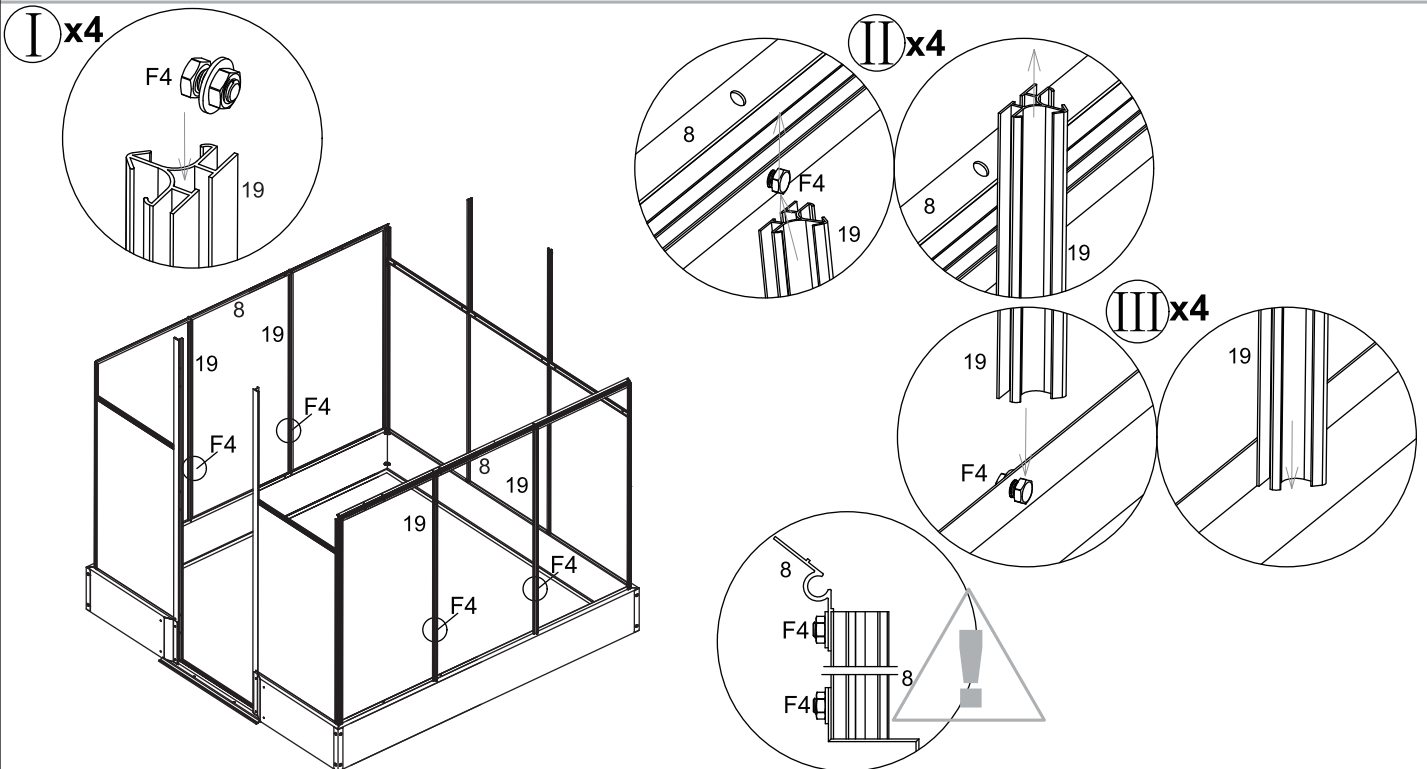
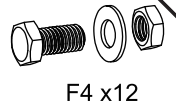
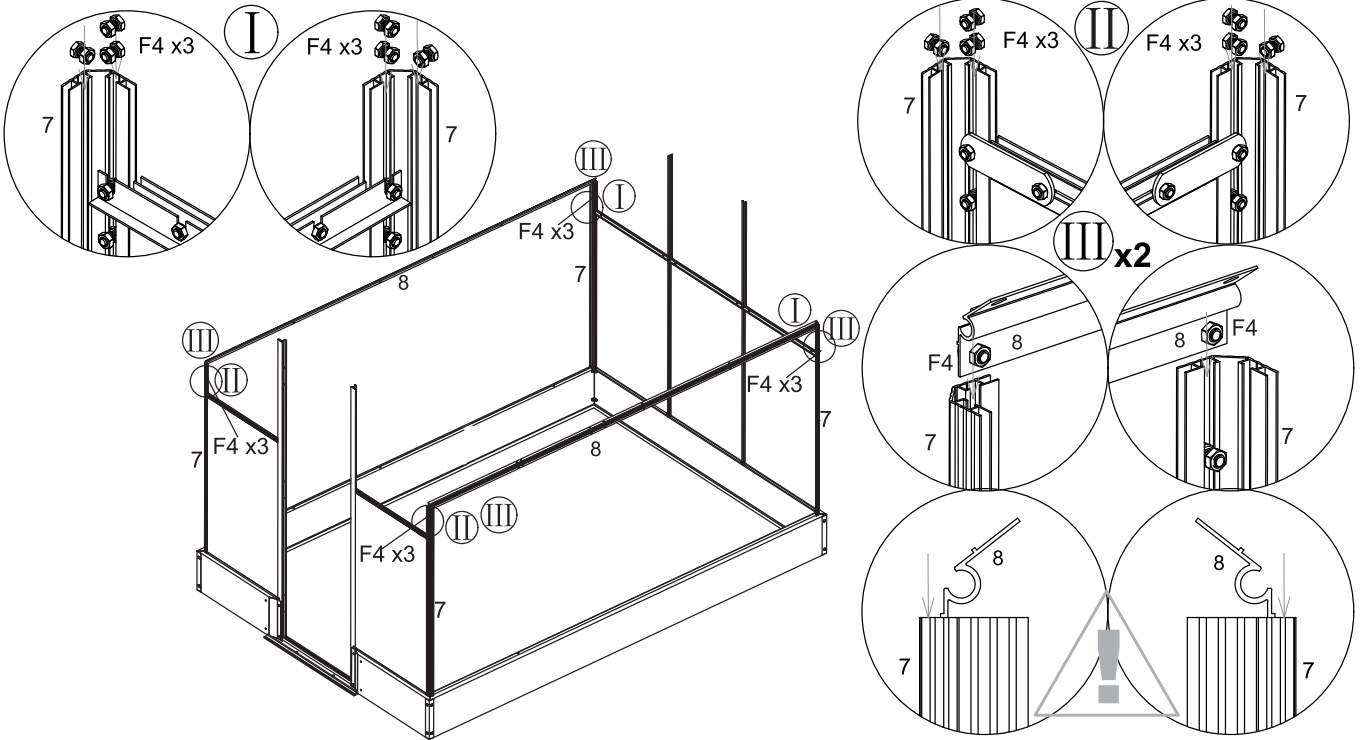
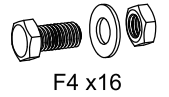
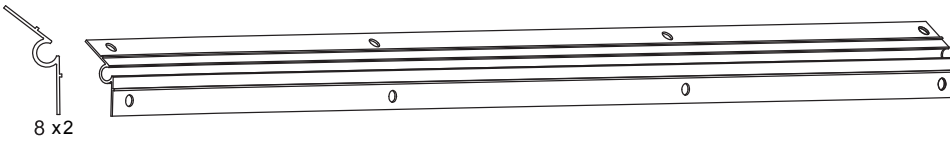



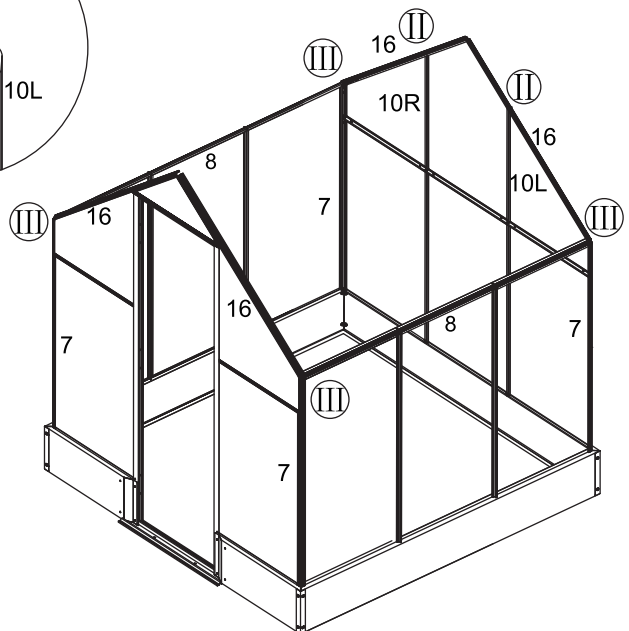
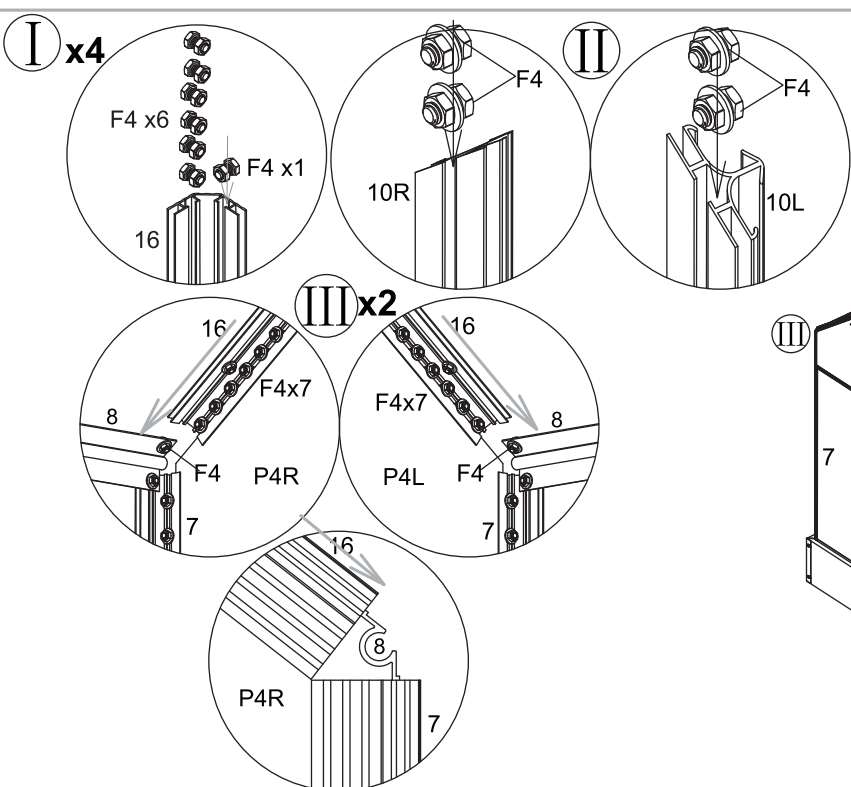
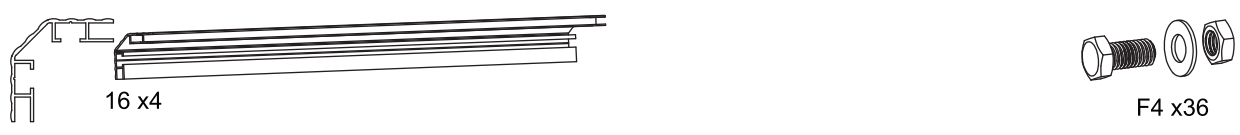
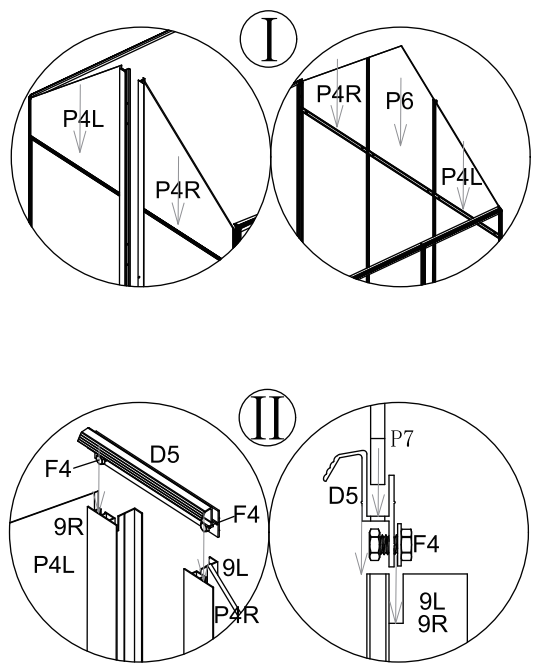
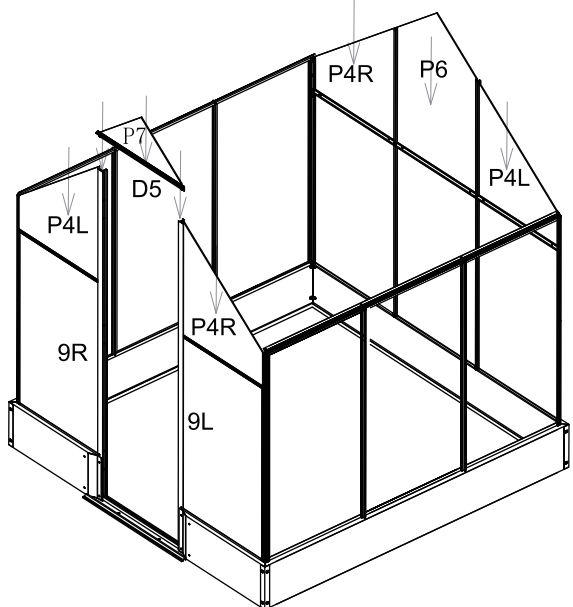
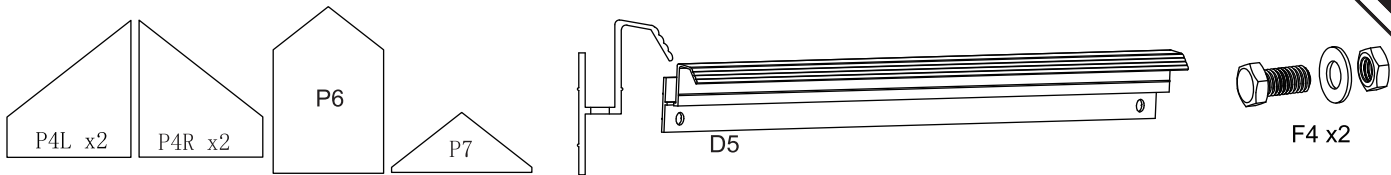

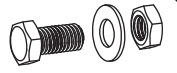
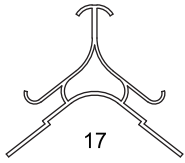

F4 x4

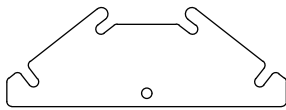
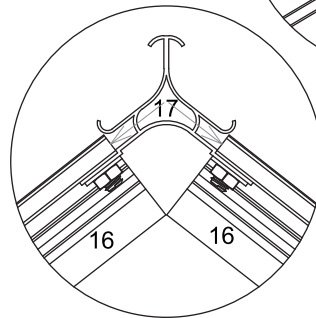
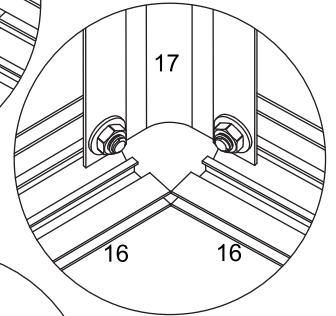
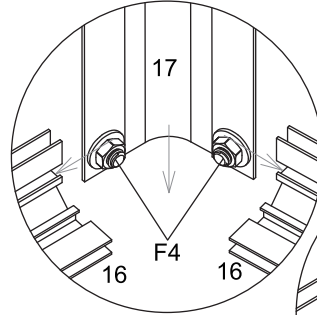
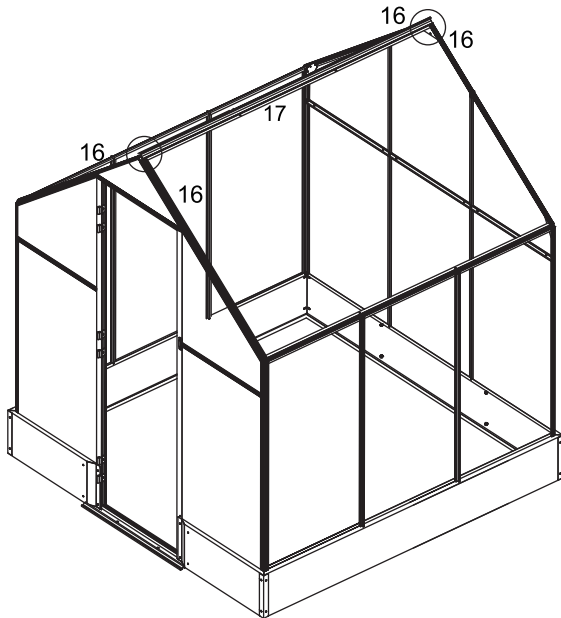

B6

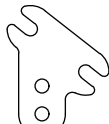

B4 x2

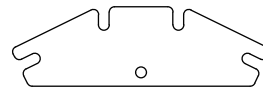

B5 x2

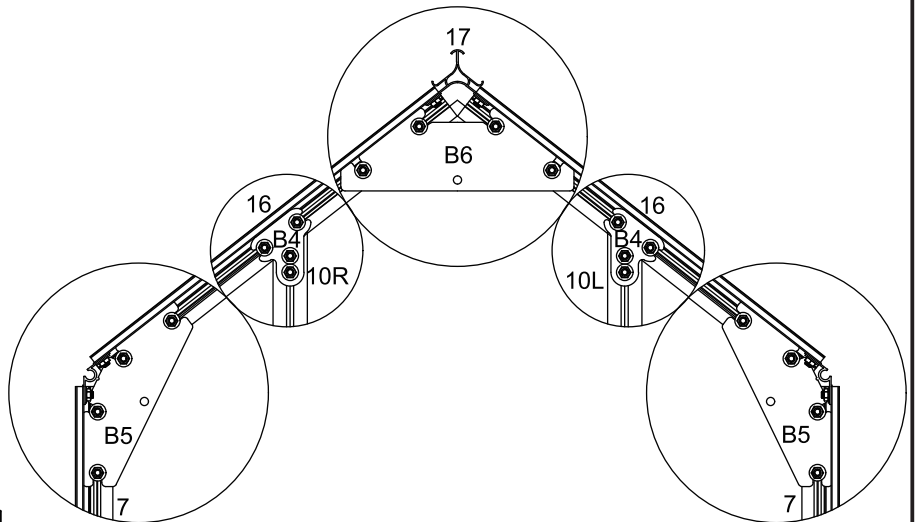
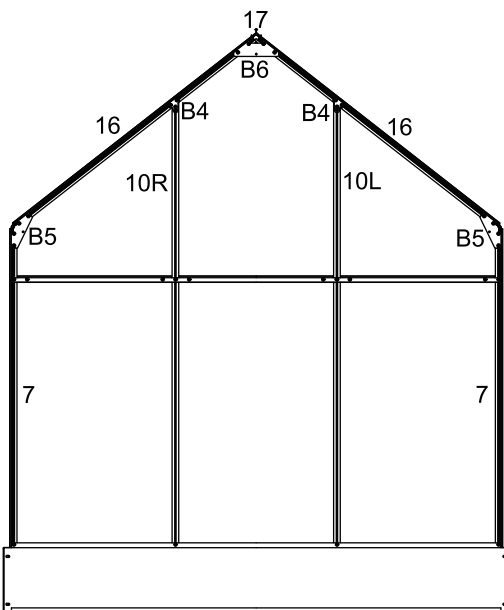

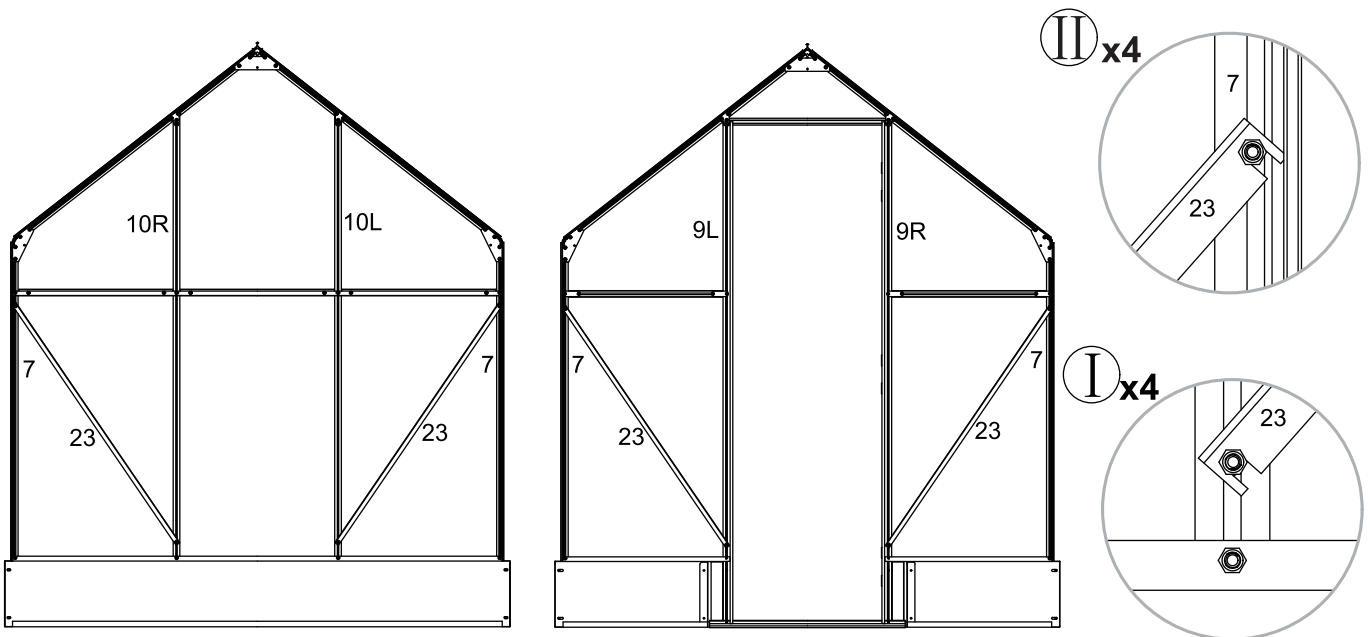
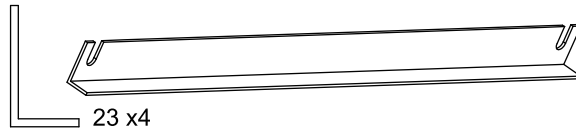
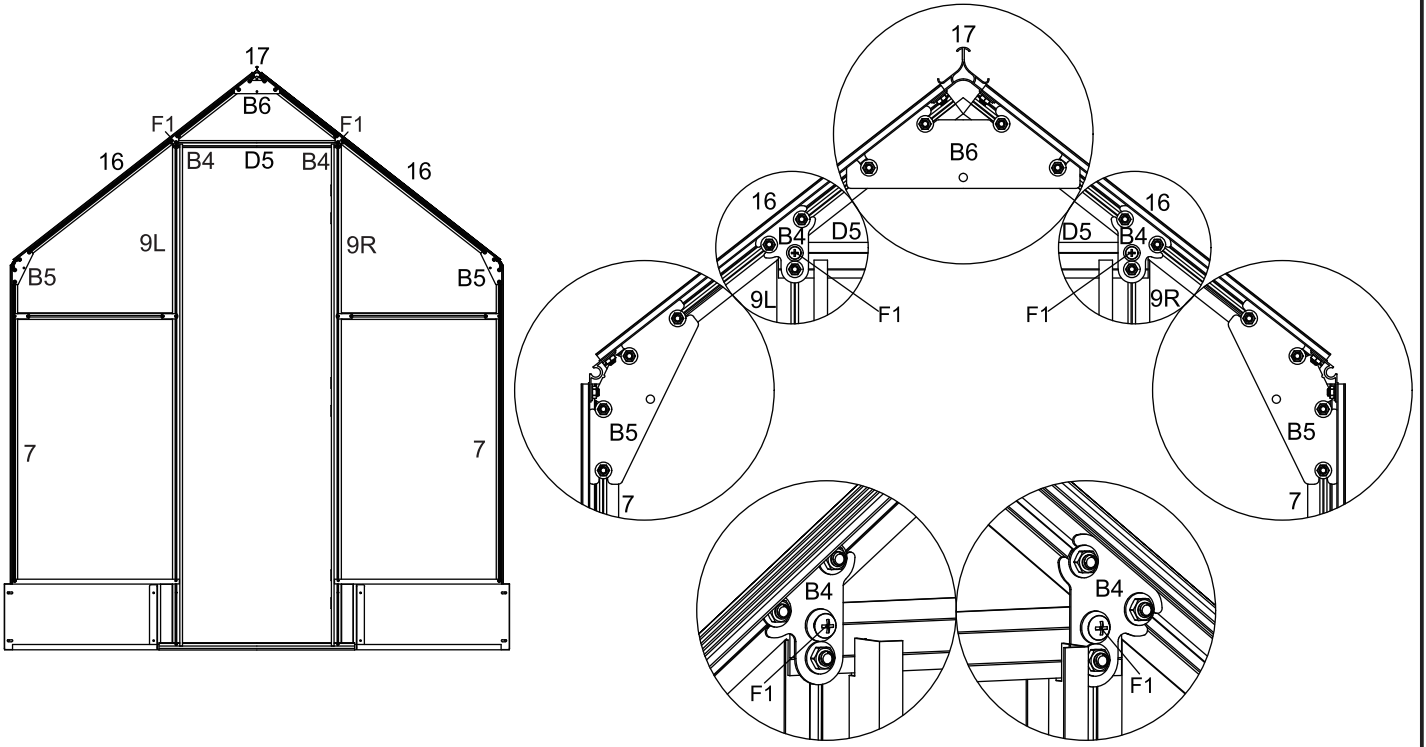
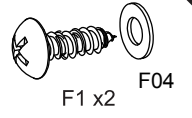
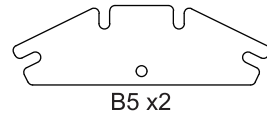
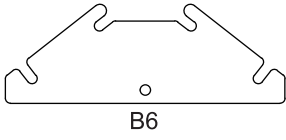

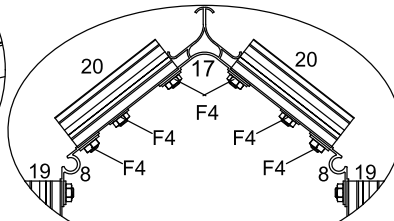
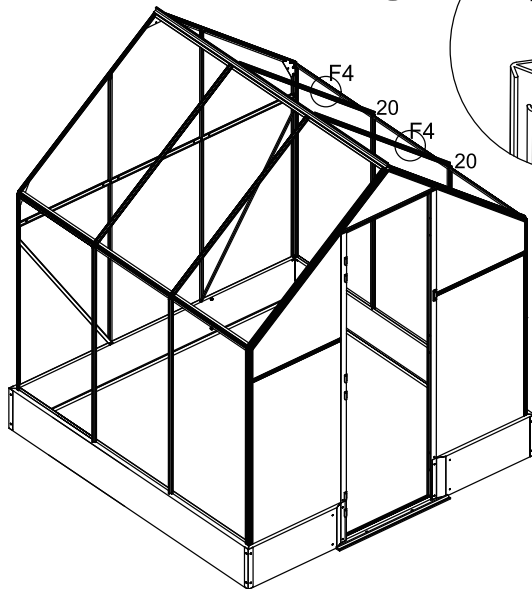
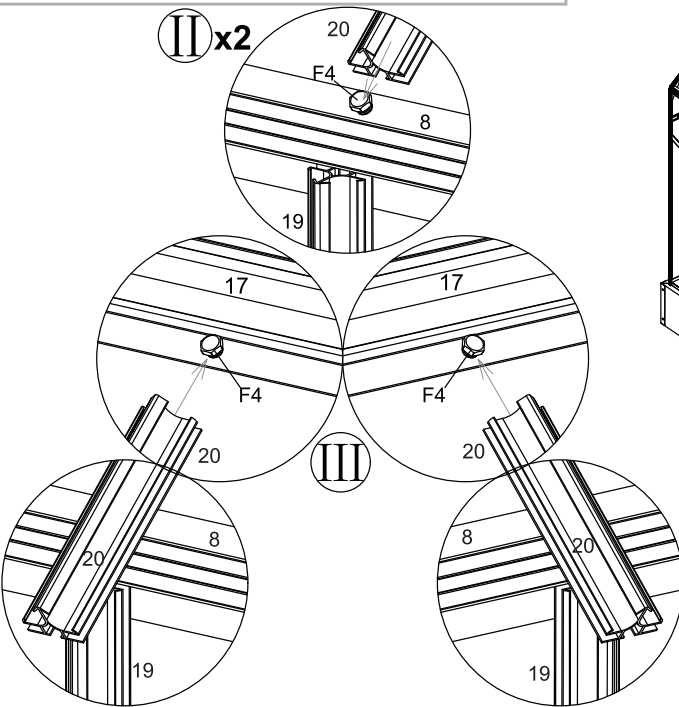
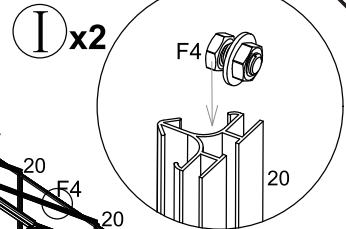
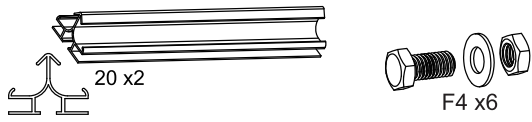
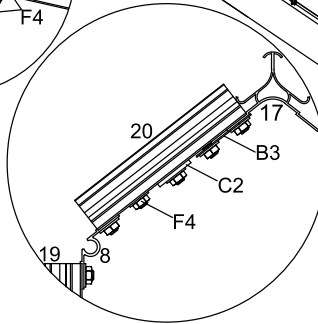
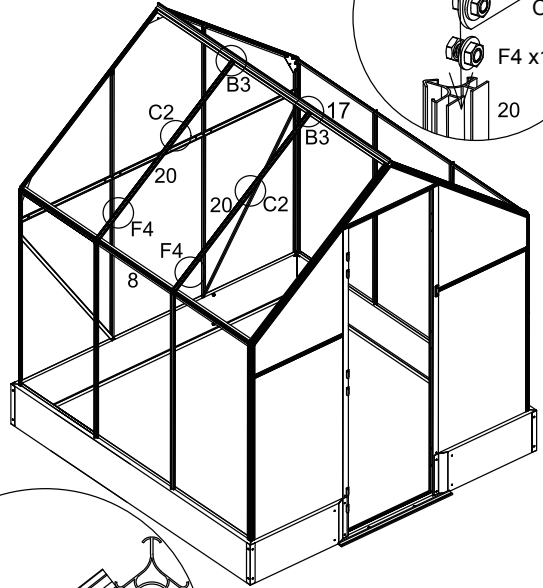
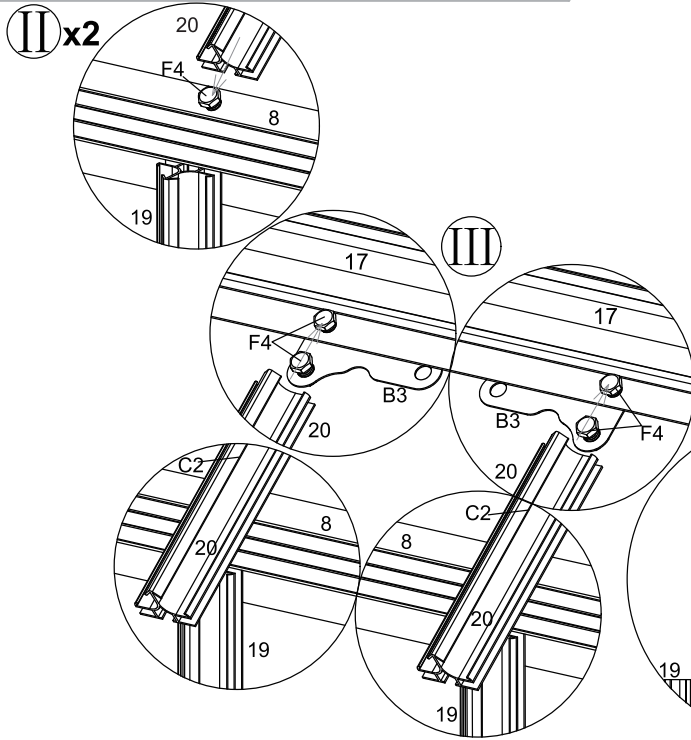
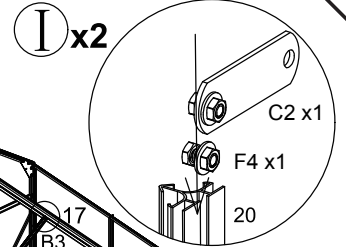
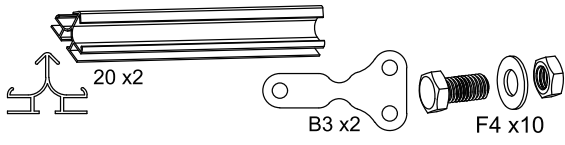

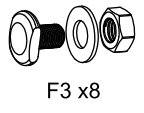
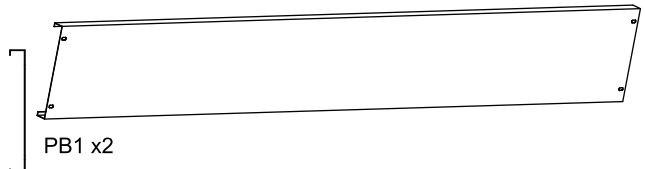
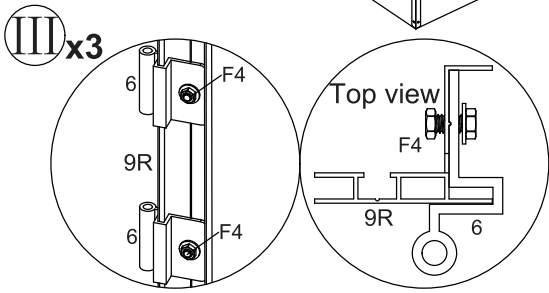
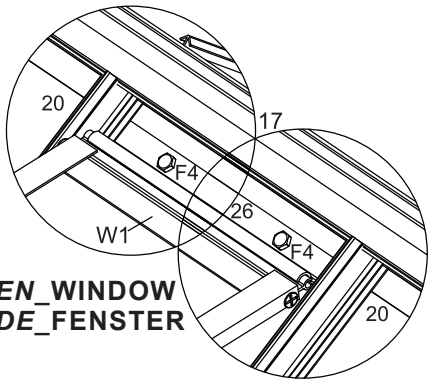
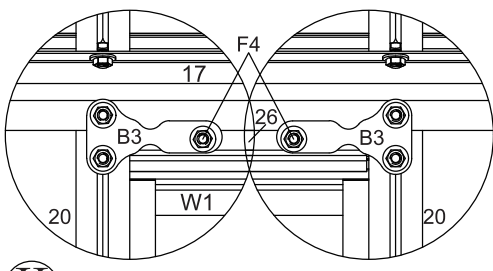
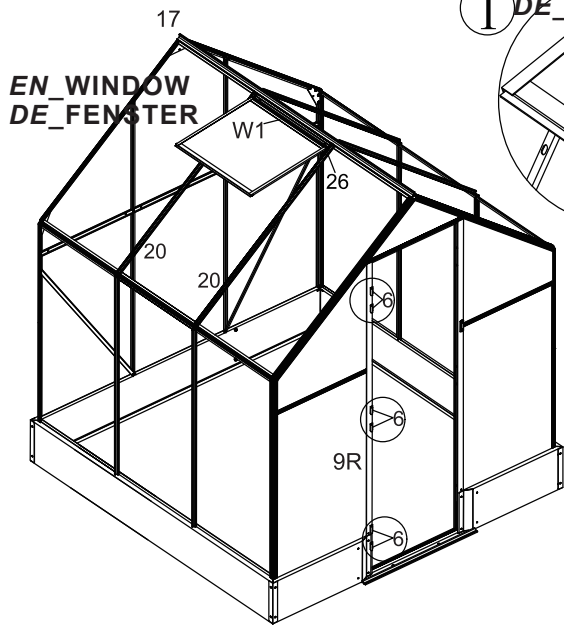
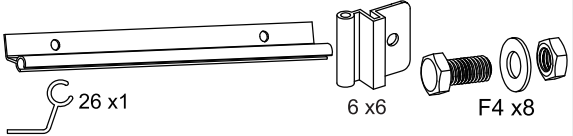
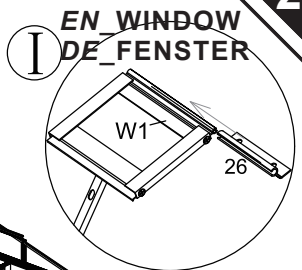

x2

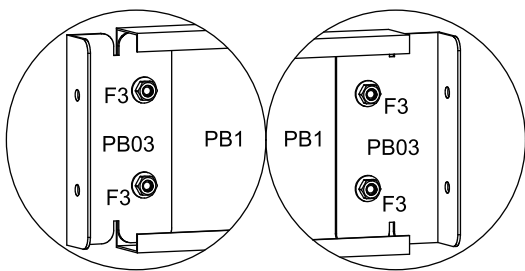
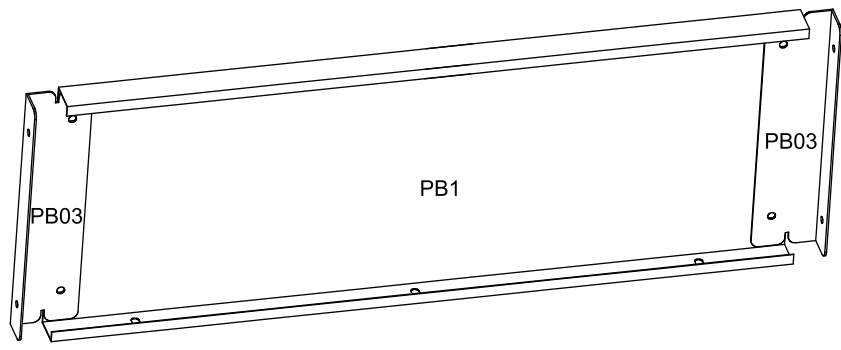



F3 x8

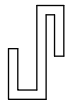
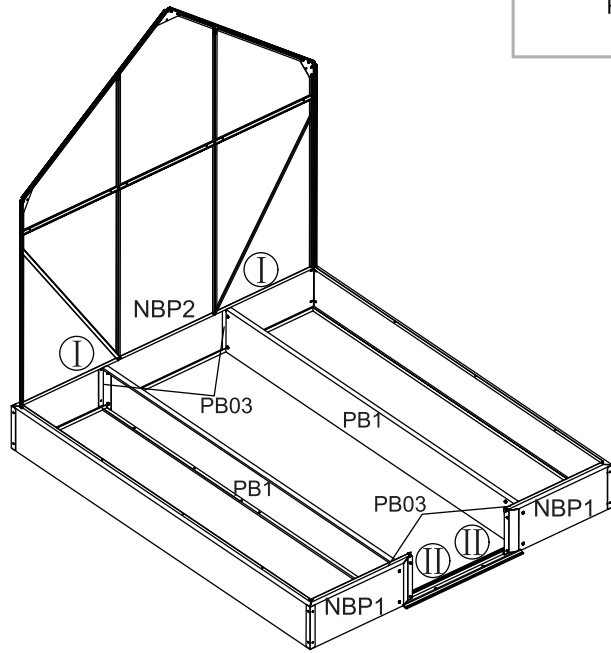
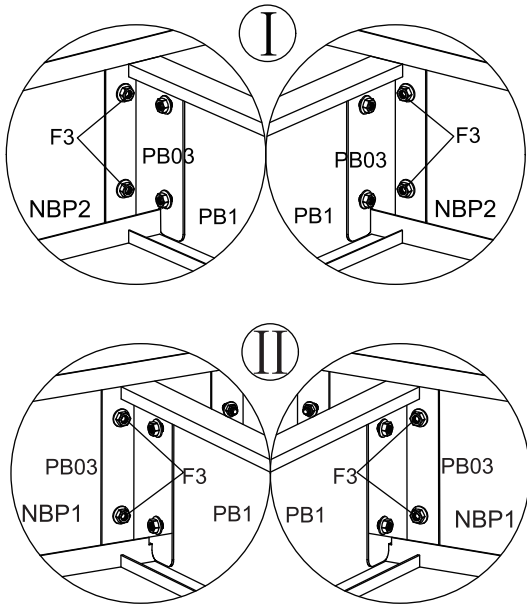

S2 x6

P8 x5

P5 x1

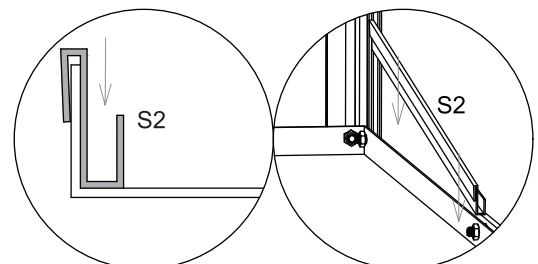
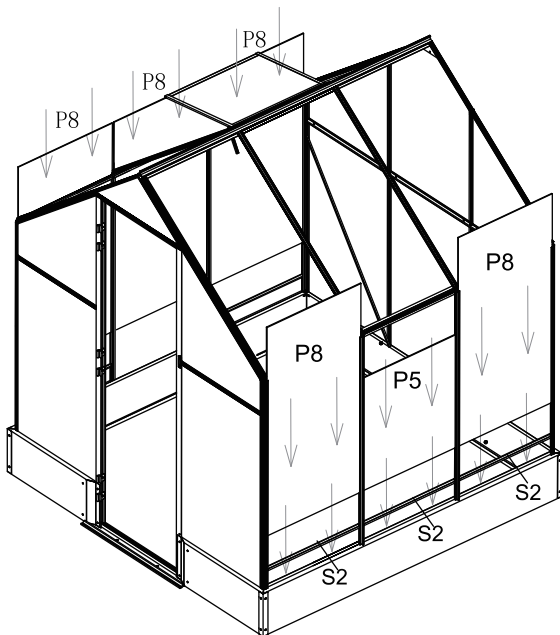

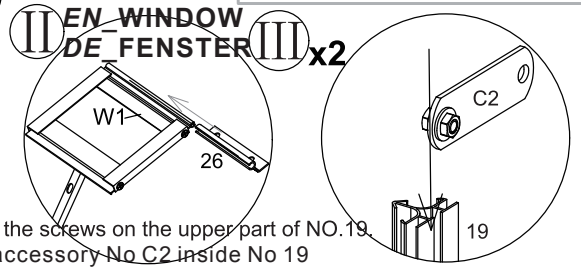
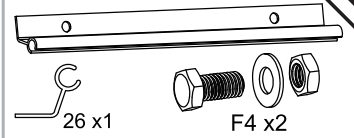
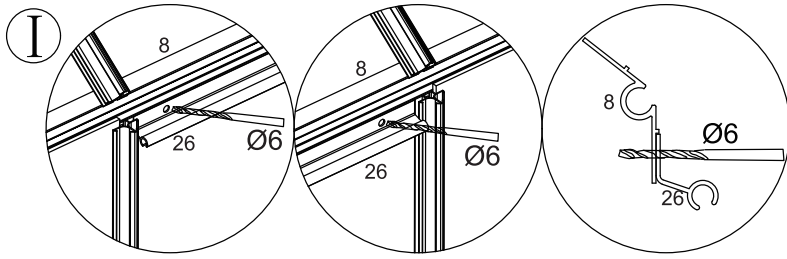

**EN\_Steps:**

1. First remove the screws on the upper part of NO.19.
2. Install the accessory No C2 inside No 19

**DE\_Schritte:**

1. Zuerst die Schrauben am oberen Teil von Nr.19 entfernen.
2. Bitte befestigen Sie Teil # C2 an der Innenseite von Teil #19.

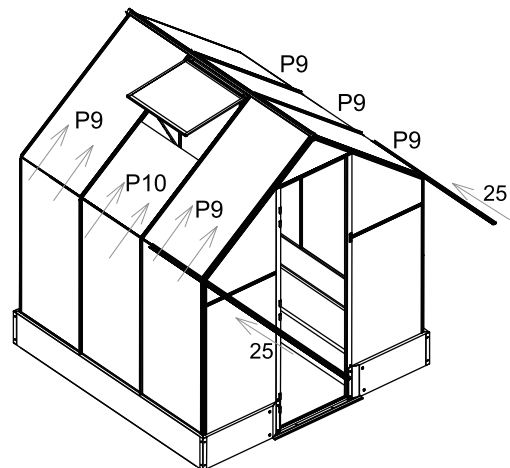
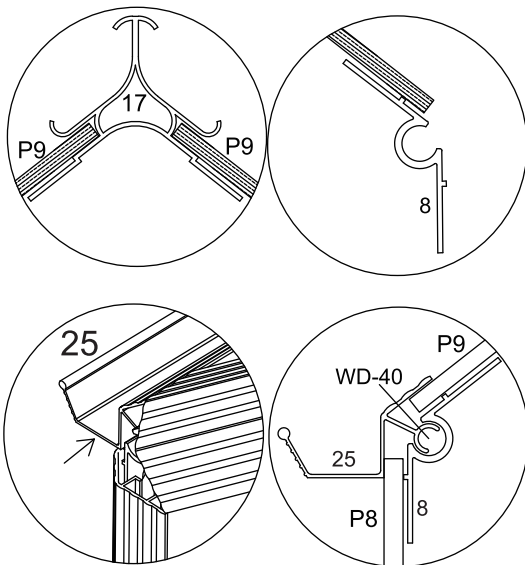
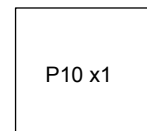
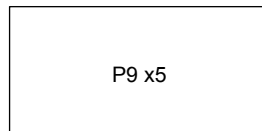
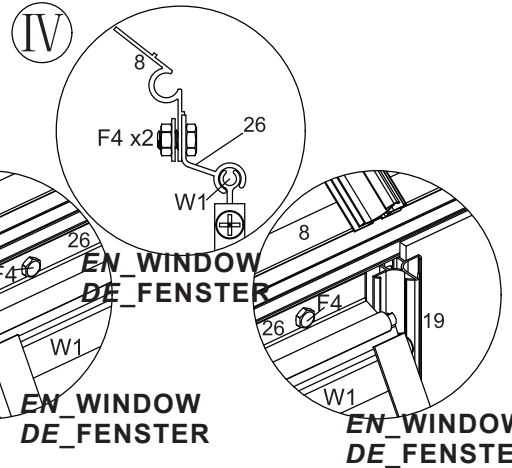
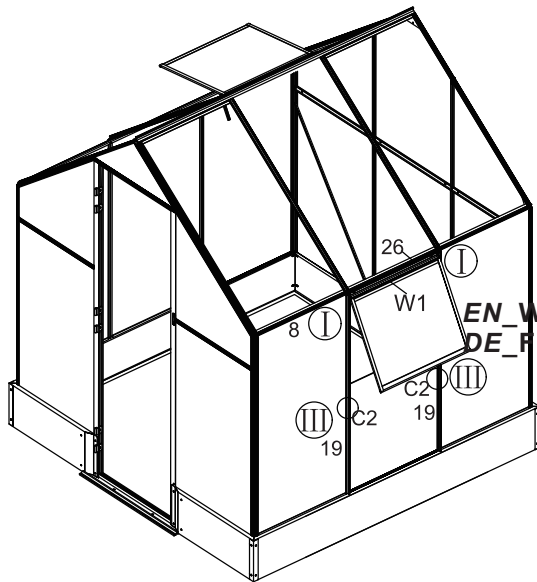

**EN\_It's easier to install WD-40 with grease when using part No 25 in this step**

**DE\_Dieser Montageschritt ist einfacher falls Sie bei #25 Schmieröl zur Montage von WD-40 verwenden.**



**EN\_LEFT WALL AND LEFT TOP**  
**DE\_LINKE WAND UND LINKE OBERSEITE**

26

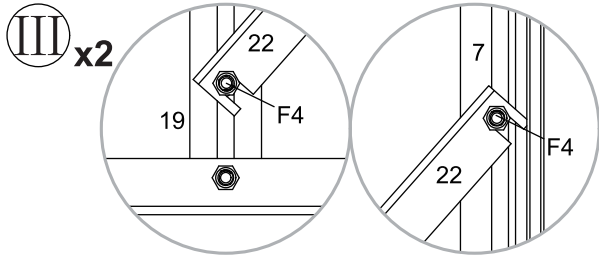
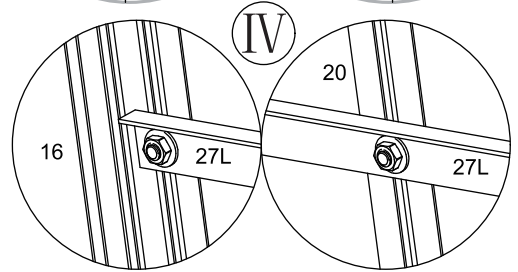
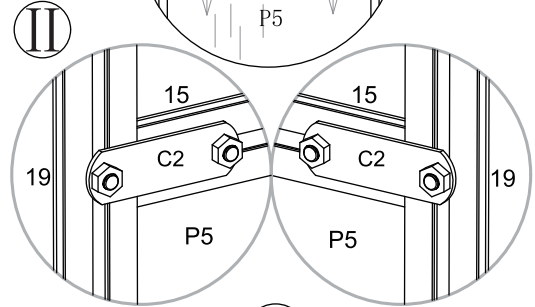
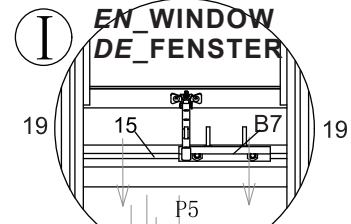
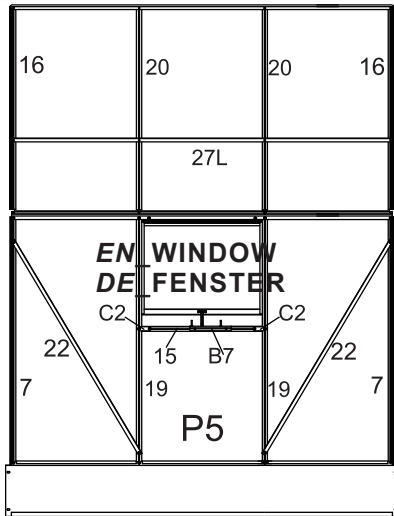
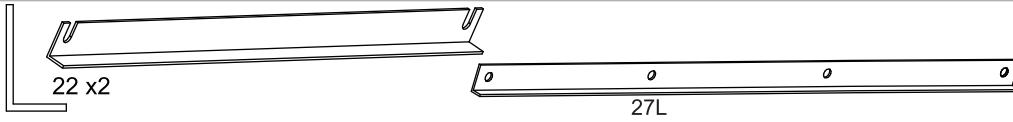

**EN\_RIGHT WALL AND LEFT TOP**  
**DE\_RECHTE WAND UND LINKS OBEN**

27

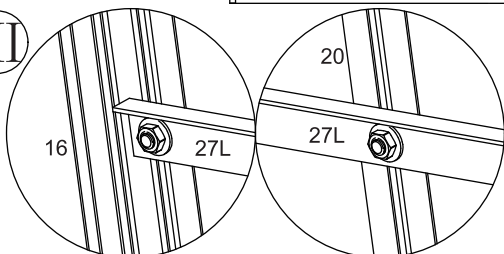
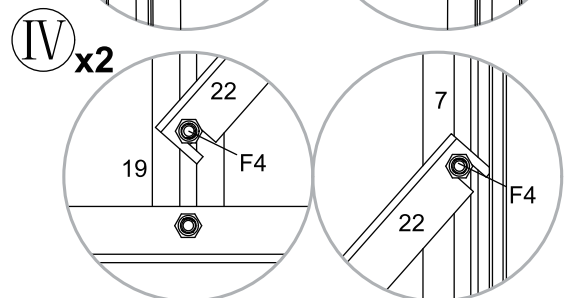
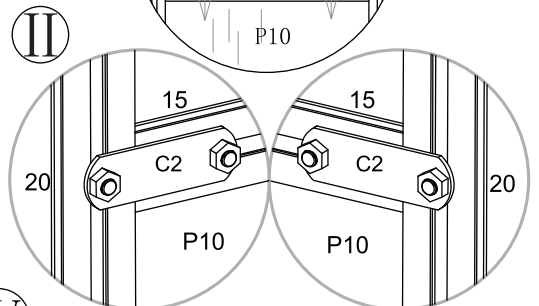
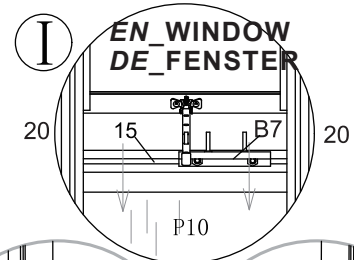
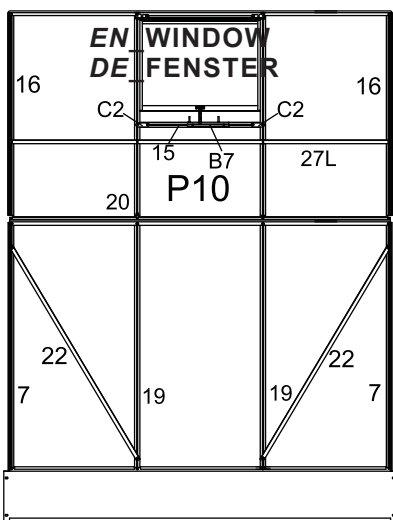
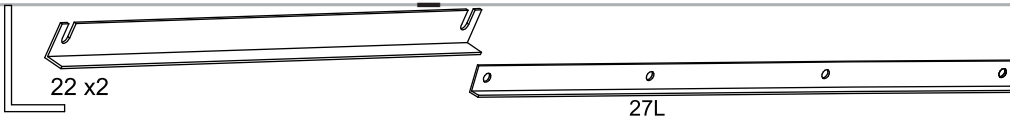



**EN\_** Note the use of the window  
**DE\_** Beachten Sie die Verwendung der Fenster

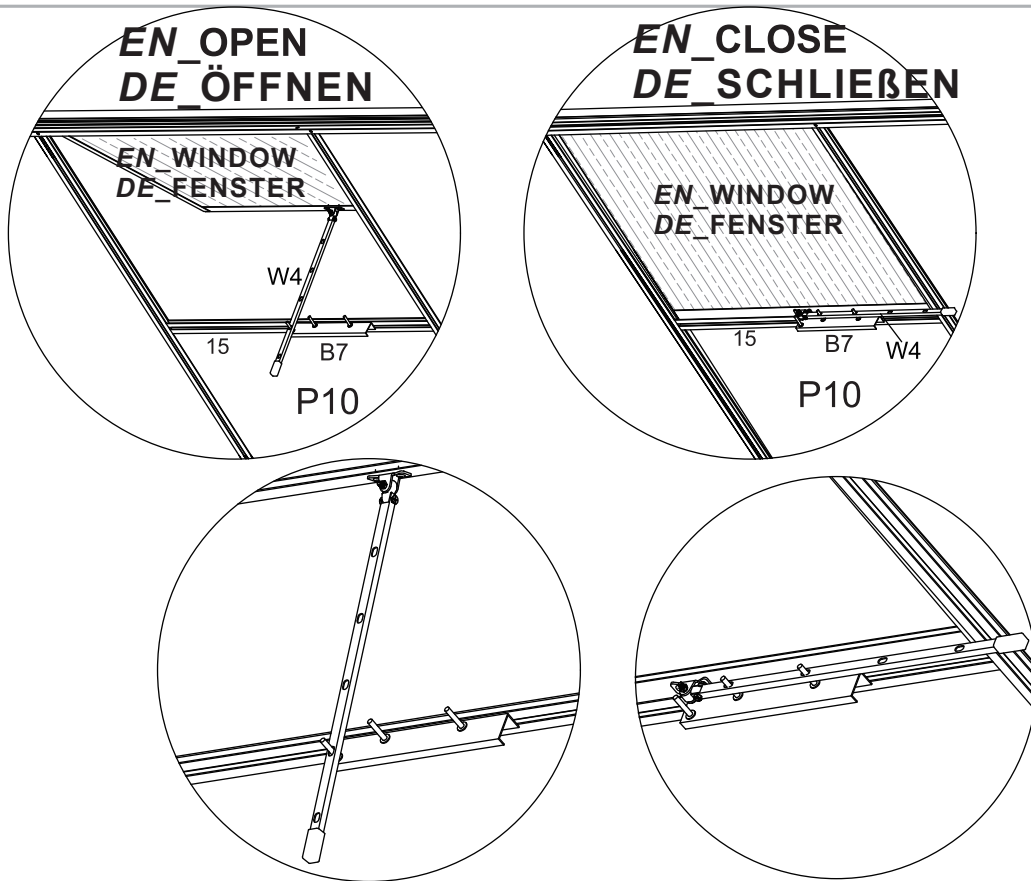

**EN\_** Front wall door installation  
**DE\_** Installation der Vorderwandtür

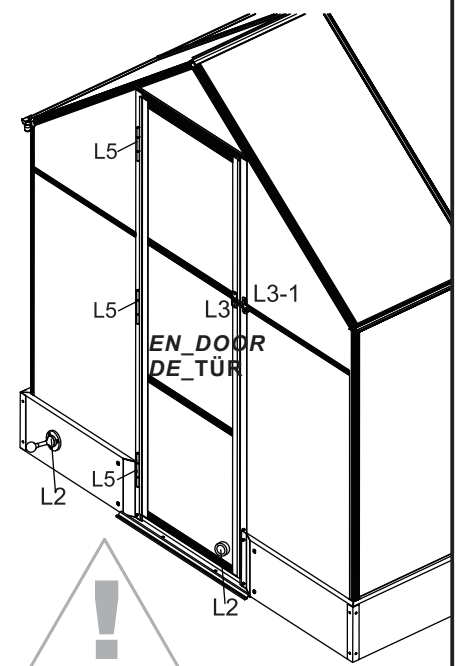
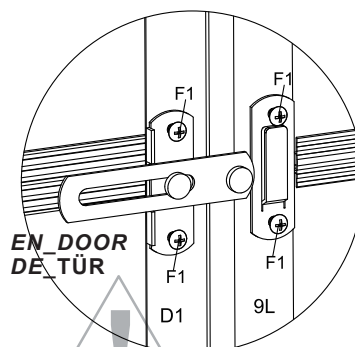
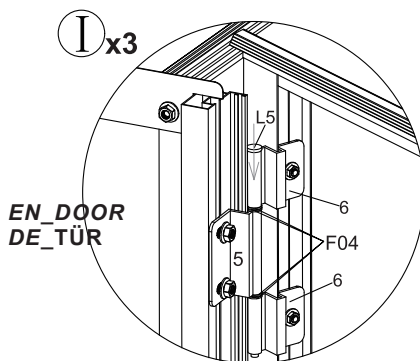

**EN\_** Installation steps:

1. Move the greenhouse to prevent the location from moving.
2. The door can open the door normally and close the door.
3. NO.L3 and NO.L3-1 should be in the same horizontal position.
4. Fasten the NO.F1 screw directly with the electric wrench crosshead.

**DE\_** Installationsschritte:

1. Verschieben Sie das Gewächshaus, um ein Verschieben des Standortes zu verhindern.
2. Die Tür kann sich normal öffnen und die Tür schließen.
3. Nr. L3 und Nr. L3-1 sollten sich in der gleichen horizontalen Position befinden.
4. Befestigen Sie die Schraube Nr. F1 direkt mit der Traverse des Elektroschlüssels.

**EN\_** Determine the appropriate location before installing the door touch L2.

**DE\_** Bestimmen Sie die geeignete Stelle, bevor Sie den Türkontakt L2 installieren.

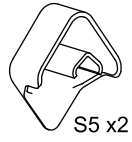

S5 x2

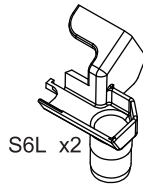

S6L x2

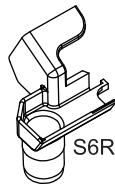

S6R x2



EN\_SILICON  
DE\_Silikon

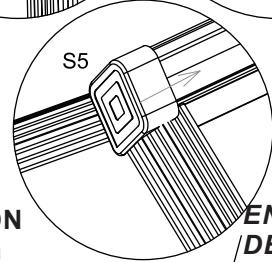
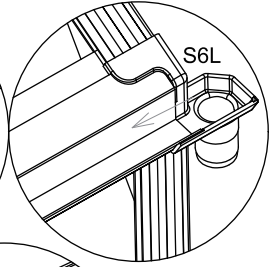
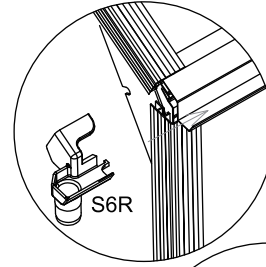
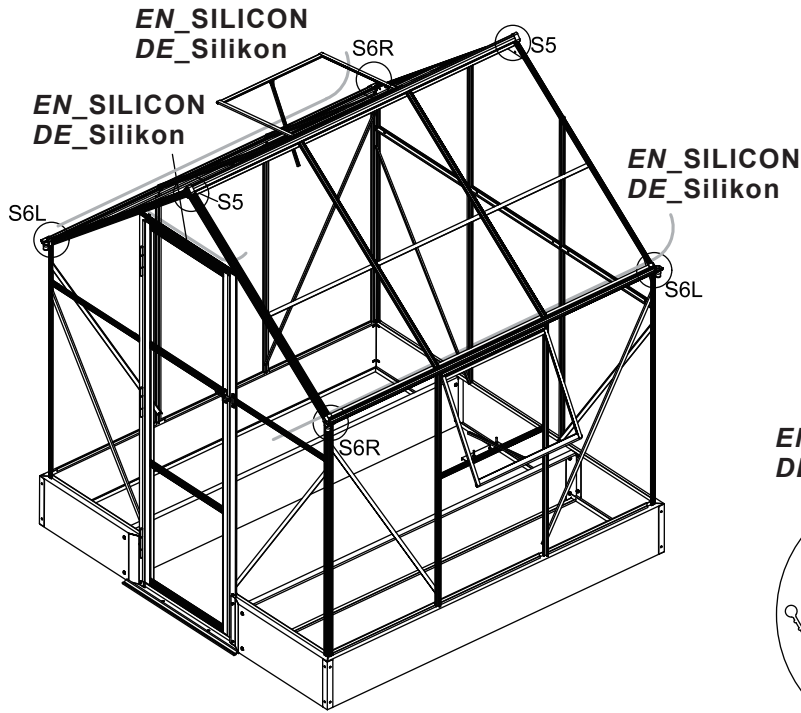

EN\_SILICON  
DE\_Silikon

EN\_SILICON  
DE\_Silikon

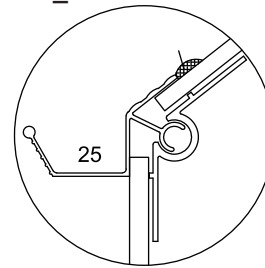

25

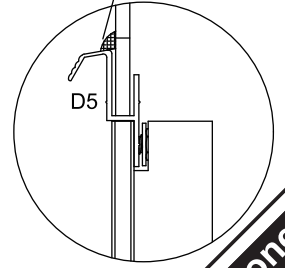

D5

Done

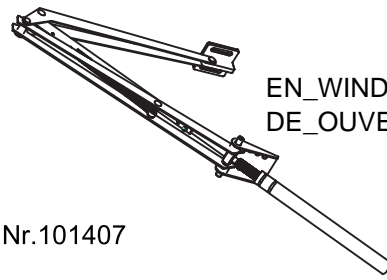

EN\_WINDOW OPENER  
DE\_OUVERTURE DE FENÊTRE

Art.Nr.101407

GB

#### IMPORTANT

- Reading the comments, instruction and attention CAREFULLY before assembly.
- Follow the assemble manual step by step please.

⇒ Preparing the unit for fitting

Step 1-Insert the hydraulic slider through piston, Advance to the telescopic position ,fix it by turning the rotated pole .

Step 2-Lift the bar, turning the slided arm to make its holes reach to the holes on telescopic position.

Step 3-Insert bolt, fixed rotated pole and auto vent bar.

Step 4-Pull the bolt, turning the rotated pole to adjust the window close scale.

⇒ Fitting the unit

- Follow the next steps for fitting the unit according to the greenhouse model you have purchased.

DE

#### WICHTIG

- Lesen Sie diese Bedienungsanleitung vordem Aufbau gründlich durch.
- Befolgen Sie die Aufbauanleitung Schritt für Schritt.

⇒ Legen Sie sich vordem Aufbau Werkzeug zurecht.

Schritt 1: Schieben Sie den hydraulischen Schieber in den Kolben und fixieren Sie ihn durch Andrehen (normales, rechtsdrehendes Innengewinde).

Schritt 2: Heben Sie die Gelenkstange an und drehen Sie, bis die Löcher der Stange an der gleichen Position sind, wie die Löcher im Teleskoprohr (zahlreiche Umdrehungen!!!).





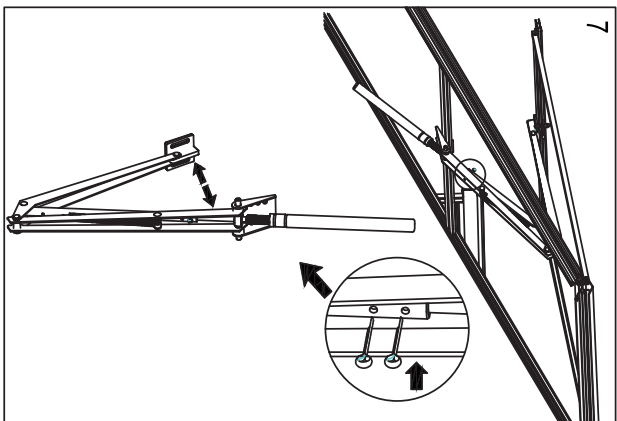
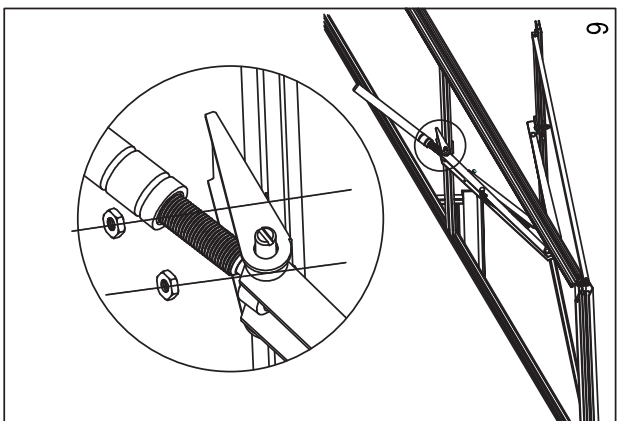
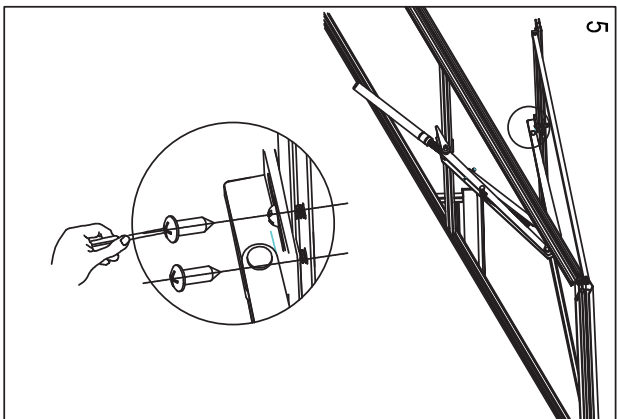
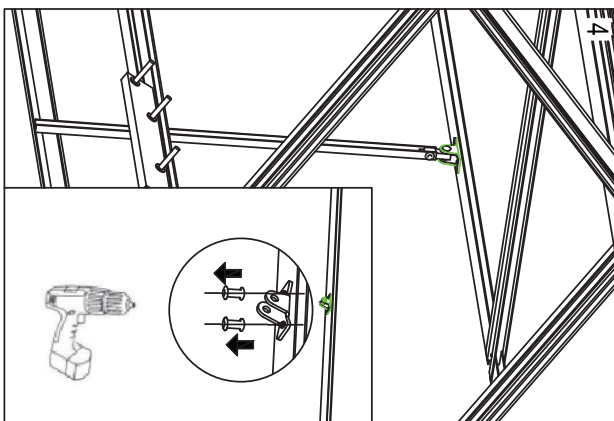
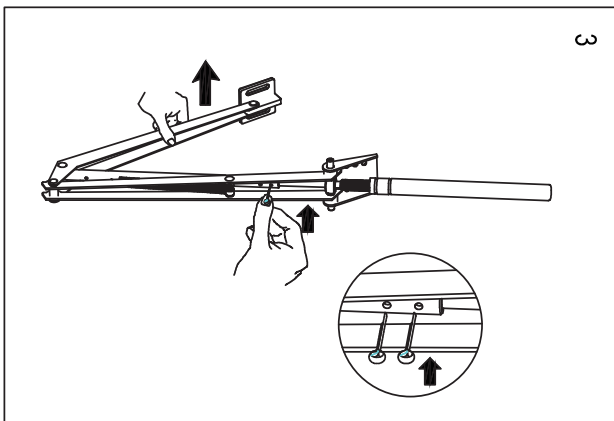
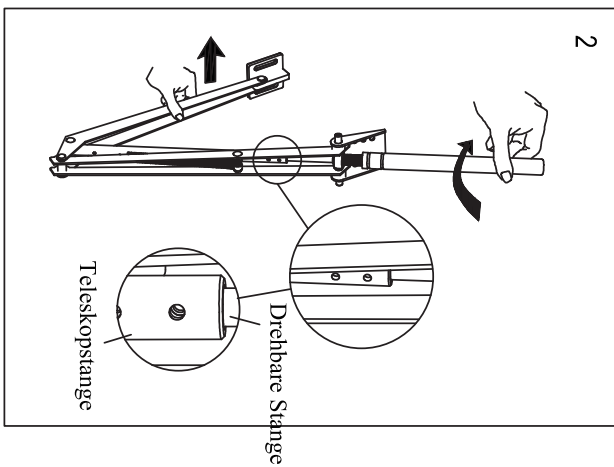
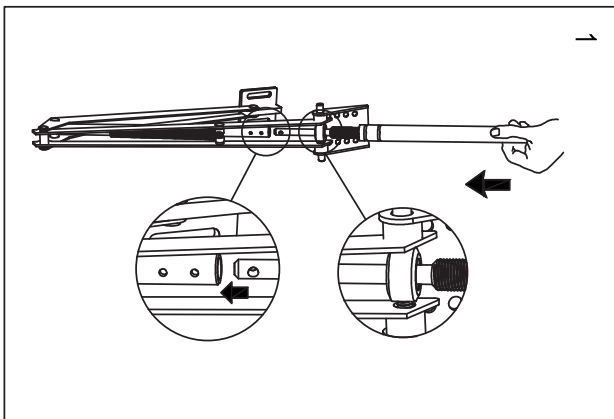

Schritt 3: Schieben Sie den Splint ein und biegen Sie ihn auf, um damit die bewegliche Stange am Fensteröffner zu fixieren.

Schritt 4: Drücken Sie den Stift und drehen die bewegliche Stange um den Fensteröffner einzustellen.

Bringen Sie die Einheit an, wie nachfolgend illustriert.



PARTS LIST

PART	NO.	Qty.
	1	1
	1	1
	S1	2
	F1	2
	F2	2
	F3	1

If you have any questions, please contact our customer care center, Our contact details are below:

**US**

 001-877-644-9366

 customerservice@aosom.com

Imported by Aosom LLC  
27150 SW Kinsman Rd Wilsonville, OR 97070 USA  
MADE IN CHINA

If you have any questions, please contact our customer care center, Our contact details are below:

**UK**

 0044-800-240-4004

 enquiries@mhstar.co.uk

IMPORTER ADDRESS:  
MH STAR UK LTD  
Unit 27, Perivale Park,  
Horsenden lane South  
Perivale, UB6 7RH  
MADE IN CHINA

If you have any questions, please contact our customer care center, Our contact details are below:

**CA**

Si vous avez la moindre question, veuillez contacter notre centre d'assistance à la clientèle, Nos coordonnées sont les suivantes:

 416-792-6088

 customerservice@aosom.ca

Imported by Aosom Canada Inc.  
7270 Woodbine Avenue, Unit 307, Markham,  
Ontario Canada L3R 4B9  
MADE IN CHINA

Importé par Aosom Canada Inc.  
7270 Woodbine Avenue, unité 307, Markham,  
Ontario Canada L3R 4B9  
FABRIQUÉ EN CHINE

Wenn Sie Fragen haben, wenden Sie sich bitte an unser Kundendienstzentrum, Unsere Kontaktdaten stehen unten:

**DE**

 0049-0(40)-88307530

 service@aosom.de

ADRESSE DES IMPORTEUR/Hersteller/REP:  
MH Handel GmbH Wendenstraße 309 D-20537  
Hamburg  
Germany  
WWW.AOSOM.DE  
IN CHINA HERGESTELLT

In caso di dubbio, si prega di contattare il nostro centro assistenza clienti, I nostri dettagli di contatto sono di seguito:

**IT**

 0039-0249471447

 clienti@aosom.it

IMPORTATO DA/Produttore/REP: AOSOM Italy srl  
Centro Direzionale Milanofiori Strada 1 Palazzo F1  
20057 Assago (MI)  
P.I.: 08567220960  
WWW.AOSOM.IT  
FATTO IN CINA

Si tiene alguna pregunta, comuníquese con nuestro Centro de Atención al Cliente, Nuestros datos de contacto son los siguientes:

**ES**

 0034-931294512

 atencioncliente@aosom.es

IMPORTADOR/Fabricante/REP:  
SPANISH AOSOM, S.L.  
C/ROC GROS, Nº15.08550, ELS HOSTALET DE  
BALENYÀ, SPAIN.  
B66295775  
WWW.AOSOM.ES  
HECHO EN CHINA

Se tiver alguma dúvida, por favor contacte o nosso Centro de Atendimento ao Cliente, Os nossos dados de contacto são os seguintes:

**PT**

 0034-931294512

 info@aosom.pt.

IMPORTADOR/Fabricante/REP: SPANISH  
AOSOM, S.L C.ROC GROS N.15, 08550. ELS  
HOSTALET DE BALENYÀ  
WWW.AOSOM.PT  
FEITO NA CHINA

Si vous avez la moindre question, veuillez contacter notre centre d'assistance à la clientèle, Nos coordonnées sont les suivantes:

**FR**

 0033-1-84166106  aosom@mhfrance.fr

Importé par/Fabricant/REP: MH FRANCE 2 Rue Maurice Hartmann 92130 Issy Les Moulineaux  
France  
WWW.AOSOM.FR  
FABRIQUÉ EN CHINE



**FR**

**DONNEZ  
OU  
RECYCLEZ**



OU



OU



ASSOCIATION LIVRAISON DÉCHÈTERIE

Adresses sur [quefairedemesdechets.fr](http://quefairedemesdechets.fr)