

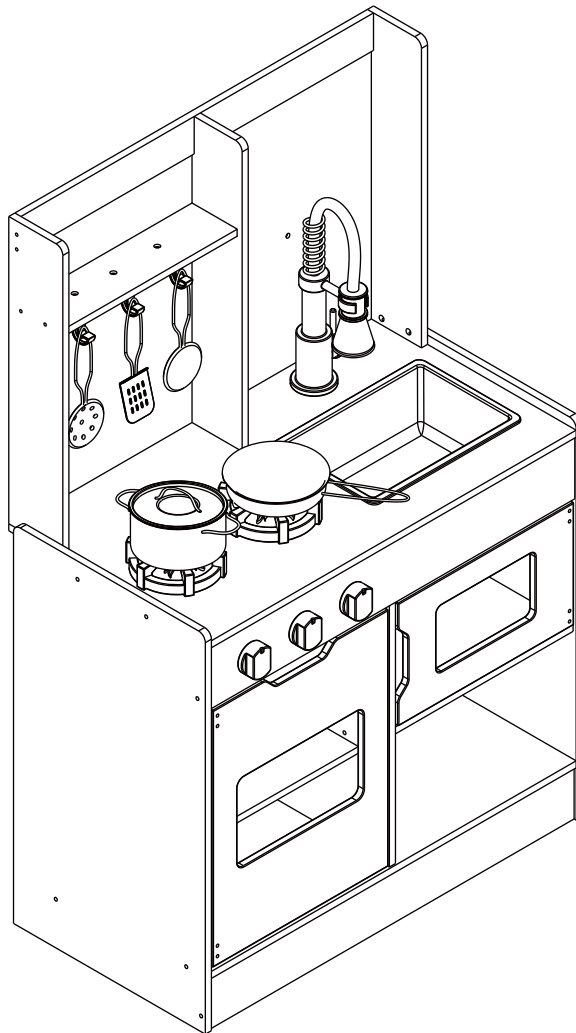

IN240701329V01_US_CA

350-185V80



WARNING

Must be assembled by an adult.



ATTENTION

Le jouet doit être assemblé par un adulte avant d'être utilisé.



EN: **WARNING:** Suitable for children of 3+ years old.

FR: **ATTENTION:** Convient aux enfants de 3+ ans.



EN IMPORTANT, RETAIN FOR FUTURE REFERENCE: READ CAREFULLY.

FR IMPORTANT : A LIRE ATTENTIVEMENT ET A CONSERVER POUR VOUS Y REFERER ULTERIEUREMENT.

WARNING:

1. CHOKING HAZARD—Small parts. Not for children under 3 years.
2. Only allowed for adults to install, keep children away.
3. To be used under the direct supervision of an adult.
4. Place it on a flat and clean floor, Check all the parts are well connected before use.

MAINTENANCE & CARE

- A. Keep all instructions and parts relating to this product for future reference.
- B. Please wipe down with a dry or damp cloth.

BATTERY WARNING:

- Non-rechargeable batteries are not to be recharged;
- Different types of batteries or new and used batteries are not to be mixed;
- Batteries are to be inserted with the correct polarity (+ and -);
- Exhausted batteries are to be removed from the toy;
- The supply terminals are not to be short-circuited.
- Do not mix alkaline, standard(carbon-zinc) or rechargeable (nickel-cadmium) batteries.
- Do not mix old and new batteries.

AVERTISSEMENT :

1. RISQUE D'ÉTOUFFEMENT - Petites pièces. Déconseillé aux enfants de moins de 3 ans.
2. Installation par des adultes uniquement, tenir les enfants à l'écart.
3. À utiliser sous la surveillance directe d'un adulte.
4. Posez-le sur un sol plat et propre. Vérifiez que toutes les pièces sont bien connectées avant toute utilisation.

ENTRETIEN ET MAINTENANCE

- A. Conservez toutes les instructions et les pièces relatives à ce produit pour pouvoir vous y référer ultérieurement.
- B. Veuillez essuyer avec un chiffon sec ou humide.

AVIS RELATIF AUX PILES :

- Les piles non rechargeables ne doivent pas être rechargées ;
- Ne pas mélanger différents types de piles ou des piles neuves avec celle usagées ;
- Les piles doivent être insérées en respectant la polarité (+ et -) ;
- Les piles épuisées doivent être retirées du jouet ;
- Les bornes d'alimentation ne doivent pas être court-circuitées.
- Ne pas mélanger les piles alcalines, standard (carbone-zinc) ou rechargeables (nickel-cadmium).
- Ne mélangez jamais des piles anciennes avec de nouvelles piles.

WARNING

- **INGESTION HAZARD:** This product contains a button cell or coin battery.
- **DEATH** or serious injury can occur if ingested.
- A swallowed button cell or coin battery can cause **Internal Chemical Burns** in as little as **2** hours.
- **KEEP** new and used batteries **OUT OF REACH** of **CHILDREN**
- **Seek immediate medical attention** if a battery is suspected to be swallowed or inserted inside any part of the body.











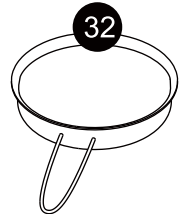
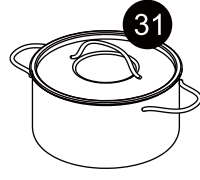
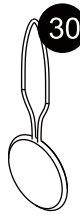
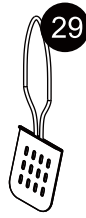
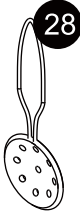
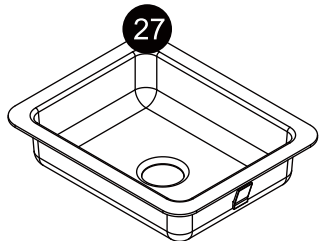
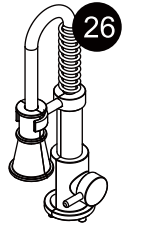
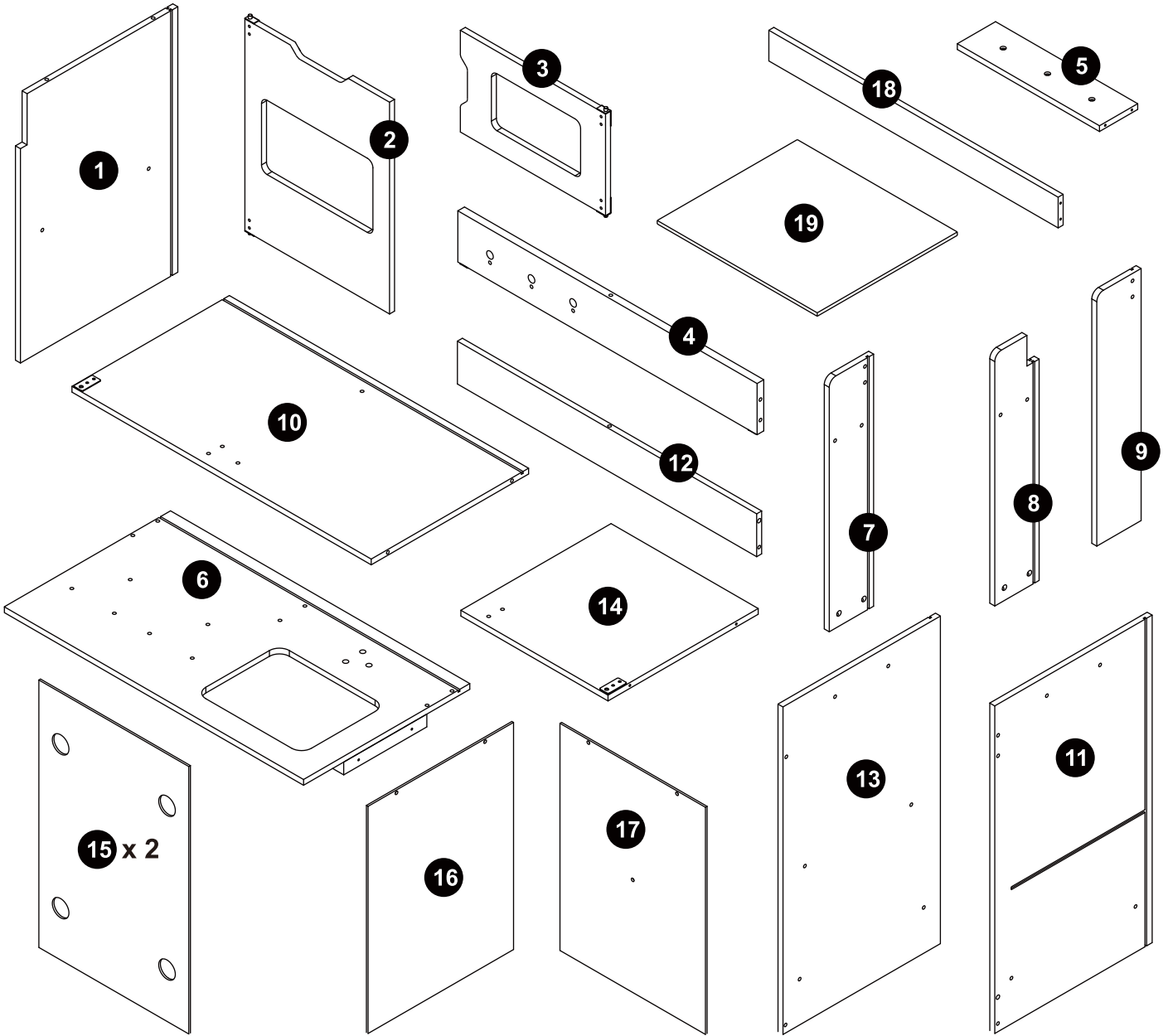



Battery Information

- 1) Battery type: LR44
- 2) Nominal Voltage: 1.5V

Warning

- a) Remove and immediately recycle or dispose of used batteries according to local regulations and keep away from children. Do NOT dispose of batteries in household trash or incinerate.
- b) Even used batteries may cause severe injury or death.
- c) Call a local poison control center for treatment information.
- d) The battery type:LR44
- e) Nominal battery voltage: 1.5V
- f) Non-rechargeable batteries are not to be recharged.
- g) Do not force discharge, recharge, disassemble, heat above (manufacturer's specified temperature rating) or incinerate. Doing so may result in injury due to venting, leakage or explosion resulting in chemical burns."
- h) Ensure the batteries are installed correctly according to polarity (+ and -).
- i) Do not mix old and new batteries, different brands or types of batteries, such as alkaline, carbon-zinc, or rechargeable batteries.
- j) Remove and immediately recycle or dispose of batteries from equipment not used for an extended period of time according to local regulations.
- k) Always completely secure the battery compartment. If the battery compartment does not close securely, stop using the product, remove the batteries, and keep them away from children.

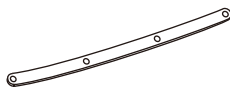
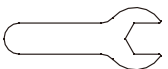

A	x 1	B	x 1	C	x 1	D	x 1	E	x 4
									
13 mm				35 mm				7 mm	
F	x 3	G	+1(spare) x 9	H	+1(spare) x 16	I	+1(spare) x 16	J	+1(spare) x 8
									
20 mm		9 mm		40 mm		25 mm			
				H -----Steel x8		I -----Steel x2			
				H* -----White x8		I* -----White x14			
K	x 2	L	x 1	M	x 1		x 1		
									

01

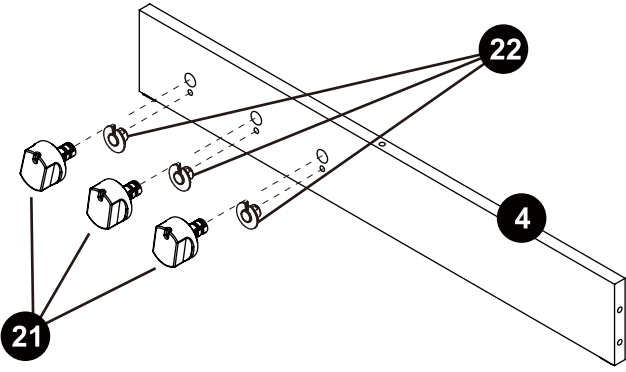

02

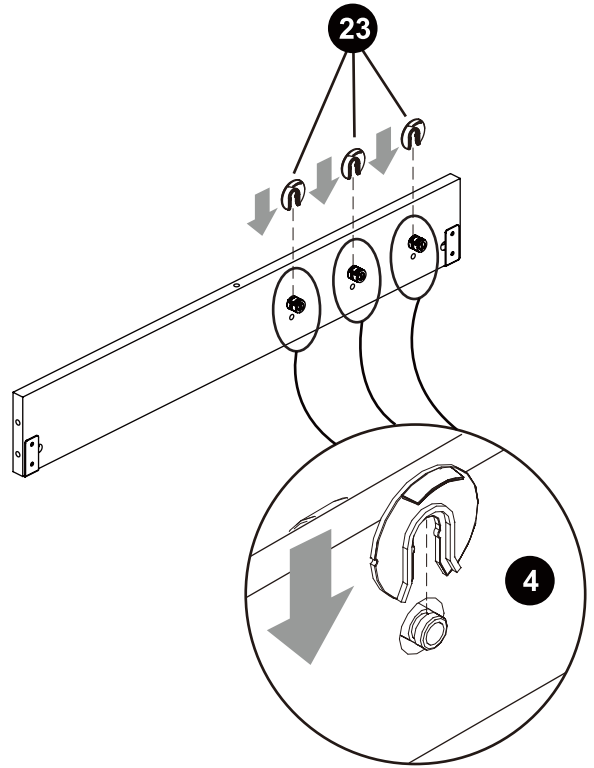

Fx3

03

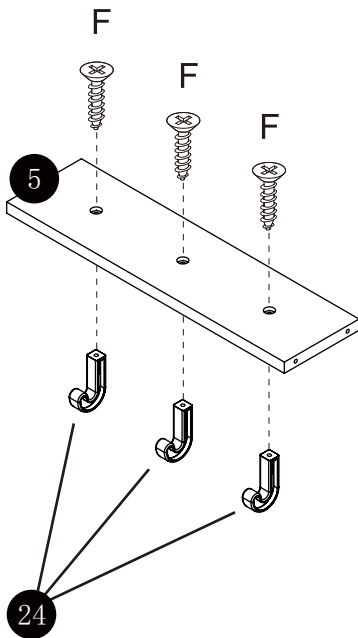

04

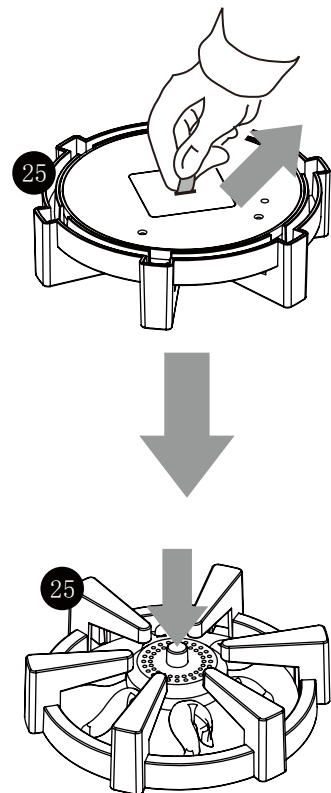

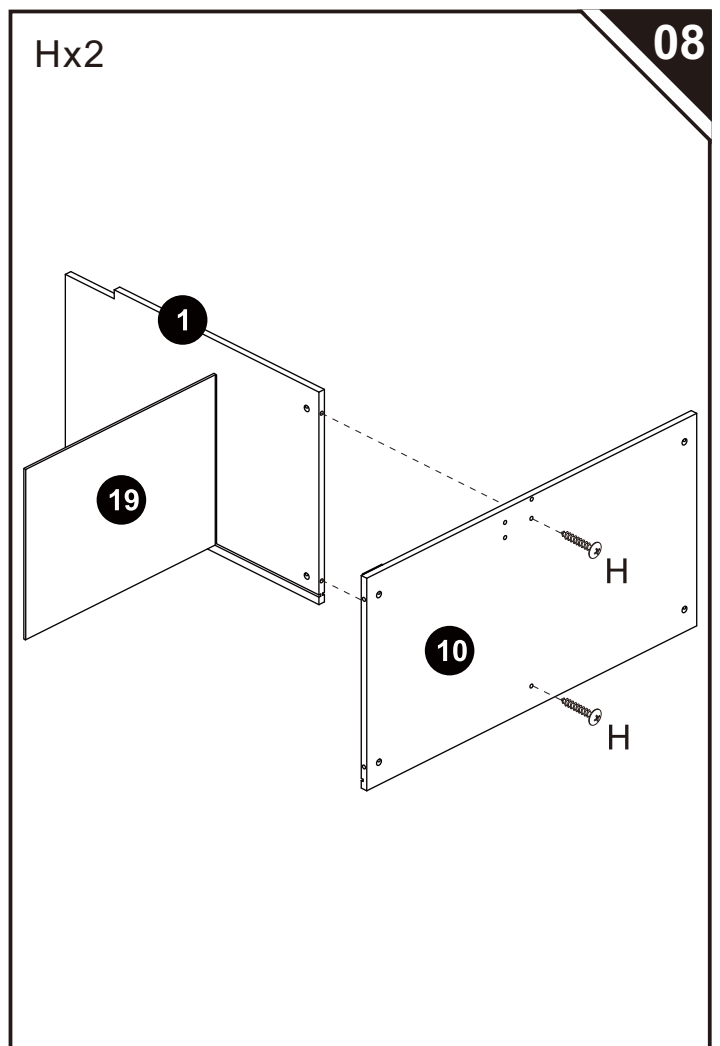
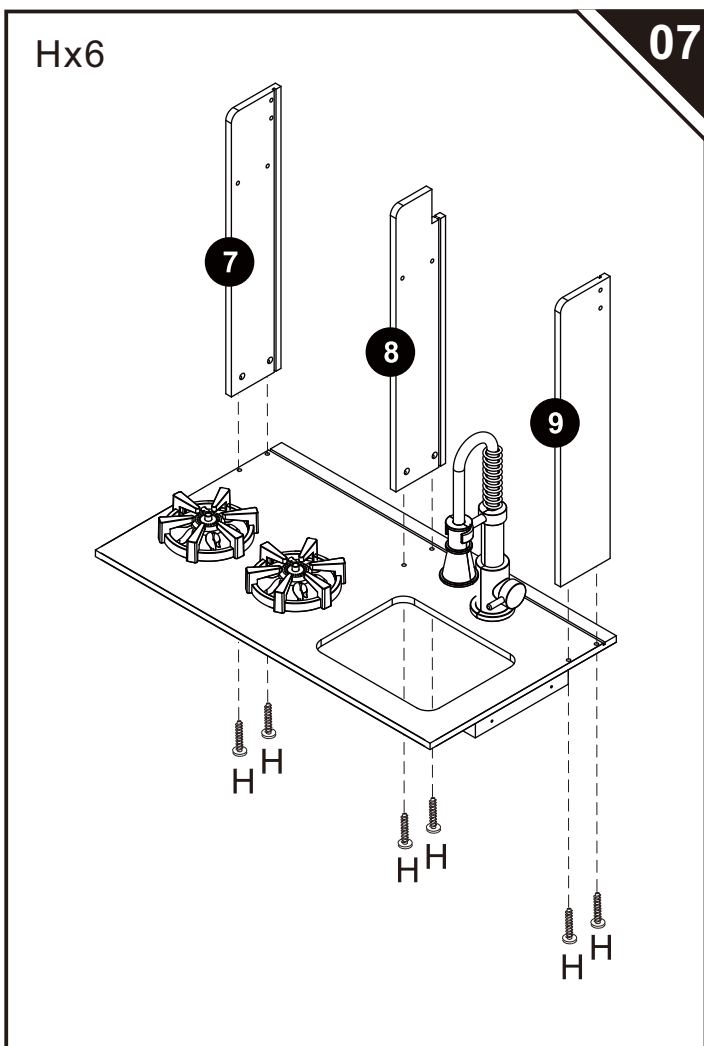
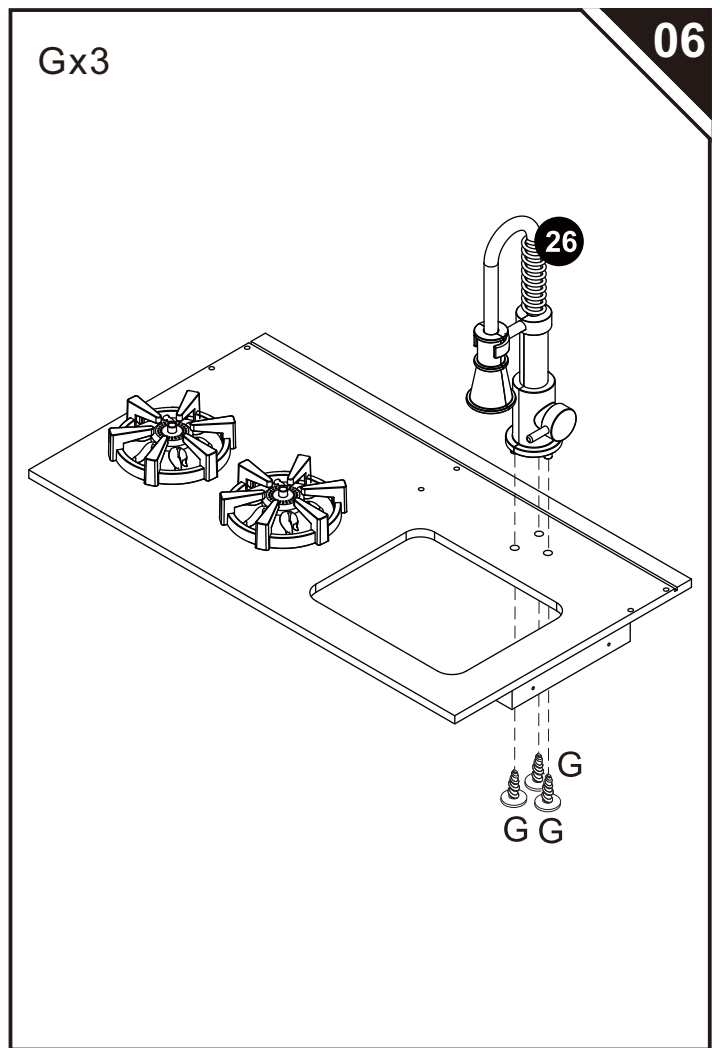
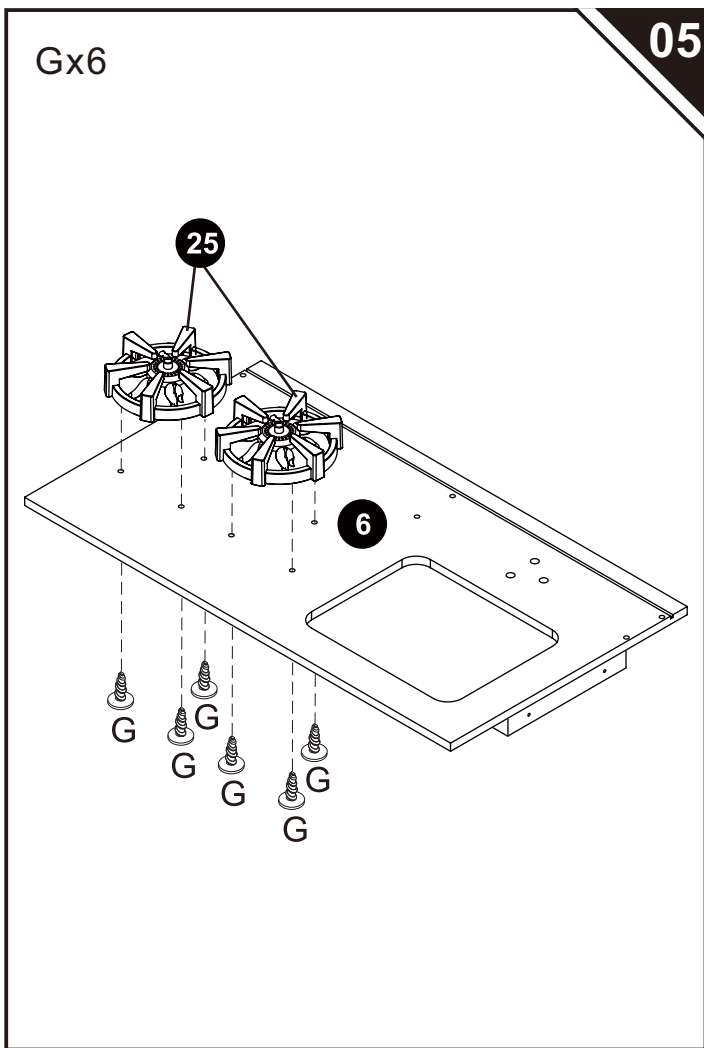

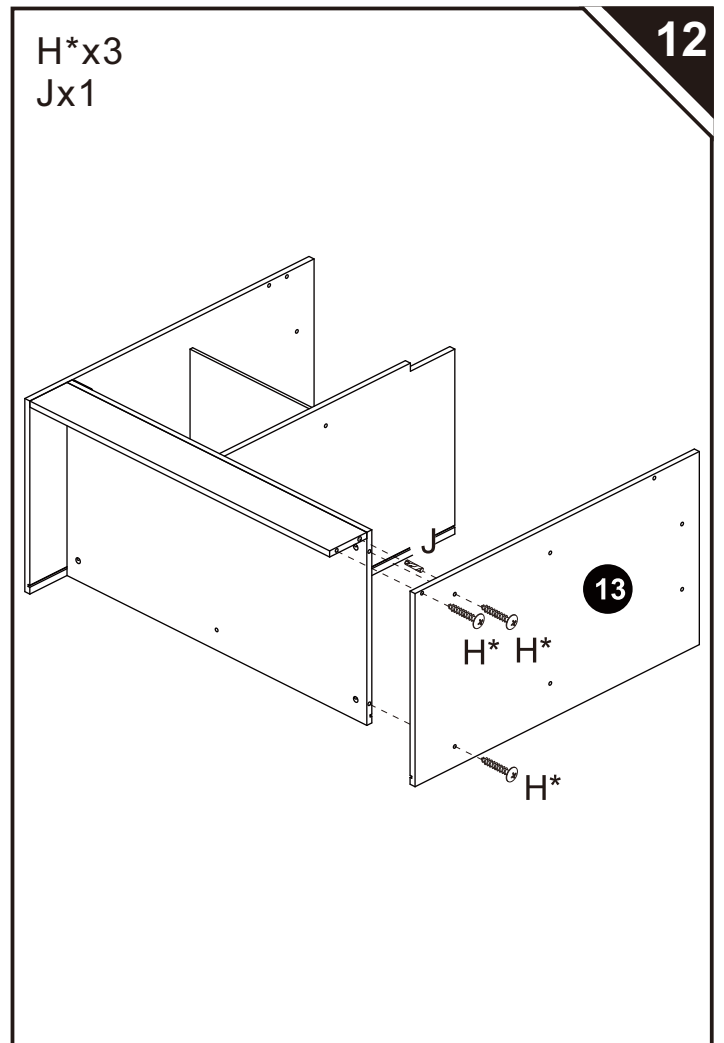
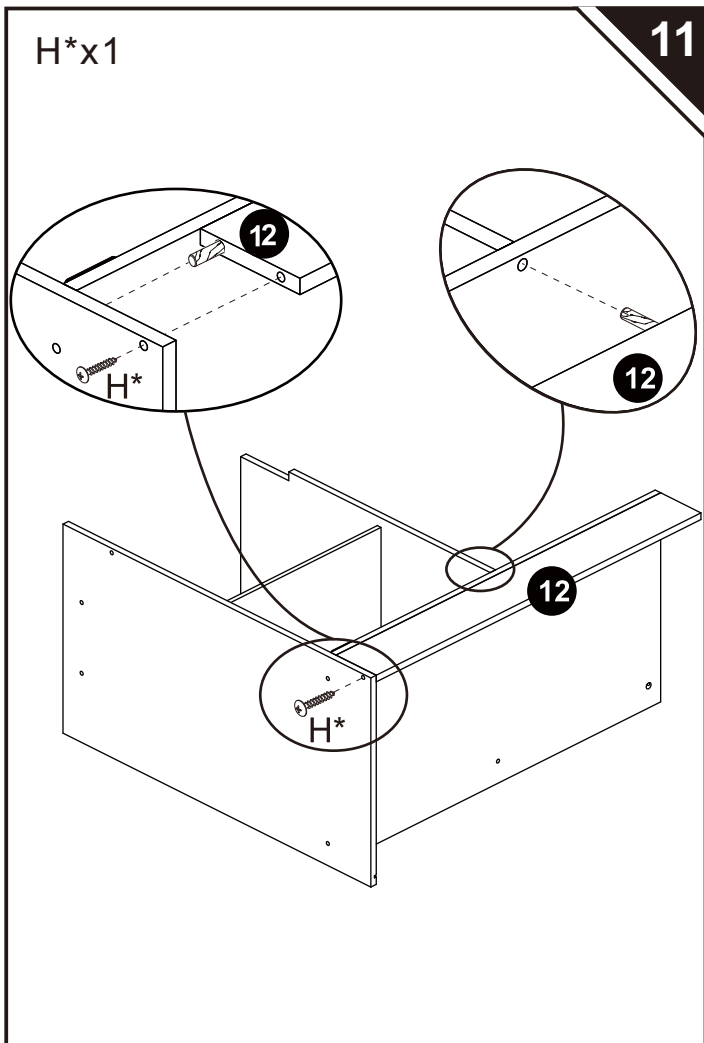
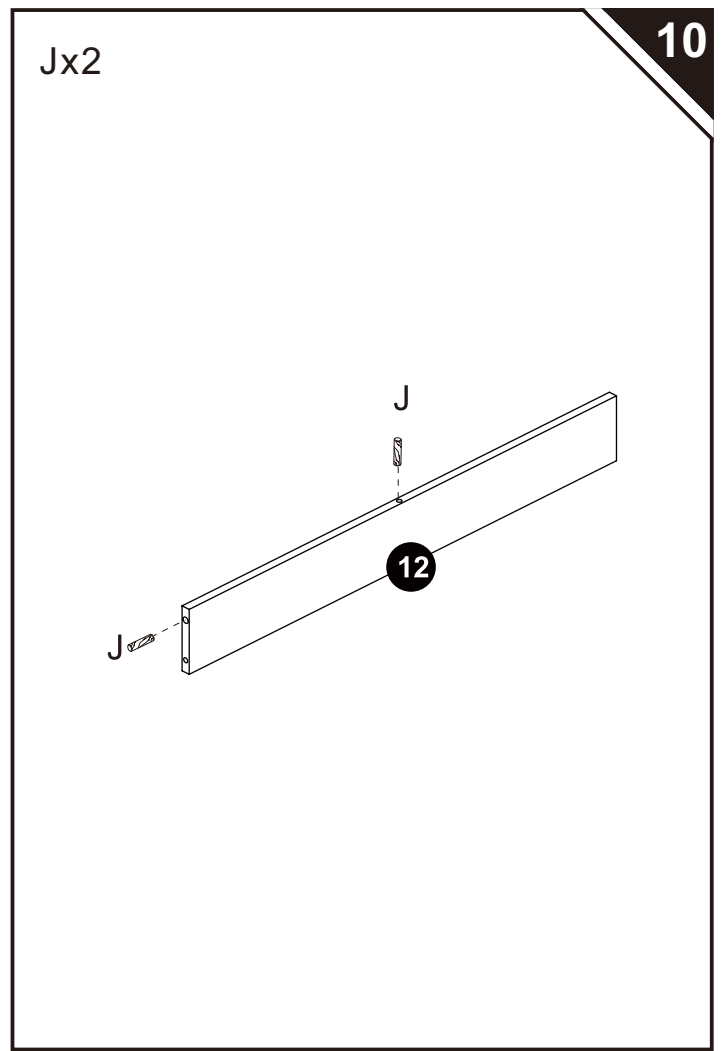
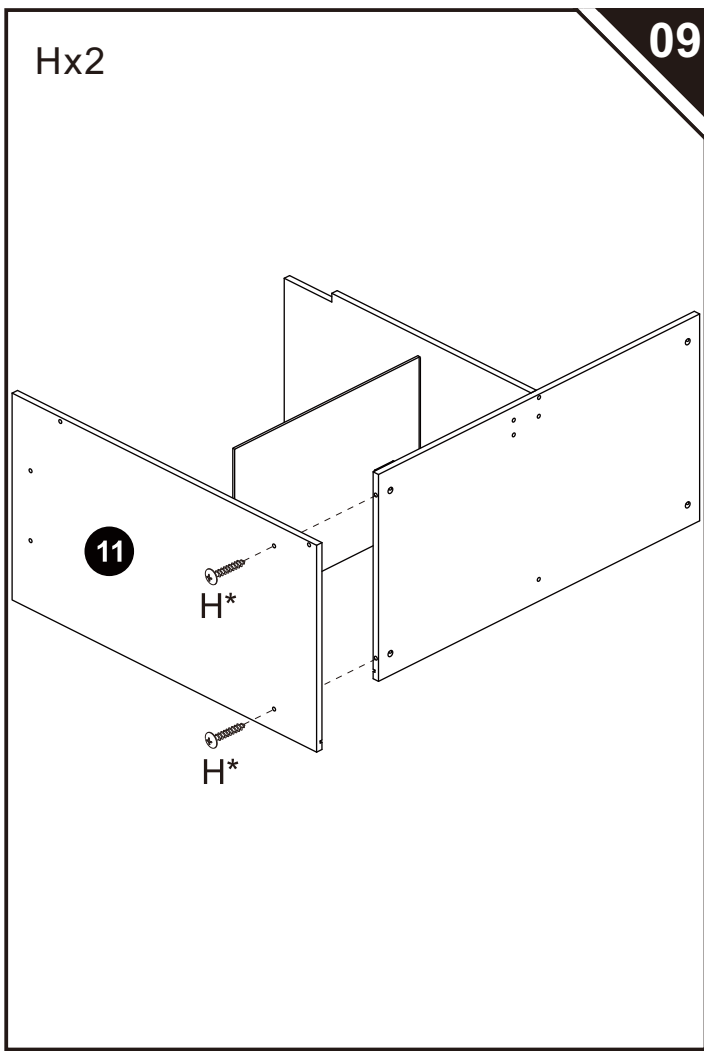

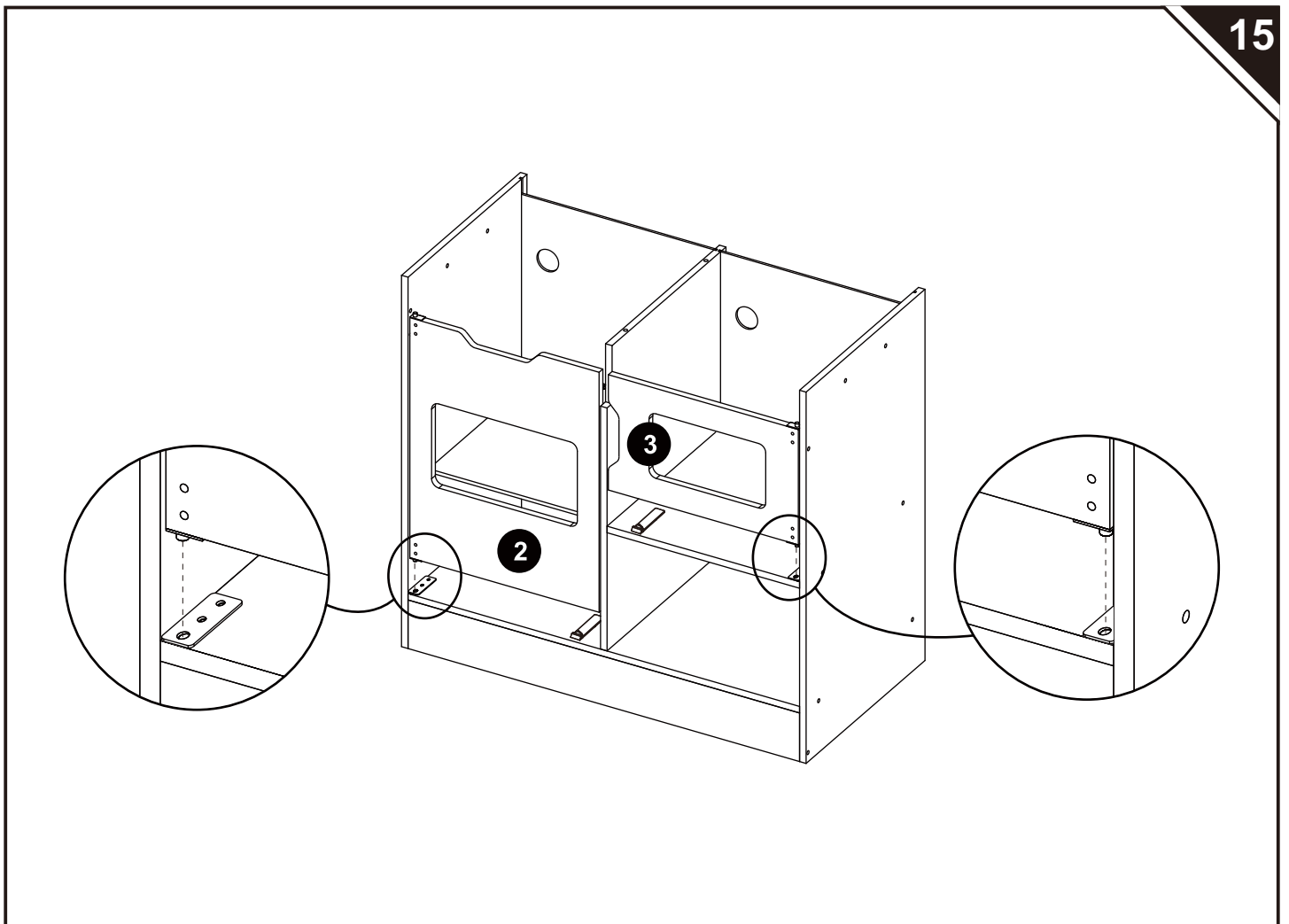
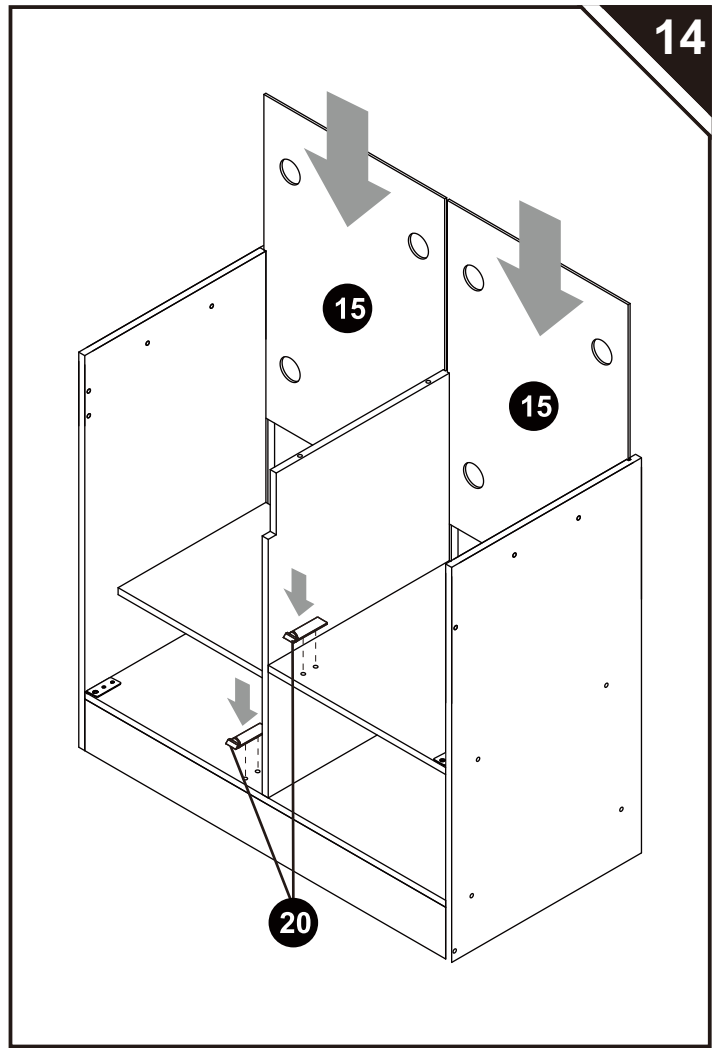
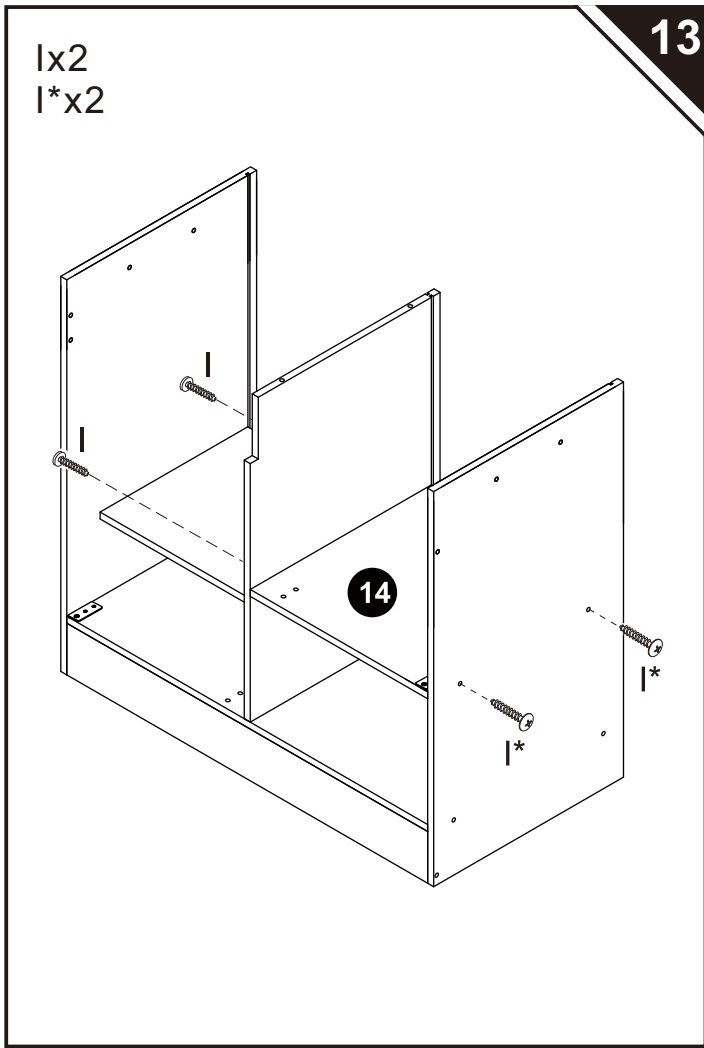

Jx2

16

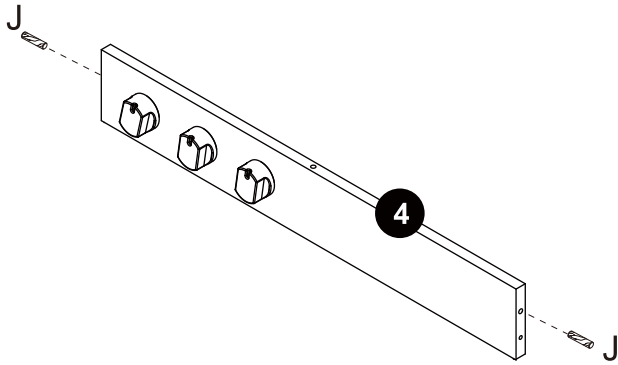

17

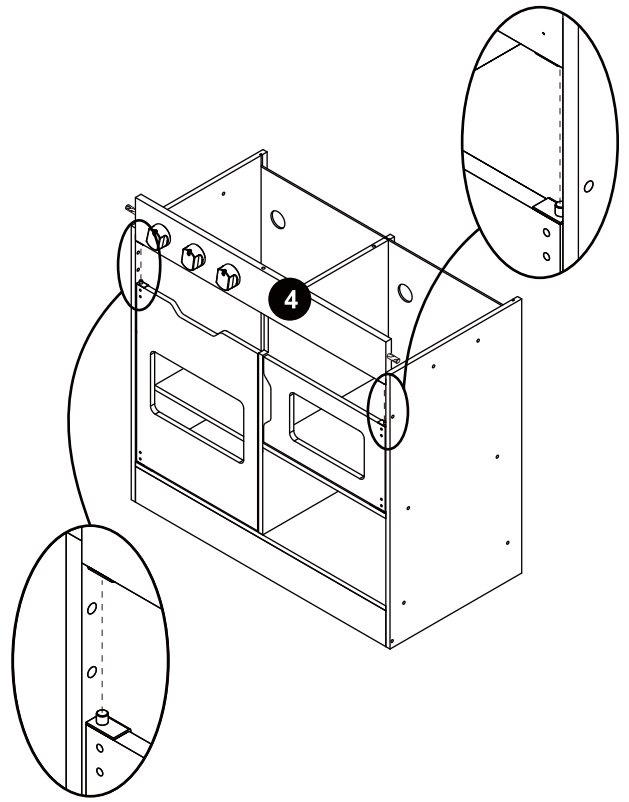

H*x2

18

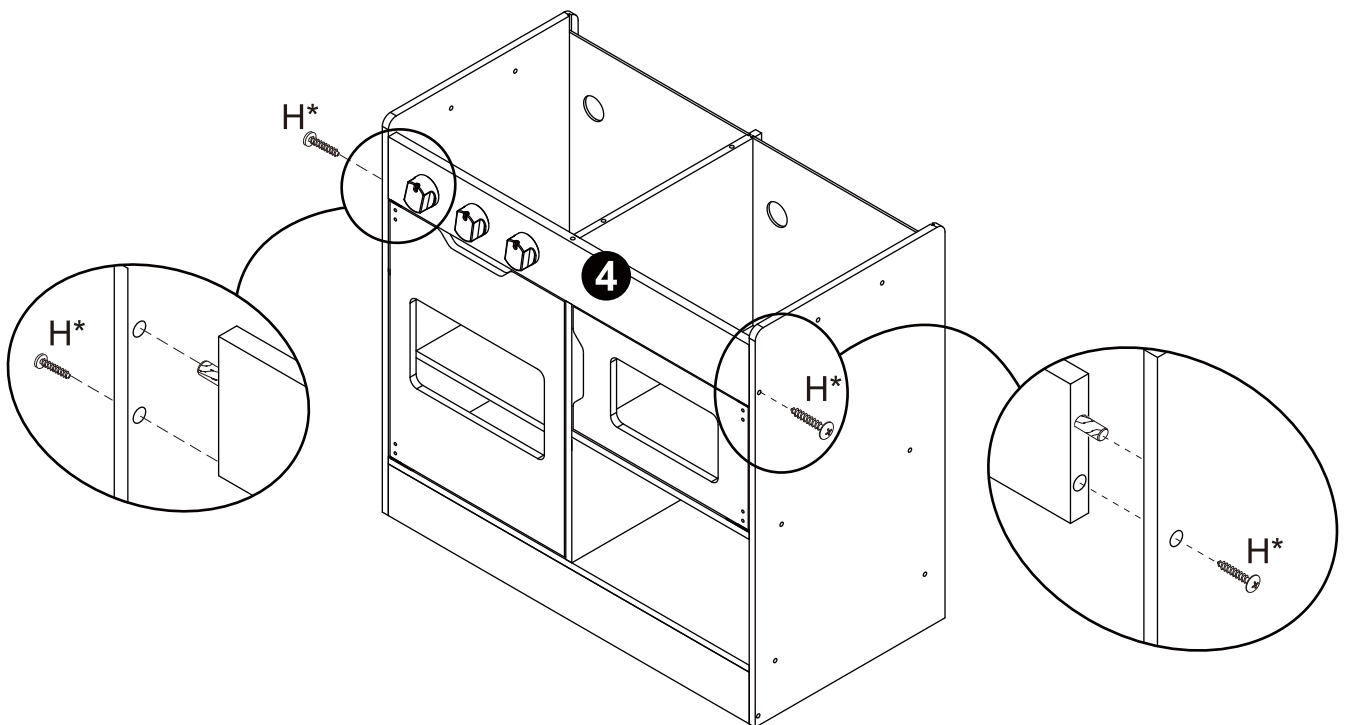

Jx3

19

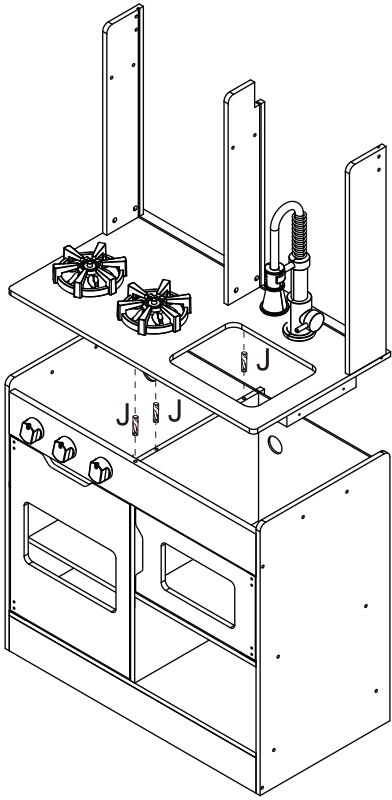

l*x4

20

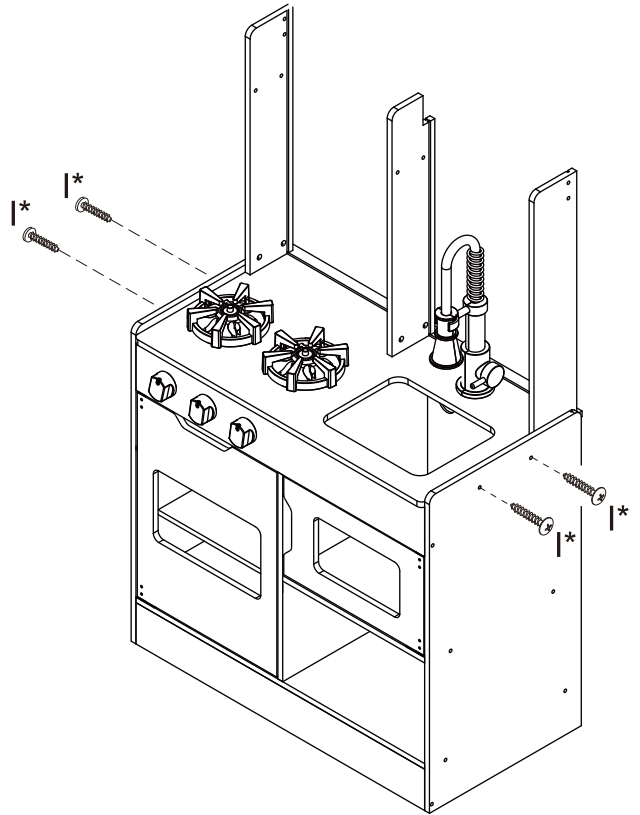

l*x4

21

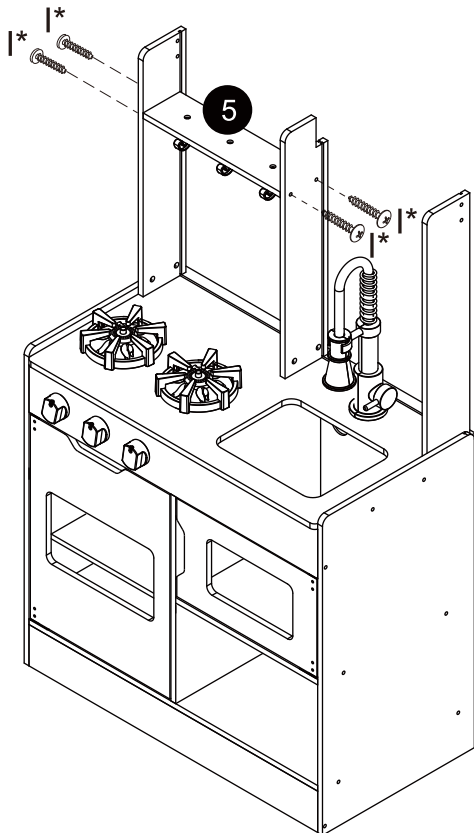

22

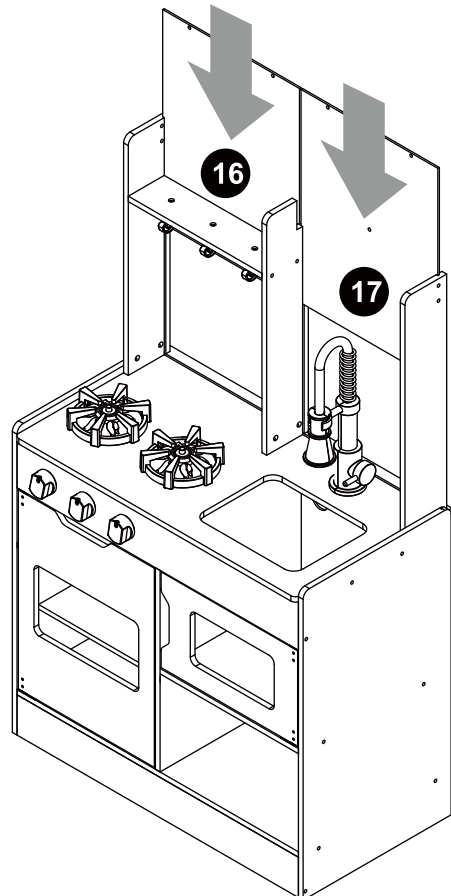

1*x4

23

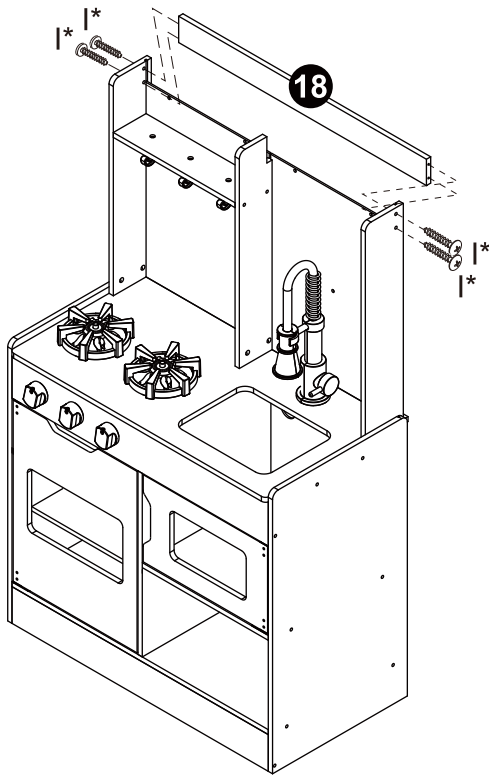

Ex4

24

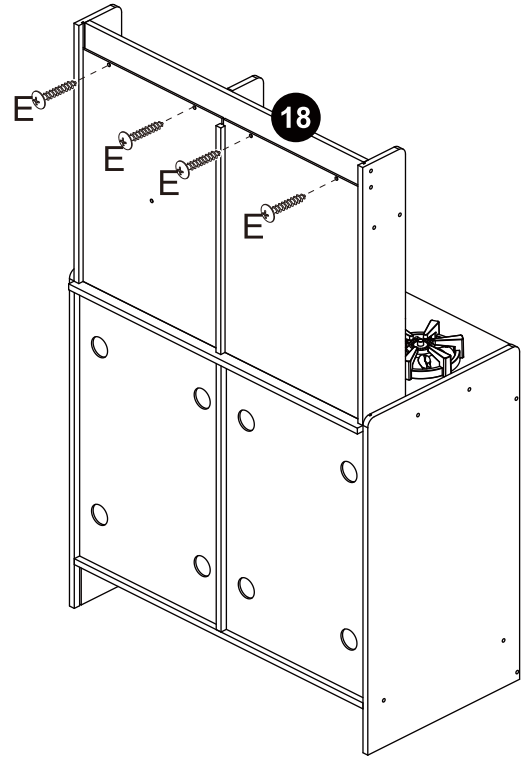

25

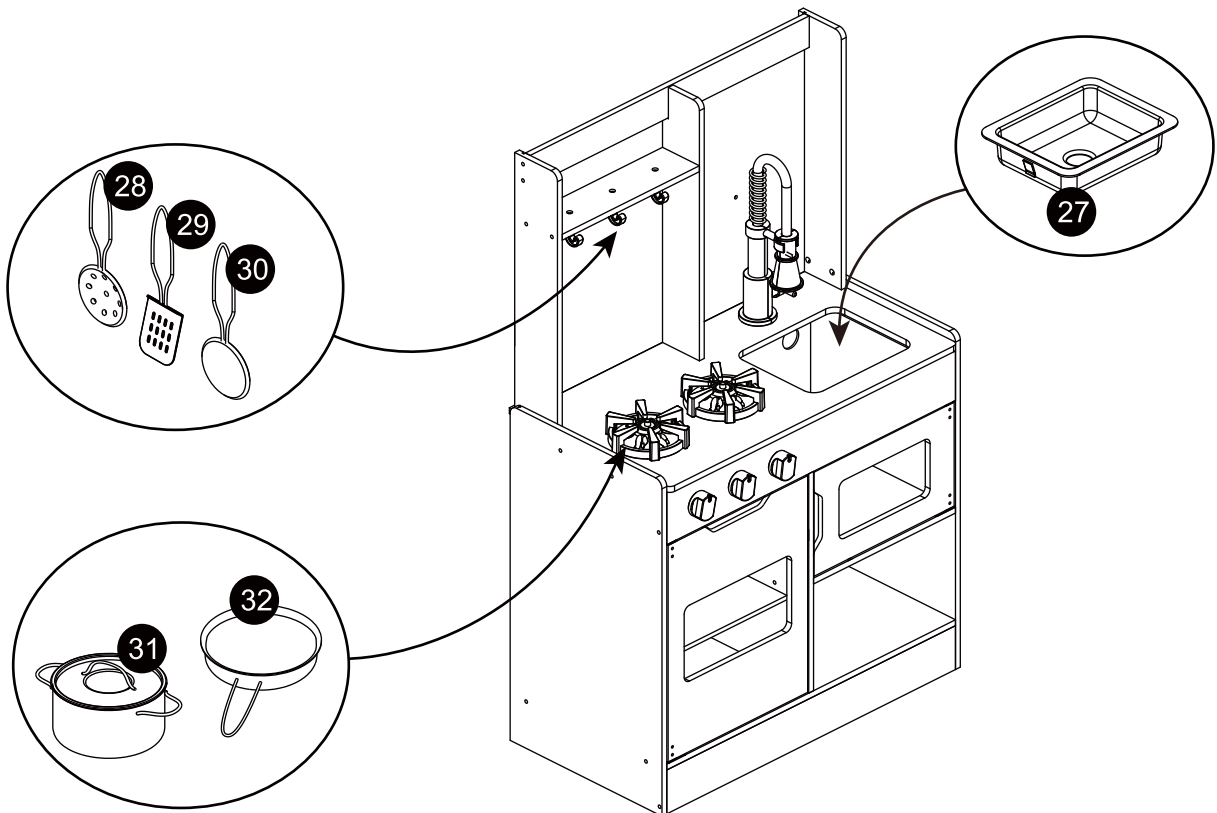

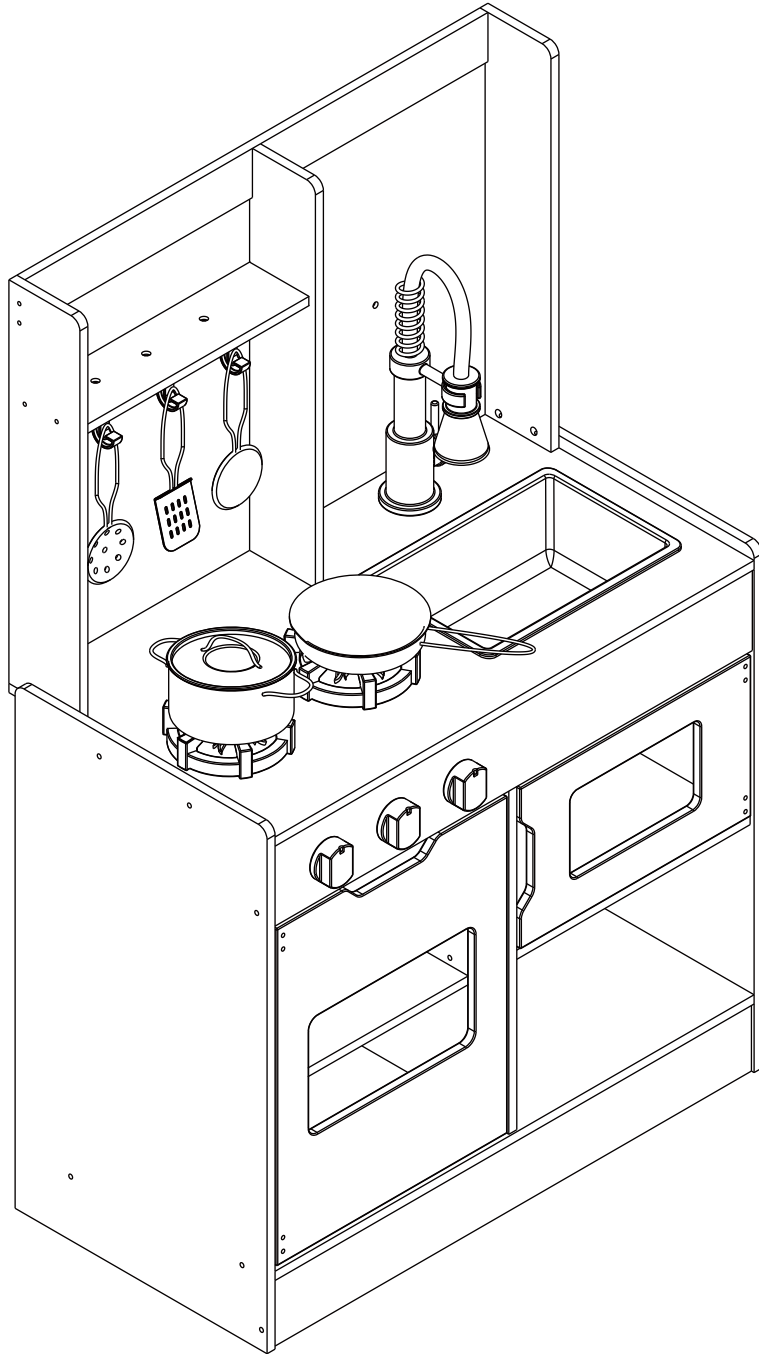

- Ax1
- Bx1
- Dx1
- Kx1
- Mx1
- Nx1

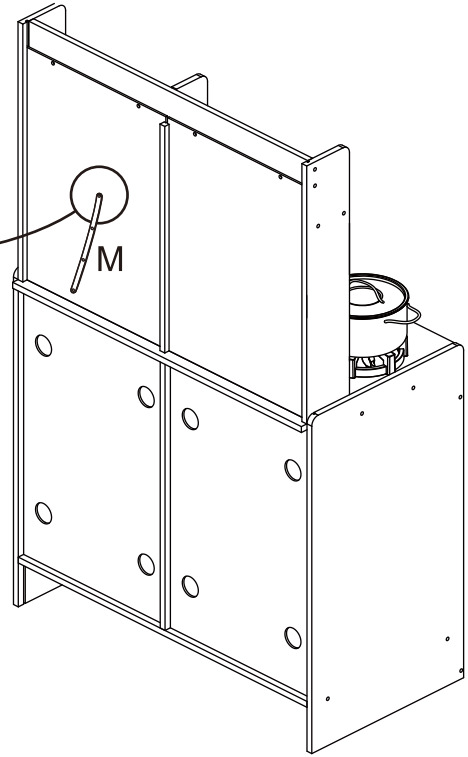
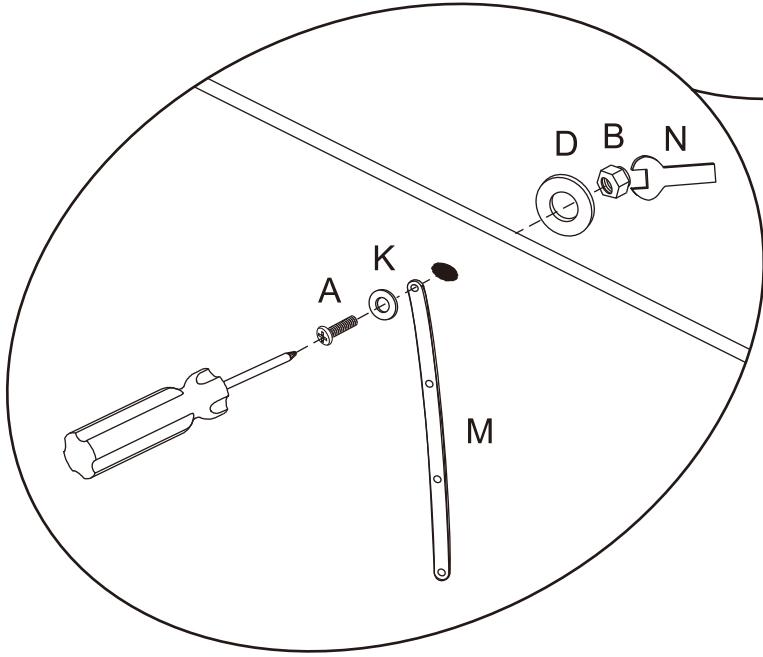

- Cx1
- Kx1
- Lx1

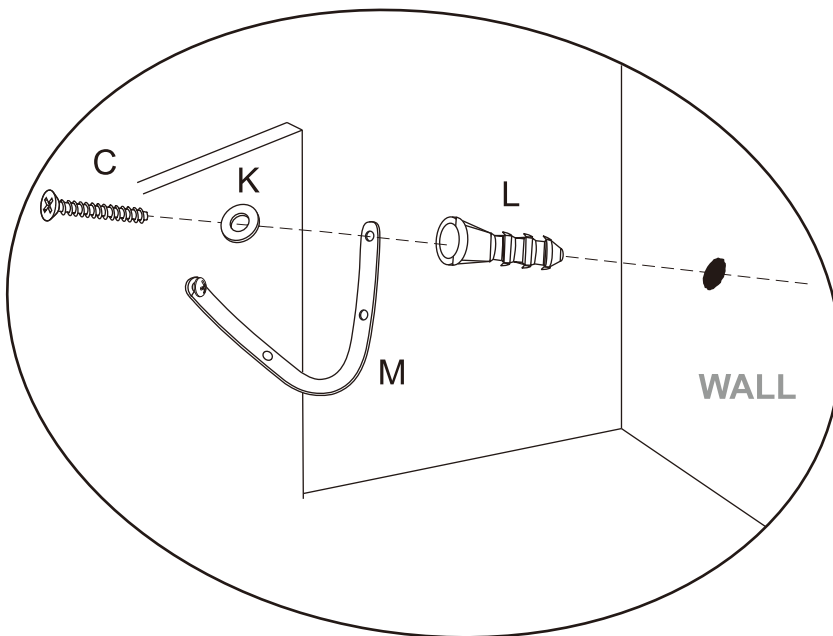

A1

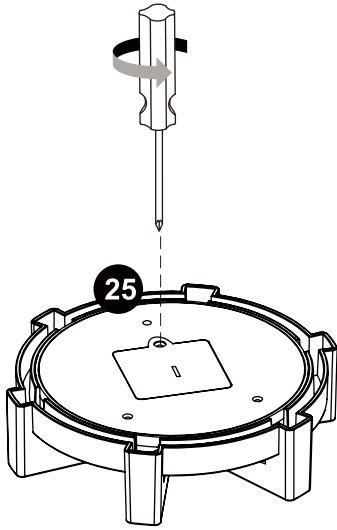

A2

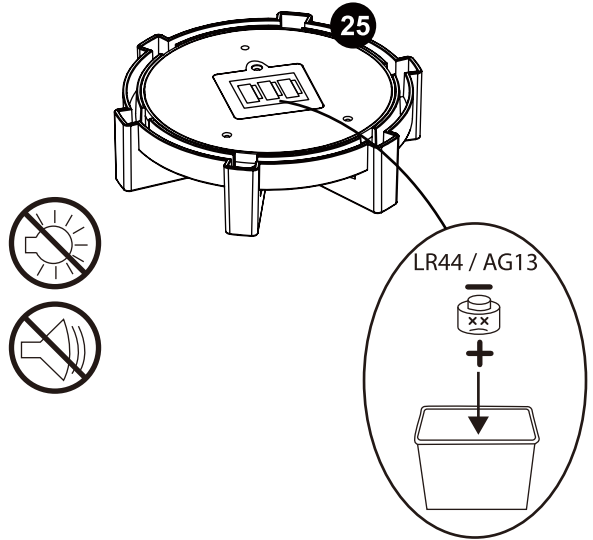

A3

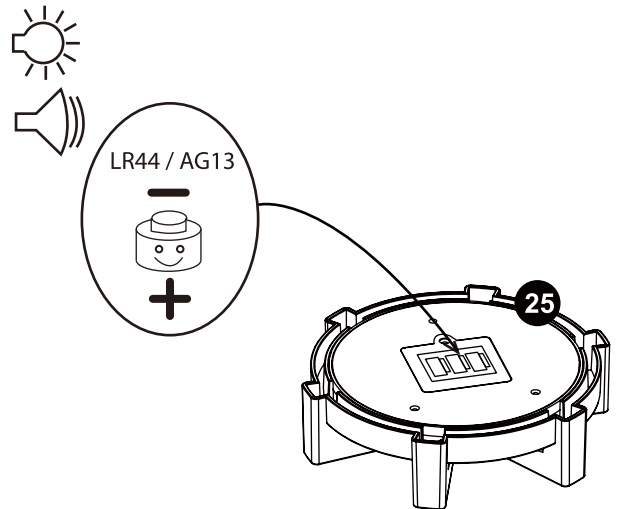
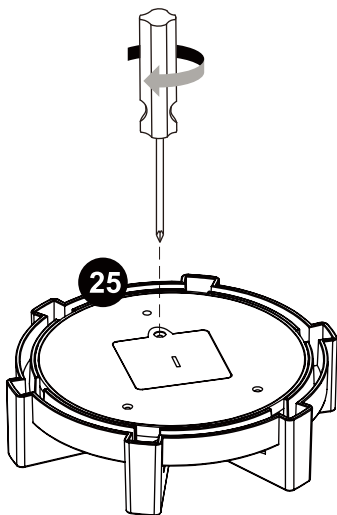

US

If you have any questions, please contact our customer care center.
Our contact details are below:



001-877-644-9366



customerservice@aosom.com

Imported by Aosom LLC
27150 SW Kinsman Rd Wilsonville, OR 97070 USA
MADE IN CHINA

CA

If you have any questions, please contact our customer care center.
Our contact details are below:

Si vous avez la moindre question, veuillez contacter notre centre d'assistance à la clientèle.
Nos coordonnées sont les suivantes:



416-792-6088



customerservice@aosom.ca

Imported by Aosom Canada Inc.
7270 Woodbine Avenue, Unit 307, Markham, Ontario Canada
L3R 4B9
MADE IN CHINA

Importé par Aosom Canada Inc.
7270 Woodbine Avenue, unité 307, Markham, Ontario Canada
L3R 4B9
FABRIQUÉ EN CHINE

