

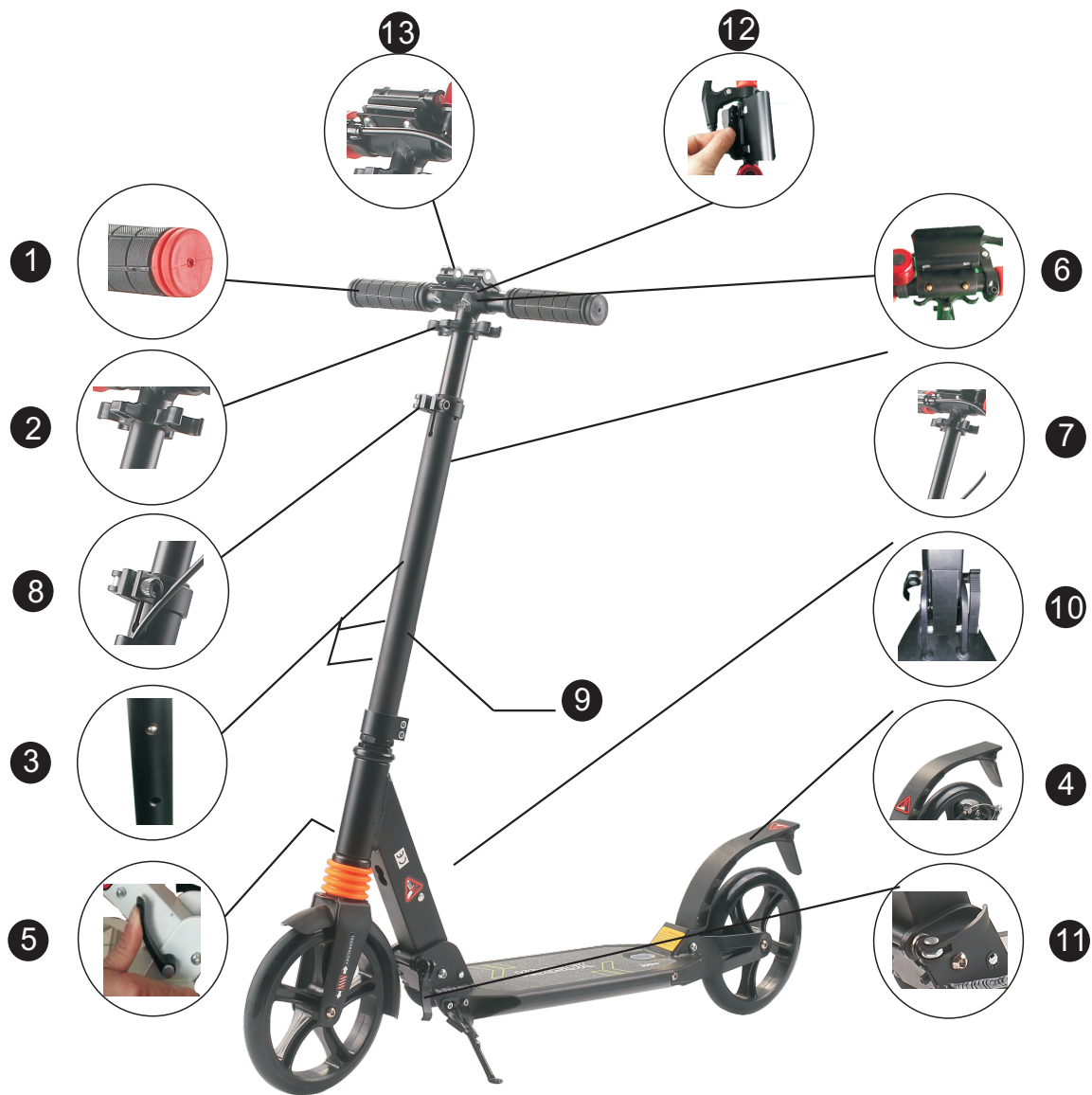

Scooter Operational Instructions

READ AND SAVE THIS INSTRUCTION FOR FUTURE USE

ASSEMBLY INSTRUCTION



1. Handles
2. Rapid tightening lever for handles
3. Steering column spring button
4. Brake/Mudguard
5. Locking lever for folding mechanism
6. Handle spring button
7. Handlebar stem
8. Rapid tightening lever for steering column
9. Steering column
10. Folding mechanism
11. Rapid tightening lever for folding mechanism
12. Plastic stopper
13. Handle locking mechanism

Your scooter is easy to handle and practical and can be used Anywhere: fold it and store it in the blink of an eye. It is quick and green: you will help to protect the environment Without wasting any time.

Please read and understand the following assembly instructions to avoid all risks of accidents linked to the folding and unfolding operations of your scooter (e.g., getting your finger stuck).

SCOOTER ASSEMBLY



A Remove the plastic plug

With the tools in the accessory bag, remove the plastic stopper (12) so that the handles (1) can be inserted into Handle locking Mechanism (13).

B- Unfolding the steering column

Open the rapid tightening lever (11) and push the locking Lever forward (5) to unlock the folding mechanism (10). Lift the steering column (9) until it reaches the Vertical locking position (you should hear a "click" if engagement correctly), then firmly tighten the rapid tightening Lever (11).

C- Positioning the handles

Take the two handles (1) out of their plastic cover, insert them into the right and left parts of the stem (7).

For each of the two handles, you should hear a "click", indicating that the handles are engaged (1). Check the two spring buttons (6) are effectively out and visible.

For scooters with suspension, open the handle quick-release Lever (2) and follow the instructions below before tightening it firmly.

D- Adjusting the handlebar height

Open the steering column rapid tightening lever (8), adjust the height of the handlebars until you hear a "click", indicating engagement in one of the two indexed positions, then firmly tighten the steering column rapid Tightening lever (8)

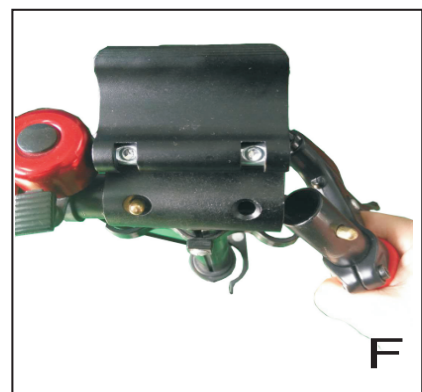

Folding the scooter

E-Folding down the handlebars

Open the steering column rapid tightening lever (8), press in the Steering column spring button (3), lower the handlebars, then tighten the steering column rapid tightening lever (8).

F- Packing away the handles

For each handle (1), press in the spring button (6), take the Handle out (1) from its place in the stem (7), and put it in its Plastic cover.

G- Folding the steering column

Open the rapid tightening lever (11), then push the locking lever Towards the front (5) to unlock the folding mechanism (10). It will be easier to unlock if you push the steering column Forwards (9). Then lower the steering column (9) until you reach the locking position, then tighten the rapid tightening lever (11).

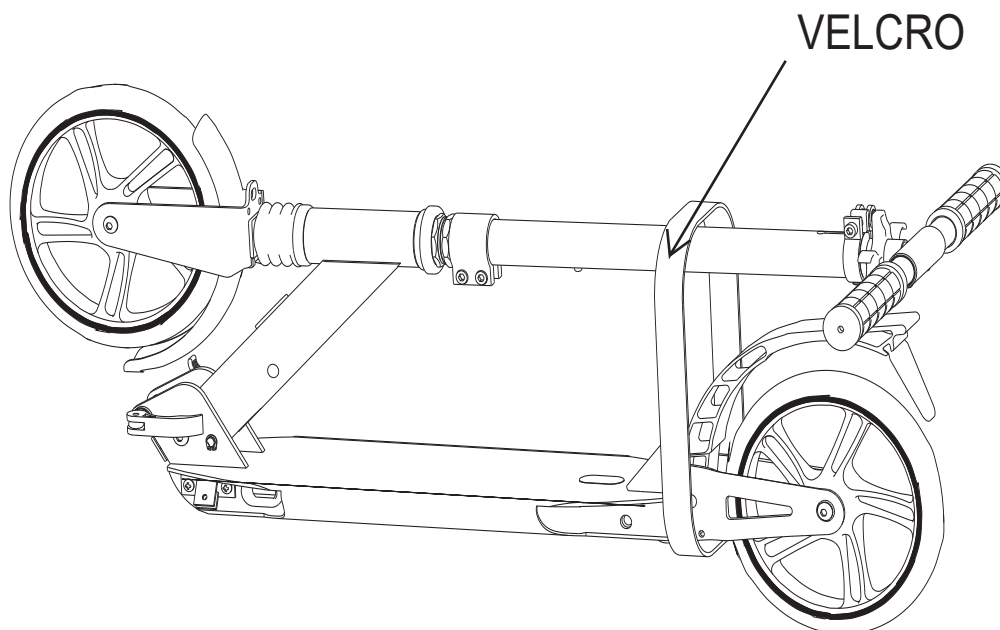

! **WARNING!** In order to prevent the stepping plate and the steering column from falling off when the product is strongly shaken or lifted, please connect the pedal and the steering column with the adhesive hook and loop tape according to the position in the picture after the product is folded.

Recommendations for use

Before each use, check that your scooter is correctly assembled:

There must be a “click “at each moment of Engagement in the vertical locking position of the steering column, and rapid tightening of the steering column and of the folding mechanism. **Please note:** the brake may become hot during use. Do not touch

Advice for use

This product is not a toy; it is for sport and fun.

To brake: use your pushing foot to press on the brake. As most serious accidents take place during the initial month, please take the time to learn the basics of the sport. For the safety, we advise you to use this scooter with protective equipment: helmet, elbow pads, knee pads and gloves. The maximum weight of the user is 100kg (220Lbs). This scooter is designed for use by one person at any one time. Respect the current Highway Code. Avoid places with heavy traffic or that are too busy.

- ◆ Avoid slippery or wet surfaces.
- ◆ Avoid steep slopes and ensure that the brake is in good working order.
- ◆ Always wear shoes (for example: training shoes).
- ◆ Take care to always keep two hands on the handlebars.
- ◆ Do not change the purpose of this product. This scooter is not made for acrobatic use. Do not jump over obstacles.
- ◆ In all situations, take care both of yourself and others. You are advised not to use the scooter at night.

Maintenance

Regularly check that the various screwed parts are tight, particularly the wheel axles, the fold axis, the brake shaft, the head tube locking collar and suspension as the self-tightening screws or other attachments may lose their effectiveness.

Always replace used parts with original parts.

Remove any sharp fragments caused by use.

Keep the scooter in a dry, dust- free place.

Do not modify or transform the scooter, specifically the steering column and socket, the stem, the folding mechanism, and the back brake.



Check the condition of the bearings and wheels regularly and replace them if necessary.

US



001-877-644-9366
customerservice@aosom.com

CA



001-855-537-6088
customerservice@aosom.ca

UK



0044-800-240-4004
enquiries@mhstar.co.uk

DE



0049-(0)40-88307530
service@aosom.de

FR



0033-1-84166106
contact@aosom.fr

ES



0034-931294512
atencioncliente@aosom.es

IT



0039-0249471447
clienti@aosom.it