

Installation Manuals

A90-147
A90-148







Please read the manual carefully and follow the instructions for proper use.
After reading, please keep it in order to confirm at any time. Please be sure to attach the manual to ensure safety when transferring the product

- 1.Safety Precautions
- 2.Parts details
- 3.Installation steps
- 4.Folding storage
- 5.Maintenance and repair

Safety Precautions

Be sure to read and follow the safety warning instructions below
 If you feel unwell when using this product, stop using it immediately, consult your doctor and follow your doctor's instructions before using it.
 To ensure safety, please do not exceed 30 minutes a day. Please follow the instruction manual to avoid sports injury caused by improper posture.
 If you feel abnormal or uncomfortable during exercise, stop using it immediately to avoid possible injury.
 Do not use this product after drinking or eating to avoid discomfort or accident.
 This product should be placed in a suitable place, such as a flat and solid floor to avoid falling or injury.
 Wear suitable clothing during exercise to avoid injury or accident.
 The maximum service load shall not exceed 120KG.

Spare parts

1. The main frame is folded		2. Flexible pull pin	
3. Plum knob		4. digital watch	

Installation steps

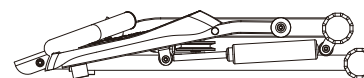

Step one

open the package, you can see

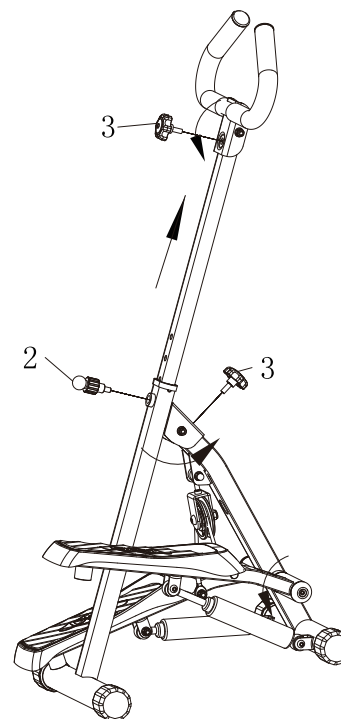

Step two

In the direction of the arrow, unfold the frame and insert it in the corresponding position (2-elastic pull pin) (3-Plum knob) Knob, and lock

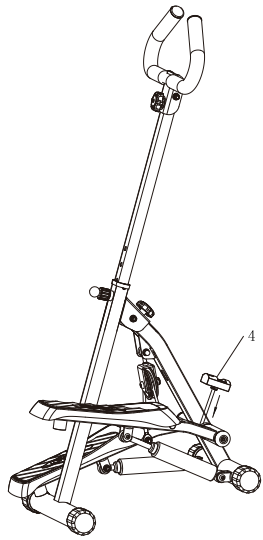

Step three

The (4–electronic form) installed in the direction of the arrow, that is assembled

Folding storage

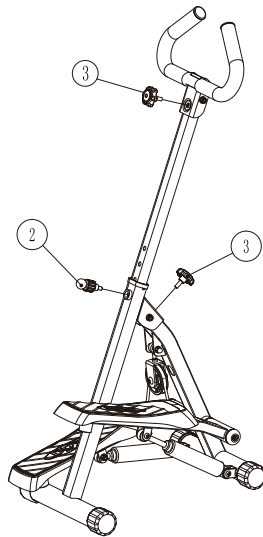

Step one

Write down the plum knob 3 and the pull pin knob 2 in turn

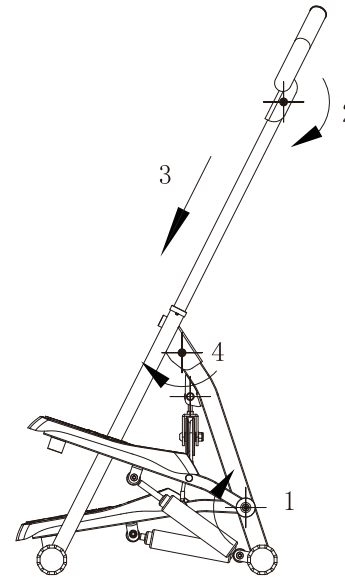

Step two

Follow the steps in the figure

1. Adjust the pedal angle
2. Rotary armrest assembly.
3. Telescopic handrail rod assembly.
4. Rotate the front support bracket and finally insert the pulley mounting bolts into the slots.

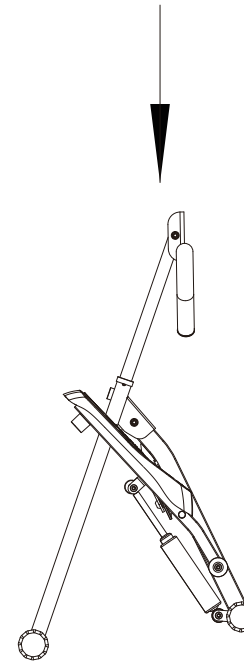

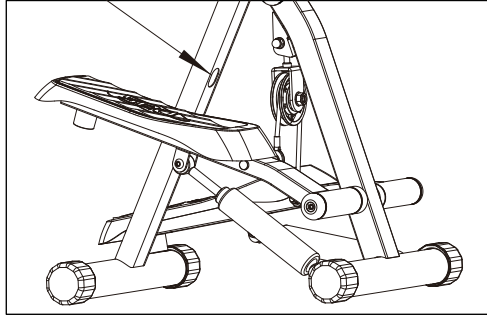

Step three

Place the head of the pulley fixing bolt into the front bracket slot

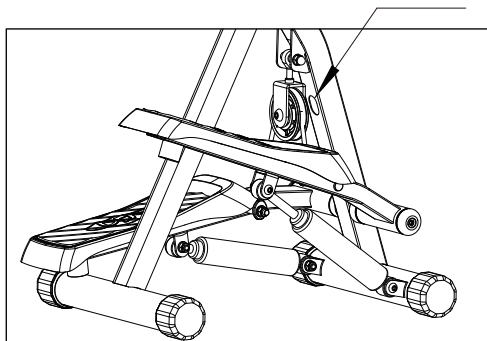

Step four

Place the tail of the pulley securing bolt into the rear bracket slot

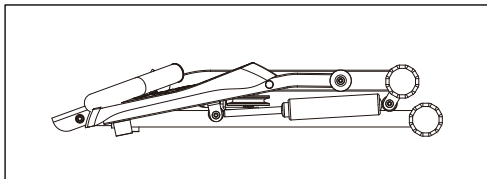

Step five

Completely folded renderings

Maintenance

Fold the main frame

After closing the product, please put the product in a fixed position, it is recommended to put it horizontally so as to avoid collisions and cause unexpected accidents.

Maintain

1. Available neutral detergent diluted with water to wipe the cloth carefully rub the grease, and then dry with a dry cloth.
2. Do not use alkaline cleaner, dilute solvent, volatile oil and other solvents.

Maintenance / inspection

1. Avoid high temperature, humidity or direct sunlight, please place in a well-ventilated and clean place.
2. Please fold it when not in use and keep it out of the reach of children.
3. If not used for a period of time, before exercise, be sure to confirm the precautions and the product for normal use and then use.
4. In the event of malfunction, abnormality or any operational problems, please contact us.