

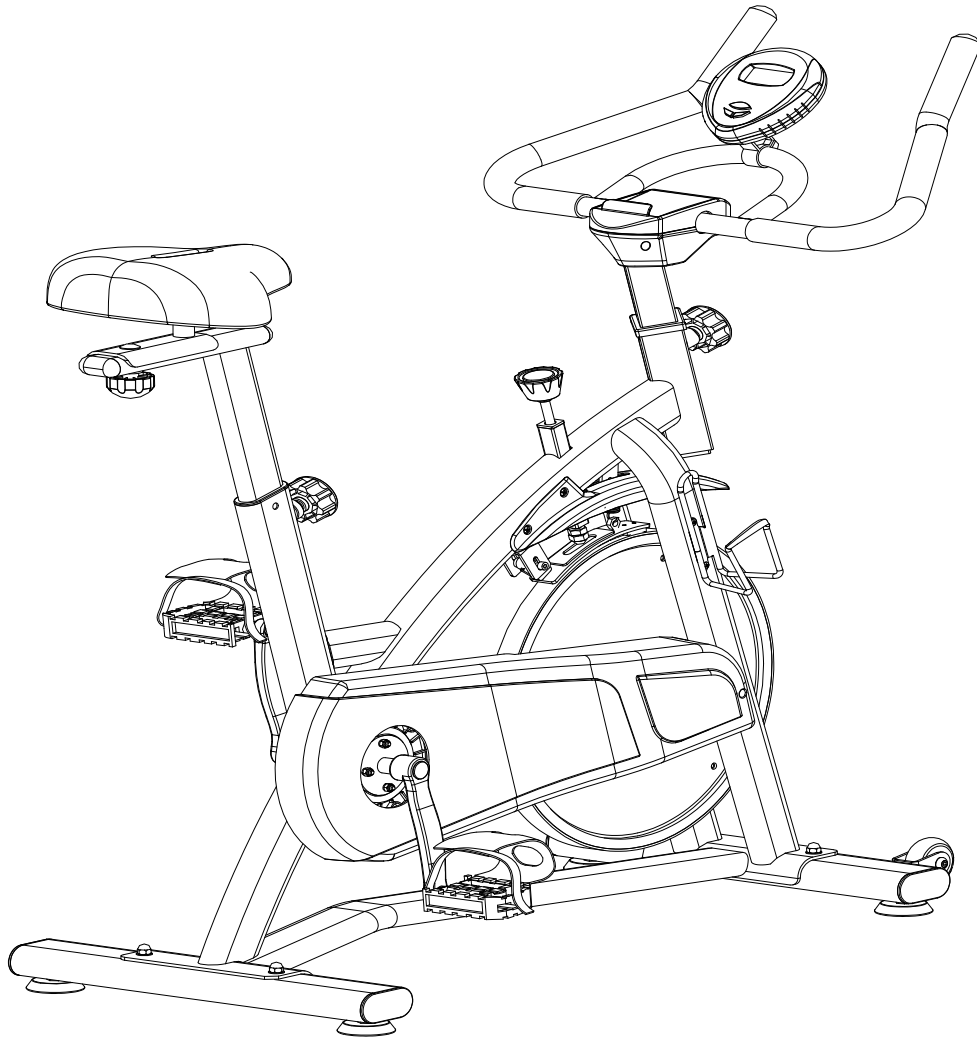

INada082V01_UK

A90-198



User Manual

READ AND SAVE THESE INSTRUCTIONS FOR FUTURE USE

ASSEMBLY INSTRUCTION

PRE-ASSEMBLY INSTRUCTIONS

GENERAL INSTRUCTIONS

Carefully read through the instructions contained in this manual. It provides you with important information about assembly, safety and use of the machine.

- 1 This unit has been designed for home use. The weight of the user must not exceed 275 lbs. (125 kg.)
- 2 Keep your hands well away from any of the moving parts.
- 3 Parents and/or those responsible for children should always take their curious nature into account and how this can often lead to hazardous situations and behavior resulting in accidents. Under no circumstances should this appliance be used as a toy.
- 4 The owner is responsible for ensuring that anyone who uses the machine is duly informed about the necessary precautions.
- 5 Your unit can only be used by one person at a time.
- 6 Use suitable clothing and footwear. Make sure all laces/cords are tied correctly.

IMPORTANT SAFETY ADVICE- PRECAUTIONS

This bike has been designed and constructed to provide maximum safety. Nevertheless, certain precautions should be taken when using exercise equipment. Read the whole manual before assembling and using the bike. The following safety precautions should also be observed:

1. Keep children or pets away from this equipment at all times. DO NOT leave them unsupervised in the room where this bike is kept.
2. This bike does not free-wheel. You can stop the bike immediately by pull up or push down the emergency break on the tension knob while you are exercising.
3. It can only be used by one person at a time.
4. If you experience dizziness, nausea, chest pains or any other symptom while using this appliance STOP the exercise. SEEK MEDICAL ATTENTION IMMEDIATELY!
5. Use the unit on a mat placed level, solid surface. Adjust the stabilizer for assure stability.
6. Keep your hands well away from any of the moving parts.
7. Wear clothing suitable for doing exercise. Do not use baggy clothing that might get caught up in the bike. Always wear running shoes or trainers when using the machine.

8. This appliance must only be used for the purposes described in this manual. DO NOT use accessories that are not recommended by the manufacturer.
9. Do not place sharp objects near the machine.
10. Disabled people should not use the machine without the assistance of a qualified person or a doctor.
11. Do warm up stretching exercises before using the equipment.
12. Do not use the bike if it is not working correctly.
13. Review all the warnings affixed to the machine and replace all the labels if damaged, illegible, or removed. You can obtain the labels from Parts & Service location.
14. Functional and visual inspections of the equipment shall be made after assembly is complete.
15. Don't exceed this MAX mark when you're adjusting the handlebar post or seat post.
16. Spinning pedals can cause injury. Pedal speed should be reduced in a controlled manner.
17. Before using the bike, thoroughly inspect the bike for proper assembly.
18. A parameter distance of 3 feet / 1meter is required before operating the unit.
19. User must adjust the seat and handlebars to the user's height requirements. Please be sure the adjustment knob is locked tight and seat and handlebars are secure.
20. Do not ride the bike in a standing position.
21. The bike should only be used for the home. Not meant for commercial use.
22. Before every use please examine brake pads for signs of wear. Brake pads are susceptible to damage and should be replaced over time.
23. This bike is not suitable for therapeutic use. Consult a physician prior to starting an exercise program.
24. This bike should only be used after a through review of the operation manual and the warning label.

Caution: Consult your doctor before beginning to use the bike. This advice is especially important for those over 35 or suffering from health problems. Read all of the instructions before using any exercise equipment.

EXPLODED VIEW

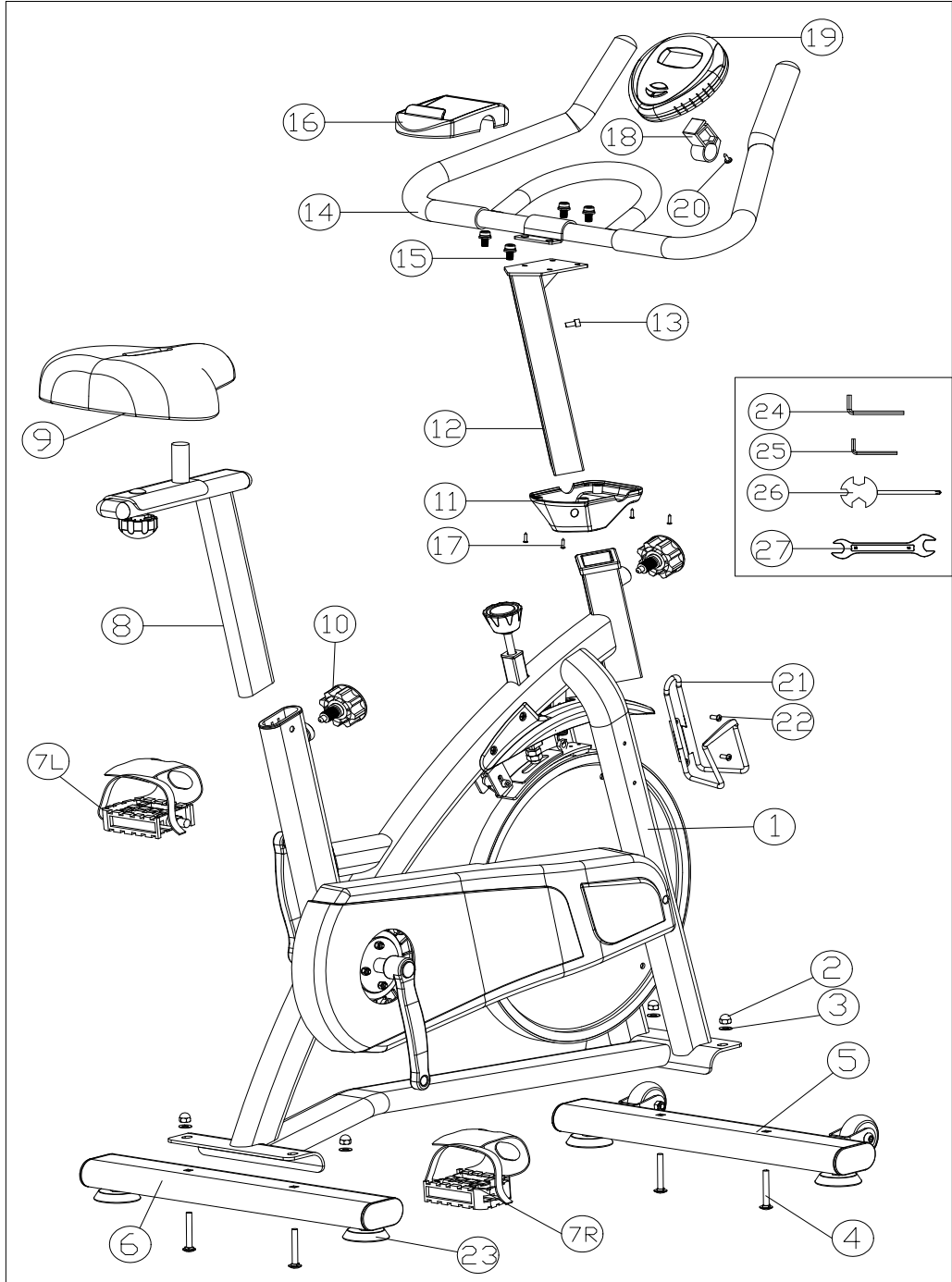

PART LIST

Part number	Description	Quantity
01	Main frame	1
02	Nuts	4
03	washer	4
04	bolts	4
05	Front Stabilizer	1
06	Rear Stabilizer	1
07	pedal L/R	1
08	Seat post	1
09	Seat	1
10	Knob	2
11	Lower phone cover	1
12	Handle bar supporter	1
13	Limit screw	1
14	Handlebar	1
15	Combination screw	4
16	Upper phone cover	1
17	Cover screws	4
18	Monitor holder	1
19	Monitor	1
20	Self-tapping screw	1
21	Bottle holder	1
22	Bottle holder screws	2
23	Adjust mat	4
24	Allen wrench	1
25	Allen wrench	1
26	screwdriver	1
27	13-15 wrench	1

ASSEMBLY INSTRUCTIONS

STEP 1

Fasten the front stabilizer (5) and rear stabilizer (6) on the frame (1) with 2 sets of bolt (4), washer (3) and cap nut (2).

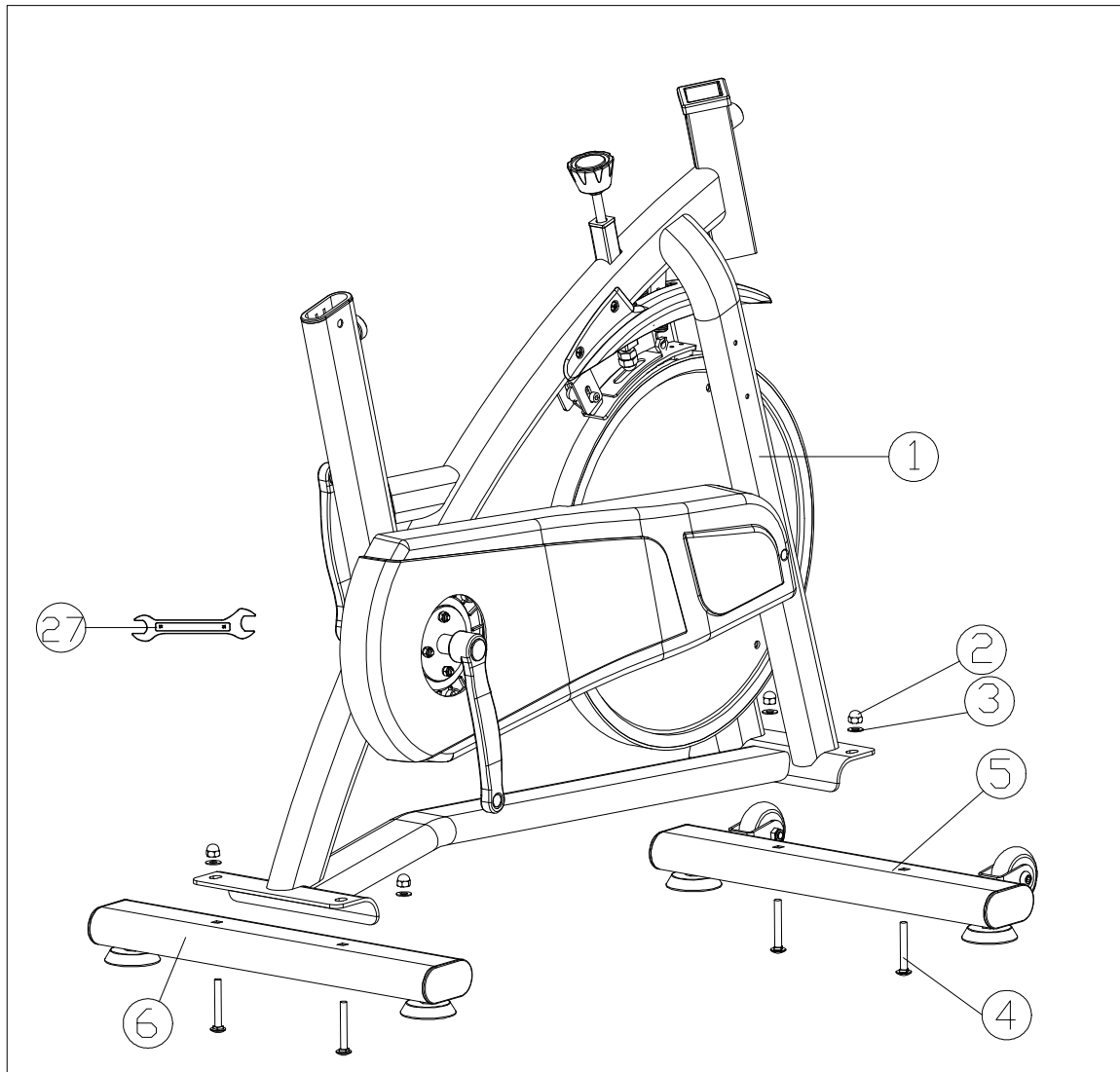

STEP 2

Fasten the front Get the Seat post (8) and inserted into the frame (1) and tightened with a knob(10). and then put the seat (9) onto the seat post and screwed with a wrench(27).

At last , Remove the pedal (7) and screw the foot pedal L into the left crank of the main frame (1), and the foot pedal R is screwed into the right crank.

note:

The right foot is installed clockwise

Left foot installation is counterclockwise

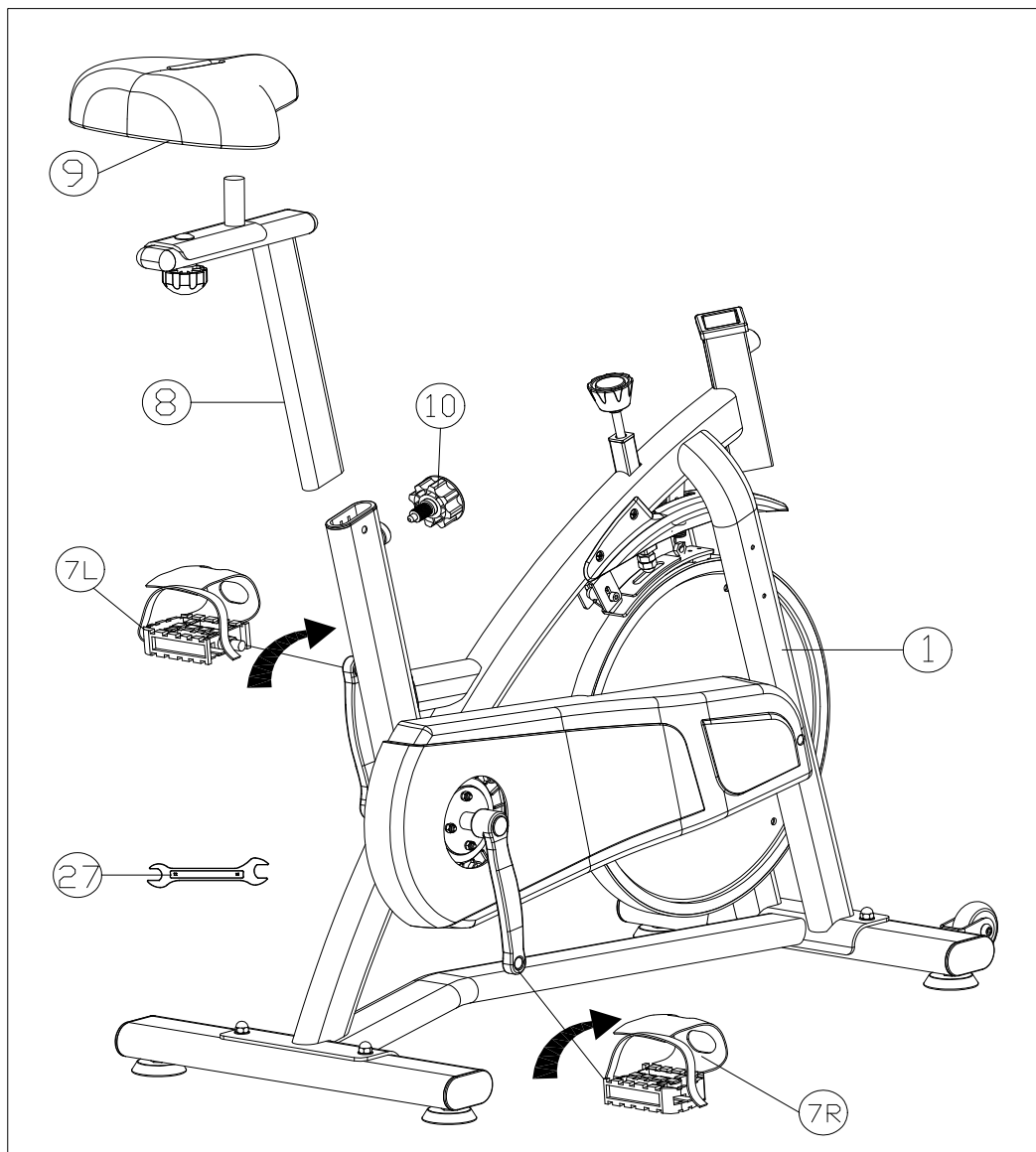

STEP 3

First , get the handle bar supporter(12) together with lower phone cover(11) inseted into the frame and the knob to tighten , then use the Allen wrench (25) to lock the upper limit screw (13) .

Second ,remove the handle (14) and secure the handle bar to the Handle bar supporter(12)with the combination screw (15) and the wrench (24).

Last , take out the upper phone cover (16) and let the upper phone cover and lower phone cover together , and then use the screwdriver (26) to lock the cover screw (17).

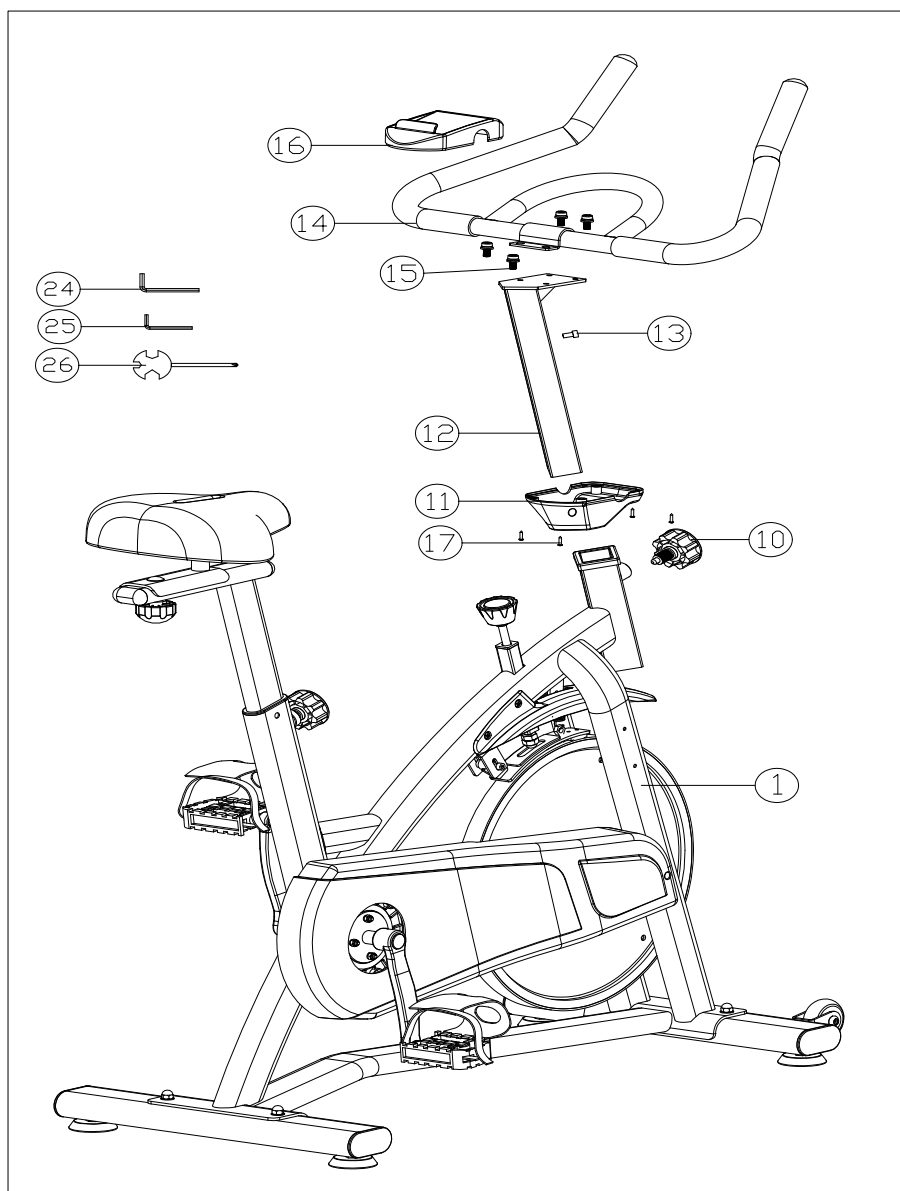

STEP 4

Remove the monitor holder (18) and attach it to the handlebar (14). Then the monitor (19) is stuck on the monitor holder, use the screwdriver to tighten the self-tapping screw, and connect the sensor cable.

At last, lock the bottle holder

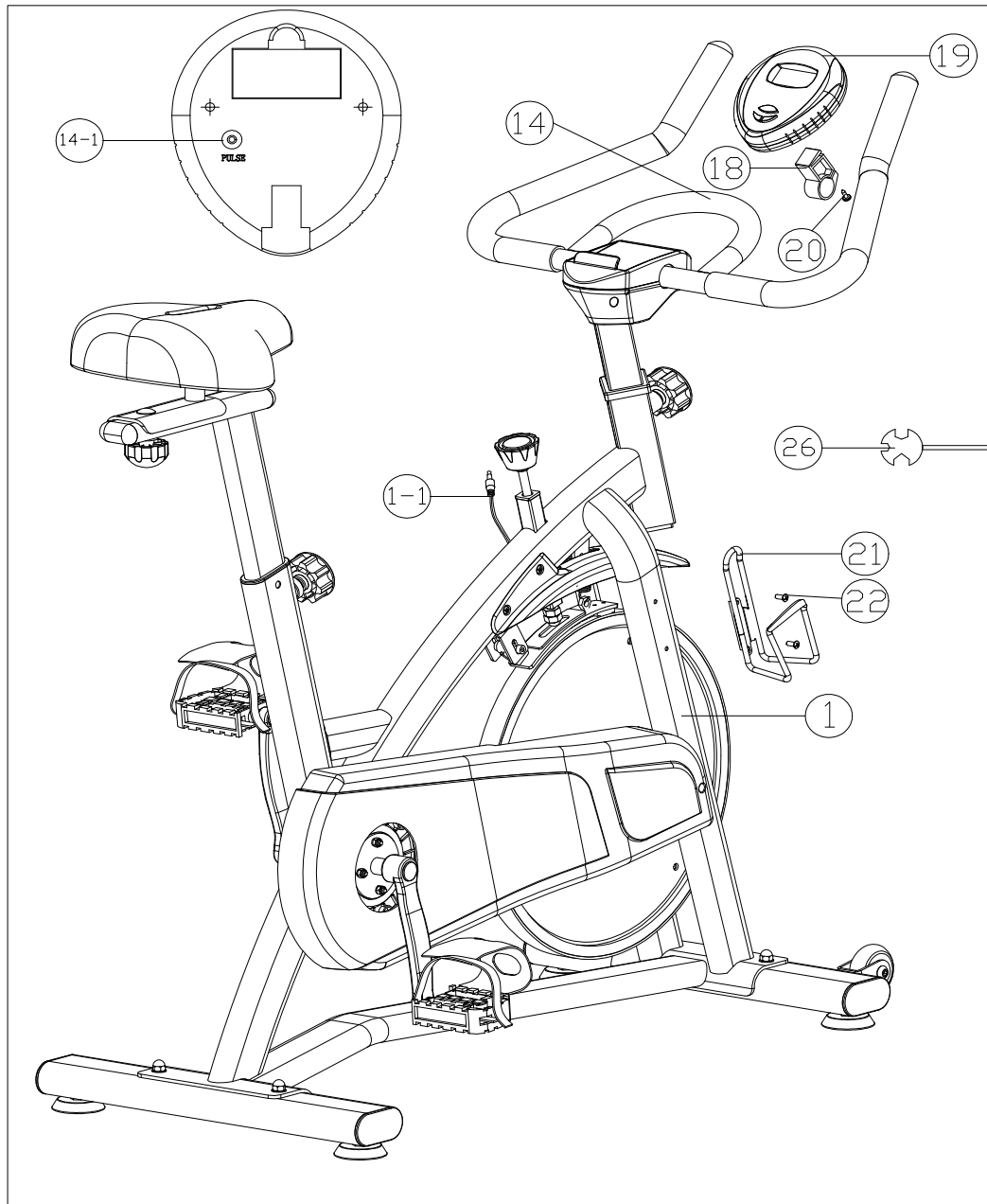

Step 5

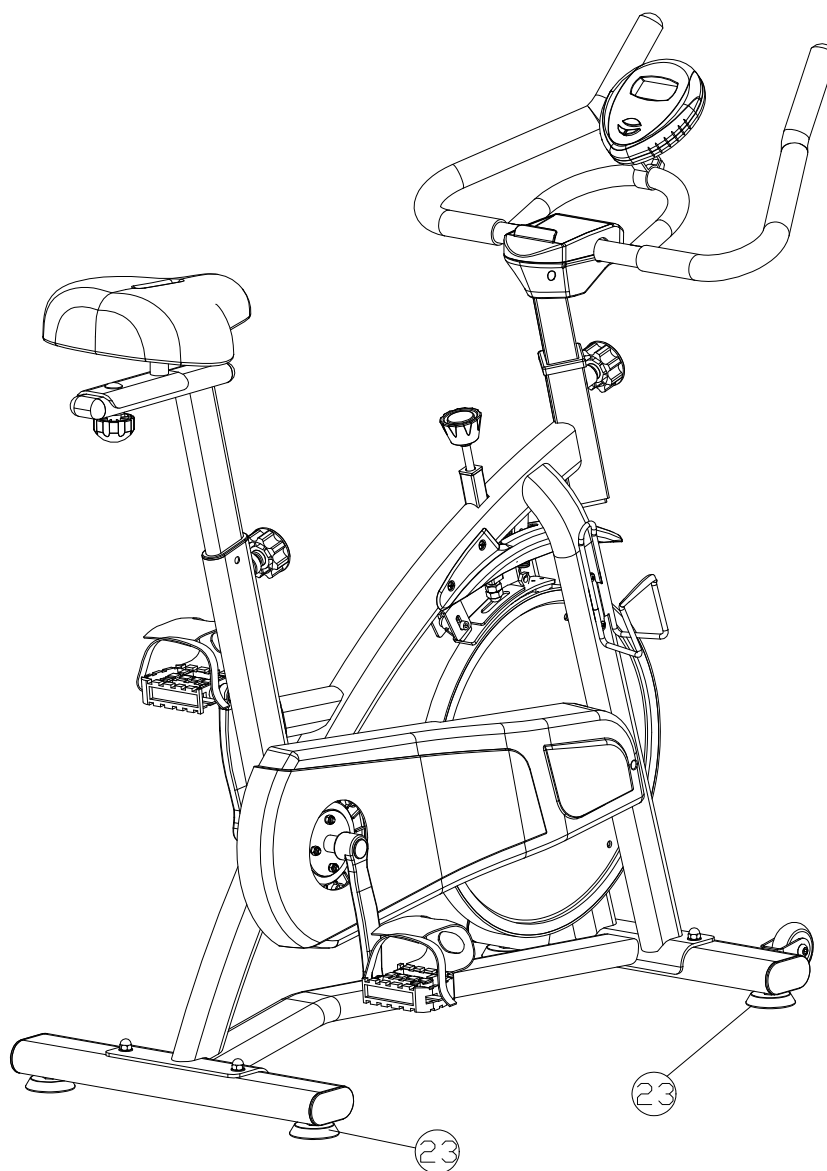

STEP 5

If the spin bike is not stable when riding, please adjust the height of the Adjust mat (23).

COMPUTER OPERATING INSTRUCTIONS

SCAN	Scans all functions – TIME, SPEED, DISTANCE, TOTAL DIST, PULSE, CALORIES
TIME	Displays work out time lapse while exercising
SPEED	Displays the current speed
DISTANCE	Displays the distance while exercising
TOTAL DIST	Displays the total distance at the end of your workout
PULSE	Displays your heart rate
CALORIES	Displays the calories you have burned

1. You will need 2AA batteries (Not provided) to operate the Computer.
2. To select the function you want, press the MODE button and then select the function of choice from the table above.
3. To reset the Computer, hold down the MODE button for 4 seconds.
4. The Computer will automatically turn off after 4 minutes when the bike is not in use. Press any key to restart.
5. To monitor your heart rate, place your thumbs on the heart rate sensor for a few seconds and check the display.
6. To adjust the resistance, turn the tension control to the right (harder), or to the left (easier) .
7. If there is an improper display on the Computer, please replace both batteries with new ones at the same time.
8. To move the bike, hold onto the saddle support pole, lift and push forward.

MAINTENANCE

Regular maintenance will prolong the life of your spin bike and prevent injury. We strongly recommend that you do the following on a regular basis:

1. Clean the bike after use with a soft cloth – ensure it is dry. Note, a build up of moisture over time will cause corrosion.
2. Clean the Computer display with a soft cloth and anti-static computer spray to remove dust or finger prints. **Note**, harsh chemicals will destroy the protective coating on the Computer and cause a static build up inside the Computer that could damage the components.
3. Check the front and back stabilizers each time you use the bike to ensure the bike is stable and level with the floor.
4. Check and tighten loose nuts/buts, the saddle adjustment locks, pedals, and handlebars to ensure they are secure each time you use the bike to avoid injury.
5. A spent battery is hazardous waste, please dispose of it correctly, and do not throw it in the trash.
6. For replacement parts, contact the distributor.