



READ AND SAVE THIS INSTRUCTIONS FOR FUTURE USE

# ASSEMBLY & INSTRUCTION MANUAL

## **Consejos a seguir antes del entrenamiento**

1. Lea el manual cuidadosamente antes de hacer ejercicio.
2. Realice ejercicios de calentamiento antes de utilizar el equipo. Sea consciente de su capacidad y condición física. No use en exceso.
3. Antes de hacer ejercicio, examine cuidadosamente el equipo y asegúrese de que esté en buenas condiciones. Si hay algún defecto, ajústelo y repárelo antes de usarlo. Asegúrese de usar ropa adecuada mientras usa este equipo para evitar posibles circunstancias peligrosas.
4. La máquina está destinada a usuarios mayores de 12 años. Los usuarios menores de 12 años deben hacer ejercicio bajo la supervisión de un adulto.
5. Carga máxima: 150 KG.

**Advertencia:** Si tiene defectos físicos o de movimiento, consulte al médico y al entrenador antes de hacer ejercicio. Por favor, lea el manual cuidadosamente antes de usarlo. No nos hacemos responsables por lesiones personales y daños al equipo causados por un uso inadecuado.

 <p><b>A</b> x 2</p>	 <p><b>I</b> x 1</p>	 <p><b>Q</b> x 2</p>
 <p><b>B</b> x 2</p>	 <p><b>J</b> x 2</p>	 <p><b>R</b> x 2</p>
 <p><b>C</b> x 2</p>	 <p><b>K</b> x 2</p>	 <p><b>S</b> x 8</p>
 <p><b>D</b> x 2</p>	 <p><b>L</b> x 4</p>	 <p><b>T</b> x 2</p>
 <p><b>E</b> x 4</p>	 <p><b>M</b> x 10</p>	 <p><b>U</b> x 2</p>
 <p><b>F</b> x 1</p>	 <p><b>N</b> x 4</p>	 <p><b>V</b> x 12</p>
 <p><b>G</b> x 1</p>	 <p><b>O</b> x 1</p>	 <p><b>W</b> x 2</p>
 <p><b>H</b> x 1</p>	 <p><b>P</b> x 4</p>	 <p><b>X</b> x 2</p>

M8\*12

M8\*45

M8\*12

M8\*80

M8\*45

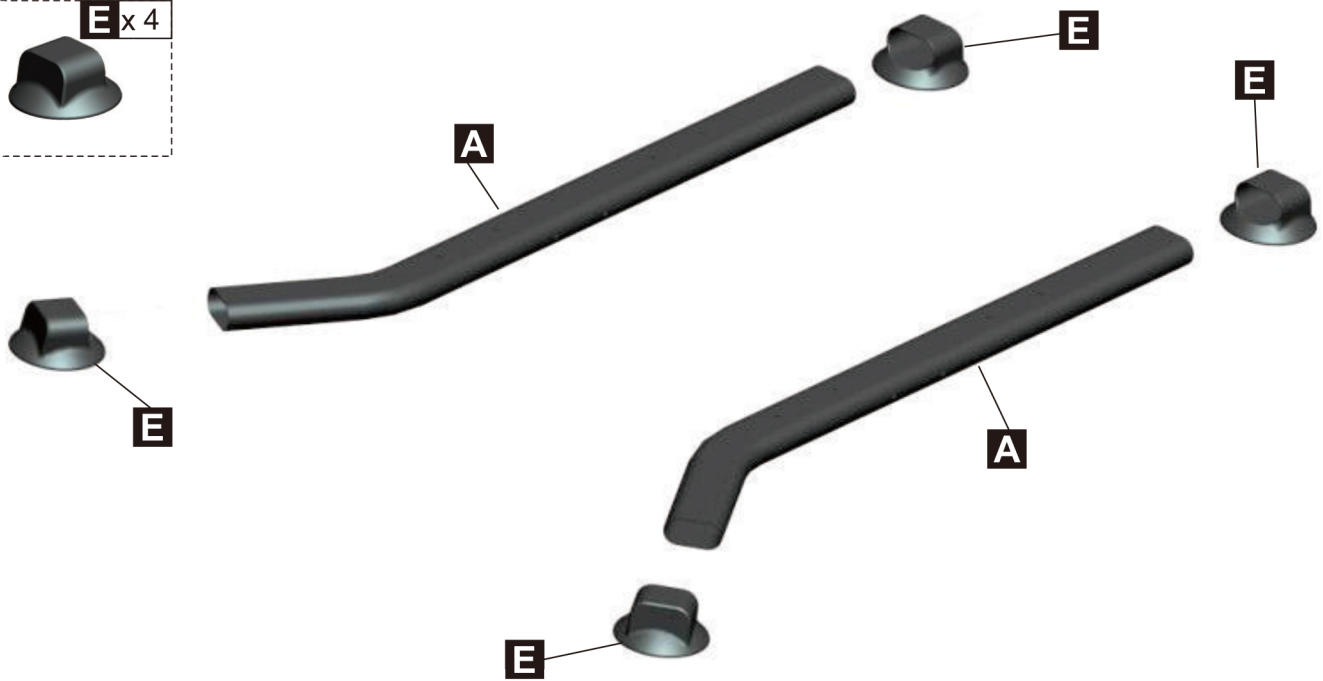

Montaje de encajes: Introduzca 4 encajes en las dos barras de pie. Asegúrese de que el encaje esté paralelo al piso.

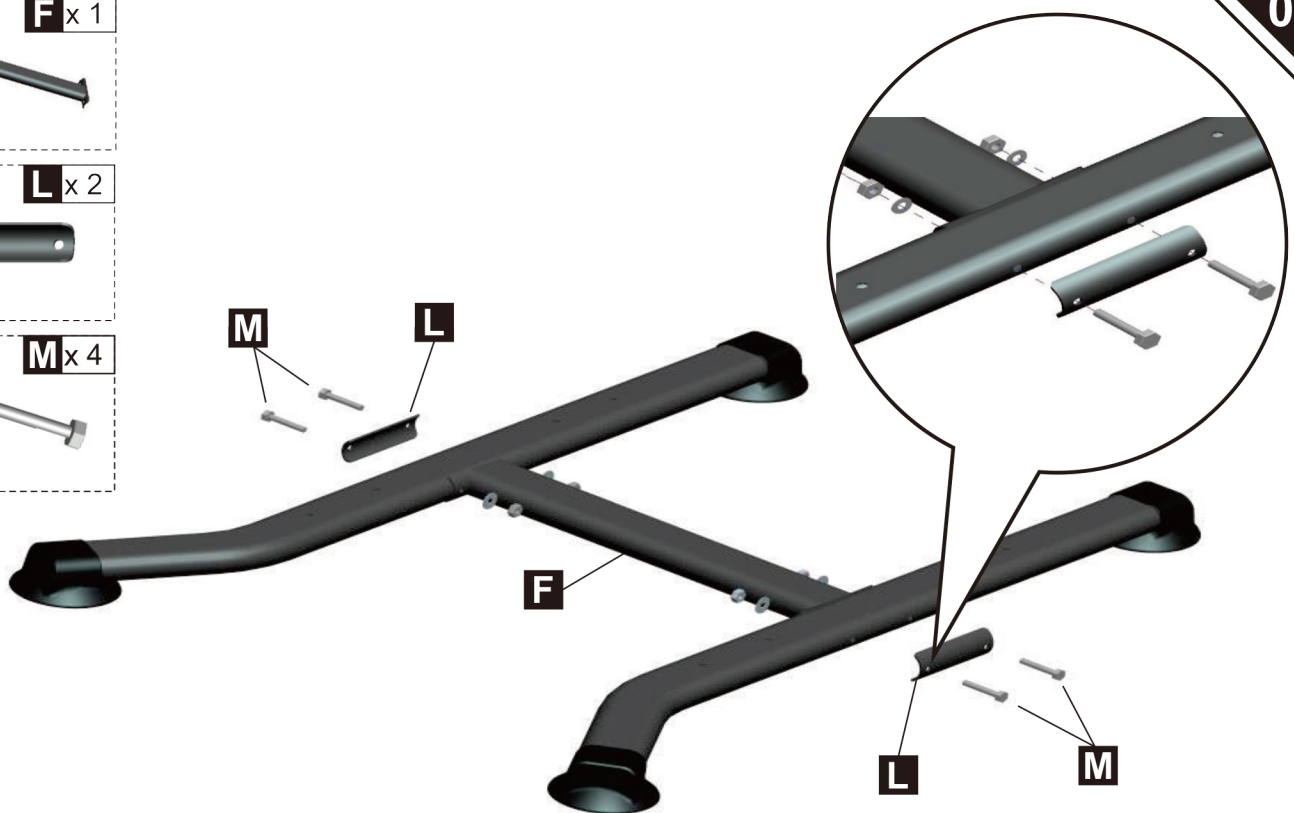
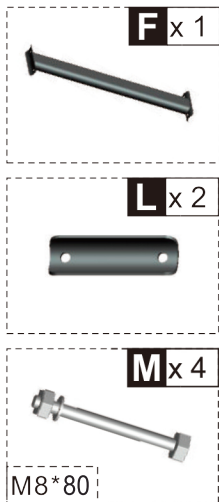

Montaje de la conexión de barra de pie: Fije la barra de pies con 4 tornillos M8 X 45 mm como sigue.

**J** x 2**S** x 4

M8\*45

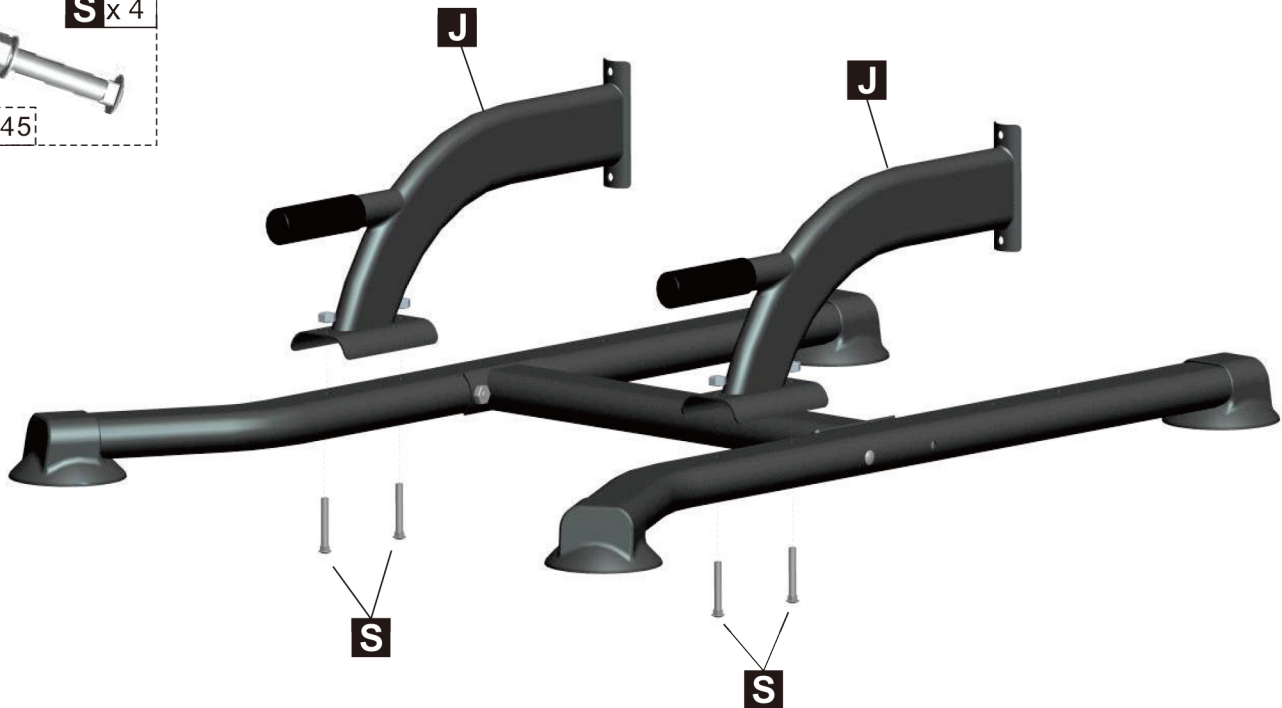

Montaje de barra de soporte: Fije la barra de soporte con las 4 piezas de carruaje de M8 x 45 mm.

**B** x 2**M** x 4

M8\*80

**L** x 2**S** x 4

M8\*45

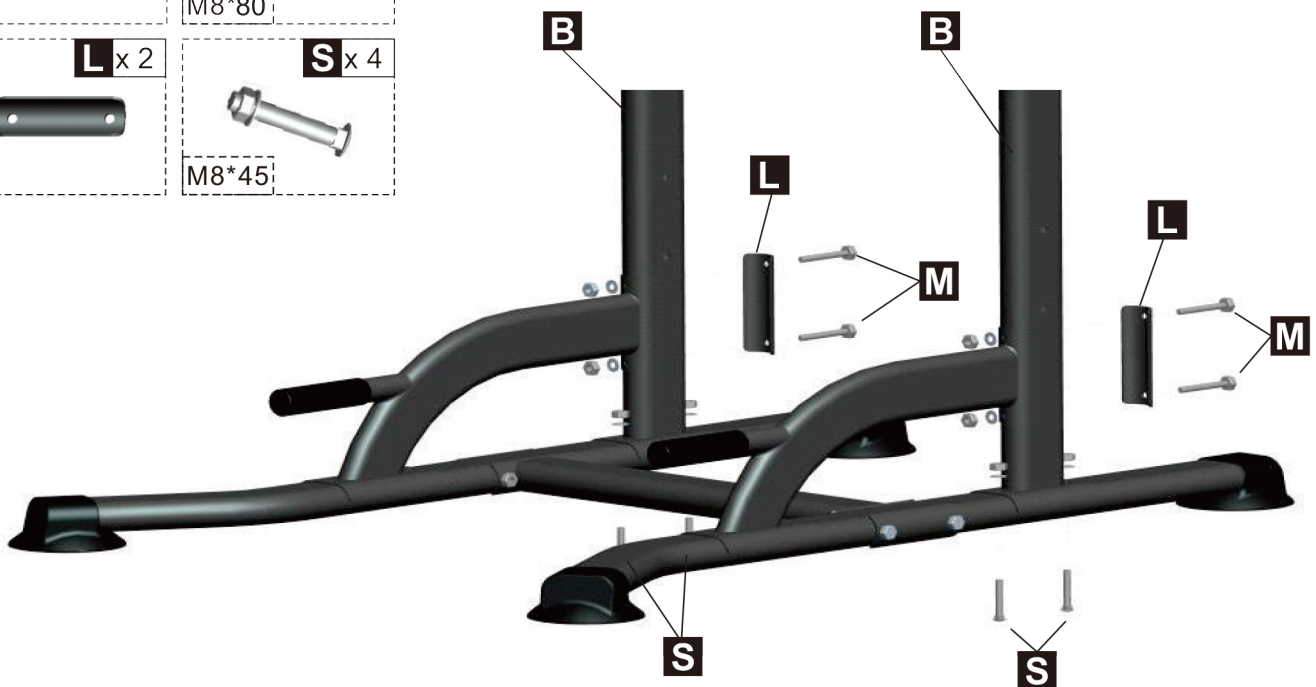

Montaje del marco principal:

1. Fije la parte inferior del marco principal con 4 piezas de carruaje M8 X 45 mm.
2. Fije el marco principal y la barra de soporte con arco de hierro y tornillo hexagonal M8 x75 mm de la siguiente manera.

**H** x 1**N** x 4**P** x 4

M8\*45



Montaje de tubo de conexión de marco principal: Fije el tubo de conexión del marco principal con tornillo hexagonal M8 X 45 mm.

**K** x 2**Q** x 2

M8\*12



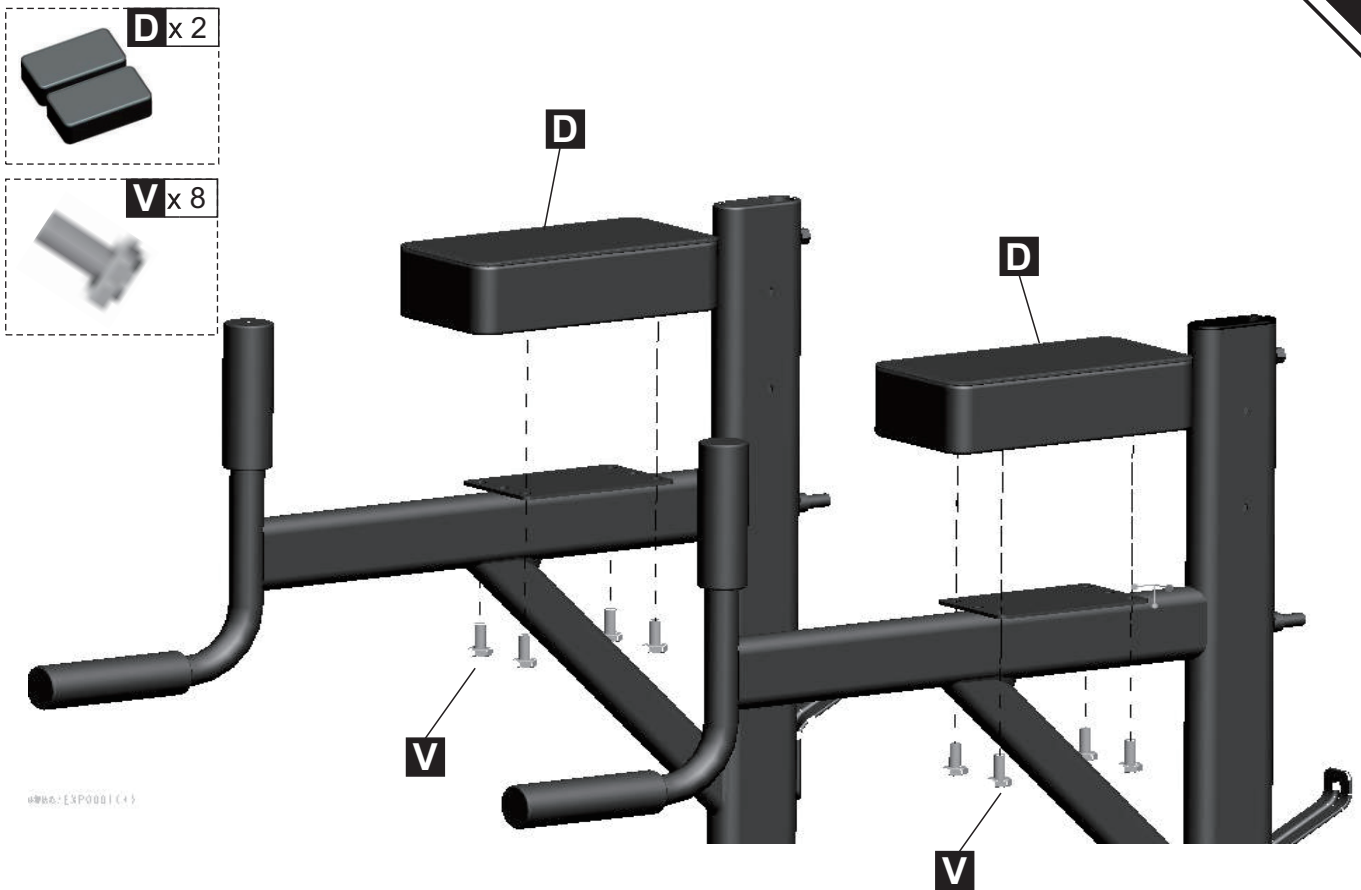

Montaje de reposabrazos: Fije el reposabrazos al marco principal con los tornillos (8 Pz.)

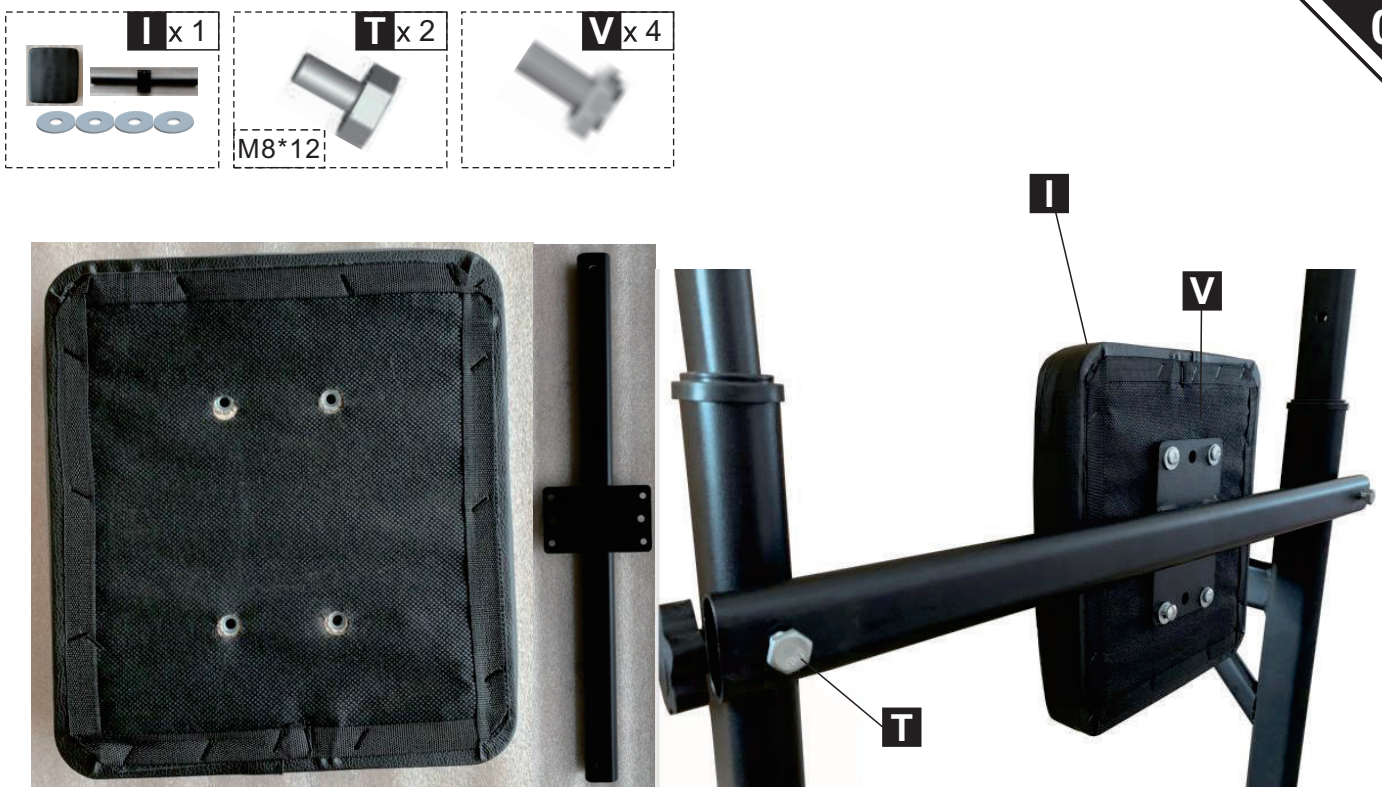

Montaje de Cojín + barra de cojín + regulador:

1. Fije el cojín con 4 tuercas al reposabrazos.
2. Fije el cojín al marco principal con 2 tornillos hexagonales M8 x 12.
3. Instale el tornillo de ajuste.

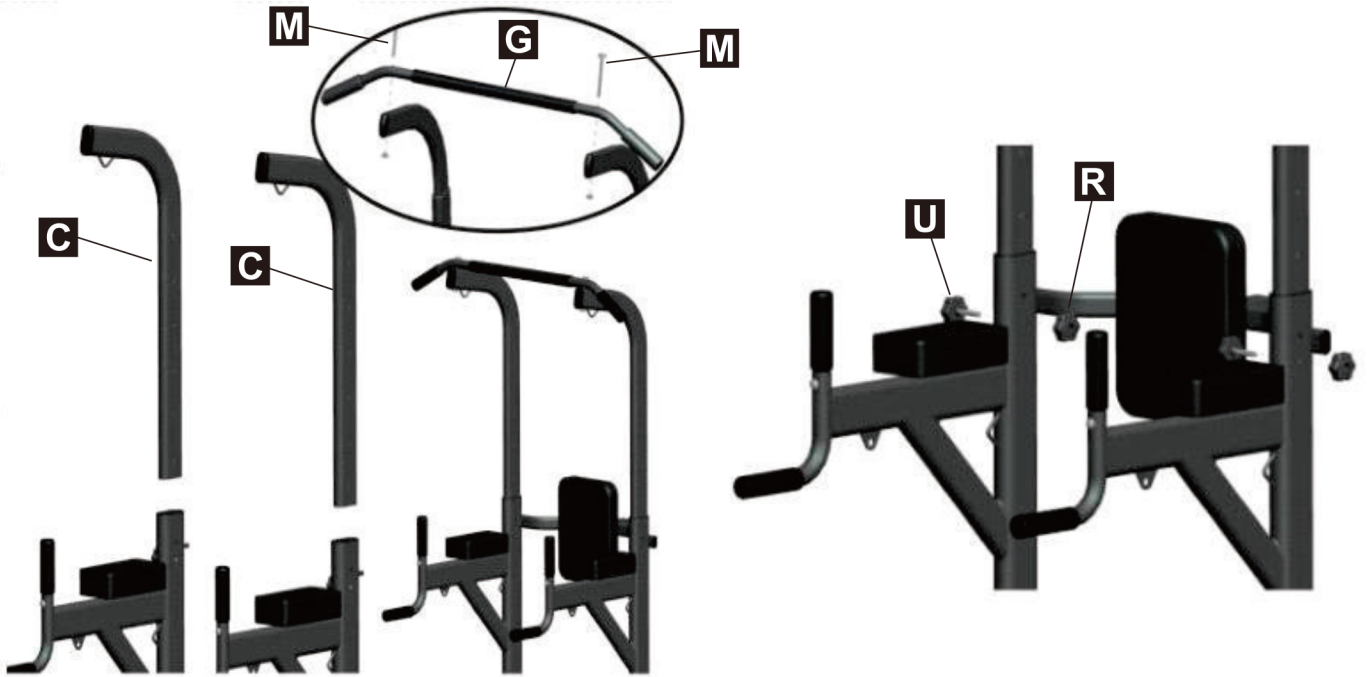
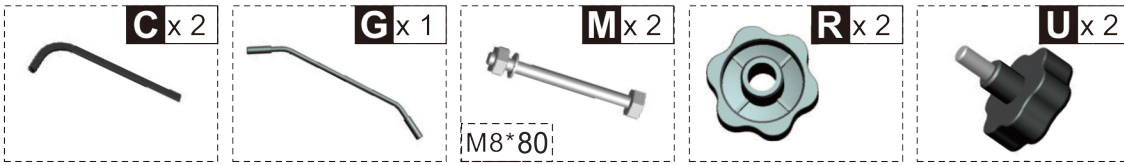

Montaje de barra de soporte y barra de tracción:

1. inserte la barra de soporte en el marco principal con dos tuercas de plástico.
2. Fije la barra de tracción a las dos barras de soporte con un tornillo M8 x 80 mm.

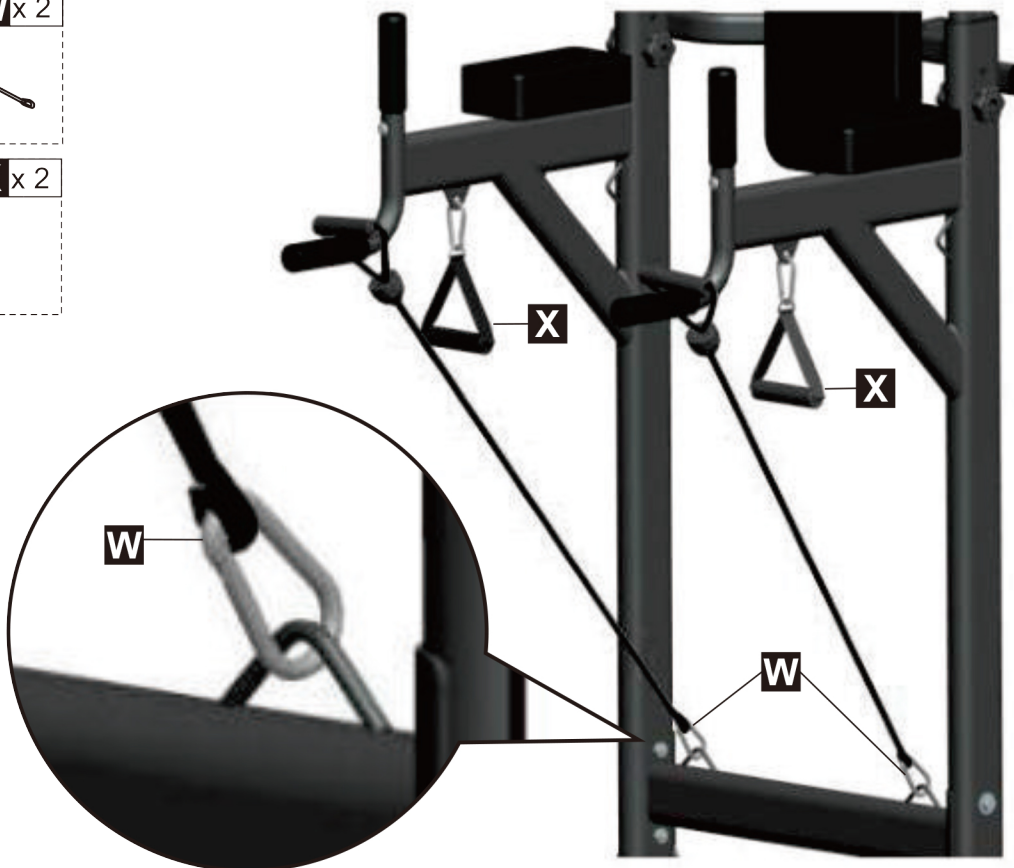
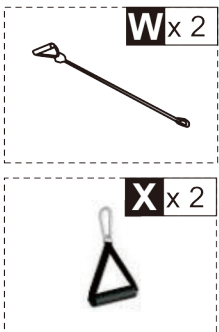

Montado de cuerdas: Coloque la cuerda en la posición correcta como se indica a continuación.





US



001-877-644-9366  
customerservice@aosom.com

CA



001-855-537-6088  
customerservice@aosom.ca

UK



0044-800-240-4004  
enquiries@mhstar.co.uk

DE



0049-(0)40-88307530  
service@aosom.de

FR



0033-1-84166106  
contact@aosom.fr

ES



0034-931294512  
atencioncliente@aosom.es

IT



0039-0249471447  
clienti@aosom.it