



READ AND SAVE THIS INSTRUCTIONS FOR FUTURE USE

ASSEMBLY & INSTRUCTION MANUAL

Notices before exercise

1. Please read the manual carefully before exercise.
2. Please take warm-up exercise before using the equipment. Be aware of your physical ability and condition. Do not overuse.
3. Before exercise, please carefully examine the equipment make sure it is in good condition. If any defect, adjust and repair it before use. Ensure to wear proper outfit while using this equipment to avoid any possible dangerous circumstances.
4. The machine is intend for user over 12 years old. Users under 12 years old should exercise under adult's supervision.
5. Maximum load: 150KGS.

Warning: if there is a physical defects or movement disorders. Please consult the physician and trainer before exercise. Please read the manual carefully before use. We will not responsible for personal injury and damage to the equipment which is caused by improper use.

 <p>A x 2</p>	 <p>I x 1</p>	 <p>Q x 2</p>
 <p>B x 2</p>	 <p>J x 2</p>	 <p>R x 2</p>
 <p>C x 2</p>	 <p>K x 2</p>	 <p>S x 8</p>
 <p>D x 2</p>	 <p>L x 4</p>	 <p>T x 2</p>
 <p>E x 4</p>	 <p>M x 10</p>	 <p>U x 2</p>
 <p>F x 1</p>	 <p>N x 4</p>	 <p>V x 12</p>
 <p>G x 1</p>	 <p>O x 1</p>	 <p>W x 2</p>
 <p>H x 1</p>	 <p>P x 4</p>	 <p>X x 2</p>

M8*12

M8*45

M8*12

M8*80

M8*45

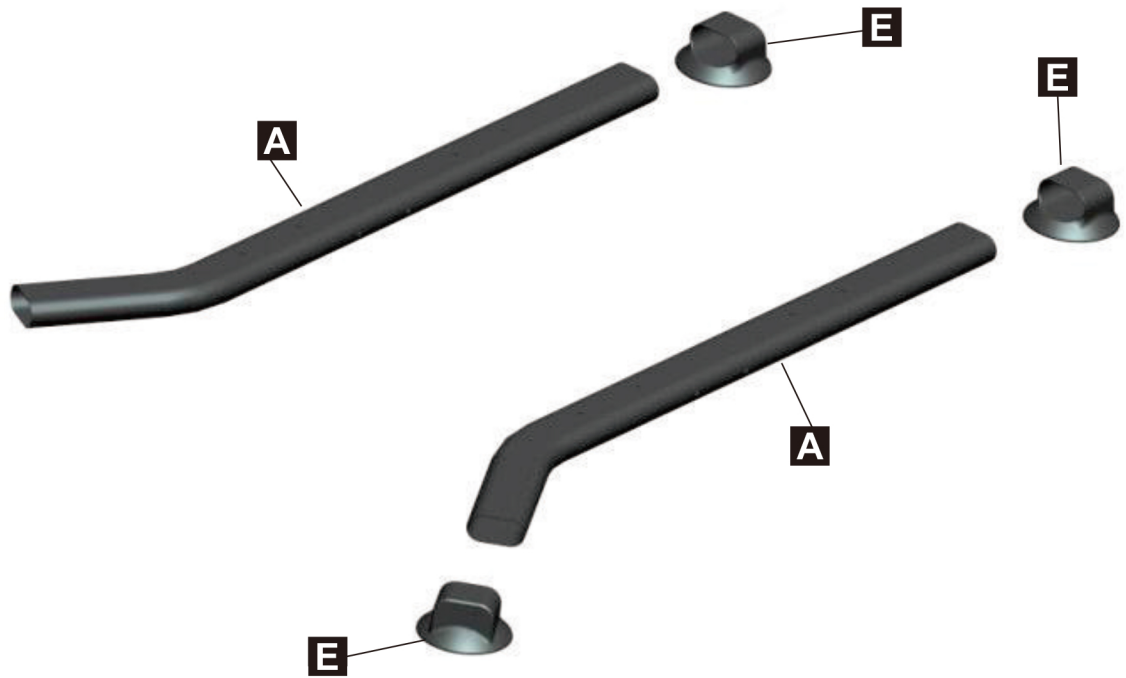

Socket Assembling: Take 4 sockets into the two foot bars (Make sure the socket is parallel to the floor.)

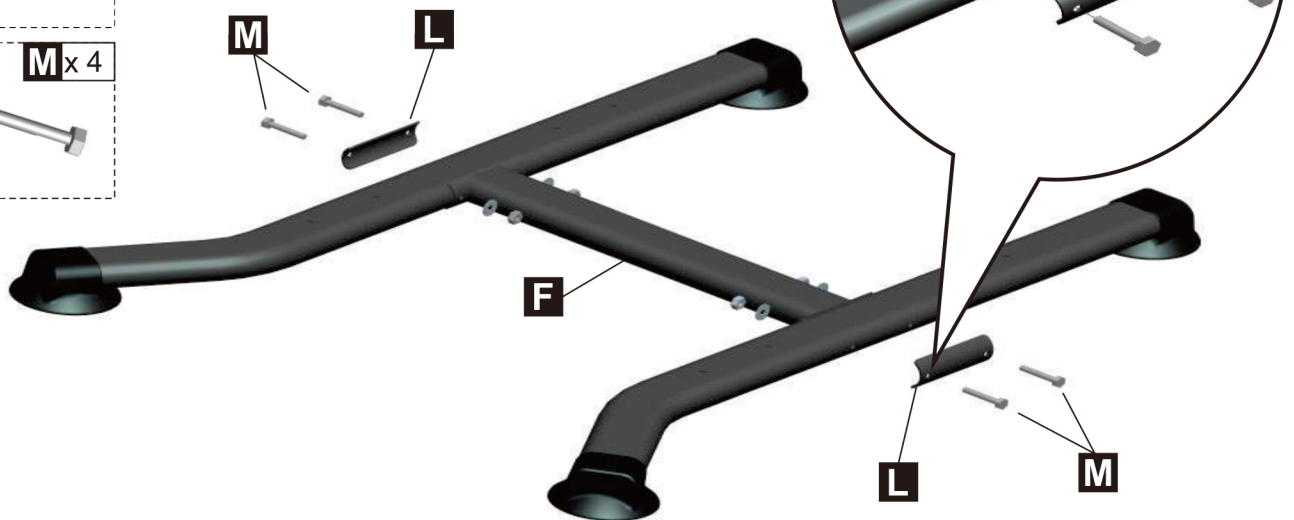
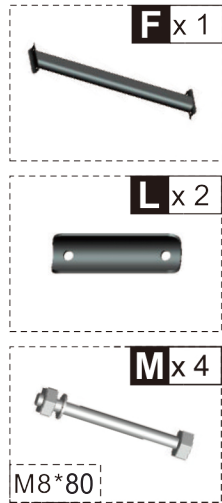

Foot Bar Connecting Pipe Assembling: Fix the foot bar with 4 M8X75mm screw. As follow,

J x 2**S** x 4

M8*45

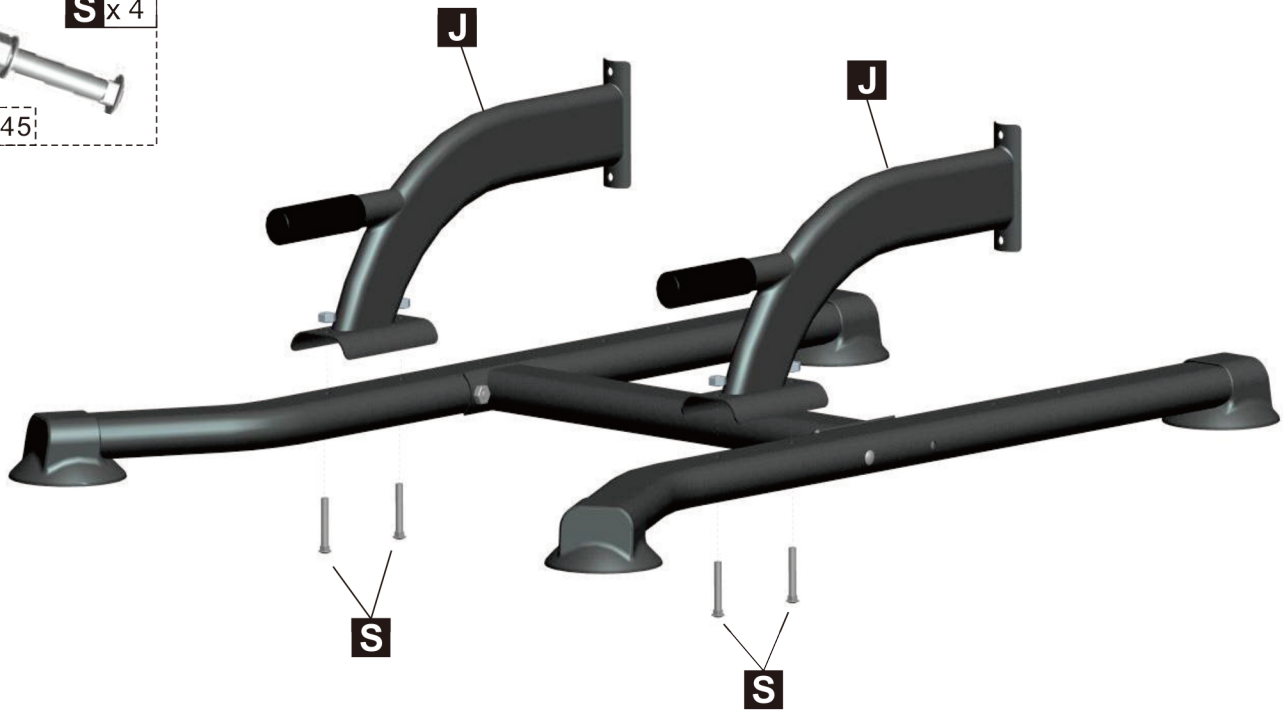

Supporting bar Assembling: Fix the supporting bar with 4 pcs carriage M8*45mm.

B x 2**M** x 4

M8*80

L x 2**S** x 4

M8*45

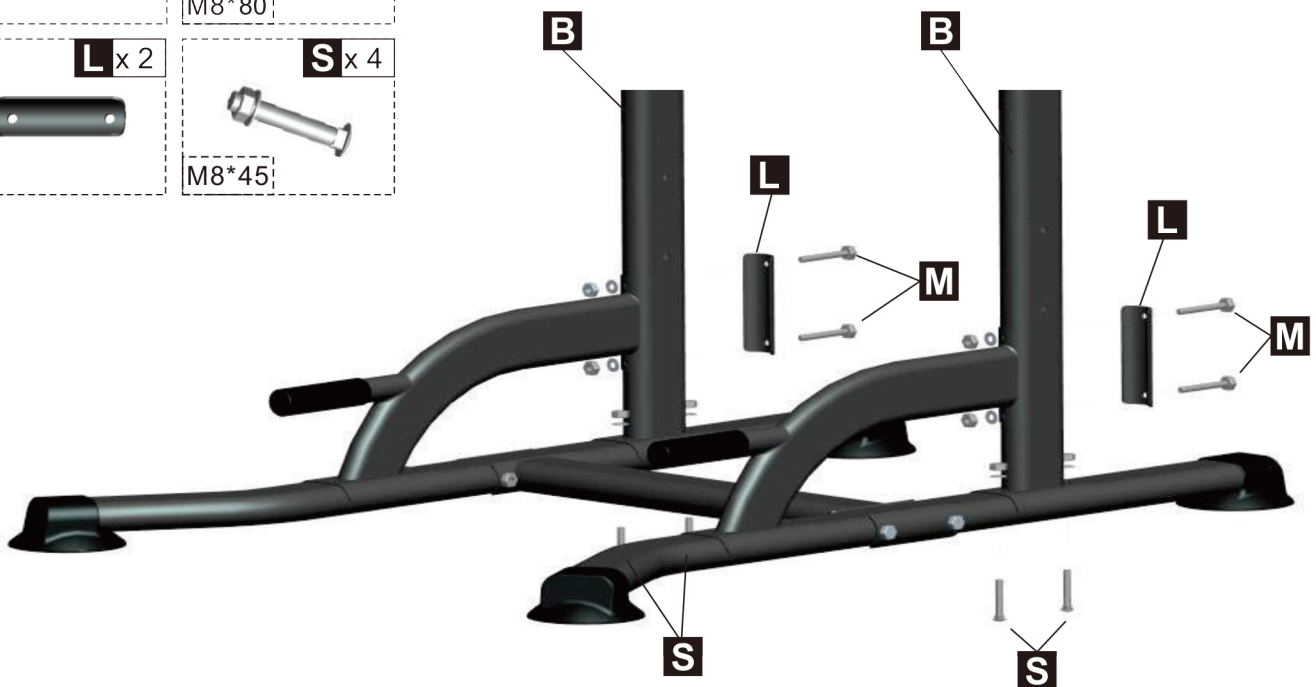

Main frame Assembly:

1. Fix the main frame bottom with 4pcs Carriage M8X45mm
2. Fix the main frame and supporting bar with Arc iron and hex(agonal)screw M8x75mm. As follow

H x 1**N** x 4**P** x 4

M8*45



Main frame connecting pipe Assembly: Fix the main frame connecting pipe with hex (agonal) screw M8X45mm

K x 2**Q** x 2

M8*12



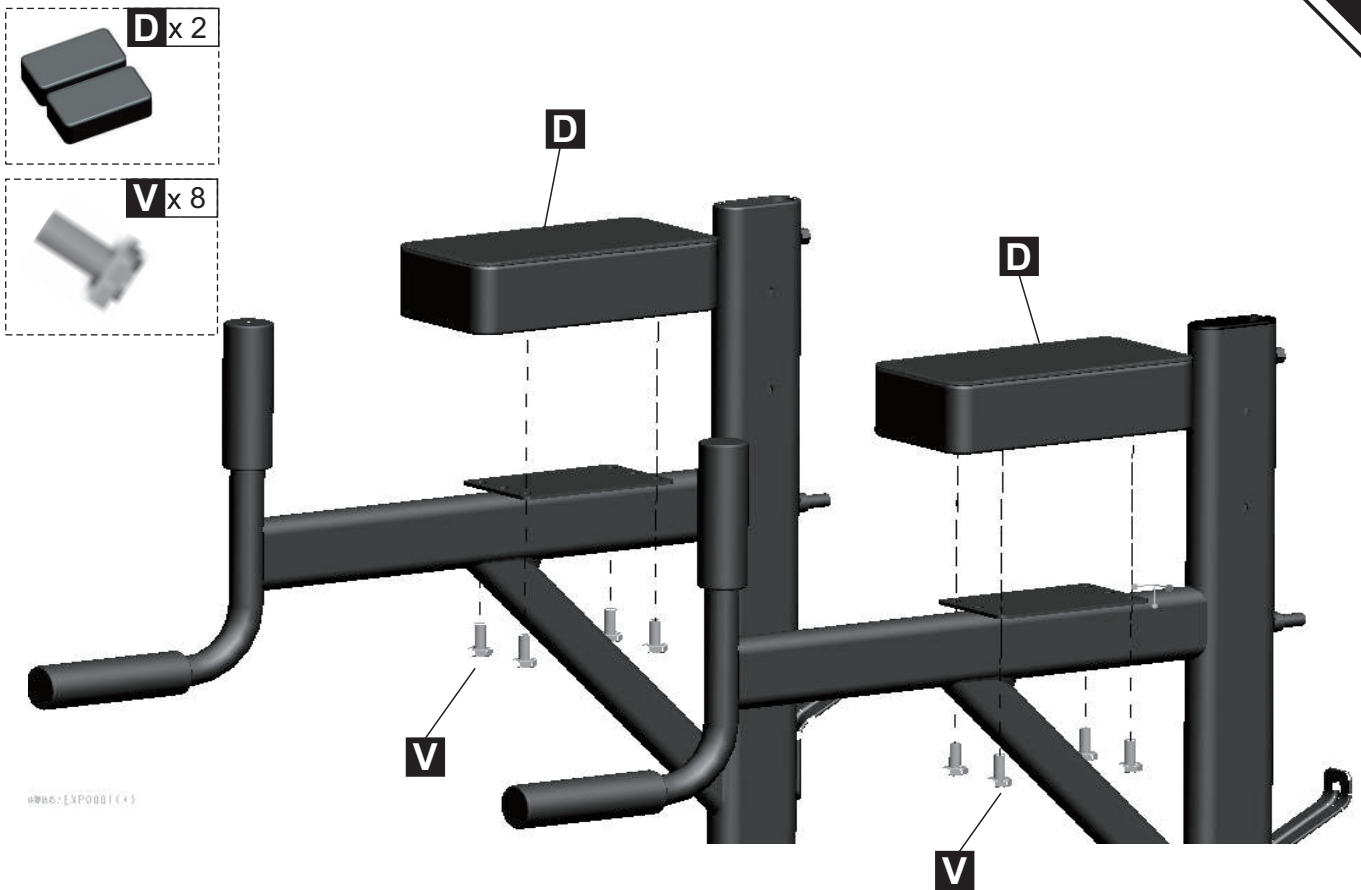

Armrest Assembly: Fix the armrest to the main frame with 8 pcs.

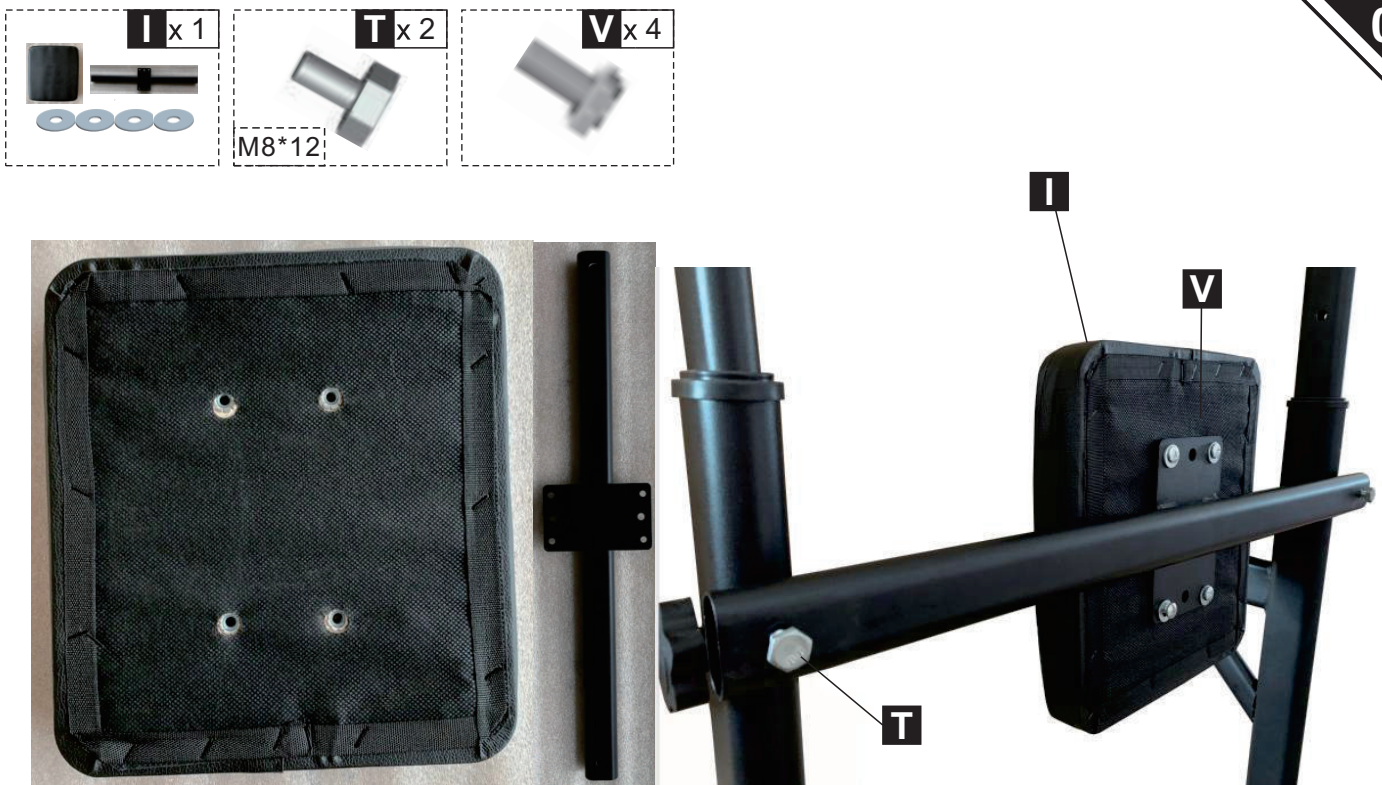

Cushion+cushion bar Assembly:

1. fix the cushion with 4pcs armrest nuts.
2. Fix the cushion to the main frame with 2pcs Hex(agonal)screw M8*12.
3. Install the adjusting screw.

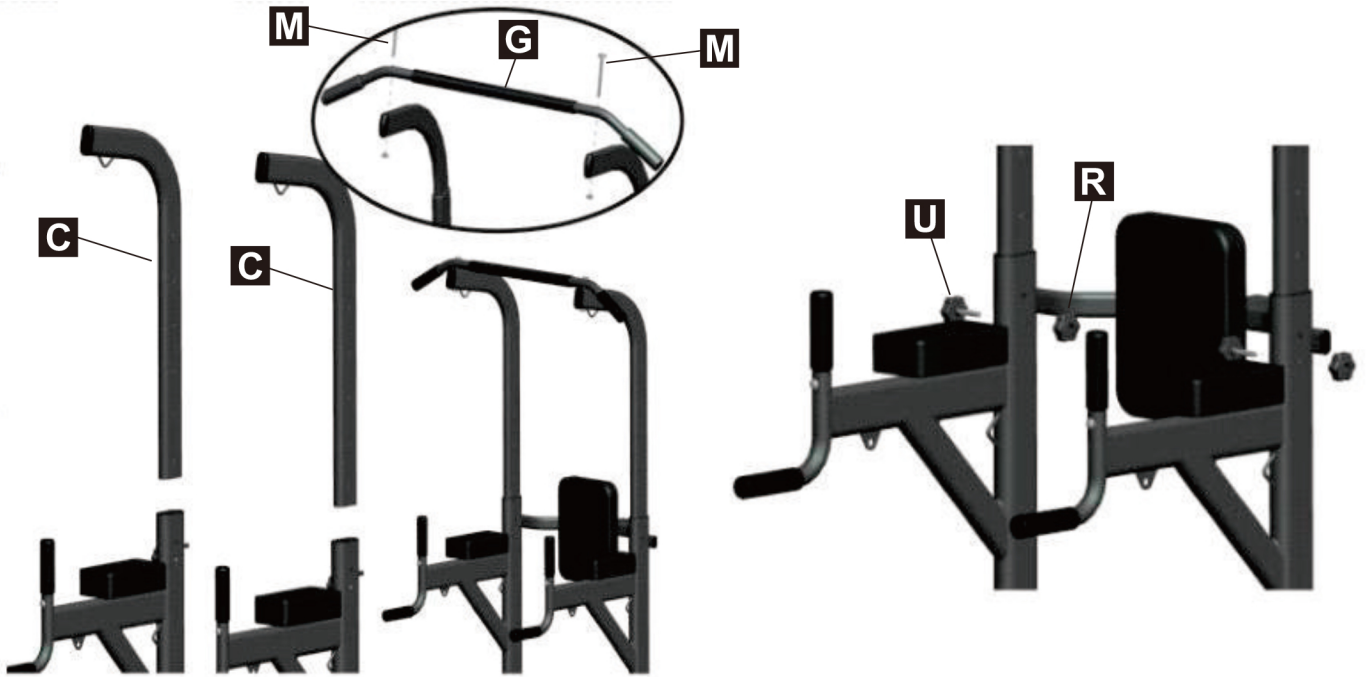
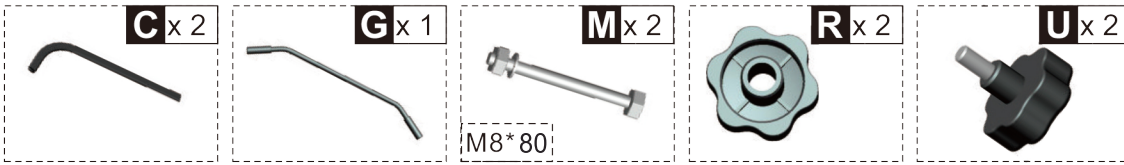

Supporting bar&Pull bar Assembly:

1. insert the supporting bar to the main frame with two plastic nuts.
2. Fix the pull bar to the two supporting bar with M8x75mm screw.

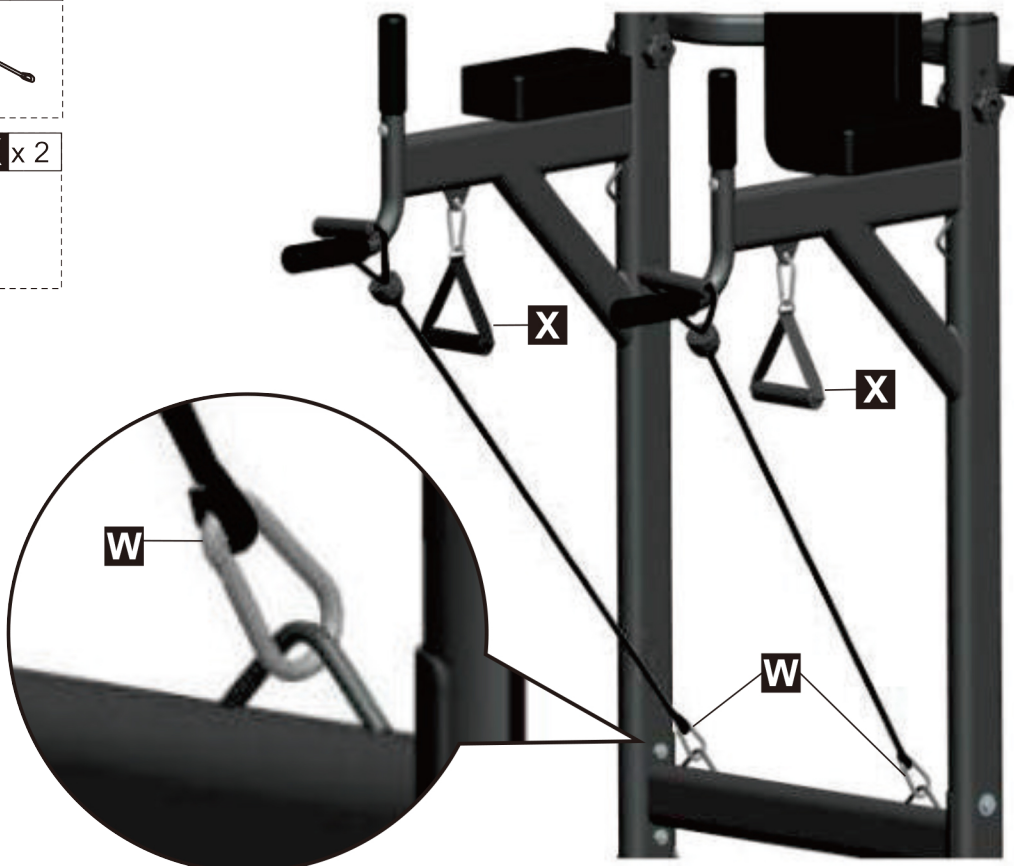
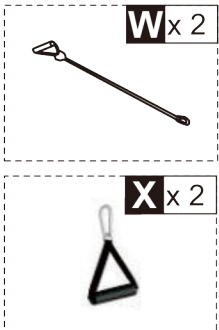

Rope Assembling: Take the rope in right position, as follow



US



001-877-644-9366
customerservice@aosom.com

CA



001-855-537-6088
customerservice@aosom.ca

UK



0044-800-240-4004
enquiries@mhstar.co.uk

DE



0049-(0)40-88307530
service@aosom.de

FR



0033-1-84166106
contact@aosom.fr

ES



0034-931294512
atencioncliente@aosom.es

IT



0039-0249471447
clienti@aosom.it