



INade057V04\_UK

**A91-092**



## **POWER TOWER MANUAL**











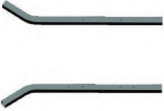
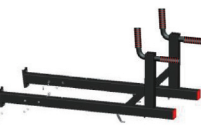



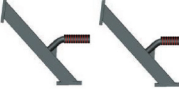







READ AND SAVE THIS INSTRUCTION FOR FUTURE USE

# **ASSEMBLY INSTRUCTION**

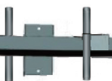
# Installation

## Step 1: Open package to confirm product components

### Accessories

- A Foot tube (2pcs)**  

- B Main Frame (including tube cover)**  

- C Upper Tube (2pcs)**  

- D Elbow pad one pair**  

- E Bottom tube cover (4pcs)**  

- F Supporting Tube**  

- G Gym Bar (including hand gloves)**  

- H Base Connection tube**  

- I Hand Gloves (4pcs)**  

- J Main Frame Connection Tube**  

- K Screw M8x65mm (22pcs)**  

- M Wrench 13-17 (2pcs)**  

- N Screw M8x75 (2pcs)**  

- O screw 8x60 (2pcs)**  

- P Screw Nut M8 (2pcs)**  

- Q Screw M8x55 (4pcs)**  

- R Back Set Tube**  

- T Leg Tube**  

- U Sit Up Bench (Back Set)**  

- V Plastic gasket**  

- W Bolt 8x66 (2pcs)**  

- X Screw M10x20mm (2pcs)**  

- Y Screw (1pcs)**  

- Z Screw M8x55 (1pcs)**  

## Step 11: Folding storage:

### Accessories:

- W Bolt 8x66 (1pcs)**
- Y Screw (1pcs)**



Take out the Bolt and fold it



Use Screw fix the sit up bench

**Step 10: Assembly Foot tube**

**K Screw** M8x65mm+big gasket dia30(2pcs)

**T** foot tube

**W Bolt** 8x66(1pcs)

**Q Screw** M8x55 (1pcs)

**I Hand Gloves** (4pcs)

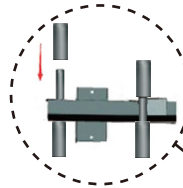

Insert the hand gloves  
(Note: Use a little water will be more easy)

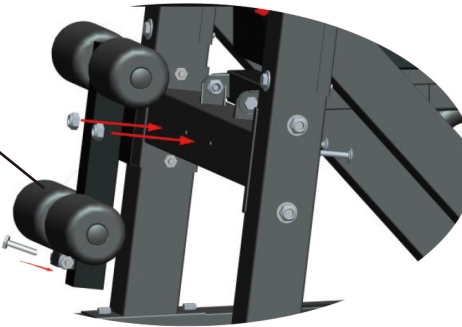

Use Screw M8x65mm (add 2 big gasket)



Bolt adjust the sit up bench foldable or not

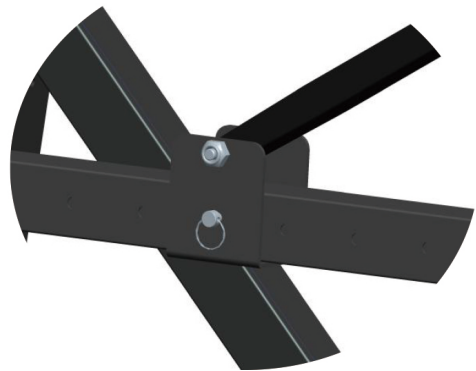

**Step 2: Assembly 4 foot covers**

**Accessories:**

**E Foot Cover** (4pcs)

**A Foot Tube** 2 pcs

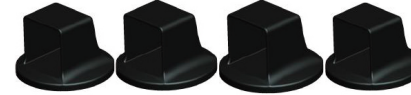

Use 4 foot covers to insert into the foot tube

**Step 3: Assembly the bottom connection tube**

**Accessories:**

**H Bottom Connection Tube**

**K Screw** M8x65mm(4pcs)



Screw M8x65

**Step 4: Assembly Main Frame**

Accessories:

**B** Main Frame



**K** Screw M8x65mm(12pcs)



**F** Supporting Tube



**Step 9: Assembly sit up bench ( Using )**

**V** Plastic Gasket

**X** Screw M10x20mm(2pcs)

**U** Sit Up bench ( Back set )

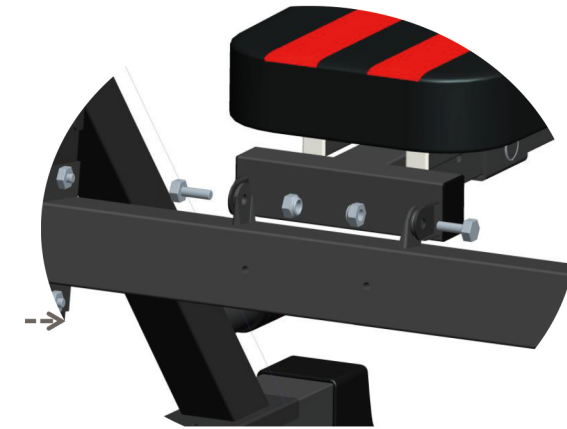

Use screw M10X20 add gasket in the middle

**Step 8:** Adjust suitable angles and heights

Accessories:

○ Screw 8x60 (2pcs)



P Screw Nut M8 (2pcs)

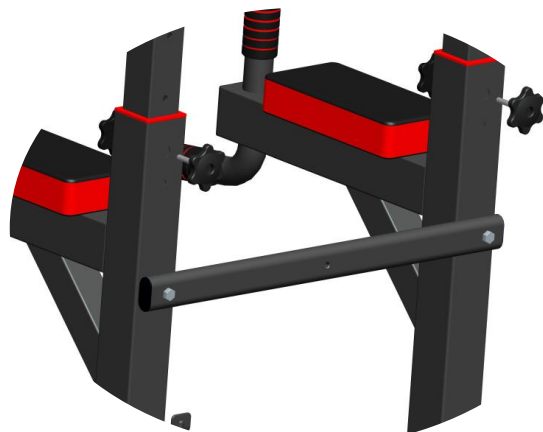

Use Screw 8x60 Fix  
Totally 7 adjustment

Installation complete without bench (See pic)

**Step 5:** Assembly Main Frame Connection Tube with bench connection tube

K Screw M8x65mm(4pcs)



J Main Frame Connection



Screw M8x65mm  
(Outside use bigger gasket)

Accessories:

R Sit up bench Tube

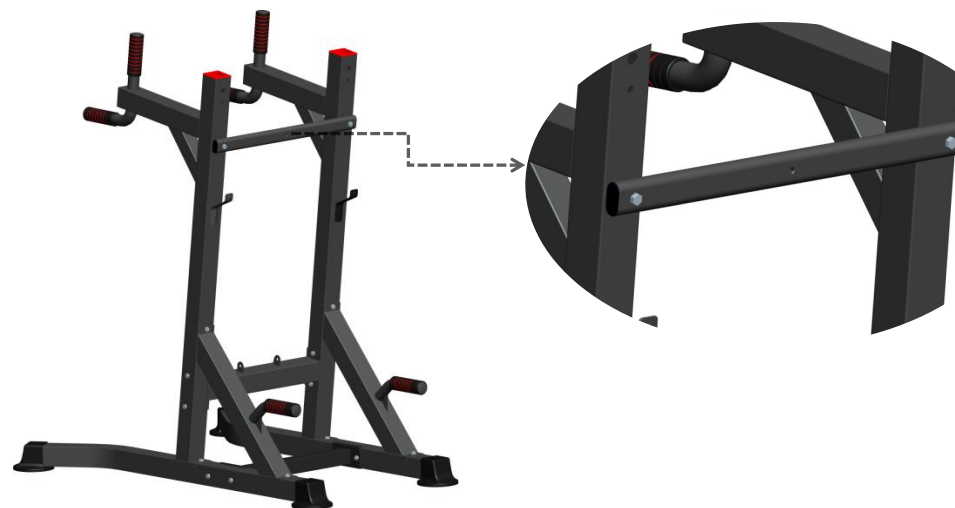

**Step 6:** Assembly Elbow pad

Accessories: **Q** Screw M8x55 (4pcs)

**D** Elbow pad one pair

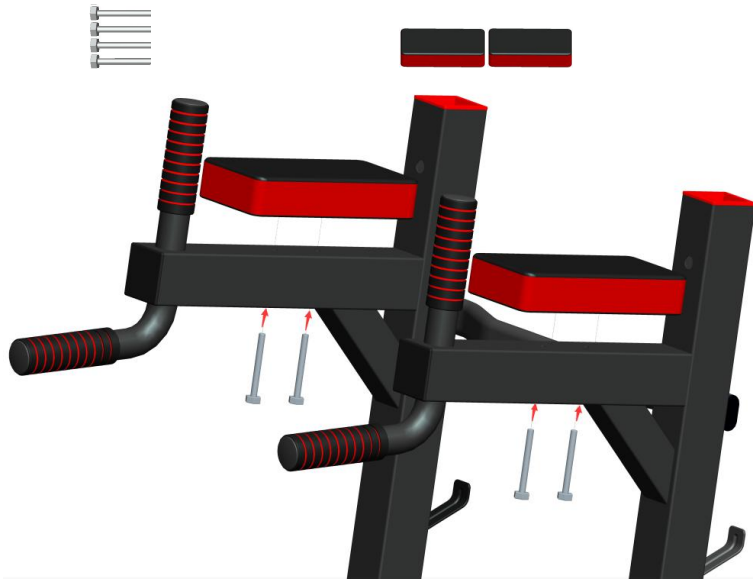

**Step 7:** Assembly upper tube and gym bar

Accessories:

**C** Upper Tube (2pcs)

**G** Gym Bar(with hand gloves)

**N** Screw M8x75 (2pcs)

