

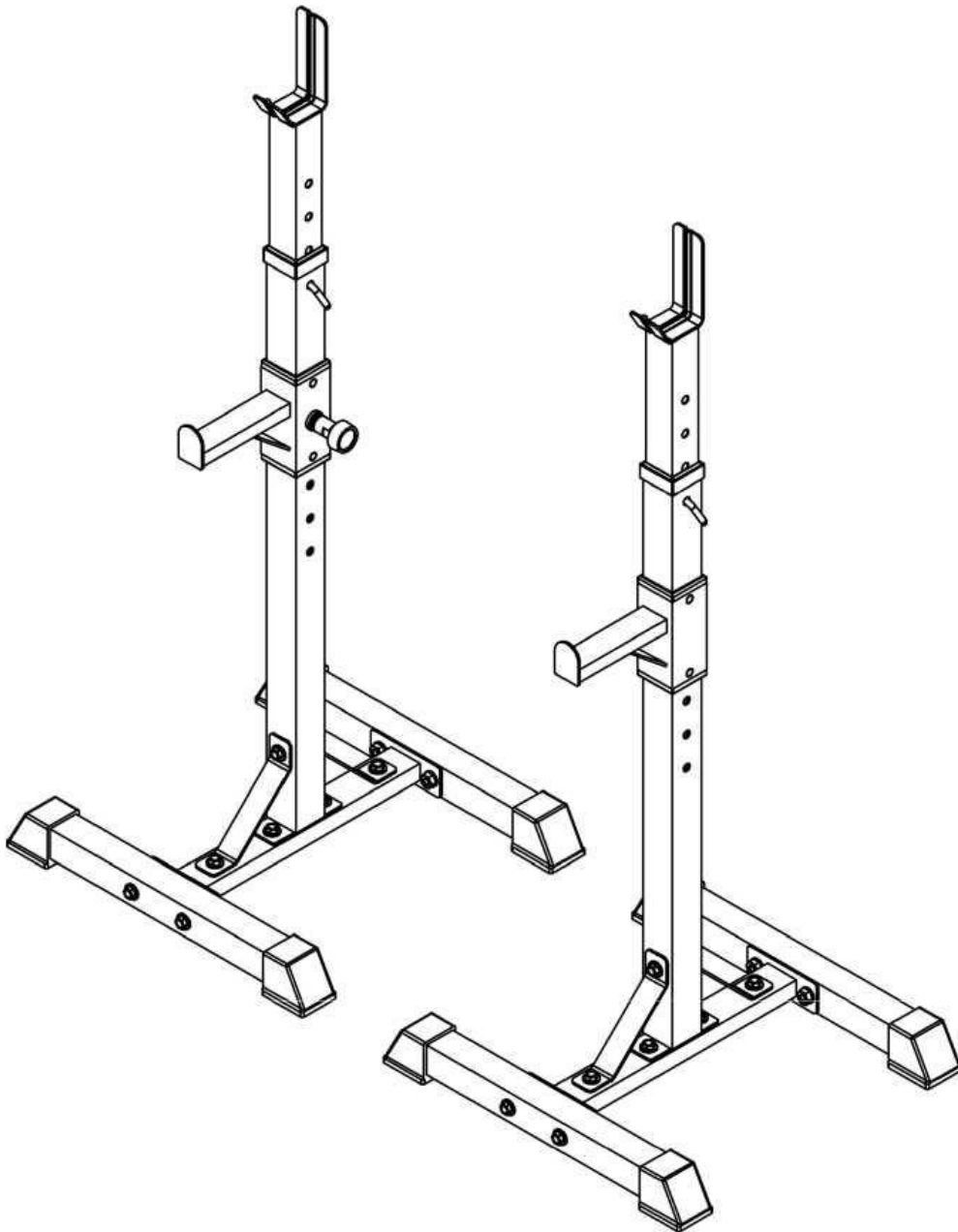

INadf016V01\_UK

**A91-174V01**



IMPORTANT, RETAIN FOR FUTURE REFERENCE: READ CAREFULLY

**ASSEMBLY INSTRUCTION**

# Important Safety Information

**Please keep this manual in a safe place for reference.**

1. It is important to read this entire manual before assembling and using the equipment. Safe and efficient use can only be achieved if the equipment is assembled, maintained and used properly. It is your responsibility to ensure that all users of the equipment are informed of all warnings and precautions.
2. Before starting any exercise program you should consult your doctor to determine if you have any physical or health conditions that could create a risk to your health and safety, or prevent you from using the equipment properly. Your doctor's advice is essential if you are taking medication that affects your heart rate, blood pressure or cholesterol level.
3. Be aware of your body's signals. Incorrect or excessive exercise can damage your health. Stop exercising if you experience any of the following symptoms: Pain, tightness in your chest, irregular heartbeat, extreme shortness of breath, feeling light headed, dizzy or nauseous. If you do experience any of these conditions you should consult your doctor before continuing with your exercise program.
4. Keep children and pets away from the equipment. The equipment is designed for adult use only.
5. Use the equipment on a solid, flat level surface with a protective cover for your floor or carpet. For safety, the equipment should have at least 0.5 meter of free space all around it.
6. Before using the equipment, check the nuts and bolts are securely tightened.
7. The safety level of the equipment can only be maintained if it is regularly examined for damage and/or wear and tear.
8. Always use the equipment as indicated. If you find any defective components whilst assembling or checking the equipment, or if you hear any unusual noise coming from the equipment during use, stop. Do not use the equipment until the problem has been rectified.
9. Wear suitable clothing whilst using the equipment. Avoid wearing loose clothing which may get caught in the equipment or that may restrict or prevent movement.
11. The equipment is not suitable for therapeutic use.
12. Care must be taken when lifting or moving the equipment so as not to injure your back. Always use proper lifting techniques and/or use assistance.

# EXPLODED DRAWING

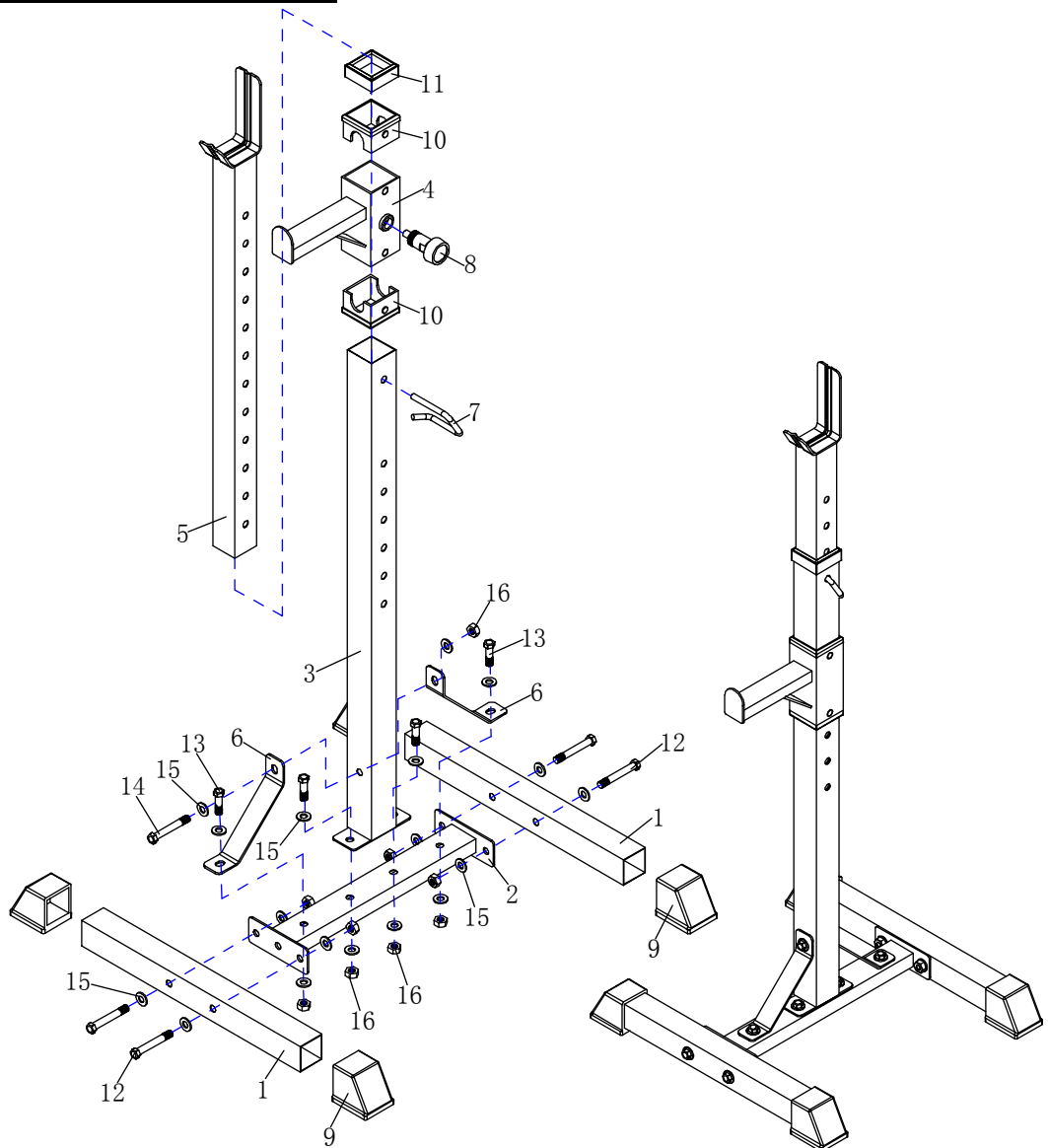

## PART LIST

| PART NO. | DESCRIPTION          | QTY |
|----------|----------------------|-----|
| 1.       | Base Tube            | 4   |
| 2.       | Connect Tube         | 2   |
| 3.       | Stand Tube           | 2   |
| 4.       | Adjustable Tube      | 2   |
| 5.       | Support Tube         | 2   |
| 6.       | Support Plate        | 4   |
| 7.       | Safety Pin           | 2   |
| 8.       | Quick Pin            | 2   |
| 9.       | Foot Cap             | 8   |
| 10.      | 60x50 Mid-empty Plug | 4   |
| 11.      | 50x45 Mid-empty Plug | 2   |
| 12.      | M10x65 Hex Bolt      | 8   |
| 13.      | M10x40 Hex Bolt      | 8   |
| 14.      | M10x70 Hex Bolt      | 2   |
| 15.      | M10 Washer           | 36  |
| 16.      | M10 Nylon Nut        | 18  |

# ASSEMBLY DRAWING

## Step 1

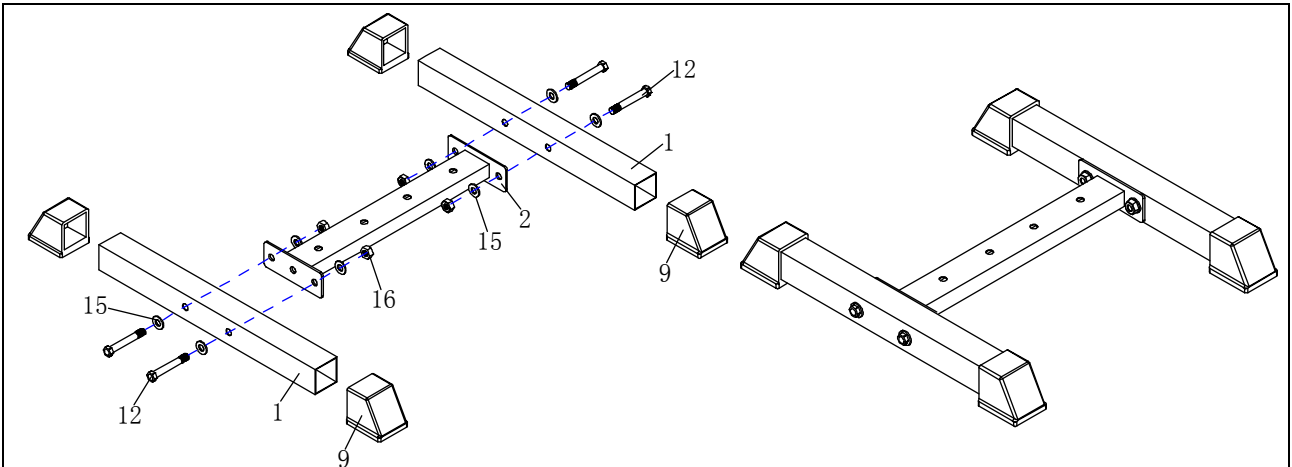

### Assembly of the base frame

- 1) Assemble the foot cap (9) to the base tube (1).
- 2) Screw together the base tube (1) to the connect tube (2), secured with hex bolt (12-4pcs), washer (15-8pcs) and nylon nut (16-4pcs).

## Step 2

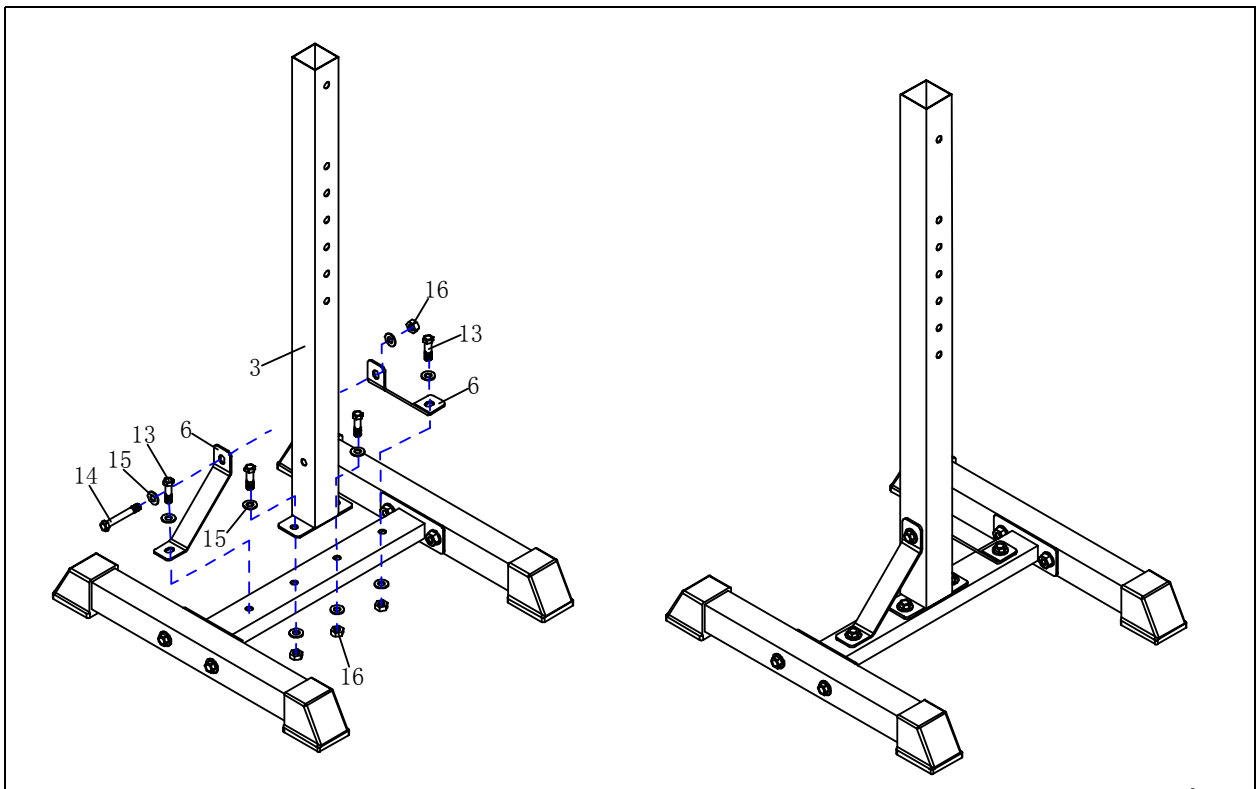

### Assembly of the stand tube

- 1) Screw together the stand tube (3) to the connect tube (2), secured with hex bolt (13-2pcs), washer (15-4pcs) and nylon nut (16-2pcs).
- 2) Screw together the support plate (6) to the connect tube (2), secured with hex bolt (13-2pcs), washer (15-4pcs) and nylon nut (16-2pcs).
- 3) Screw together the support plate (6) to the stand tube (3), secured with hex bolt (14-1pc), washer (15-2pcs) and nylon nut (16-1pc).

### Step 3

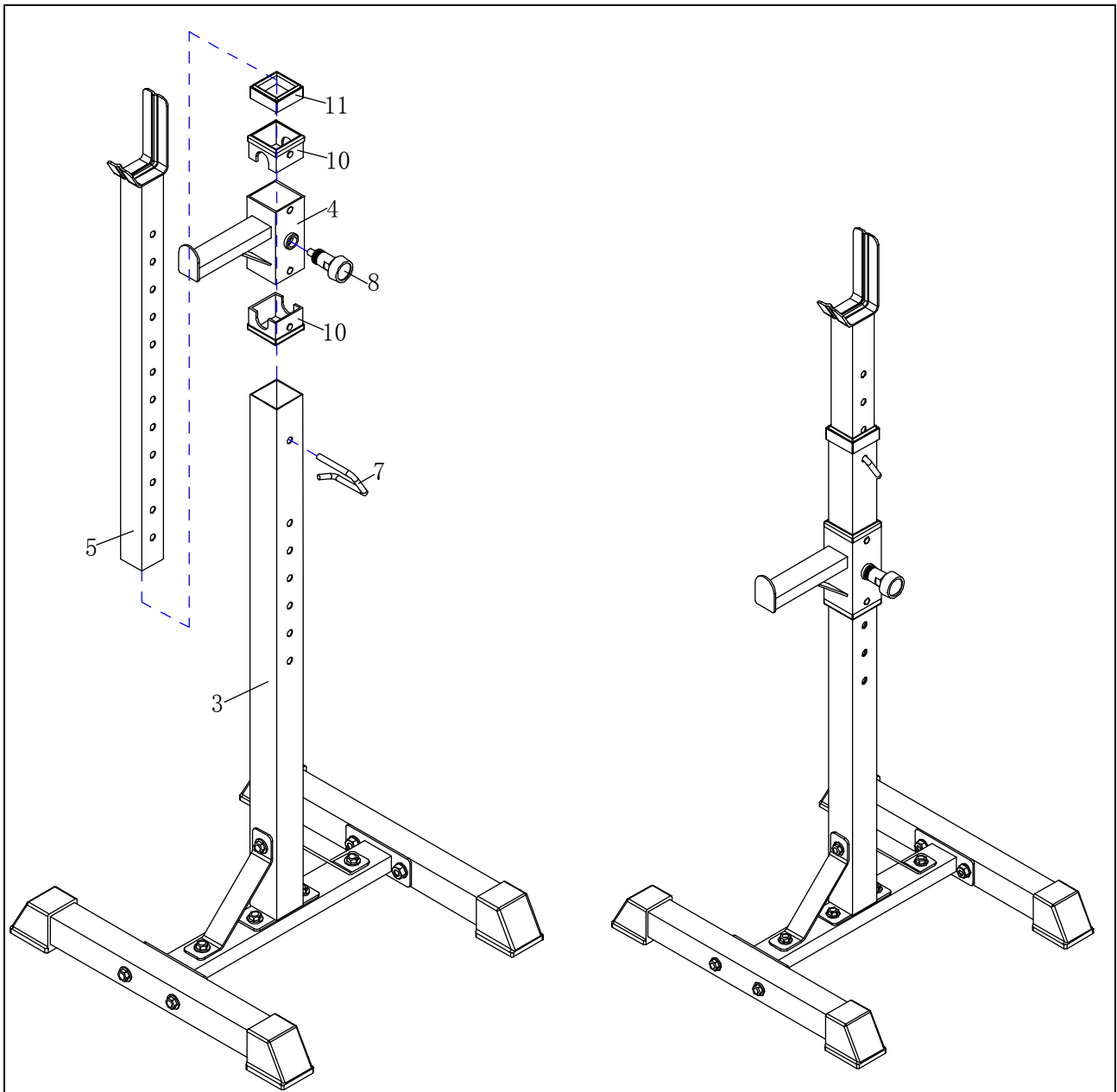

#### Assembly of the support tube

- 1) Insert the adjustable tube(4) into the stand tube(3), locked with quick pin(8).then put the 60x50 mid-empty plug(11) onto the stand tube(3).
- 2) Insert the support tube(5) into the stand tube(3), locked with safety pin(7).

US



001-877-644-9366  
customerservice@aosom.com

CA



001-855-537-6088  
customerservice@aosom.ca

UK



0044-800-240-4004  
enquiries@mhstar.co.uk

DE



0049-(0)40-88307530  
service@aosom.de

FR



0033-1-84166106  
contact@aosom.fr

ES



0034-931294512  
atencioncliente@aosom.es

IT



0039-0249471447  
clienti@aosom.it