



INafc008V01_CA_UK_FR_ES_DE_IT

A20-082



IMPORTANT, RETAIN FOR FUTURE REFERENCE: READ CAREFULLY

ASSEMBLY INSTRUCTION



- 1. 180ml water will be pumped out continuously by one step.
- 2. 19L fresh water tank, 3L liquid soap tank.
- 3. More than 100 washes by a single fill-up.
- 4. 1ml liquid soap dispenser included.
- 5. Equipped with multipurpose towel rack.
- 6. Equipped with wheels for moving.
- 7. Equipped with flexible hose for draining.



- 1. Please always assemble according to the instruction.
- 2. Base tank can be fixed on ground through four holes at the corner if necessary.



1 Screw the stand column in the base tank.

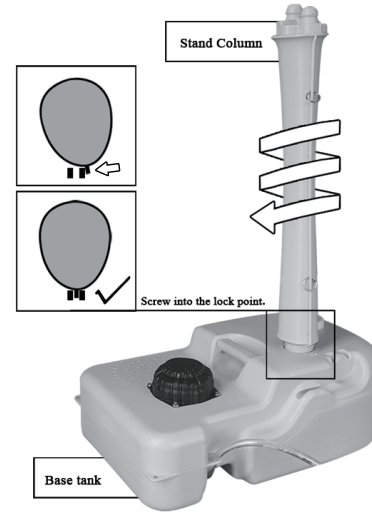

2 Assemble the washbasin on the top of the stand column.

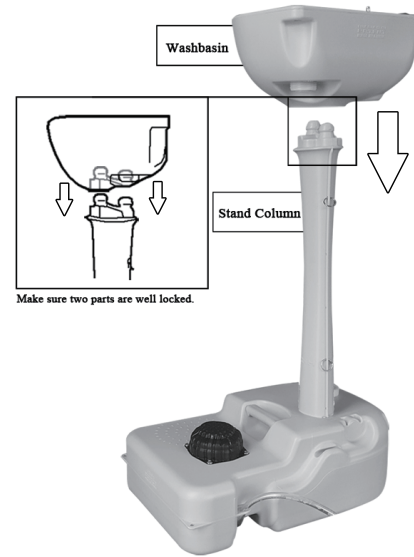

3 Insert faucet into transparent tube and fix it on the washbasin, then fix the tube with base tank and stand column.

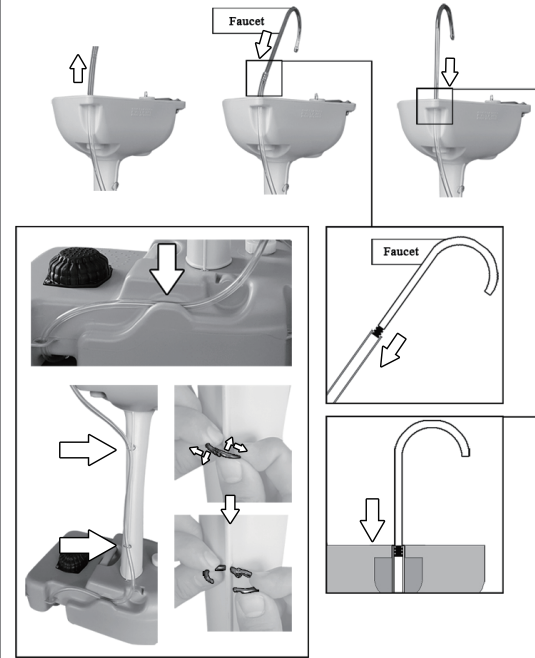

4 Fill the liquid soap into the tank and assemble the dispenser.



5 Screw the flexible drain hose on the washbasin.

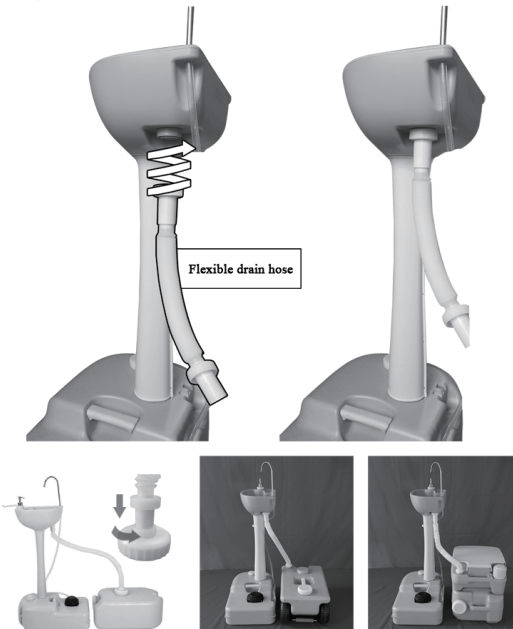

Demonstration only, water tank and portable toilet are not included.

6 Fill fresh water into base tank and step foot pump for handwash.

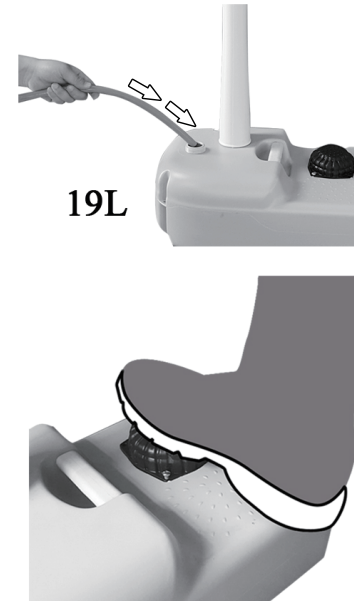

Equipped with multipurpose towel rack

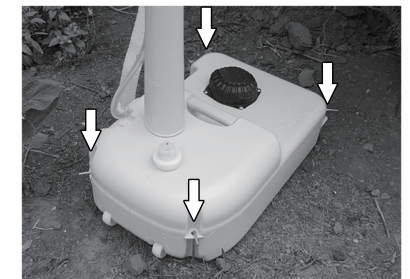

Base tank can be fixed on ground through four holes at the corner if necessary
Pegs are sold separately, not included.



1. 180ml d'eau sera pompée en continu par une seule étape.
2. Réservoir d'eau douce de 19L, réservoir de savon liquide de 3L.
3. Plus de 100 lavages par un seul remplissage.
4. Distributeur de savon liquide de 1 ml inclus.
5. Équipé de porte-serviettes polyvalent.
6. Équipé de roues pour le déplacement.
7. Équipé d'un flexible de vidange.



1. Veuillez toujours assembler conformément aux instructions.
2. Le réservoir de base peut être fixé sur le sol à travers quatre trous au coin si nécessaire.



1 Assemblez le lavabo sur le dessus de la colonne de support.

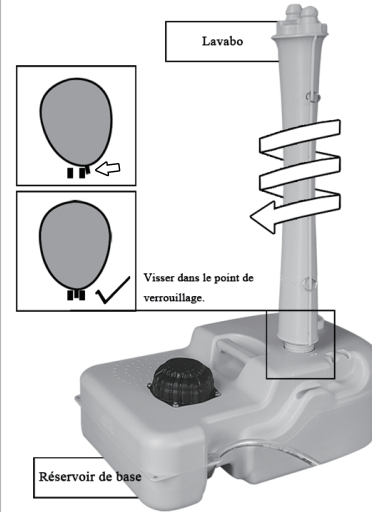

2 Assemblez le lavabo sur le dessus de la colonne de support.

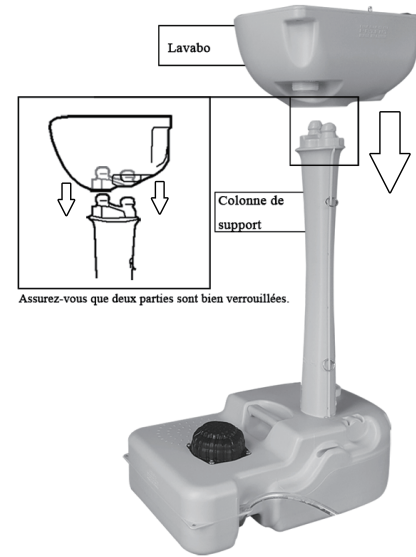

3 Insérez le robinet dans un tube transparent et fixez-le sur le lavabo, puis fixez le tube avec réservoir de base et la colonne de support.

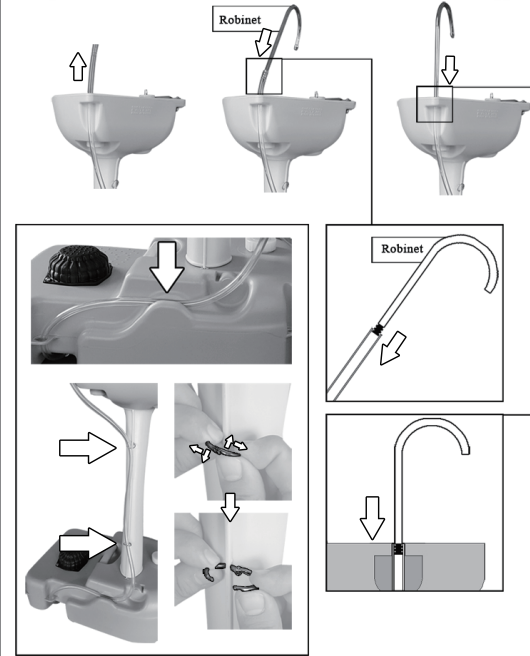

4 Remplissez d'eau fraîche le réservoir de base et marchez sur la pompe au pied pour le lavage à la main.



5 Vissez le flexible de vidange sur le lavabo.

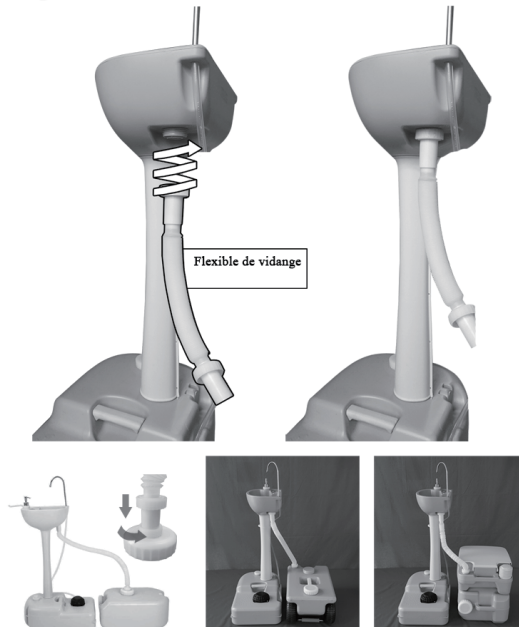

6 Remplissez l'eau douce dans le réservoir de base et marchez sur la pompe au pied pour le lavage des mains.

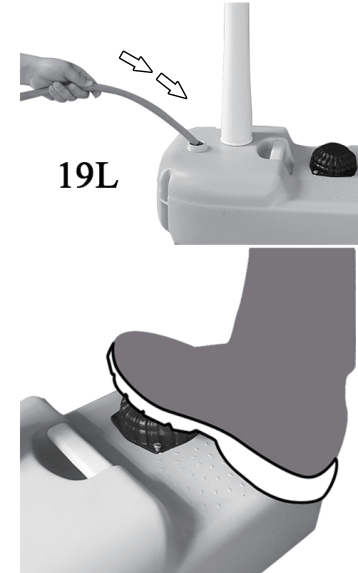

Équipé d'un support à serviettes polyvalent

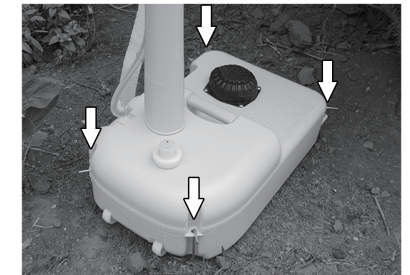

Le réservoir de base peut être fixé au sol à travers quatre trous au coin si nécessaire. Les chevilles sont vendues séparément, non inclus.

ES



1. 180 ml de agua se bombeará de forma continua por un paso.
2. Tanque de agua fresco de 19L, tanque de jabón líquido de 3L.
3. Más de 100 lavados si se llena de una vez.
4. Dispensador de jabón líquido de 1 ml incluido.
5. Equipado con toallero multiuso.
6. Equipado con ruedas para mover.
7. Equipado con manguera flexible para drenaje.



1. Por favor, ensamble siempre según las instrucciones.
2. El tanque de base puede ser fijado en el suelo por cuatro agujeros en la esquina si es necesario.



1 Atornille la columna de soporte en el tanque de base.

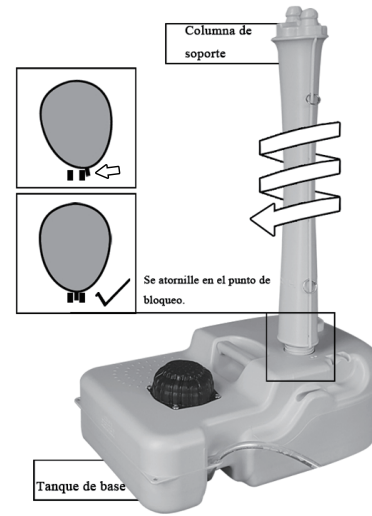

2 Ensamble el lavabo en la parte superior de la columna del soporte.

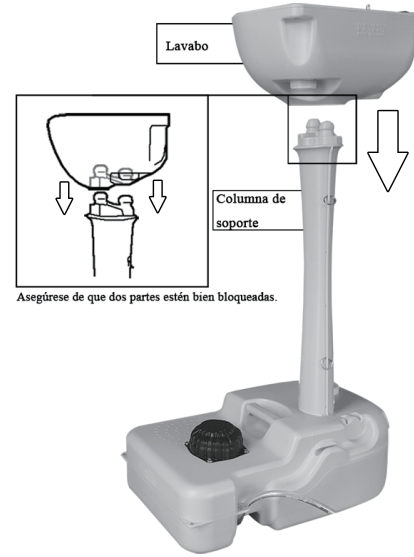

3 Inserte el grifo en el tubo transparente y fíjelo en el lavabo, luego fije el tubo con el tanque de base y la columna de soporte.

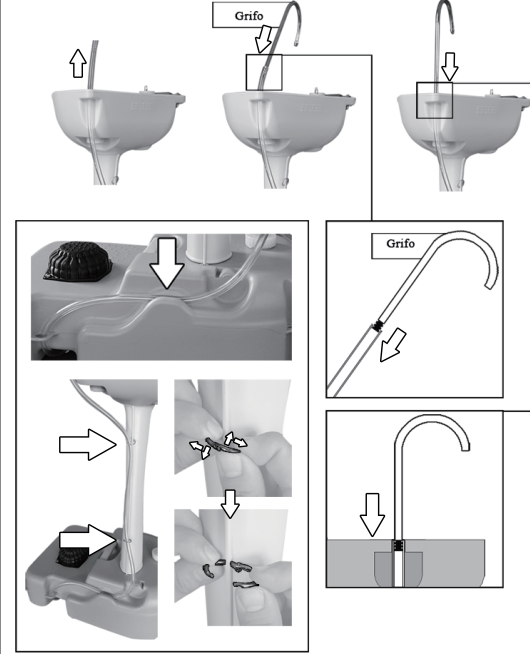

4 Llene agua fresca en el tanque de base y la bomba inferior para lavar las manos.



5 Atornille la manguera de drenaje flexible en el lavabo.

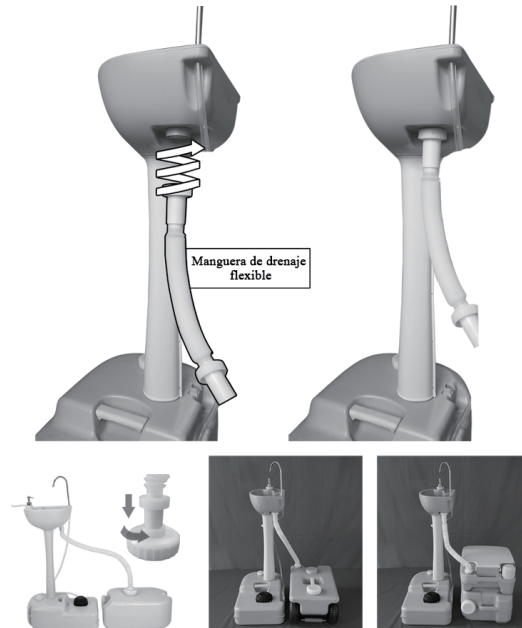

La sola demostración, el tanque de agua y baño portátil no están incluidos.

6 Llene agua fresca en el tanque de base y la bomba inferior para lavar las manos.

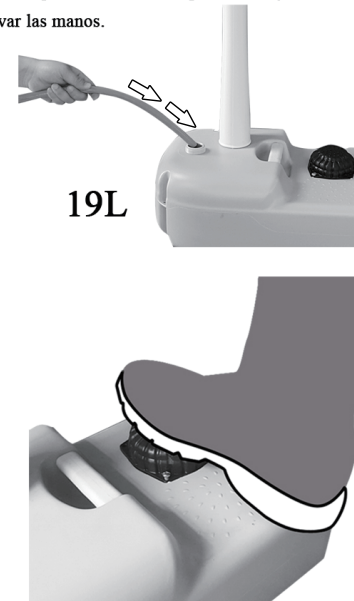

Equipado con toallero multiuso

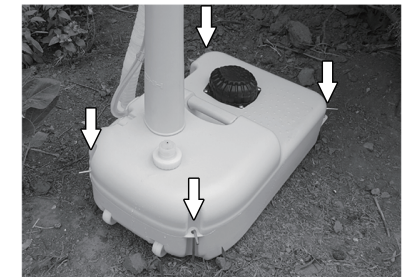

El tanque de base puede ser fijado en el suelo a través de cuatro agujeros en la esquina si es necesario

Las clavijas se venden por separado, no están incluidas.

DE



- 1. 180 ml Wasser werden kontinuierlich in einem Schritt abgepumpt.
- 2. 19 l Frischwassertank, 3 l Flüssigseifentank.
- 3. Mehr als 100 Wäschen durch einmaliges Auffüllen.
- 4. 1 l Flüssigseifenspender enthalten
- 5. Ausgestattet mit einem Mehrzweck-Handtuchhalter.
- 6. Ausgestattet mit Rädern zum Bewegen.
- 7. Ausgestattet mit einem flexiblen Schlauch zum Ablassen.



- 1. Bitte montieren Sie immer gemäß den Anweisungen.
- 2. Der Grundtank kann bei Bedarf durch vier Löcher an der Ecke am Boden befestigt werden.



1 Schrauben Sie die Standsäule in den Grundtank.

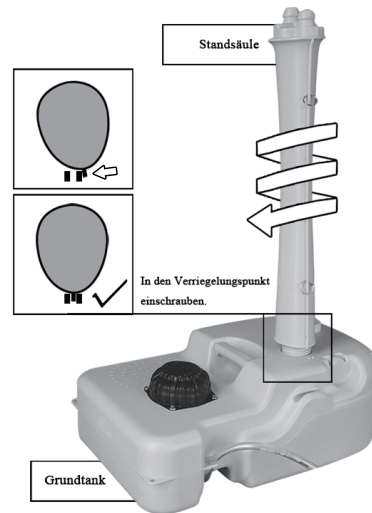

2 Montieren Sie das Waschbecken oben auf der Standsäule.

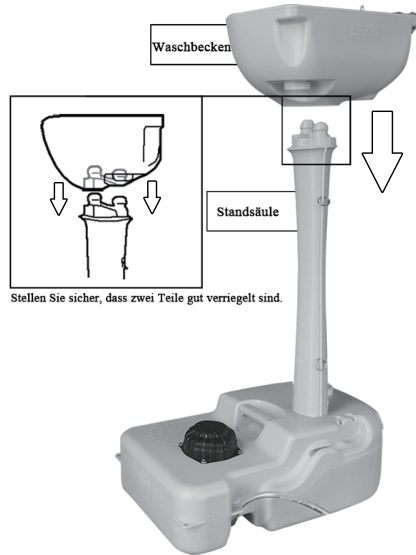

3 Setzen Sie den Wasserhahn in das transparente Rohr ein und befestigen Sie ihn am Waschbecken. Befestigen Sie das Rohr dann mit dem Grundtank und der Standsäule.

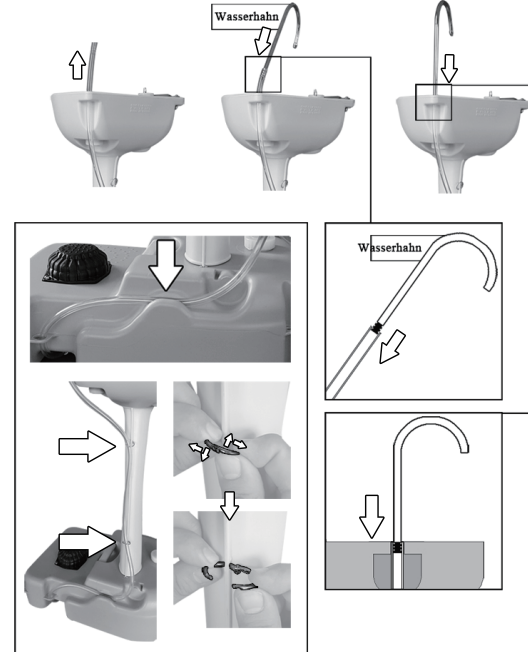

4 Füllen Sie frisches Wasser in den Grundtank und stellen Sie die Fußpumpe zum Händewaschen auf.



5 Schrauben Sie den flexiblen Ablaufschlauch am Waschbecken fest.

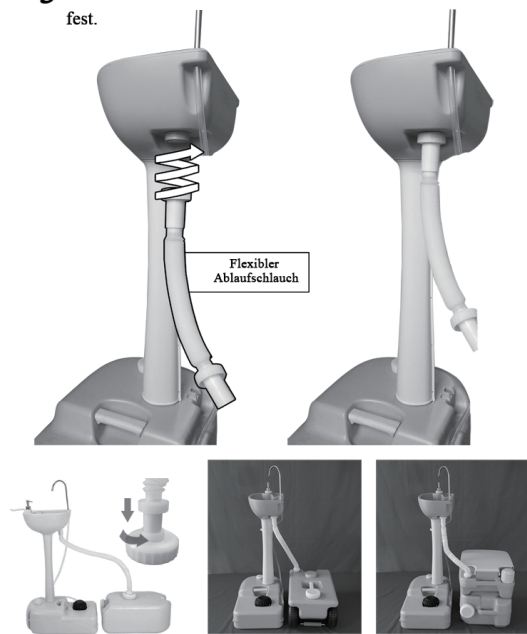

Nur zur Demonstration, Wassertank und tragbare Toilette sind nicht enthalten.

6 Füllen Sie frisches Wasser in den Grundtank und stellen Sie die Fußpumpe zum Händewaschen auf.

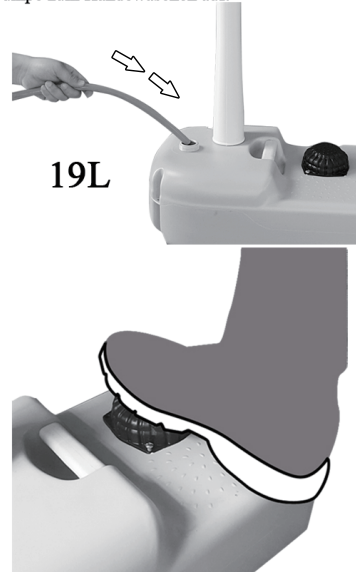

Ausgestattet mit Mehrzweck-Handtuchhalter

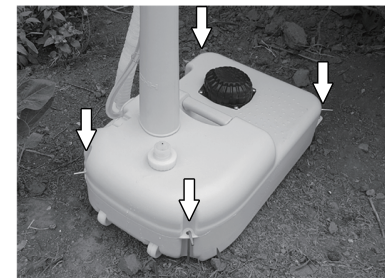

Der Grundtank kann bei Bedarf durch vier Löcher an der Ecke am Boden befestigt werden
Die Stifte sind separat erhältlich und nicht im Lieferumfang enthalten.



1. 180 ml di acqua verranno pompate continuamente.
2. Serbatoio di acqua dolce da 2,19 litri, serbatoio di sapone liquido da 3 litri.
3. Più di 100 lavaggi con un solo riempimento.
4. Dispenser di sapone liquido da 4,1 ml incluso.
5. Dotato di portasciugamani multiuso.
6. Dotato di ruote per lo spostamento.
7. Dotato di tubo flessibile per lo scarico.



1. Si prega di assemblare sempre secondo le istruzioni.
2. Il serbatoio di base può essere fissato a terra con quattro fori all'angolo, se necessario.



- 1** Avvitare la colonna del supporto nel serbatoio di base.

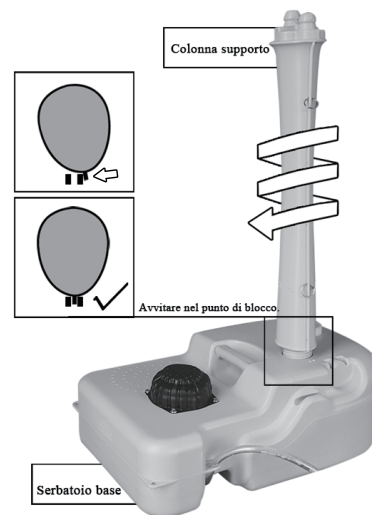

- 2** Montare il lavabo sulla parte superiore della colonna del supporto.

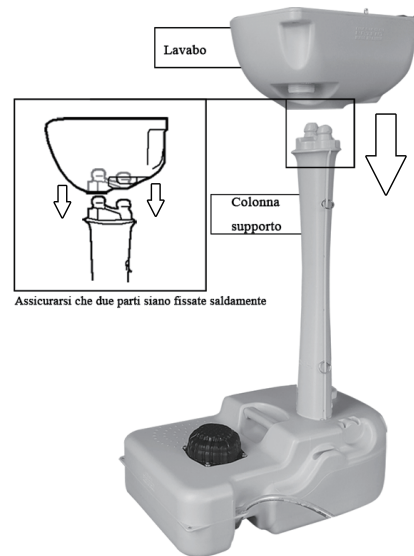

- 3** Inserire il rubinetto nel tubo trasparente e fissarlo sul lavandino, quindi fissare il tubo con il serbatoio di base e la colonna di supporto.

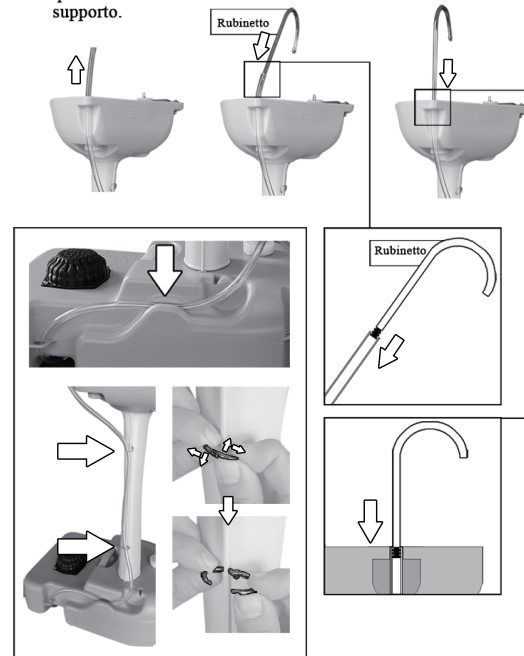

- 4** Riempire d'acqua fresca nel serbatoio alla base e pompare a pedale per il lavaggio a mano.



- 5** Avvitare il tubo flessibile di scarico sul lavandino.

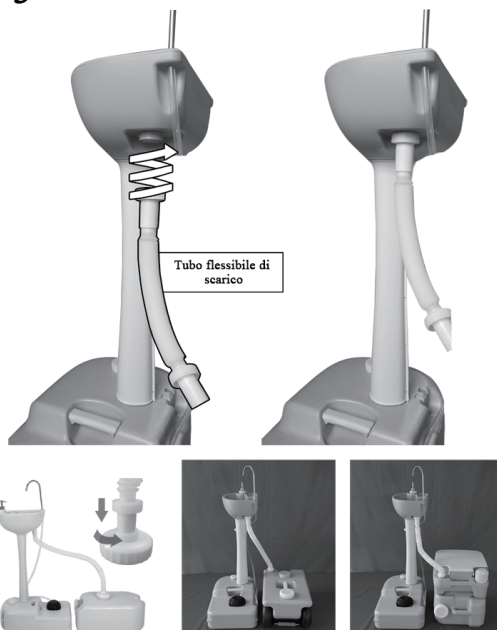

Solo per dimostrazione, serbatoio dell'acqua e servizi igienici portatili non sono inclusi.

- 6** Riempire d'acqua fresca nel serbatoio di base e pompare a pedale per il lavaggio a mano.

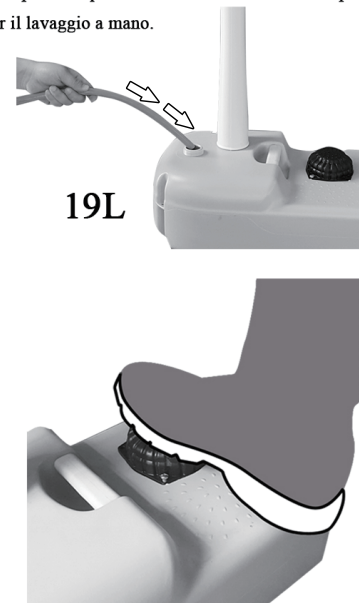

Dotato di portasciugamani multiuso

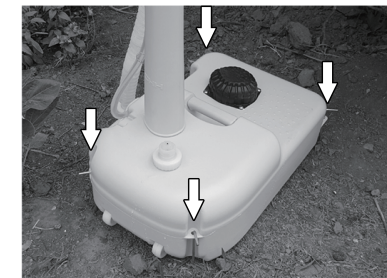

Il serbatoio di base può essere fissato a terra attraverso quattro fori all'arrivo, se necessario.

I pioli sono venduti separatamente, non inclusi.