

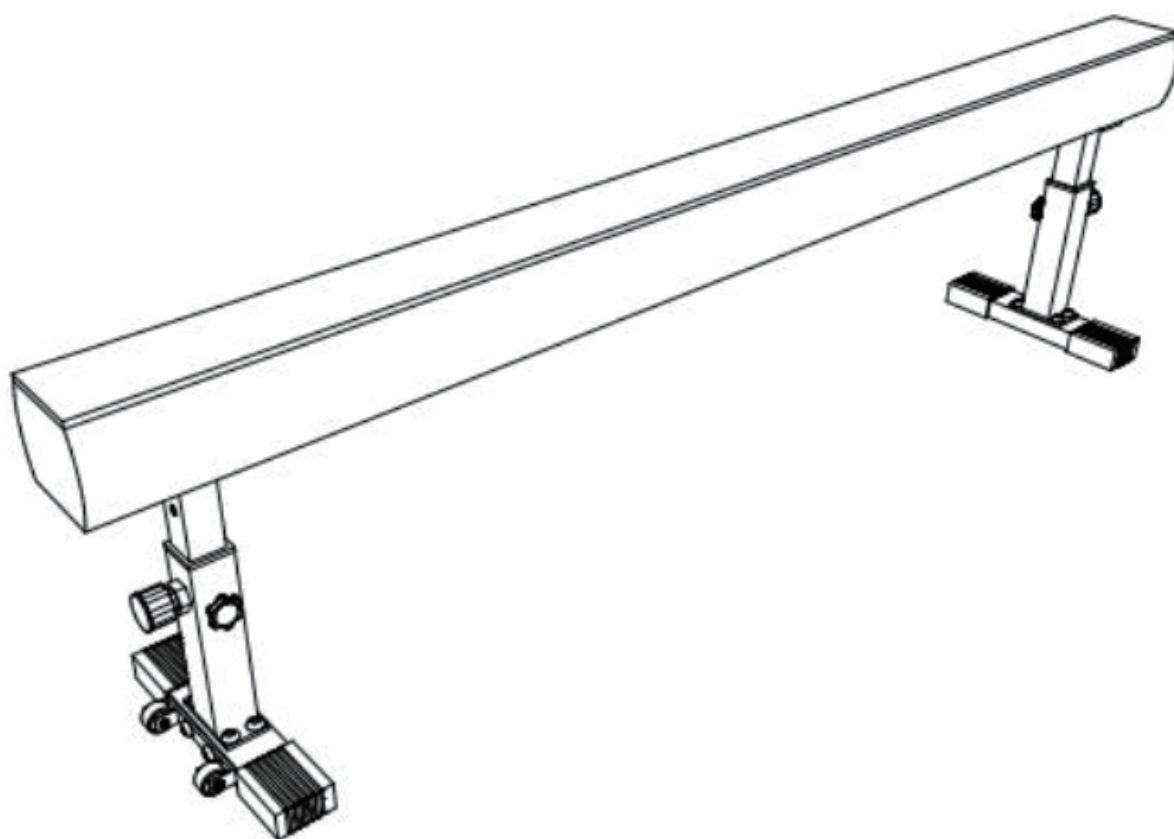

INah009\_UK\_FR\_ES\_DE\_IT

**A50-009V00**



**EN\_** IMPORTANT, RETAIN FOR FUTURE REFERENCE: READ CAREFULLY.

**FR\_** IMPORTANT: A LIRE ATTENTIVEMENT ET À CONSERVER POUR CONSULTATION ULTÉRIEURE.

**ES\_** IMPORTANTE, LEA Y GUARDE PARA FUTURAS REFERENCIAS.

**DE\_**, WICHTIG! SORGFÄLTIG LESEN UND FÜR SPÄTER NACHSCHLAGEN AUFBEWAHREN."

**IT\_** IMPORTANTE! CONSERVARE IL PRESENTE MANUALE PER FUTURO RIFERIMENTO E LEGGERLO ATTENTAMENTE.

## EN

---

1. Misuse and abuse of this product can cause serious injury.
2. Read the instructions before using the product.
3. Inspect before use and replace worn, defective or missing parts.
4. Only allowed for adults to install and be used by adults'supervision.
5. Place it on a flat surface,check all the parts are well connected before use.
6. Product for Age: 6+ years old.
7. Only for domestic use.
8. Maximum total weight 60KG

## FR

---

1. L'utilisation incorrecte et abusive de ce produit peut occasionner des blessures graves.
2. Lisez les instructions avant d'utiliser le produit.
3. Inspectez avant l'utilisation et remplacez les pièces usées, défectueuses ou manquantes.
4. Installation exclusivement réservée aux adultes et utilisation sous la surveillance d'adultes.
5. Placez-le sur une surface plane, vérifiez que toutes les pièces sont bien connectées avant de l'utiliser.
6. Recommandé pour les enfants de 6 ans et plus.
7. À usage domestique uniquement.
8. Poids total maximum 60KG

## ES

---

1. El mal uso y el abuso de este producto pueden causar lesiones graves.
2. Lea las instrucciones antes de utilizar el producto.
3. Inspeccione el producto antes de utilizarlo y sustituya las piezas desgastadas, defectuosas o que falten.
4. Sólo se permite la instalación por parte de adultos y su uso debe ser supervisado por adultos.
5. Colóquelo en una superficie plana y compruebe que todas las piezas están bien conectadas antes de usarlo.
6. Producto para la edad: 6+ años.
7. Sólo para uso doméstico.
8. Carga máxima total 60KG

1. Fehlgebrauch und Missbrauch dieses Produkts können zu schweren Verletzungen führen.
2. Lesen Sie die Anweisungen, bevor Sie das Produkt benutzen.
3. Überprüfen Sie es vor dem Gebrauch und ersetzen Sie abgenutzte, defekte oder fehlende Teile.
4. Nur von Erwachsenen zu installieren und unter Aufsicht von Erwachsenen zu verwenden.
5. Legen Sie es auf eine flache Oberfläche, überprüfen Sie, ob alle Teile gut verbunden sind, bevor Sie es verwenden.
6. Produkt für Alter: 6+ Jahre alt.
7. Nur für den Hausgebrauch.
8. Maximales Gesamtgewicht 60 kg

1. L'uso improprio e l'abuso di questo prodotto possono causare lesioni personali gravi.
2. Leggere le istruzioni prima dell'uso.
3. Ispezionare prima dell'uso e sostituire eventuali parti usurate, difettose o mancanti.
4. L'installazione deve essere eseguita solo da adulti e deve essere utilizzato sotto la supervisione di adulti.
5. Posizionare su una superficie piana, controllare che tutte le parti collegate saldamente prima dell'uso.
6. Età adatta: 6+ anni.
7. Solo per uso domestico.
8. Carico totale massimo 60 kg

**PARTS**

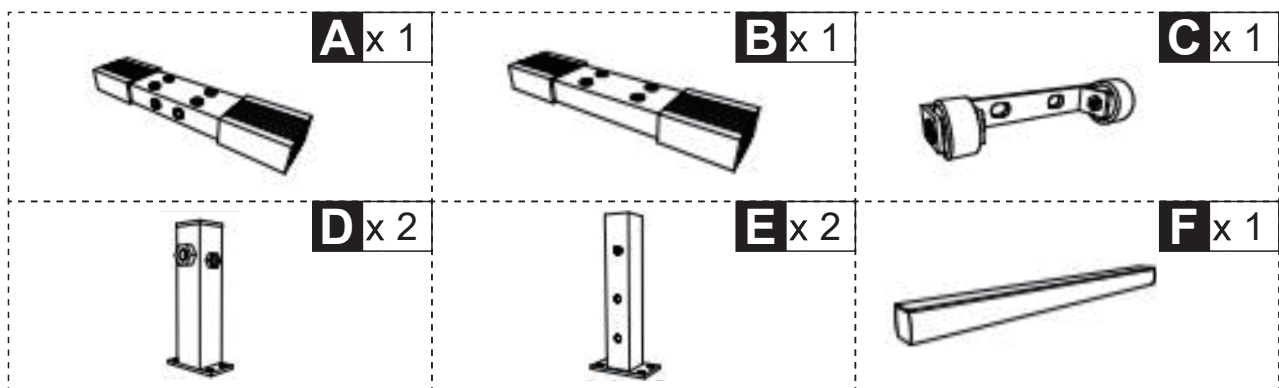

**HARDWARE**

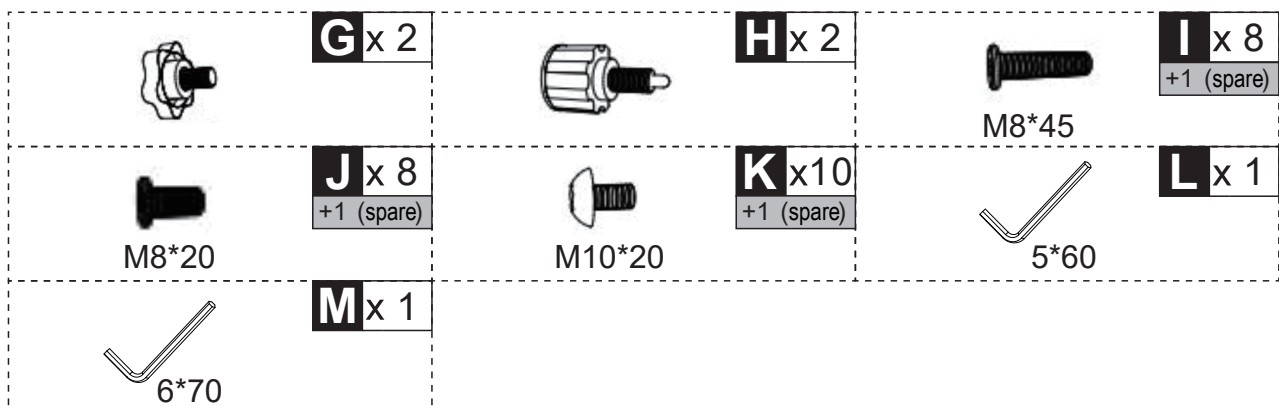

**TYPE A**

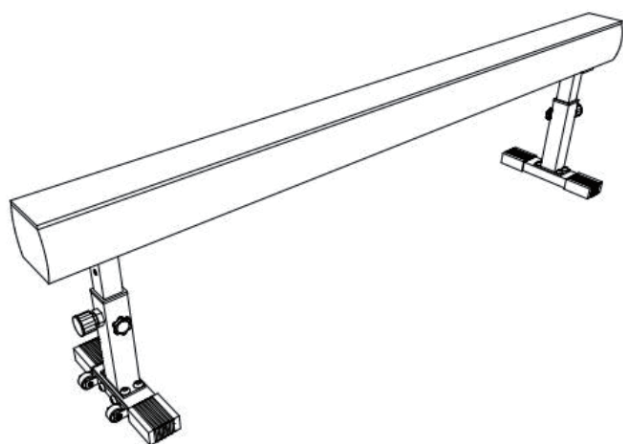

Page 5-6

**TYPE B**

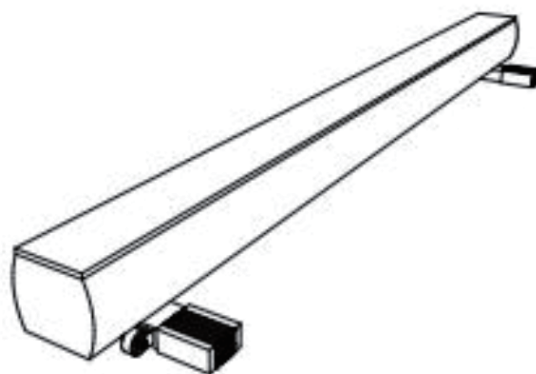

Page 7

**K** x 2

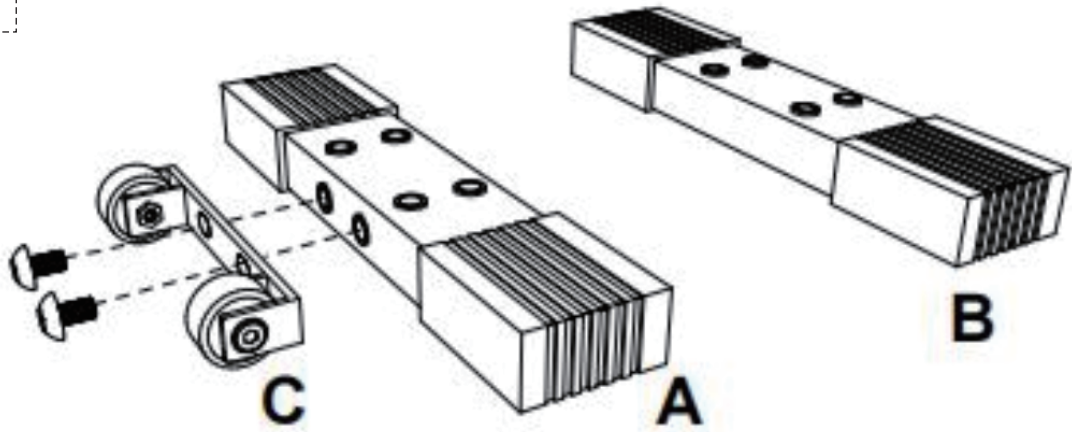

**K** x 8

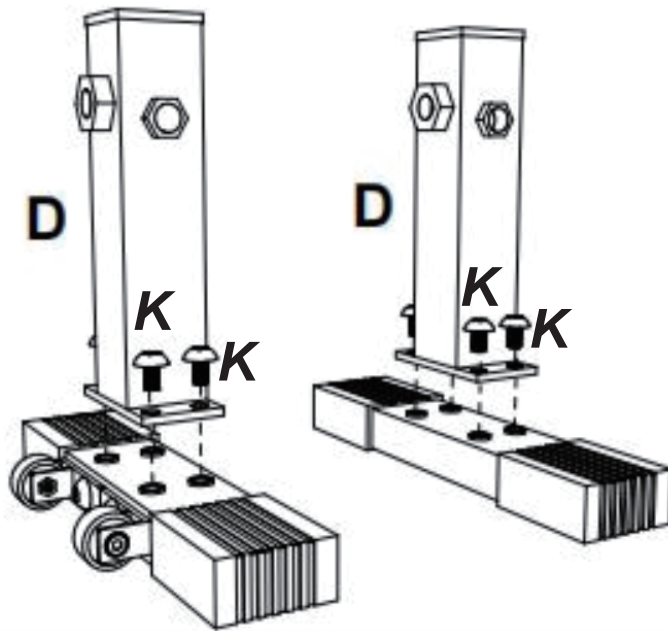

**G** x 2



**H** x 2

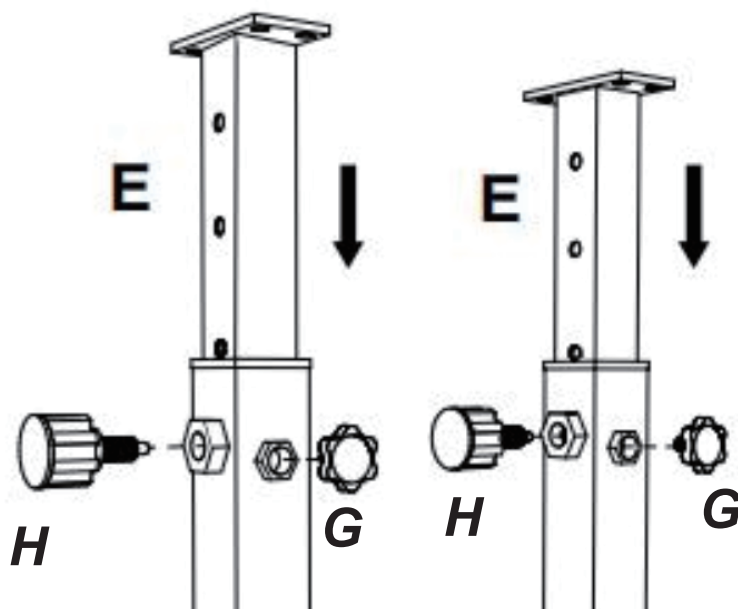

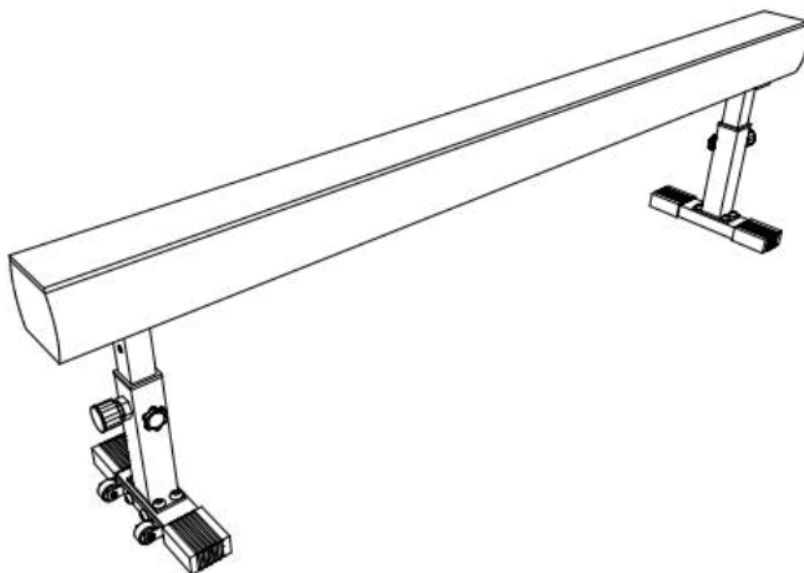
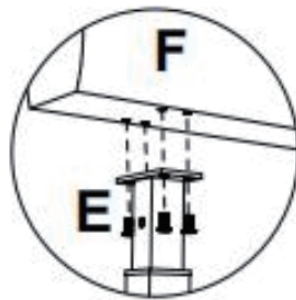
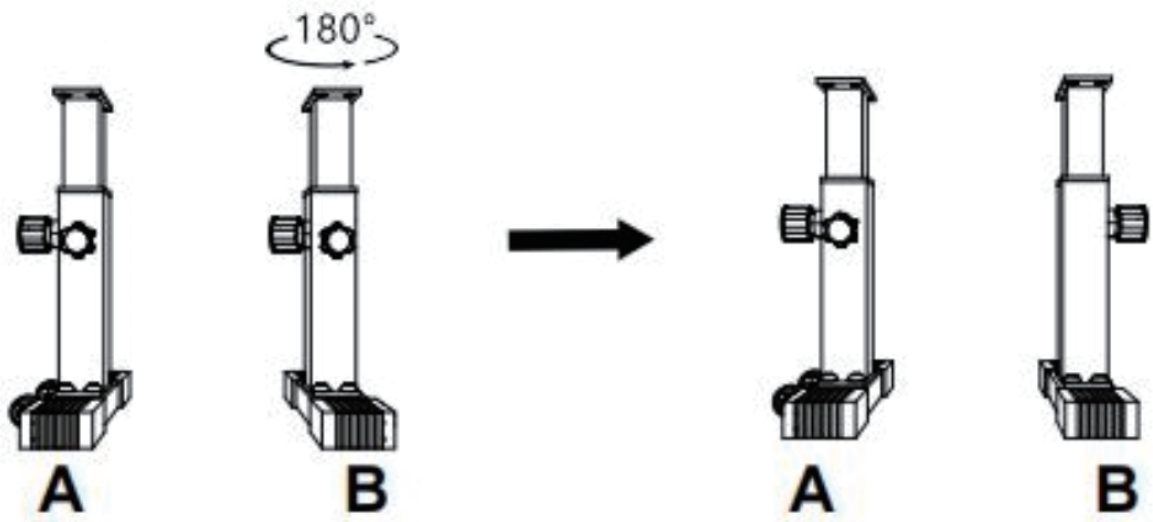

K x 2

M10\*20

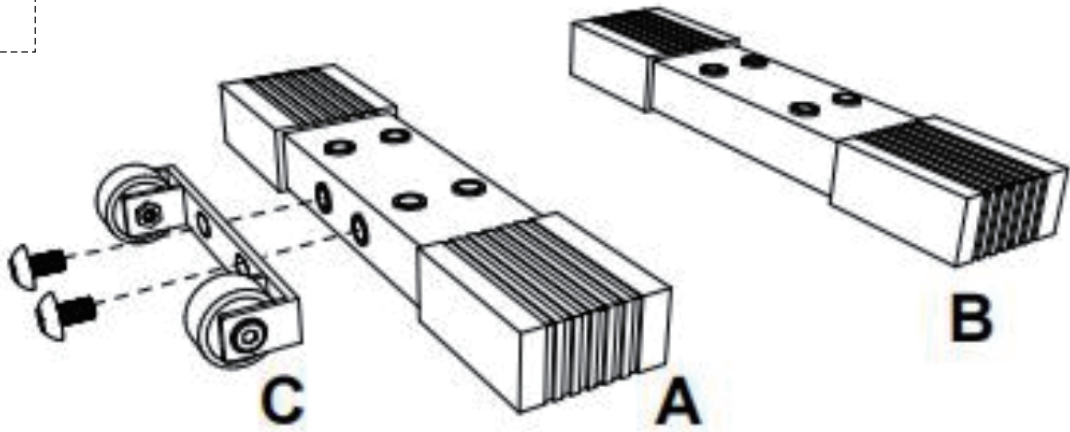

L x 8

M8\*45

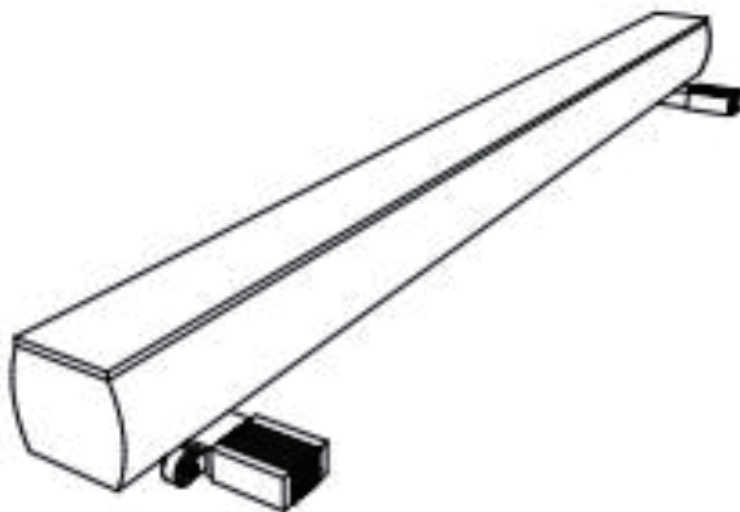
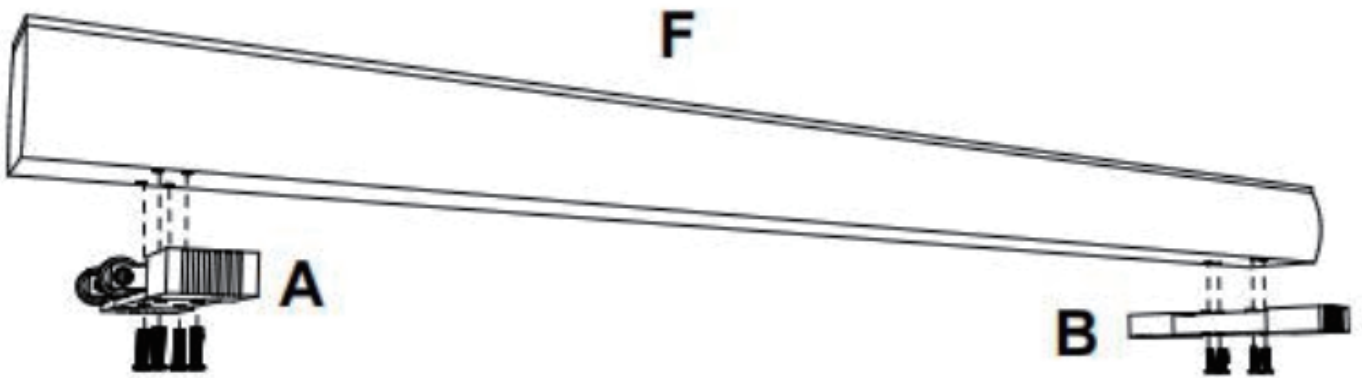

**IMPORTER ADDRESS****EN**

MH STAR UK LTD  
Unit 27, Perivale Park,  
Horsenden lane South  
Perivale, UB6 7RH  
MADE IN CHINA

**ADRESSE D'IMPORTATION****FR**

MH FRANCE  
2 Rue Maurice Hartmann  
92130 Issy Les Moulineaux  
France  
FABRIQUÉ EN CHINE

**IMPORTADOR****ES**

SPANISH AOSOM, S.L.  
C/ ROC GROS, Nº 15. 08550, ELS HOSTALET DE BALENYÀ, SPAIN.  
B66295775  
WWW.AOSOM.ES  
ATENCIONCLIENTE@AOSOM.ES  
TEL: 931294512  
HECHO EN CHINA

**ADRESSE DES IMPORTEUR****DE**

MH Handel GmbH  
Wendenstraße 309  
D-20537 Hamburg  
Germany  
IN CHINA HERGESTELLT

**IMPORTATO DA****IT**

AOSOM Italy srl  
Centro Direzionale Milanofiori  
Strada 1 Palazzo F1  
20057 Assago (MI)  
P.I.: 08567220960  
FATTO IN CINA