

Soozier

INalb001_US

A91-119V01



Weight Bench

READ AND SAVE THIS INSTRUCTION FOR FUTURE USE

ASSEMBLY INSTRUCTION

Parts list:

(1) Main body support
(1 piece with back cushion)

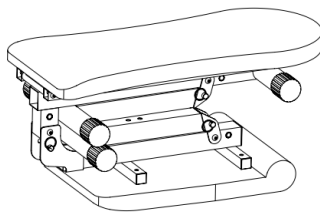

(2) Hook foot rod (1 piece)

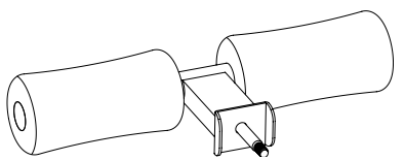

(A) Plastic handle nut (1 piece)

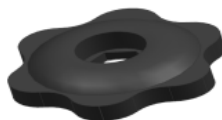

(B) M10 latch (3 pieces)

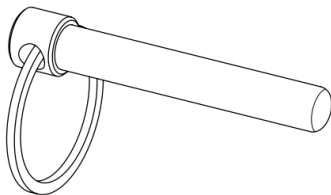

(C) M8 latch (1 piece)

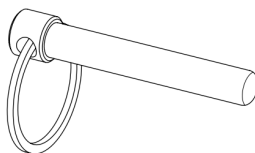

Disassembly diagram:

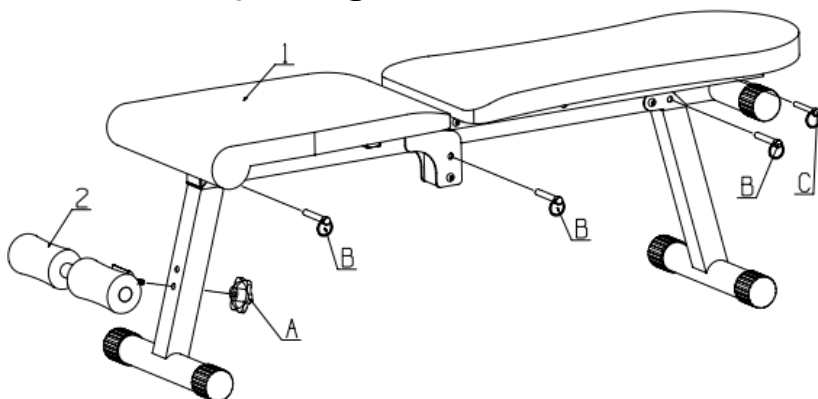

Step 1: Install the armrest rail and hook foot rail

1. First unfold (1) the main body support, align the holes of each component with the holes, and finally fix it with (B) M10 pins through the holes.

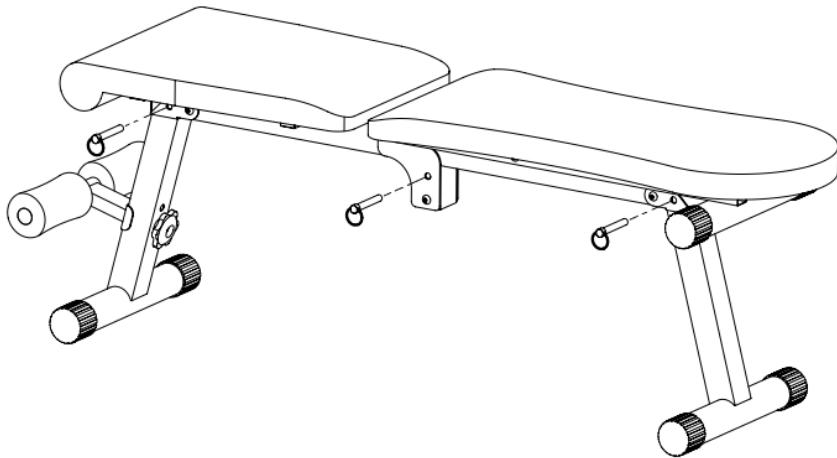

Step 2: Install the hook foot bar

1. Correspond (2) the hook-leg bolt with (1) the front support hole of the main body, and fasten it with (A) plastic handle nut. (Height of hook foot rod can be adjusted according to your own situation)

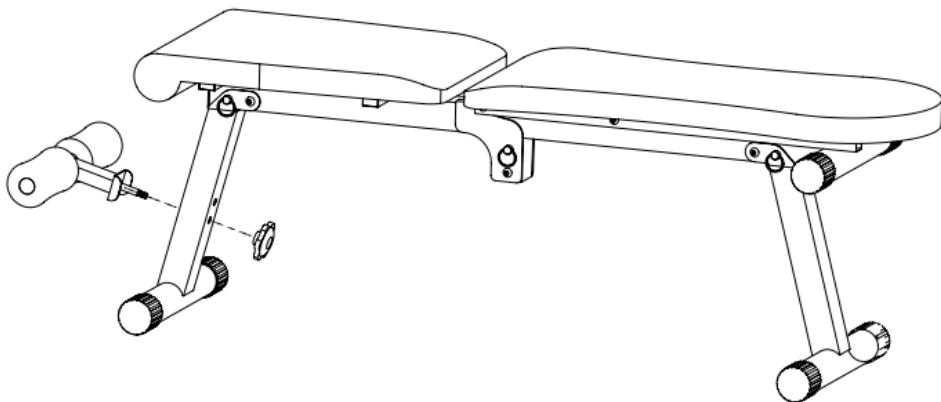

Back pad adjustment method of use:

1. Lift up the back cushion, adjust the angle of the back cushion according to your preference, pull out the (C) M8 pin from the pin placement hole, and insert the adjusted back cushion angle hole to fix it. (When the back pad is flat, the (C) M8 pin should be inserted into the pin placement hole to avoid losing the pin)

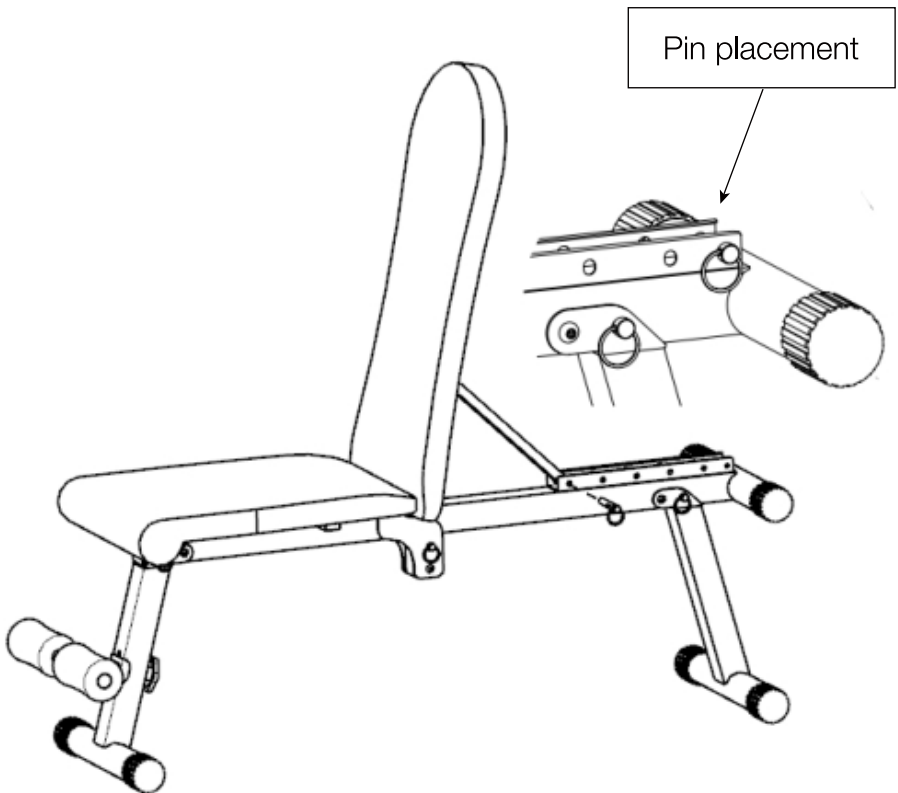



Installation complete: style reference diagram

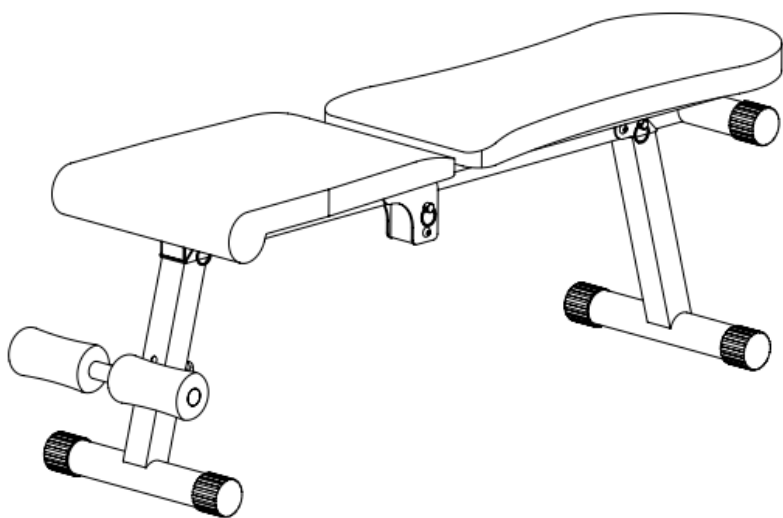

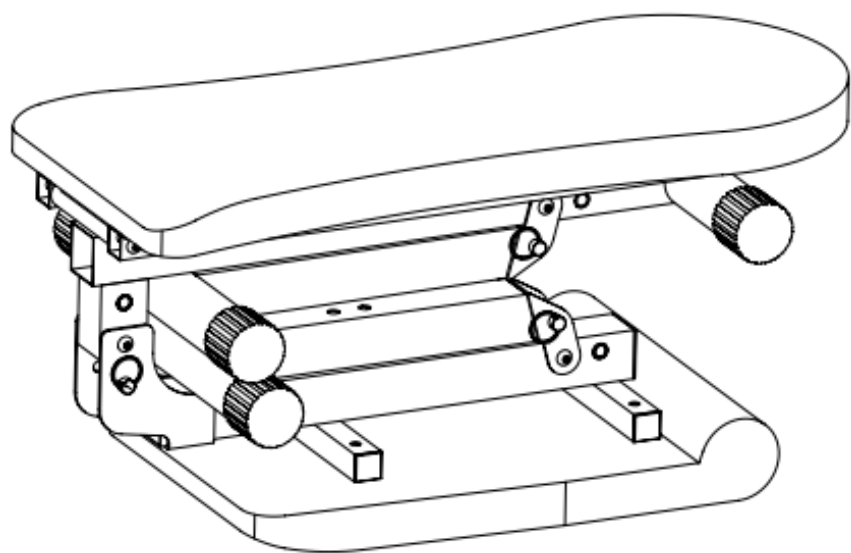
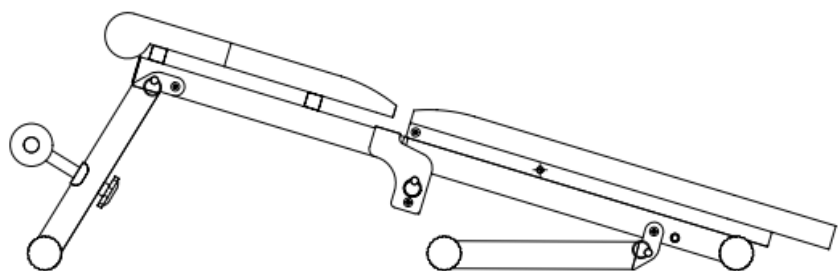

US



001-877-644-9366
customerservice@aosom.com

CA



001-855-537-6088
customerservice@aosom.ca

UK



0044-800-240-4004
enquiries@mhstar.co.uk

DE



0049-(0)40-88307530
service@aosom.de

FR



0033-1-84166106
contact@aosom.fr

ES



0034-931294512
atencioncliente@aosom.es

IT



0039-0249471447
clienti@aosom.it