

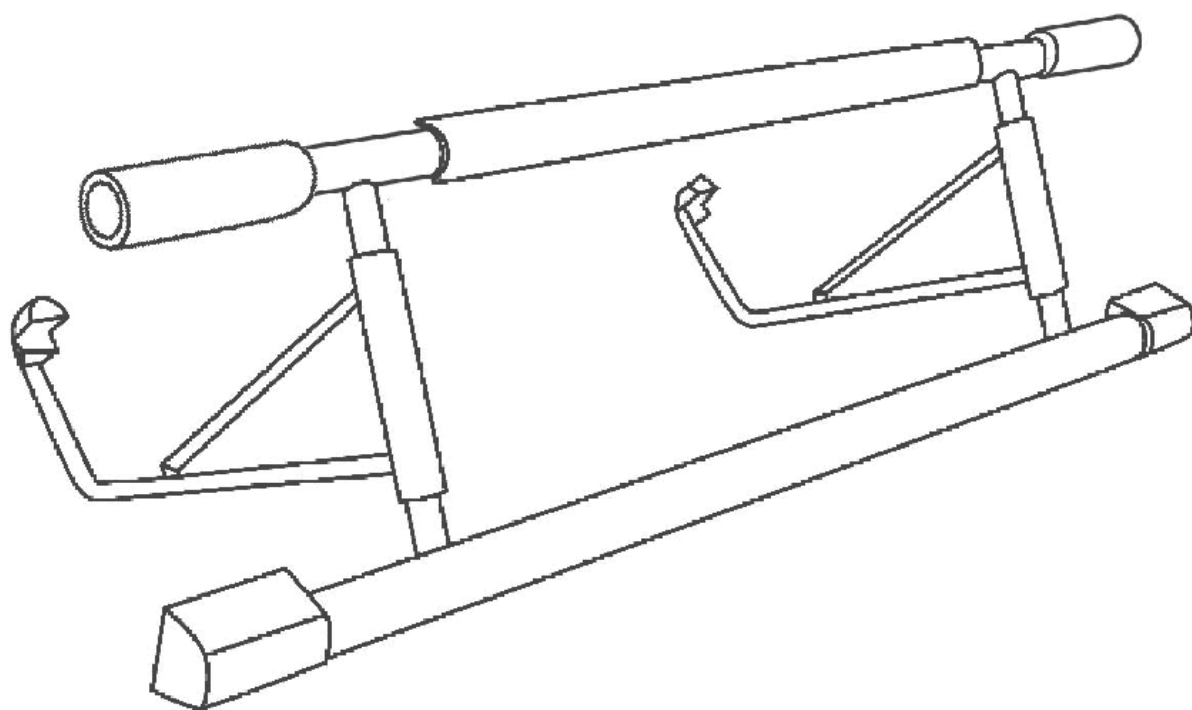

INalc003_IT_EN

A91-200



IMPORTANT, RETAIN FOR FUTURE REFERENCE: READ CAREFULLY

ASSEMBLY & INSTRUCTION MANUAL

GUIDA&NOTE

- * Assicurarsi che lo stipite della porta sia in buone condizioni e possa sopportare le sollecitazioni causate dall'utilizzo della barra per trazioni (non adatto per stipiti in cartongesso).
- * Installare la barra per trazioni solo su telai di porte con un'apertura compresa tra 75 e 95 cm (tra 30" e 37").
- * Allenarsi utilizzando solo la barra superiore.
- * Non allenarsi con la barra per trazioni vicino alle scale.
- * Non saltare per appendersi alla barra. Altrimenti potrebbe staccarsi o allentarsi dal suo ancoraggio alla porta.
- * Non appendersi per i piedi o per le gambe alla barra per trazioni.
- * Rimanere in posizione eretta ed eseguire un movimento controllato (non oscillante o a scatti) del corpo.
- * Non superare in nessun caso la capacità di carico massima di 100 kg.

LISTA PARTI

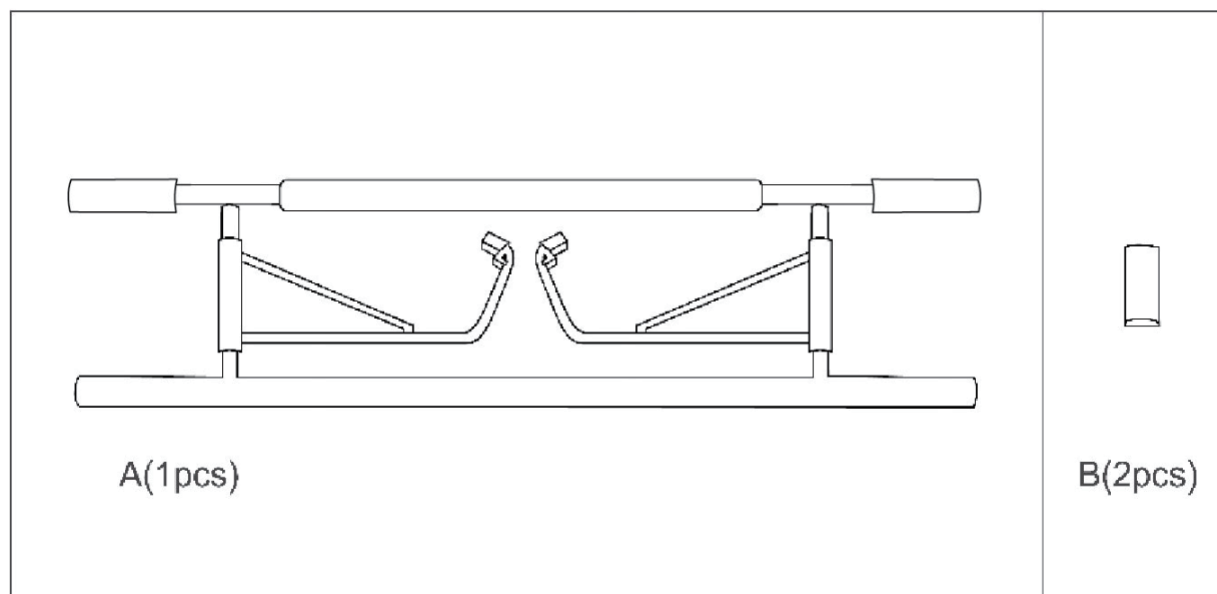

STEP DI ASSEMBLAGGIO

STEP 1

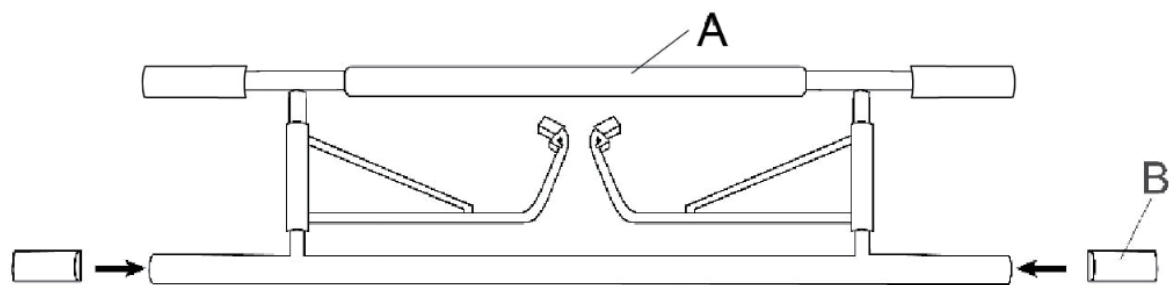

STEP 2

Aprire i ganci della porta. Questo assicura che i meccanismi di apertura funzionino correttamente. Quindi tirare entrambi i ganci della porta verso l'alto fino a entrambi sono in posizione verticale. (vedere la figura 2)

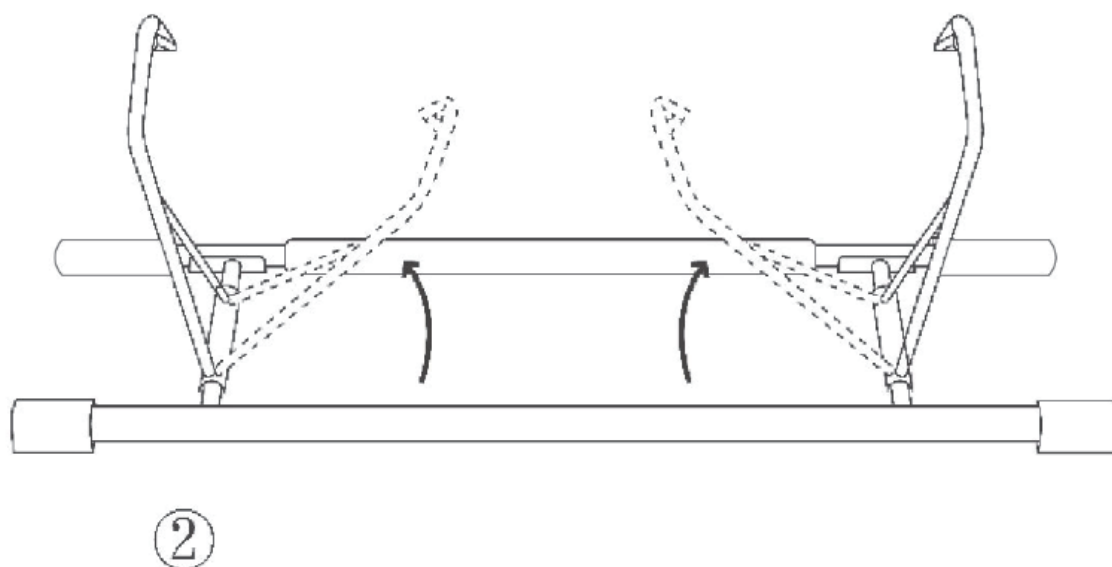

STEP 3

Fissare le guarnizioni di protezione del telaio della porta e verificare che siano connessi ai punti di contatto con il telaio.

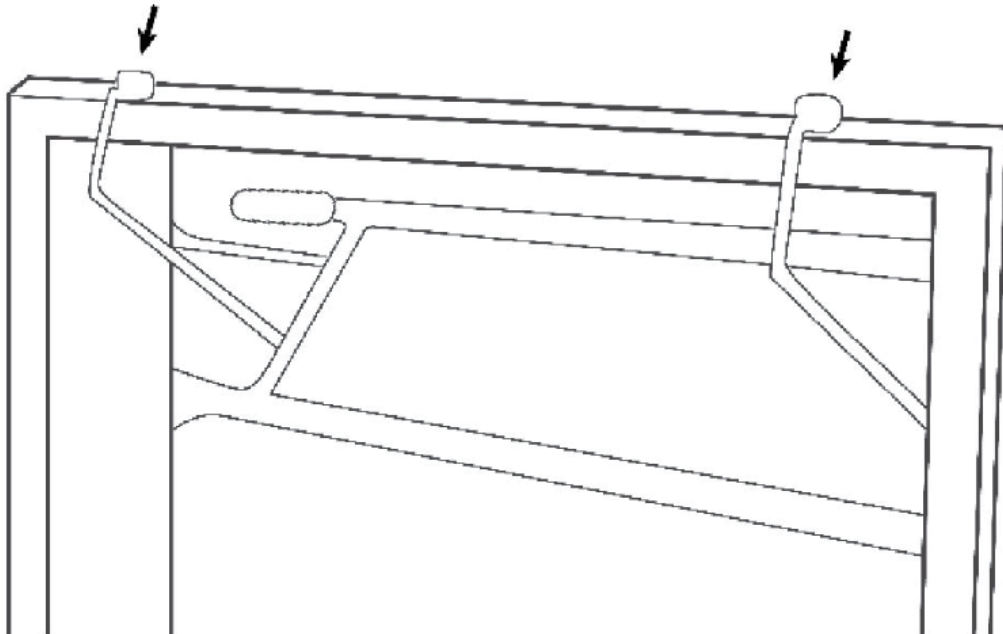

STEP 4

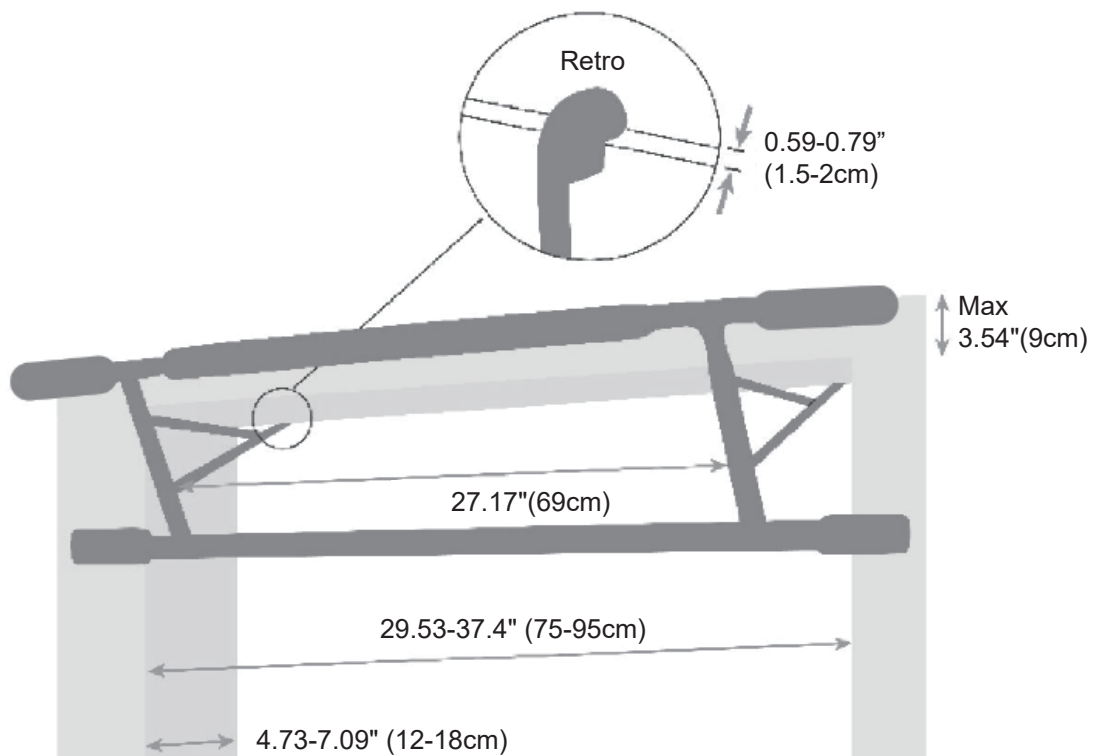

GUIDE&NOTES

- * Make sure the door frame is in good condition and can withstand the stresses caused by using the pull-up bar (it is not suitable for plasterboard frame)
- * Set up the pull up bar only on door frames with an opening between 75 and 95cm (between 30" and 37")
- * Use only the upper bar for performing the exercises
- * Do not use the pull up bar near stairs
- * Do not jump up to grab the bar. Because it may detach or loosen from its anchor.
- * Do not hang your feet or legs on the pull up bar
- * Remain in the upright position with controlled (not swinging or jerky) movement of your body
- * Do not exceed the maximum load capacity of 100 kg under any circumstances

PARTS LIST

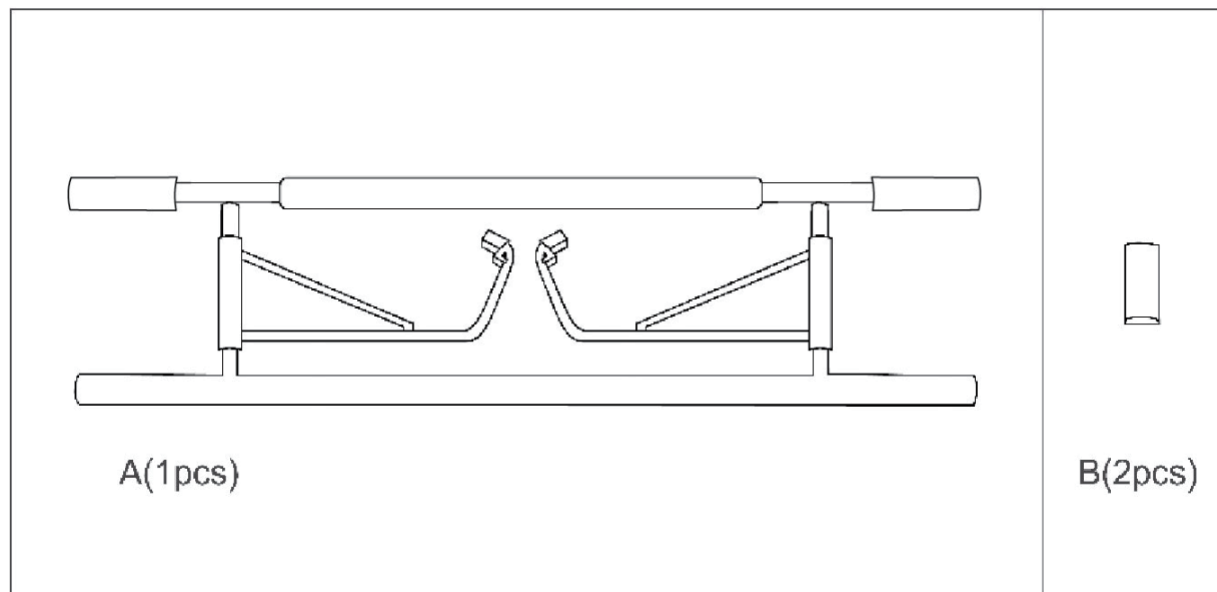

ASSEMBLY STEPS

STEP 1

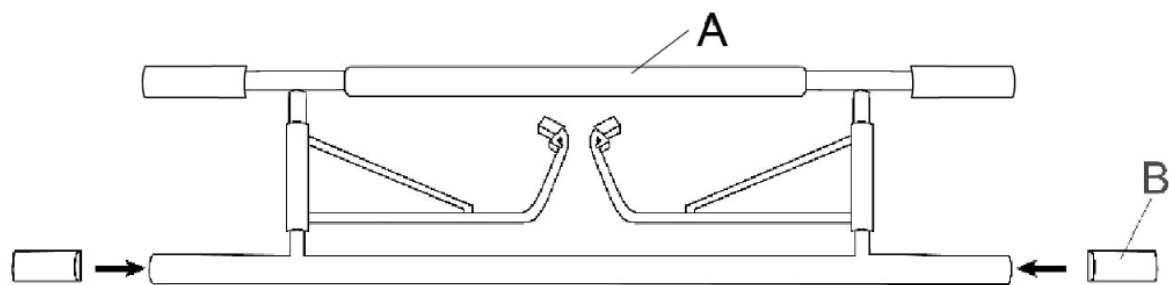

STEP 2

Open the door hooks. This makes sure the opening mechanisms functions without issues. Then pull both door hooks upward until both hooks are in vertical position. (- see image 2)

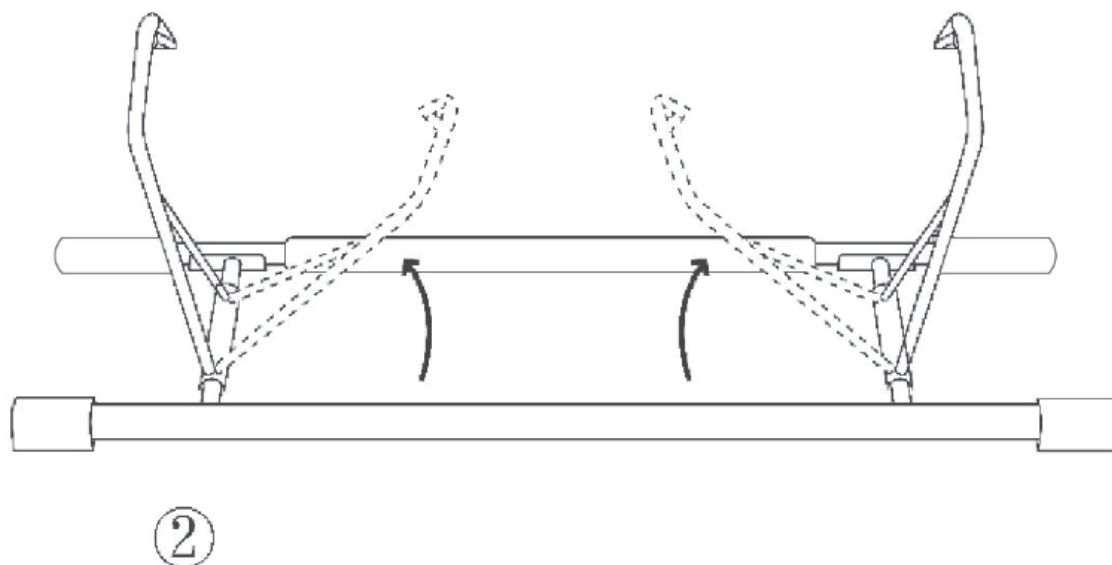

STEP 3

Put on the door frame protection blocks and Please check the points of contact with the door frame are in the connect position.

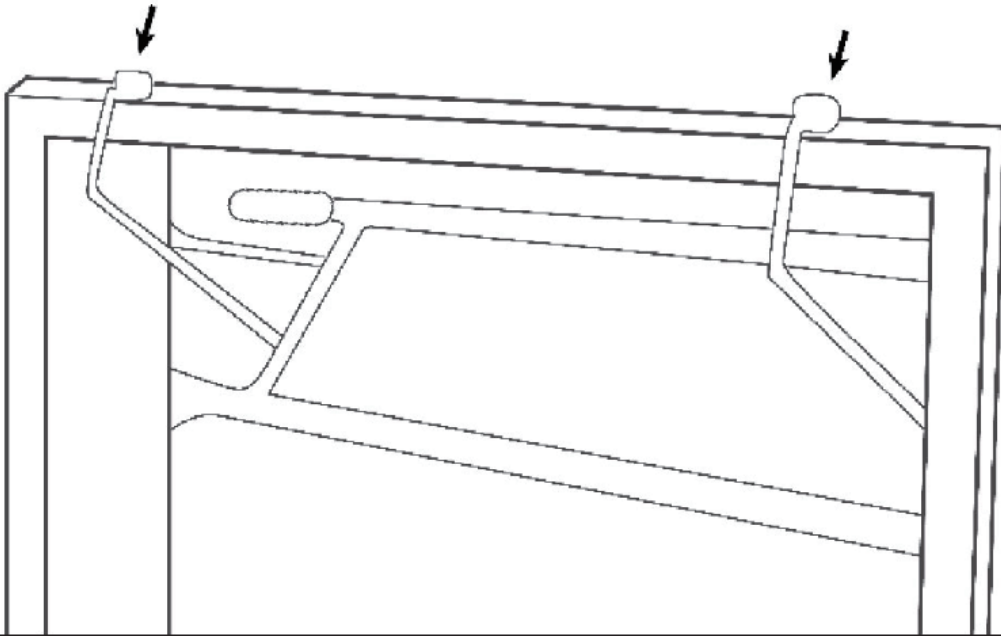

STEP 4

