

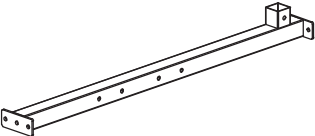

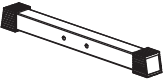







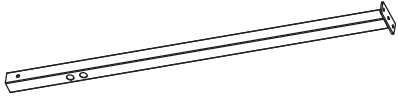
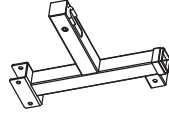
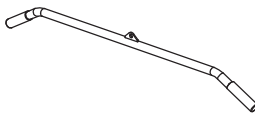

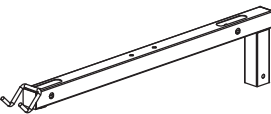
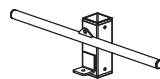



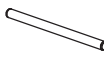





IMPORTANT, RETAIN FOR FUTURE REFERENCE: READ CAREFULLY

ASSEMBLY & INSTRUCTION MANUAL

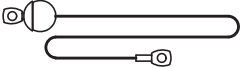
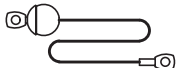
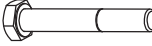
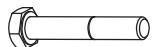
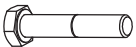
1.PART LIST

<p>A. Base tube 1pc</p> 	<p>B. Cross beam 2pcs</p> 	<p>C. Rear upright 1pc</p> 
<p>D. Bottom upright 1pc</p> 	<p>E. Top upright 1pc</p> 	<p>F. Seat support 1pc</p> 
<p>G. Lat bar 1pc</p> 	<p>H. Seat adjustable board 1pc</p> 	<p>I. Top frame 1pc</p> 
<p>J. Weight bar 1pc</p> 	<p>K. Connecting part 1pc</p> 	<p>L. Row handle 1pc</p> 
<p>M. Seat 1pc</p> 	<p>N. Foam tube 1pc</p> 	<p>O Rubber ring</p> 
<p>P. Hooks 3pcs</p> 	<p>Q. Bumper 1pc</p> 	<p>R. Cover 4pcs</p> 
<p>S. Pulley bushing 6pcs</p> 	<p>T. Knob 1pc</p> 	<p>U. Foam 2pcs</p> 
<p>V. Pulley 3pcs</p> 	<p>W. CLIP 2pcs</p> 	<p>X. UPPER CABLE (2. 33M) 1pc</p> 
<p>Y. LOWER CABLE (1. 65M) 1pc</p> 		<p>1. BOLT M10*70 7pcs</p> 
<p>2. Bolt (M10*65mm) 8pcs</p> 	<p>3. Bolt (M10*60mm) 3pcs</p> 	<p>4. Bolt (M8*20mm) 2pcs</p> 
<p>5. Washer (M8) 2pcs</p> 	<p>6. Washer (M10) 36pcs</p> 	<p>7. Nut (M10) 18pcs</p> 

2.ASSEMBLY STEP



STEP 1

Item	Description	Qty
2	 BOLT M10*65 WASHERS NUT	4

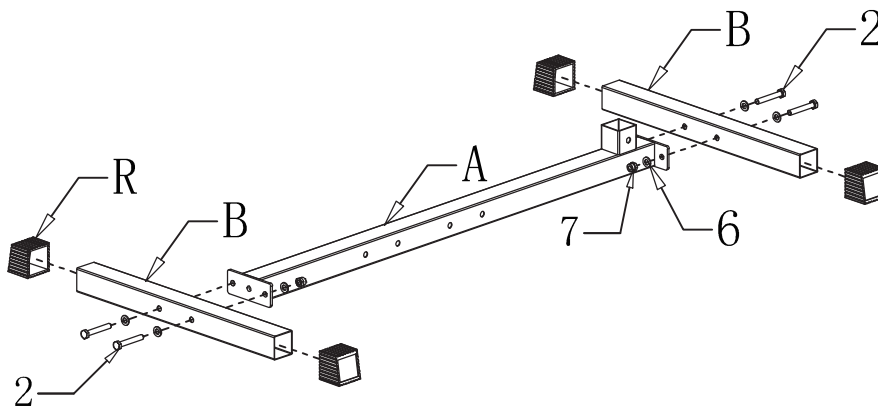
1. PUSH COVERS (R) ONTO THE CROSS BEAMS (B).
2. ATTACH CROSS BEAMS (B) TO THE BASE TUBE (A) USING BOLTS (M10*65) WASHERS AND LOCK NUTS (4SETS).



STEP 2

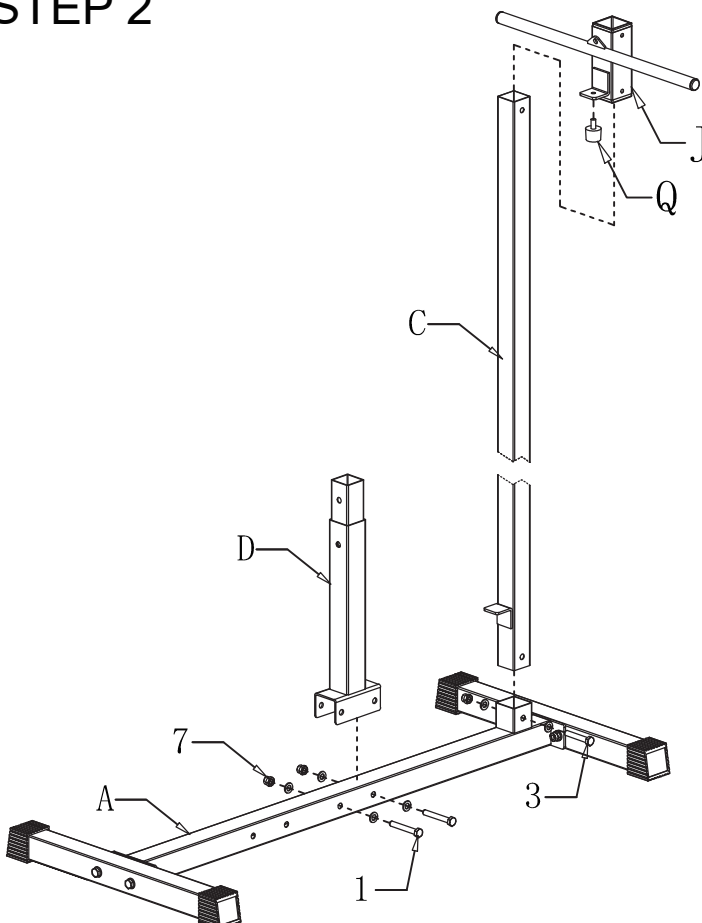

Item	Description	Qty
1	 BOLT M10*70 WASHERS NUT	2
3	 BOLT M10*60 WASHERS NUT	1

1. ATTACH REAR UPRIGHTS (C) TO THE BASE TUBE (A) USING BOLTS (M10*60) WASHERS AND LOCK NUT (1SET).
2. ATTACH BOTTOM UPRIGHT (D) TO THE BASE TUBE (A) USING BOLTS (M10*70) WASHERS AND LOCK NUTS (2SETS).
3. PUSH THE WEIGHT BAR (J) ONTO THE REAR UPRIGHT (C) USING BUMPER (Q).

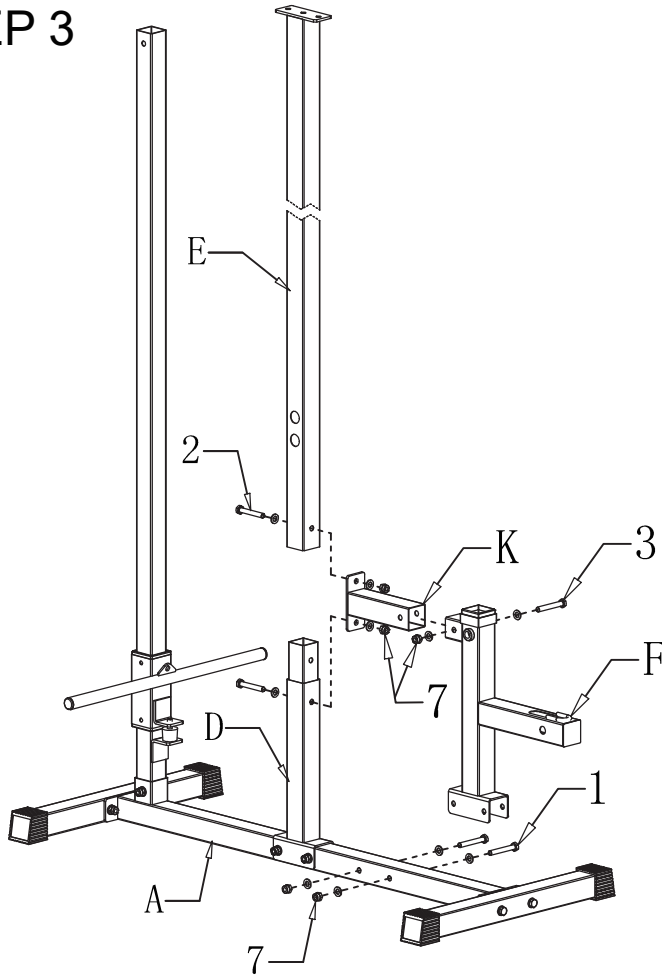

STEP 3



Item	Description	Qty
1	 BOLT M10*70 WASHERS NUT	2
2	 BOLT M10*65 WASHERS NUT	2
3	 BOLT M10*60 WASHERS NUT	1

1. ATTACH TOP UPRIGHT (E) TO BOTTOM UPRIGHT (D) AND CONNECTING PART (K) USING BOLTS (M10*65) WASHERS AND LOCK NUTS (2SETS).
2. ATTACH SEAT SUPPORT (F) TO THE BASE TUBE (A) USING BOLTS (M10*70) WASHERS AND LOCK NUTS (2SETS). THEN ATTACH SEAT SUPPORT (F) TO CONNECTING PART (K) USING BOLTS (M10*60) WASHERS AND LOCK NUT (1SET).

STEP 4

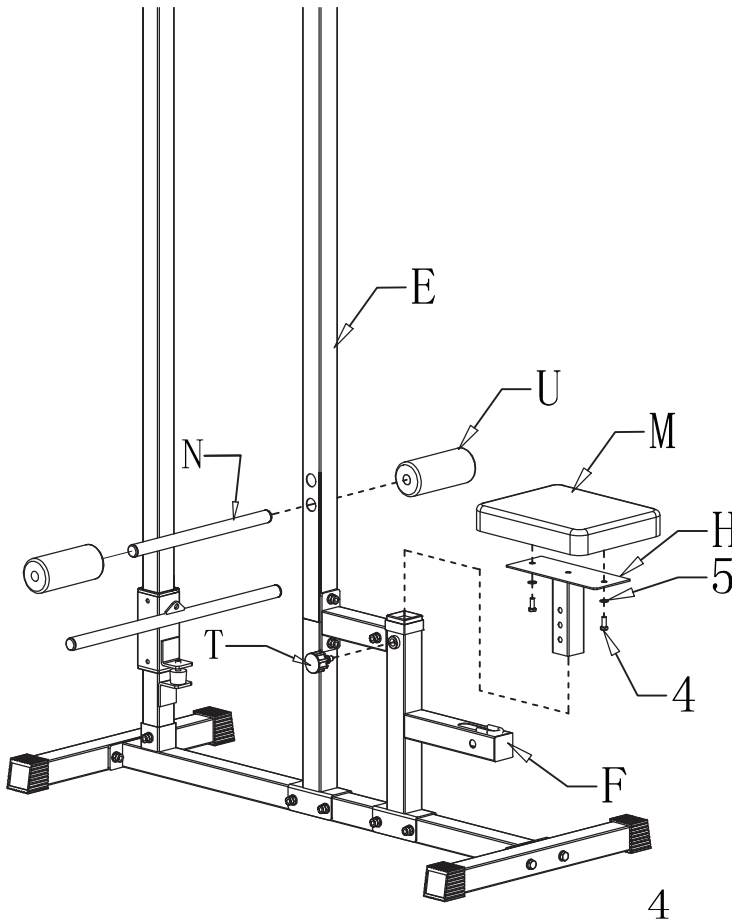



Item	Description	Qty
4	 BOLT M8*20 WASHERS	2

1. ATTACH SEAT ADJUSTABLE BOARD (H) TO THE SEAT SUPPORT (F) USING KNOB (T).
2. ATTACH SEAT (M) TO THE SEAT ADJUSTABLE BOARD (H) USING BOLTS (M8*20) WASHERS (2SETS).
3. PUSH FOAM TUBE (N) INTO THE HOLE OF TOP UPRIGHT (E) AND THEN PUSH TWO FOAMS (U) ONTO FOAM TUBE (N).

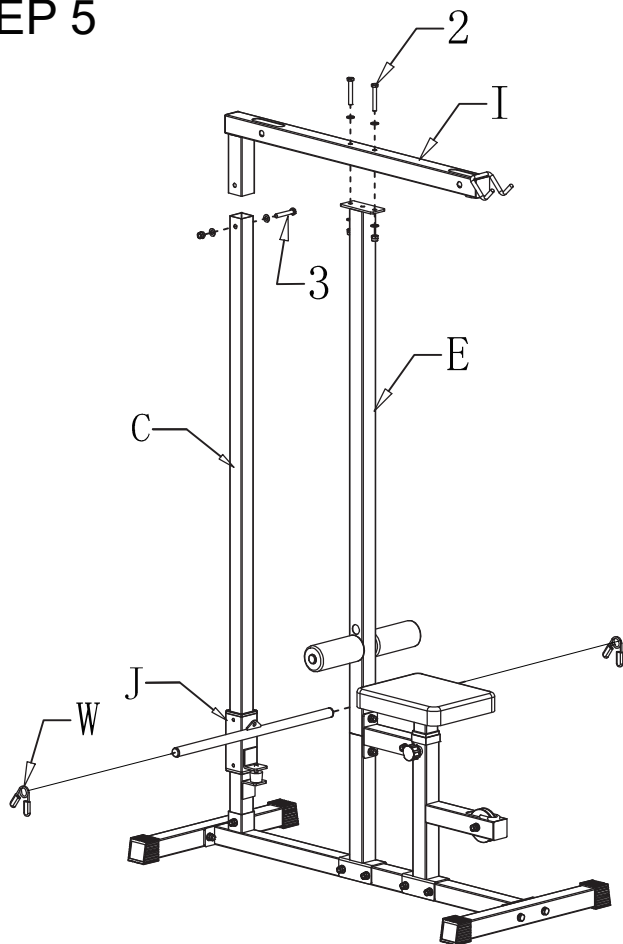
STEP 5



Item	Description	Qty
2	 BOLT M10*65 WASHERS NUT	2
3	 BOLT M10*60 WASHERS NUT	1

1. ATTACH TOP FRAME (I) TO TOP UPRIGHT (E) AND REAR UPRIGHT (C) USING BOLTS (M10*65), BOLTS (M10*60) WASHERS AND LOCK NUTS.
2. INTO THE TUBE OF WEIGHT BAR (J) USING CLIP (W) TO LOCK THEM.

STEP 6

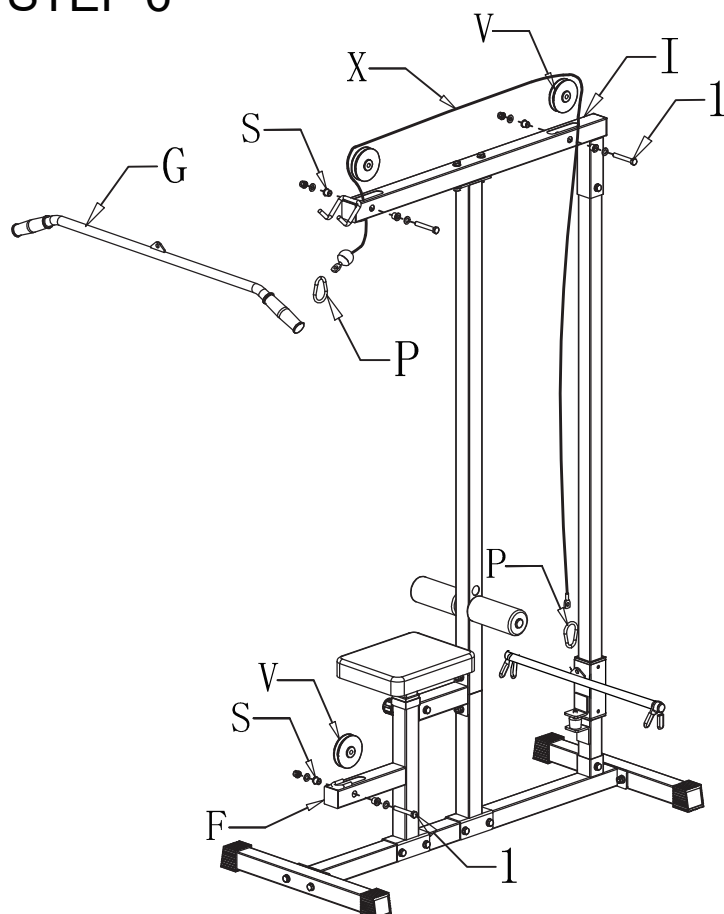

Item	Description	Qty
1	 BOLT M10*70 WASHERS NUT	3

1. ATTACH PULLEY (V) TO THE TOP FRAME (I) AND SEAT SUPPORT (F) USING BOLT M10*70 WASHERS NUT (3SETS) AND PULLEY BUSHING (S).
2. ATTACH THE UPPER CABLE (X) TO THE WEIGHT BAR (J) THROUGH TOP TWO PULLEYS AS SHOWN.

CHECK THE UNIT ON A LEVEL SURFACE BEFORE TIGHTENING ALL BOLTS AND NUTS.

MAKE SURE THE PULLEYS ROTATE FREELY WITHOUT ANY RESISTANCE DUE TO THE OVER TIGHTNESS.

STEP 7

1. ATTACH THE LOWER CABLE (Y) TO THE UPPER CABLE (X) THROUGH PULLEY OF SEAT SUPPORT (F) AS SHOWN.

2 Rubber ring (O)

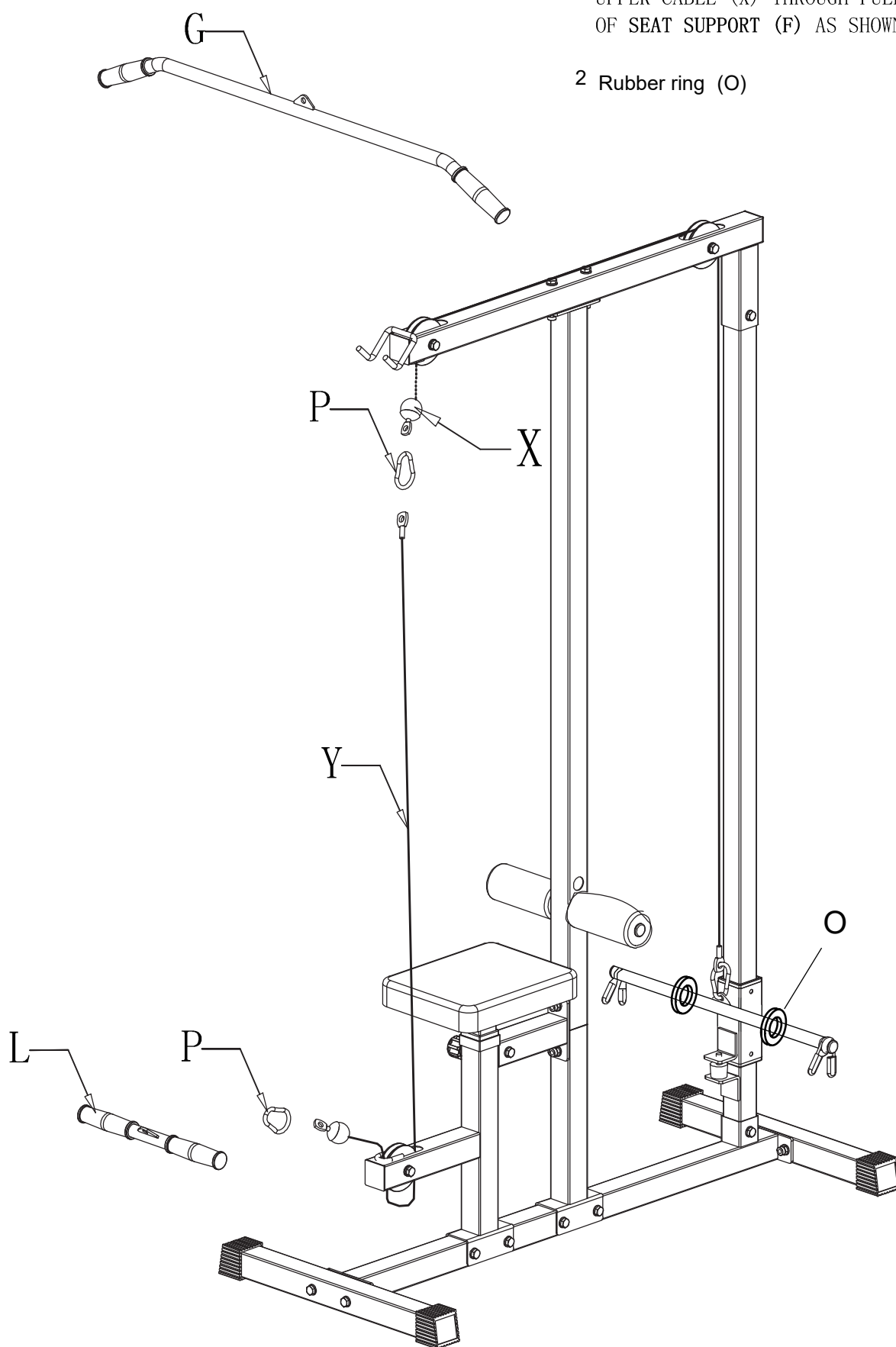

US



001-877-644-9366
customerservice@aosom.com

CA



001-855-537-6088
customerservice@aosom.ca

UK



0044-800-240-4004
enquiries@mhstar.co.uk

DE



0049-(0)40-88307530
service@aosom.de

FR



0033-1-84166106
contact@aosom.fr

ES



0034-931294512
atencioncliente@aosom.es

IT



0039-0249471447
clienti@aosom.it