

Soozier

INamb006V01_US

A91-221

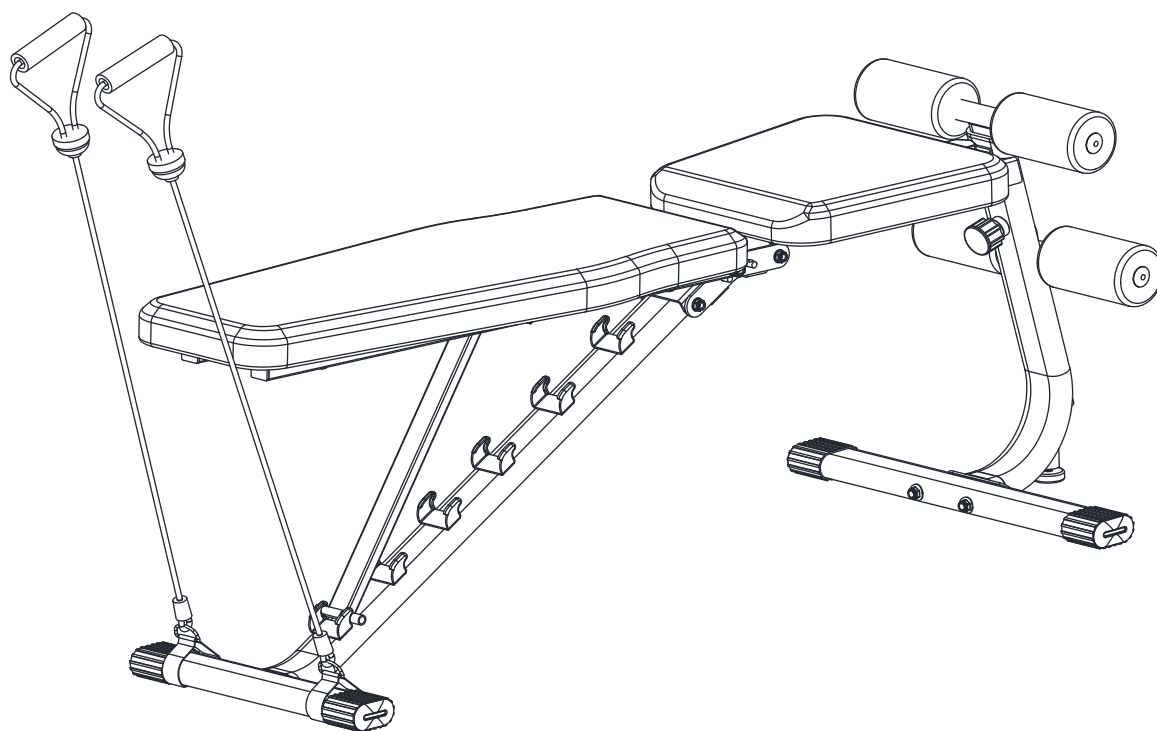

*The maximum user weight is 150 Kg.

IMPORTANT, RETAIN FOR FUTURE REFERENCE: READ CAREFULLY

USING INSTRUCTION



IMPORTANT MESSAGE
WARNING - PLEASE READ

ADULT ASSEMBLY REQUIRED
CHOKING HAZARD Small Parts.
NOT for children under 3 years of age.

WARNING:

While every attempt is made to ensure the highest degree of protection in all equipment, we cannot guarantee freedom from injury. The user assumes all risks of injury due to use. All merchandise is sold on this condition, which no representative of the company can waive or change.

SAFETY INFORMATION

IMPORTANT – Please read fully before assembly or use.

This exercise equipment is built for optimum safety. However, certain precautions apply whenever you operate a piece of exercise equipment. Be sure to read the entire manual before you assemble, operate, or use this equipment, note the following safety precautions.

Warning for assembly

- Ensure you have all the parts and tools listed.
- Remove all fittings from the plastic bags and separate them into their groups.
- Keep children and animals away from the work areas, small parts can cause a choking hazard if swallowed.
- Ensure you have enough space to layout the parts before starting.

The assembly of this equipment is best carried out by 2 persons.

- Assemble the item as close to its final position (in the same room) as possible.
- The free-standing equipment shall be installed on a stable and level base.
- Dispose of all packaging carefully and responsibly.

Warning for using

- This exercise equipment is made for training in private environment. Only use the equipment for its intended use.
- **DO NOT** make any changes to the equipment which can affect the security of the product.
- **Warning! Pregnant or physically injured persons should never use the weight station without prior consultation with a doctor you trust.**
- Be aware of your body's signals. Incorrect or excessive exercise can damage your health.
- **STOP** exercising if you experience any pain, tightness in your chest, irregular heartbeat, extreme shortness of breath, lightheadedness, dizziness, or nausea. If you do experience any of these conditions you should **CONSULT YOUR DOCTOR IMMEDIATELY** before continuing with your exercise program.
- Always adapt your training style to your personal fitness level and health.
- Before every training session, ensure you check the equipment for operation and safety.
- Before using, ensure the item is installed correctly and that all safety devices are functional! Damages or alterations to the product resulting from modification, will invalidate your warranty. For problems resulting from the modification or other restrictions, the seller is not responsible.

- Any damage must be reported to the seller immediately after delivery, and before use or installation. Later complaints will not be considered.
- Use only suitable tools for assembly.
- The installation must ONLY be carried out by adults. Children should not be present in the immediate environment where the assembly is taking place.
- Make sure all connections are securely mounted before releasing the product for use.
- Check all connections at regular intervals for damage, loose elements and other factors that can lead to a loss of sufficient security.
- Do not leave children unattended on the weight bench! It is not a toy! Instruct them not to play with or climb on the appliance.
- In case of a fault during day-to-day use, or during maintenance, lock the equipment to prevent any risk of injury.
- Children or persons with limited physical or mental abilities, or those not familiar with this device, should not be allowed to use this weight bench!
- Please keep in mind that this manual and the safety can only draw your attention to eventual hazard. Logical conclusions and care should always be practiced when handling this device.
- Before using the equipment to exercise, always warm up with stretching exercises.
- Before using the equipment, check the nuts and bolts are securely tightened.
- Use the equipment on a solid, flat surface with a protective cover for your floor or carpet.
- The safety level of the equipment can only be maintained if it is regularly examined for damage and/or wear and tear. If you find any defective components whilst assembling or checking the equipment, or if you hear any unusual sounds, from the equipment during use, STOP! Do not use the equipment until the problem has been rectified.
- Wear suitable clothing whilst using the equipment. Avoid wearing loose clothing which may get caught in the equipment or that may restrict or prevent movement.
- Before starting any exercise or conditioning program you should consult with your personal physician to see if you require a complete physical exam. This is especially important if you are over the age of 35, have never exercised before, are pregnant, or suffer from any illness.

CLEANING AND MAINTENANCE

1. Regularly examine the equipment to detect any damage to wear which may have occurred.



The safety level of the equipment can be maintained only if it is examined regularly for damage and wear and tear on ropes, pulleys, and connection points.

2. Lubricate moving parts with light oil periodically to prevent premature wear.

3. Inspect and tighten all parts before using the equipment. Replace defective components immediately and/or keep the equipment out of use until repair. Pay particular attention to components most susceptible to wear.

4. The equipment can be cleaned using a soft, damp cloth. Do not use solvents or abrasive cleaners.

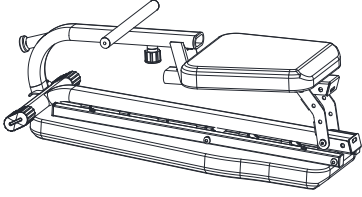
PARTS LIST

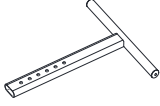
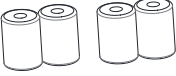
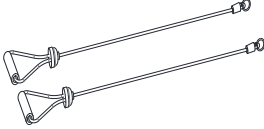
No.	Name	Picture	quantity
1	Main Frame		1
2	Foot tube		1
3	Handrail assembly		1
4	Foam		4
5	Pull rope		2

SCREW PACKAGE LIST

No.	Name	Specification	Unit	quantity
6	Ring pull pin	Ø8*75	Pcs	2
7	Bolt	M8X20	Pcs	1
8	Bolt	M8*75	Pcs	2
9	Washer	φ8.5*φ16*1	Pcs	2
10	Nut	M8	Pcs	2
11	L wrench		Pcs	1
12	Open-end wrench		Pcs	1

01

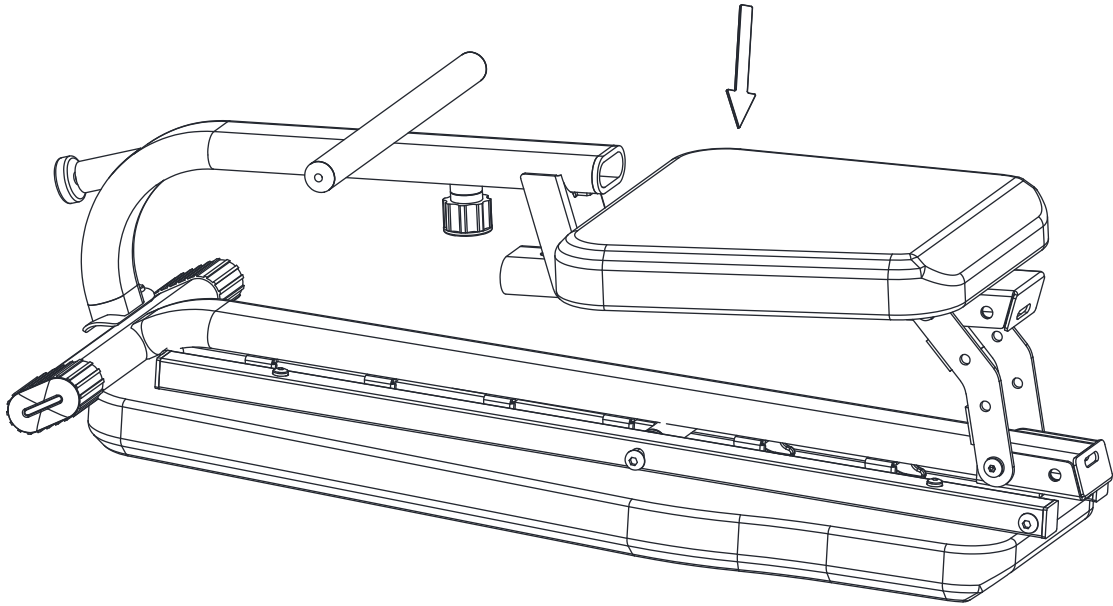

02

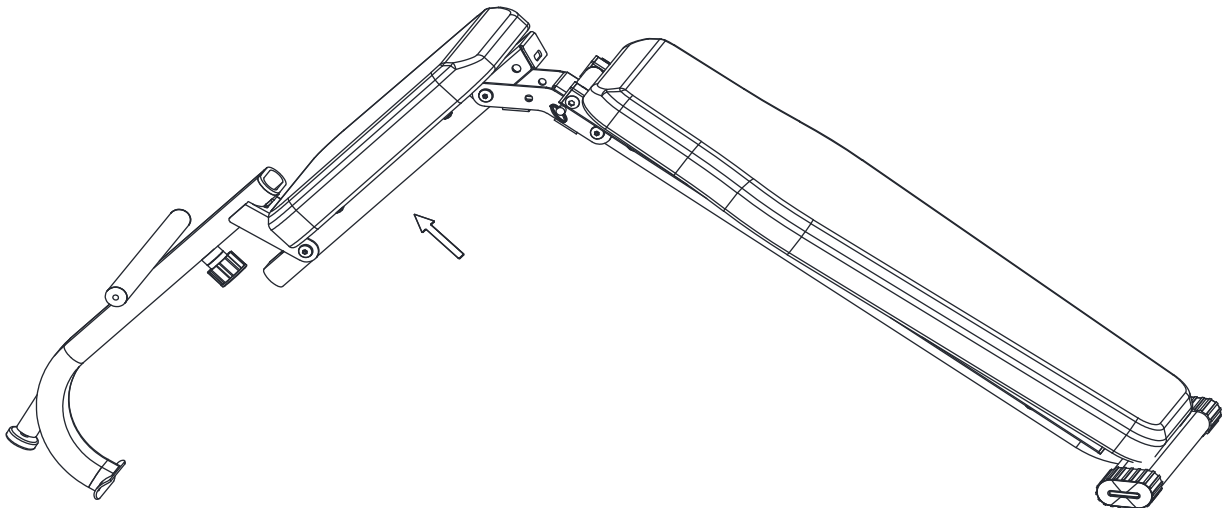

03

⑥ x 2

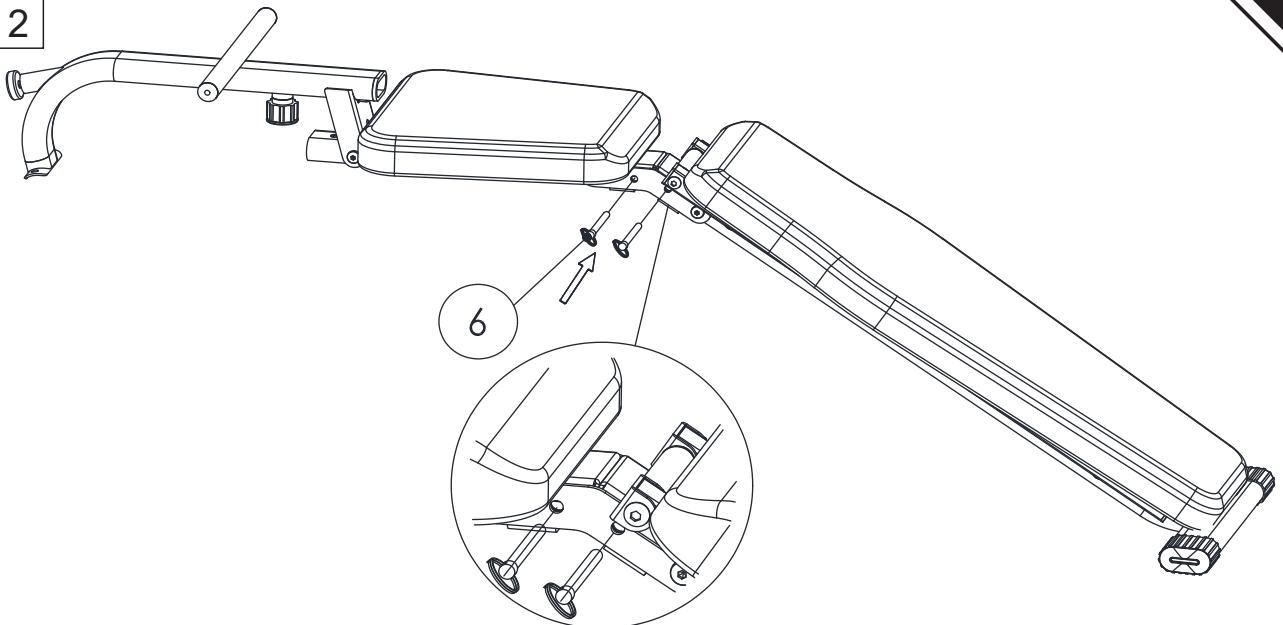

04

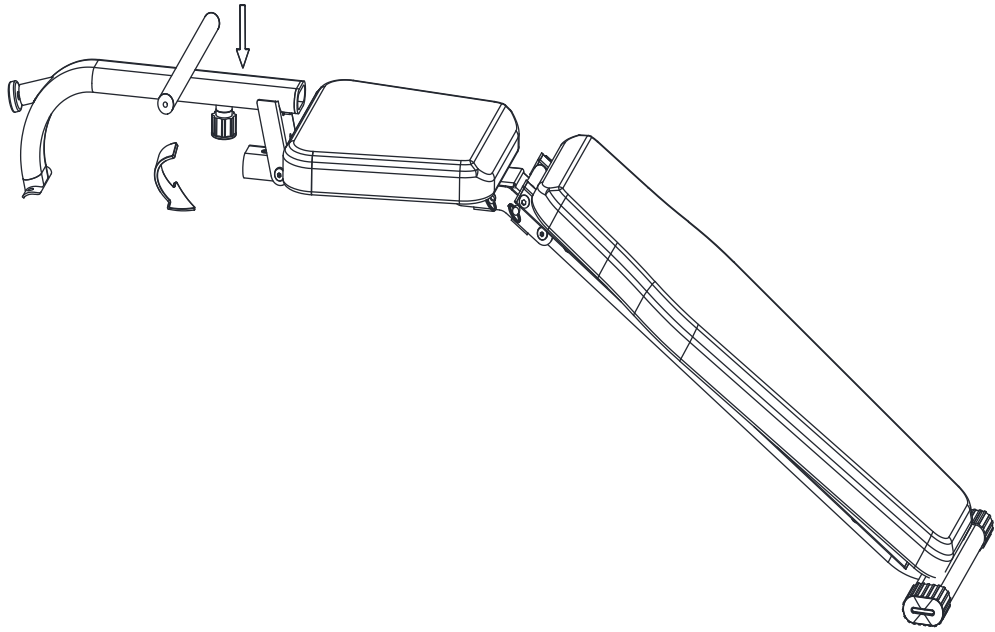

05

7 x 1

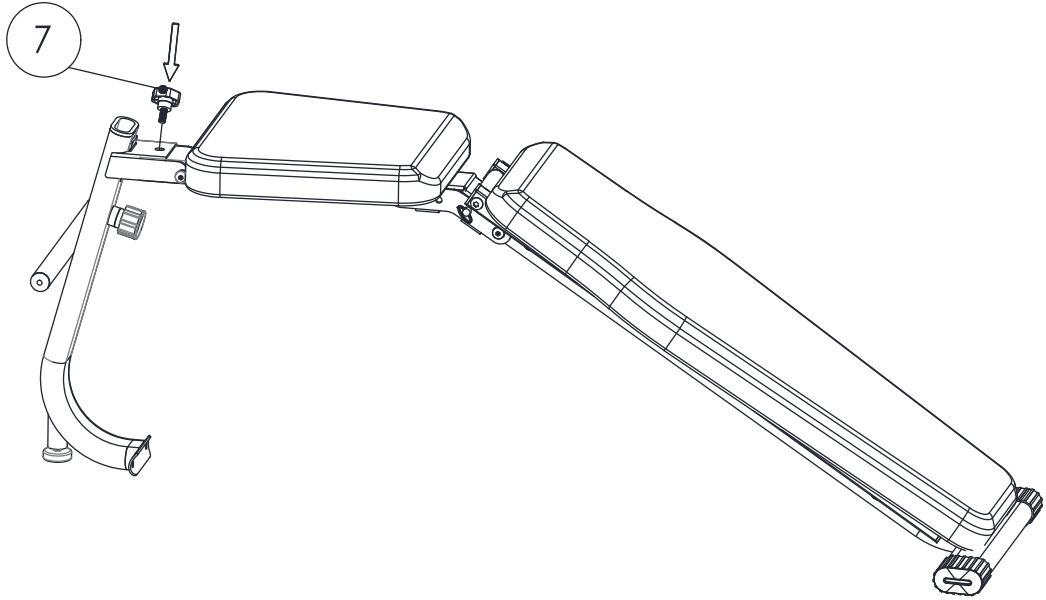

06

8 x 2

9 x 2

10 x 2

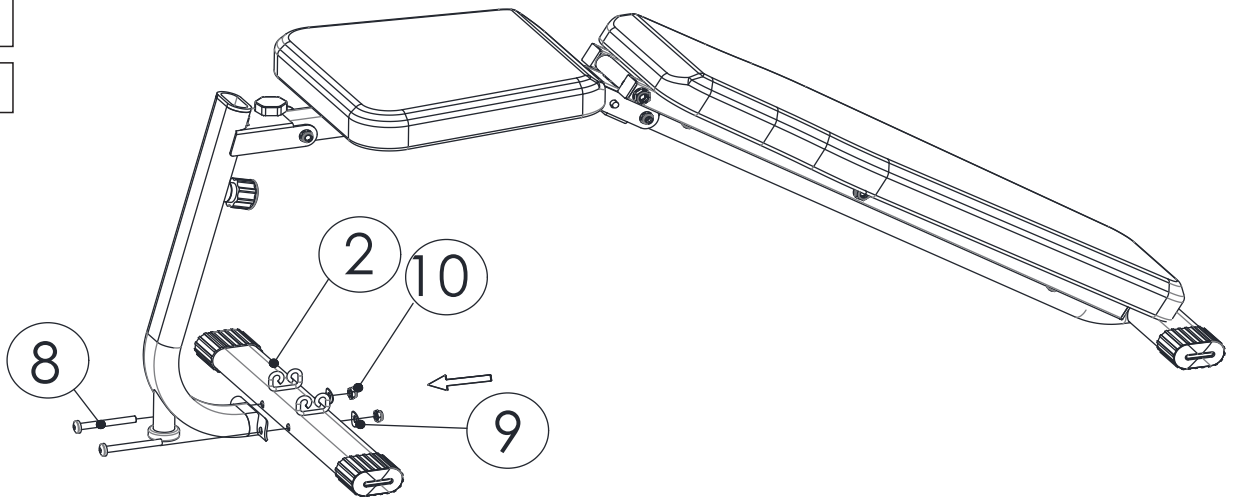

07

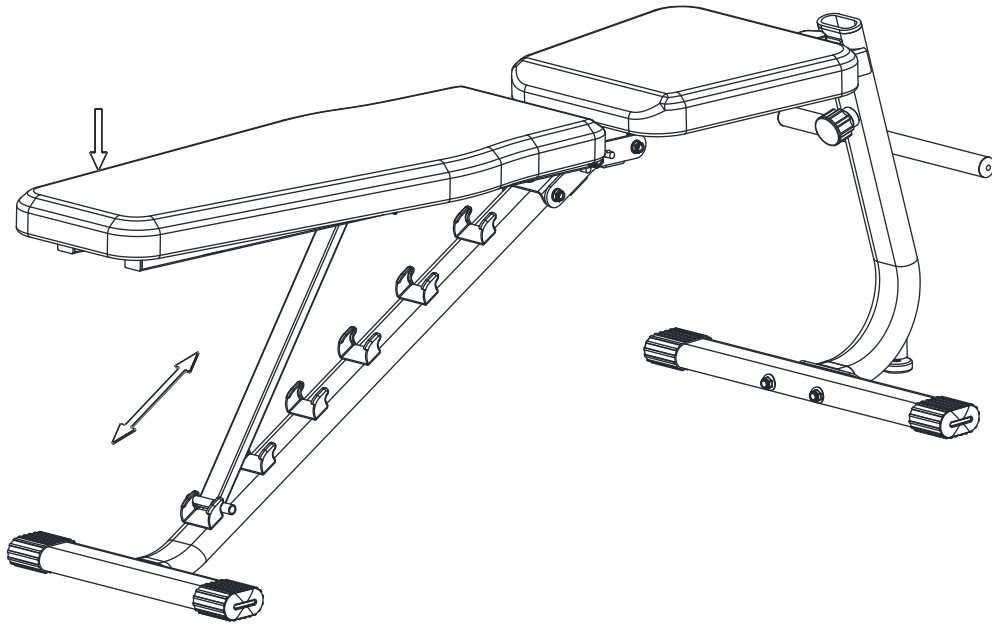

08

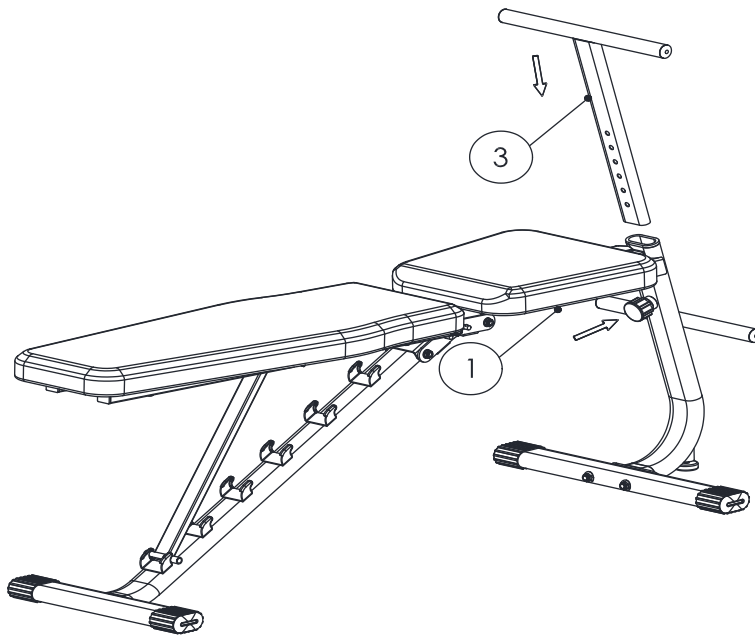

09

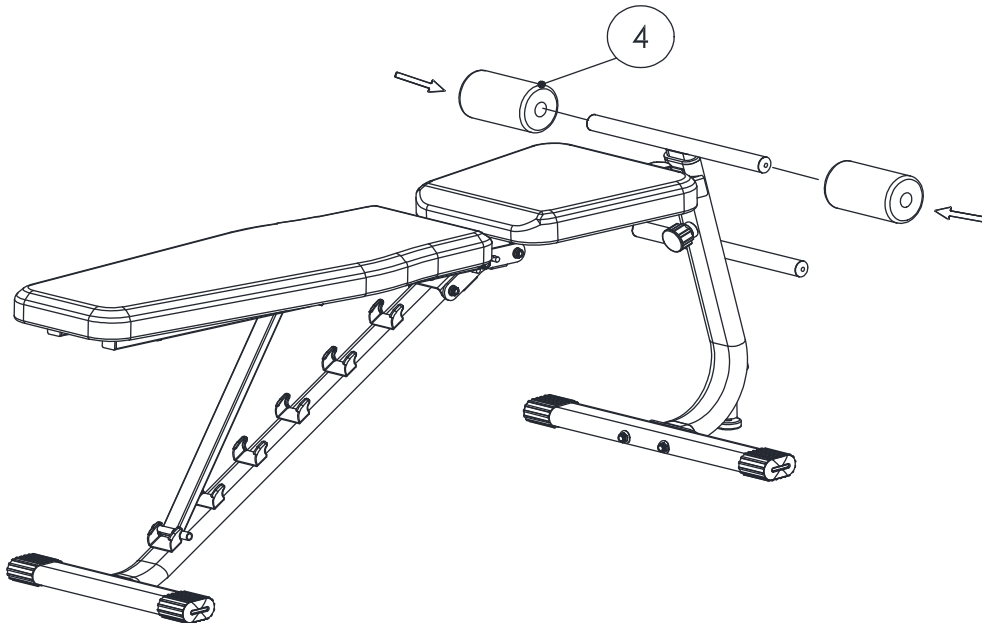

10

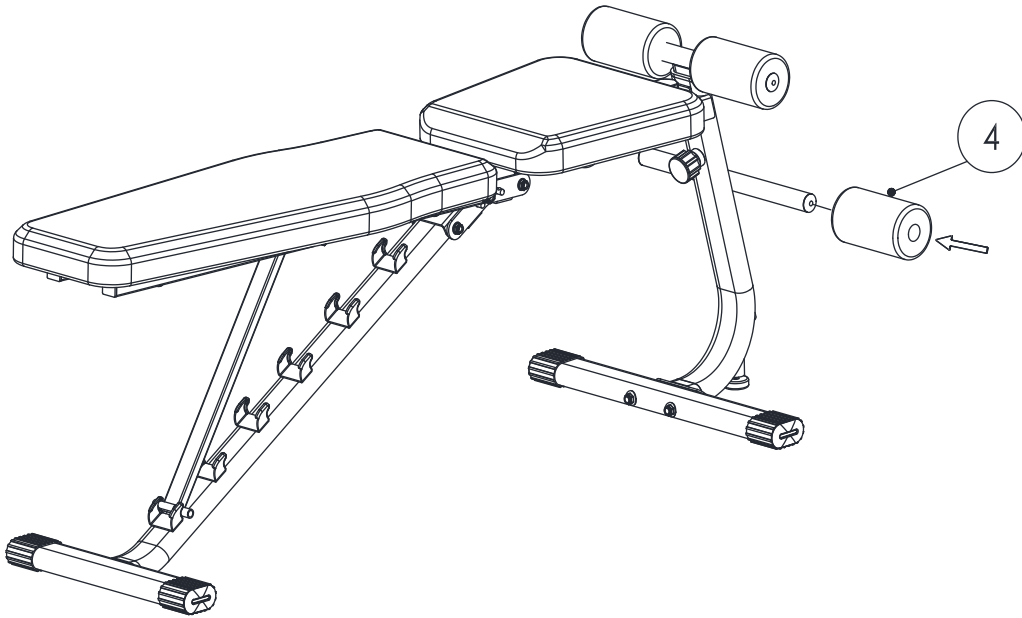

11

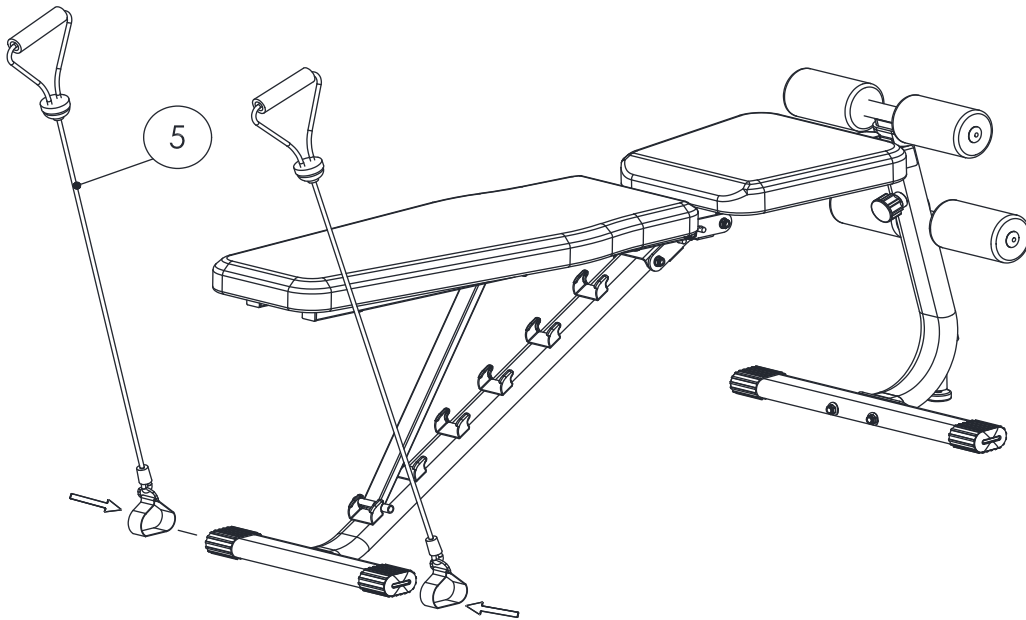

Done

