

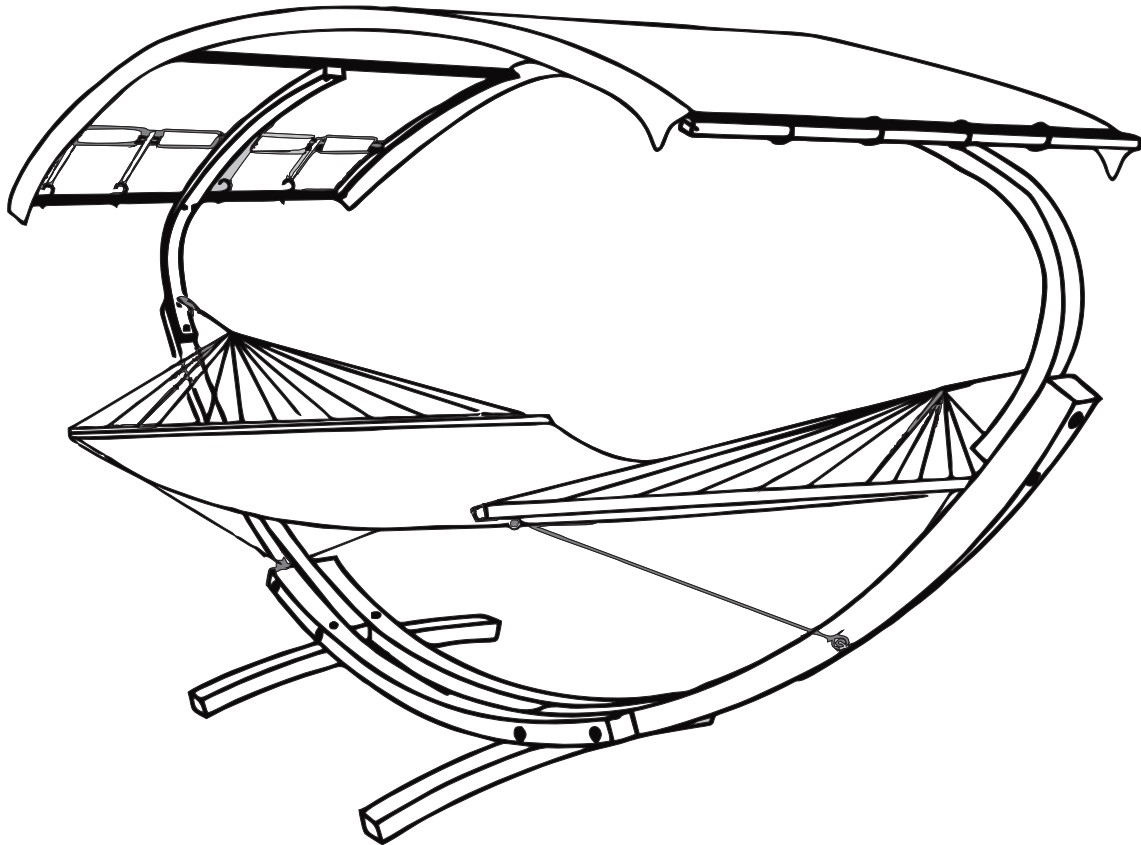























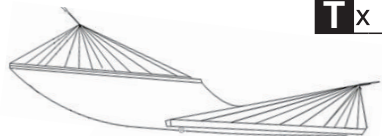

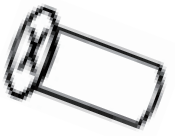





INba023V02_GL

01-0858

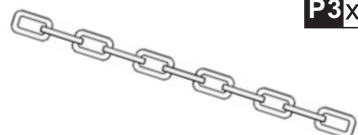

READ AND SAVE THIS INSTRUCTIONS FOR FUTURE USE

ASSEMBLY & INSTRUCTION MANUAL

 A x 2	 J x 4	 R x 4
 B x 2	 K x 4	 S1 x 2
 C x 2	 L x 2	 S2 x 1
 D x 4	 M x 8	 T x 1
 E x 18	 N x 12	 U x 4
 F x 12	 O x 2	 V x 4
 G x 2	 P1 x 8	 W x 2
 H x 4	 P2 x 4	 X x 8
 I x 2	 P3 x 2	 Y x 2
 Q x 4	 Z x 1	

Note : Do not tighten bolts fully until all parts are connected!

Note : Ne serrez pas les boulons à fond tant que toutes les pièces ne sont pas connectées!

Hinweis: Ziehen Sie die Schrauben erst fest an, wenn alle Teile verbunden sind!

Nota: non serrare completamente i bulloni fino a tutte le parti non sono ancora collegate!

Nota: No apriete los tornillos completamente hasta que todas las partes están conectadas!



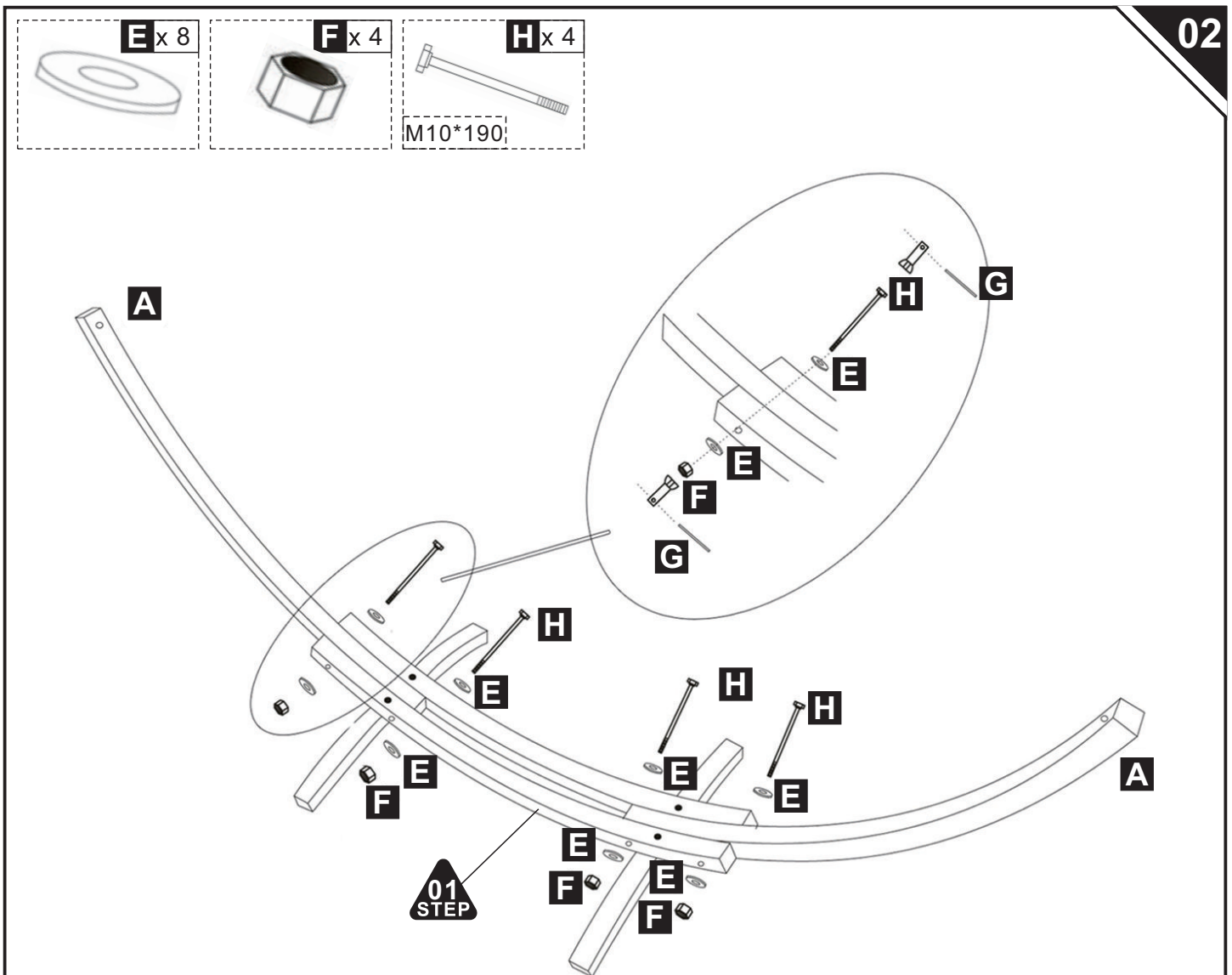
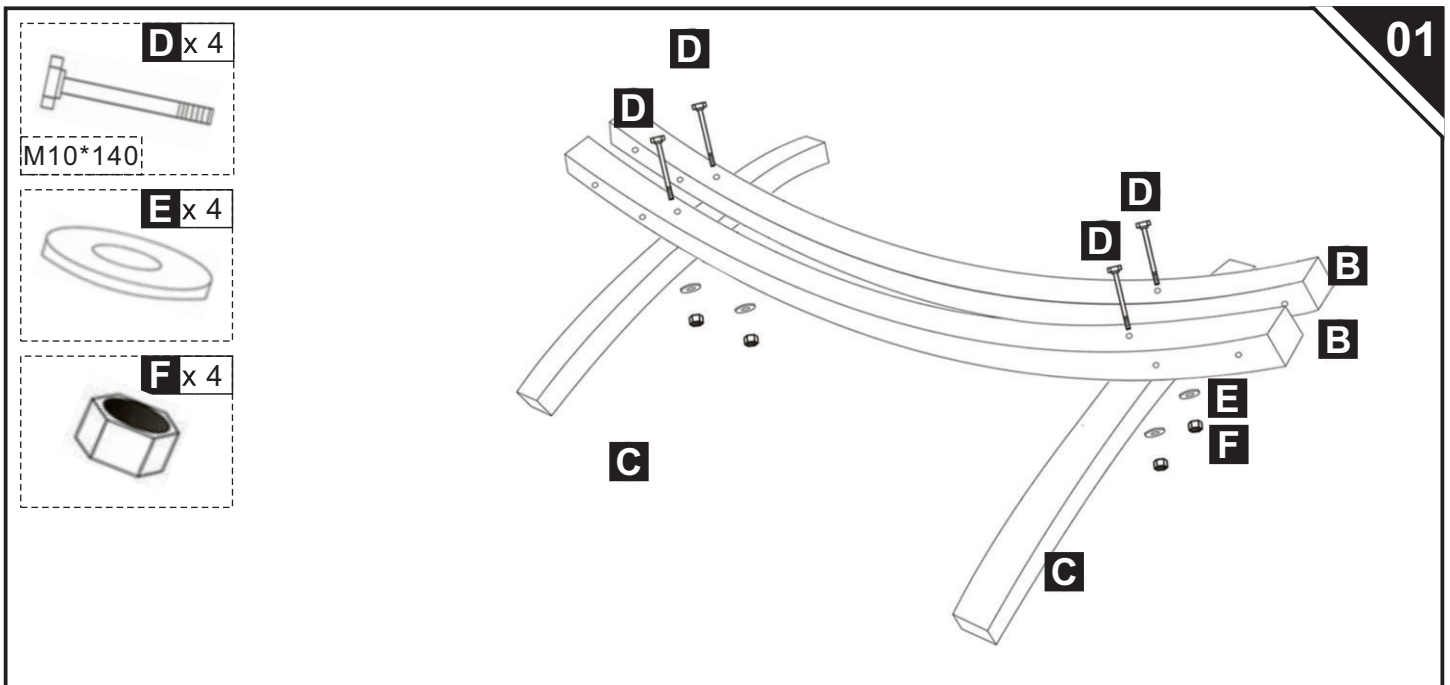

UK_Digrams showing bolts "D" and washers "E" for part "B" + "C". Tighten them well otherwise part "C" will crack if not secured.

DE_Verwenden Sie bitte Schraube D und Unterlegscheibe E, um Teil B und Teil C zusammen zu montieren.

ES_Utilice el perno D y la arandela E para fijar la parte B y la parte C juntas.

FR_Utilisez le boulon D et la rondelle E pour fixer la partie B et la partie C ensemble.

IT_Utilizzare il bullone D e la rondella E per fissare insieme le parti B e C.

- I** x 2
- M10*80
- J** x 4

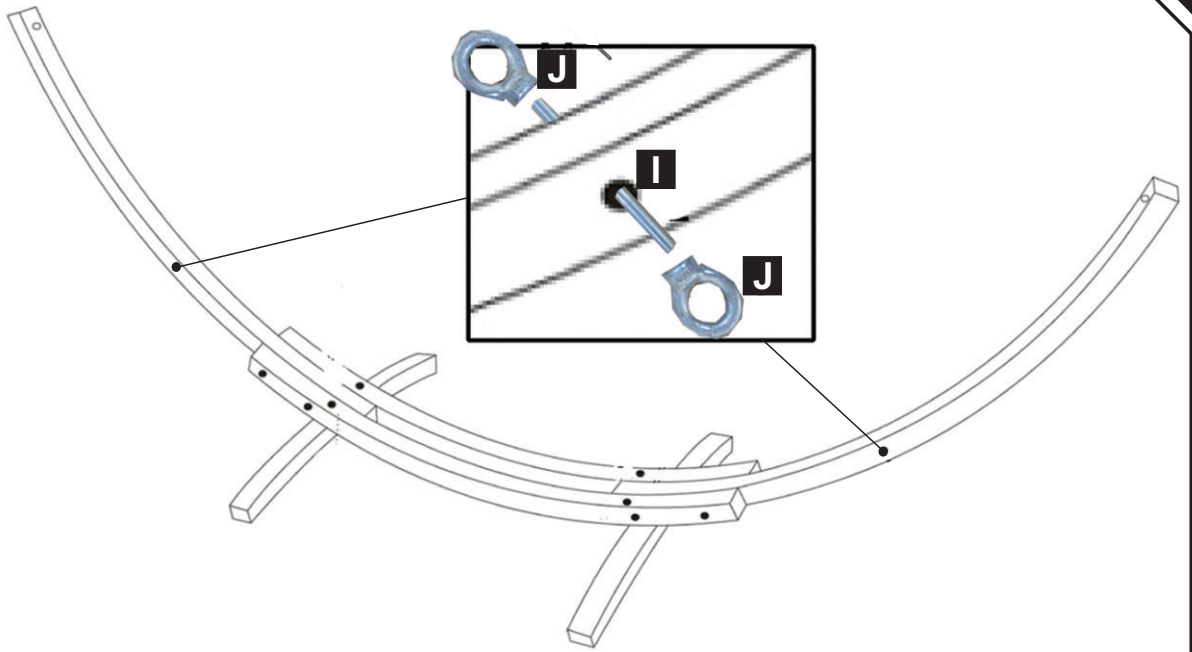

- M** x 4
- M8*45
- N** x 4
- P**1 x 4
- M6*45

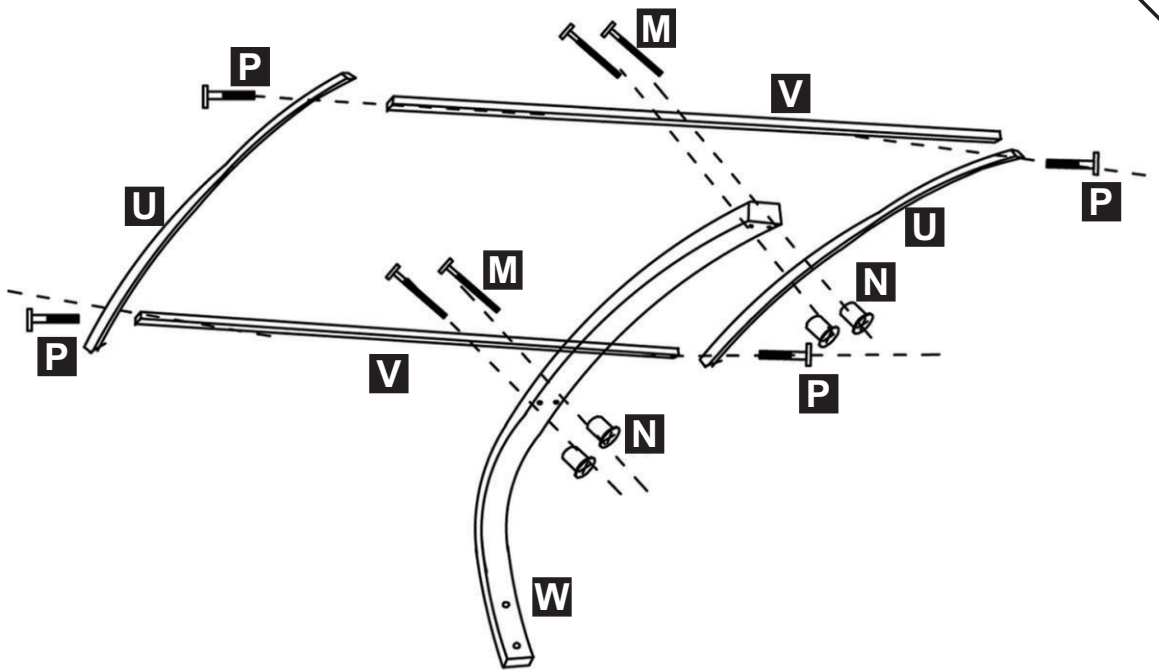

x2



E x 6



F x 4



L x 2



M10*110

O x 2



M10*110

P2 x 4

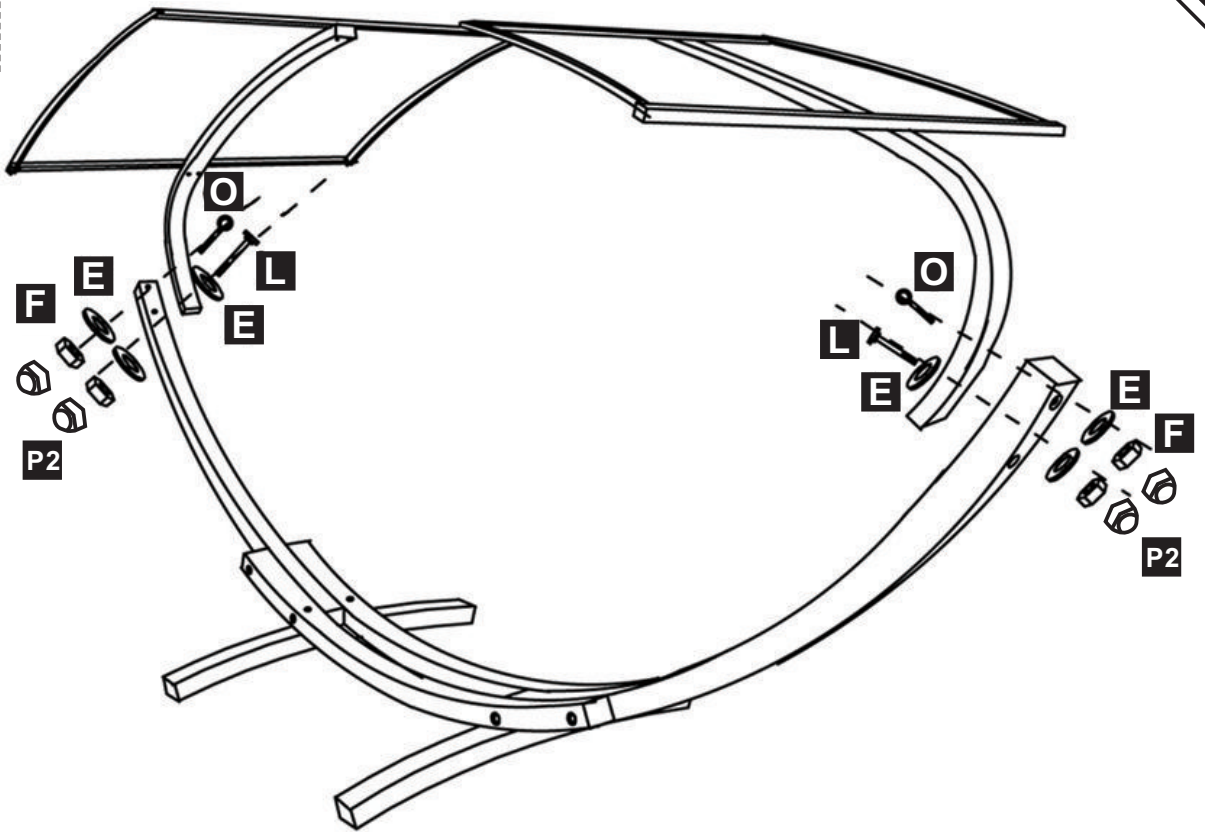

K x 4



N x 4



P3 x 2



Q x 4



R x 4

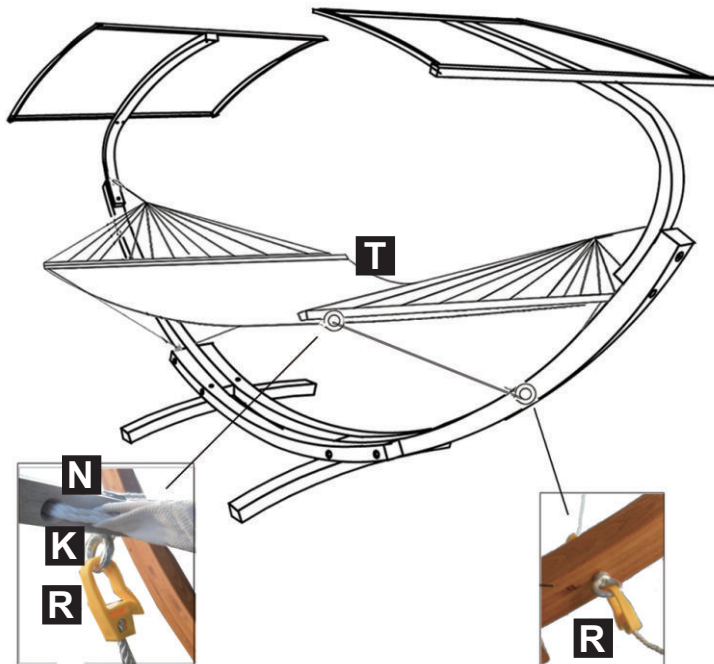
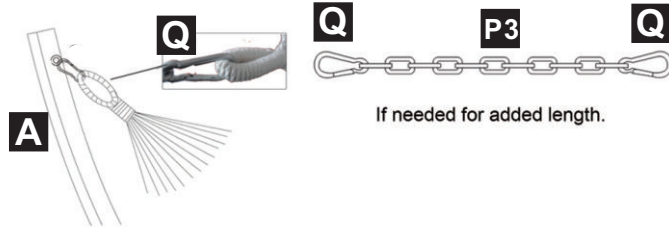

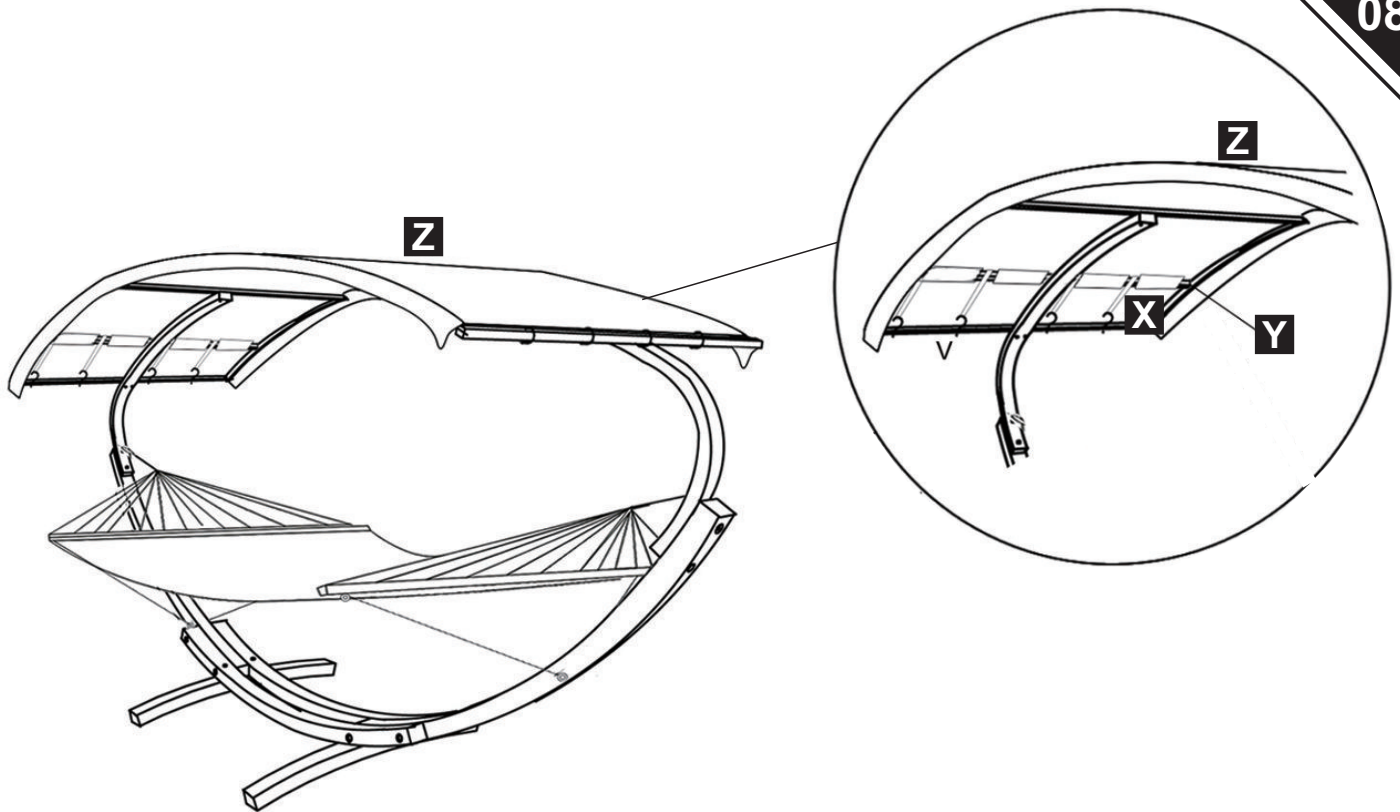

UK_Put Part Y through Part Z, then use Part X fix on Part V.

DE_Bitte fügen Sie Teil Y in Teil Z ein und hängen Sie anschließend Teil X zur Befestigung an Teil V.

ES_Inserte la Parte Y y la Parte Z, luego fije la Parte X en la Parte V.

FR_Mettez la partie Y, insérez la partie Z, puis accrochez la partie X sur la partie V pour la fixation.

IT_Inserire la parte Y nella parte Z, quindi appendere la parte X sulla parte V per essere fissata.

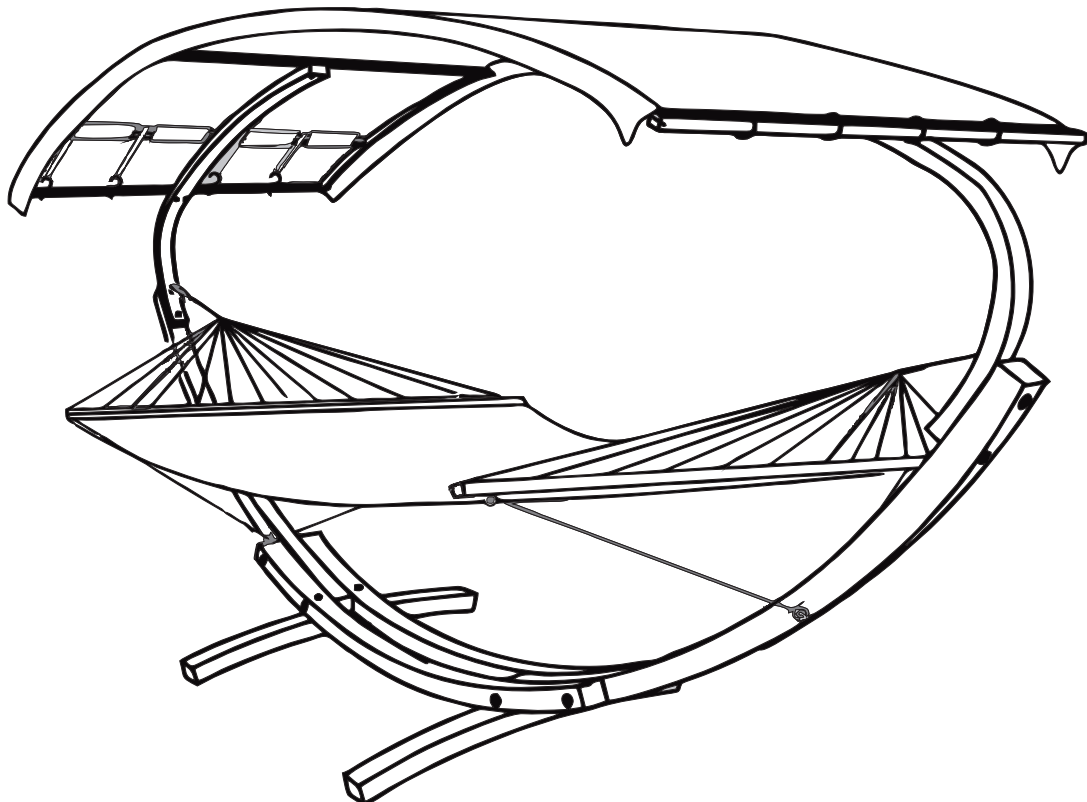

US



001-877-644-9366
customerservice@aosom.com

CA



001-855-537-6088
customerservice@aosom.ca

UK



0044-800-240-4004
enquiries@mhstar.co.uk

DE



0049-(0)40-88307530
service@aosom.de

FR



0033-1-84166106
contact@aosom.fr

ES



0034-931294512
atencioncliente@aosom.es

IT



0039-0249471447
clienti@aosom.it