

Tools Recommended





**EN\_IMPORTANT, RETAIN FOR FUTURE REFERENCE: READ CAREFULLY.**



**FR\_IMPORTANT: A LIRE ATTENTIVEMENT ET À CONSERVER POUR CONSULTATION ULTÉRIEURE.**

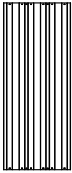
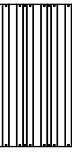
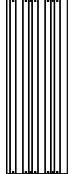

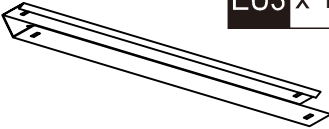

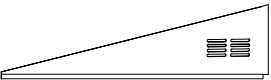
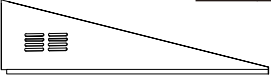
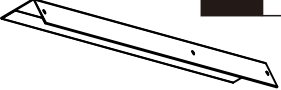
**ES\_IMPORTANTE, LEA Y GUARDE PARA FUTURAS REFERENCIAS.**

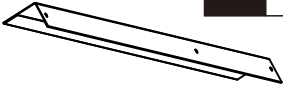
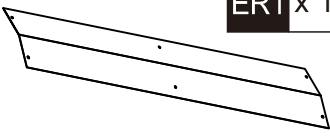
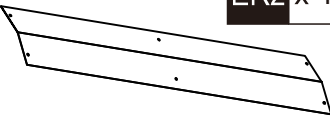
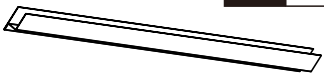
**DE\_WICHTIG! SORGFÄLTIG LESEN UND FÜR SPÄTER NACHSCHLAGEN AUFBEWAHREN.**

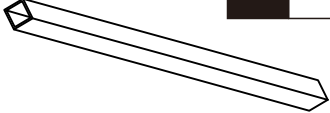



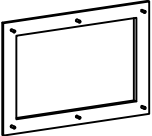
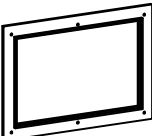
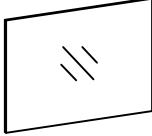
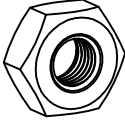



**IT\_IMPORTANTE! CONSERVARE IL PRESENTE MANUALE PER FUTURO RIFERIMENTO E LEGGERLO ATTENTAMENTE.**

<b>BOX 1-2</b>		EP1 x 14
		EP2 x 6
		EP4 x 2
		EU1 x 8
		EU2 x 4
		EU3 x 1
		EA1 x 4
		EGL1 x 2
		EGR1 x 2
		ETL1 x 4

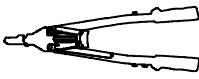
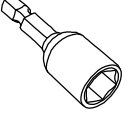
	ETL2 x 2
	ETL3 x 2
	ER1 x 1
	ER2 x 1
	ET1 x 1
	ET2 x 2
	EV1 x 1
	EM x 2

<b>BOX 2-2</b>		EDL x 1
		EDR x 1
		PH1 x 2
		PH2 x 2
		PH3 x 2
		M4 x 12
		
	Hardware Kit	

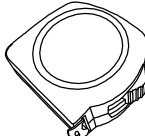
## Required tools:

Tools					
	Gloves	Safety Glasses	Shoes	Riveting Gun	Sleeve
					
	Power drill	Screw driver	Pencil	Tape Measure	Ladder

## Tips:

1. Clear a working area to allow access on 4 sides. A raised work surface will make assembly easier.
2. All parts are identified so when working through the instructions page by page the diagrams show where each part is positioned.
3. Some of the holes have been pre-punched, to allow fixing using self-tapping screws or rivets, where additional holes are required a drill bit is included.
4. Before starting, to avoid any accidental injury, we recommend the use of gloves to protect your hands, safety glasses to protect your eyes and shoes or boots to protect your feet.
5. Please keep children away from your construction site.
6. Most assembly can be completed by one person, assistance may be needed when you reach the erection stage.
7. Please note: Some local government authorities have rules & regulations on shed installation and you may need approval to erect this shed.
8. If you find the accessories are slight deformation, please use tools to recuperate, which will not affect normal use.

## Steps:

1. Unpack all components from the carton and lay outside your work area and check parts against the part list on the next page.
2. Work through assembly instructions Page by Page
3. When completed place shed in position and anchor securely to the ground.
4. Clean up all metal pieces, rivets and screws.

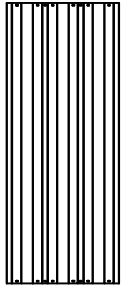

EP1 x14  
L1850

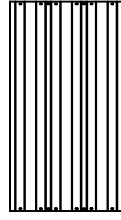

EP2 x6  
L1240

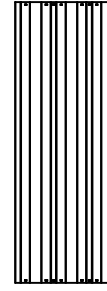

EP4 x2  
L1850

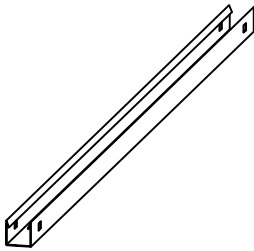

EU1 x8  
L1134

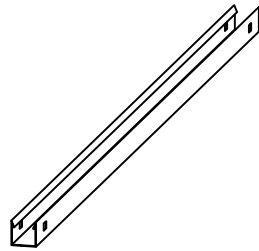

EU2 x4  
L1125

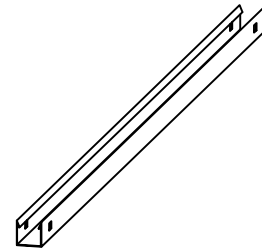

EU3 x1  
L871

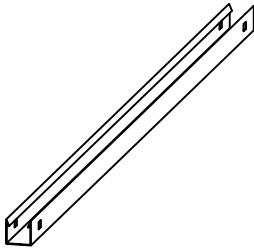

EA1 x4  
L750

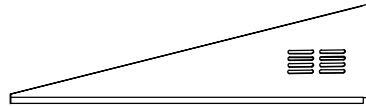

EGL1 x2  
L1083

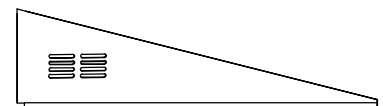

EGR1 x2  
L1083

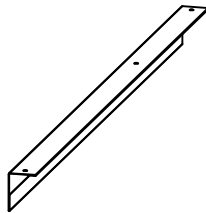

ETL1 x4  
L1235

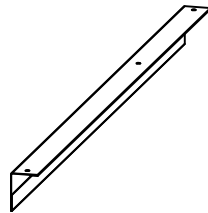

ETL2 x2  
L593

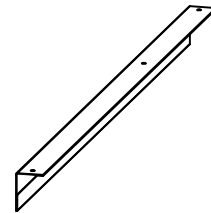

ETL3 x2  
L593

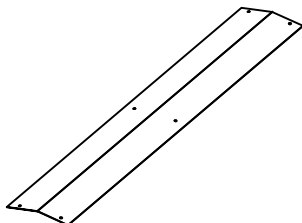

ER1 x1  
L783

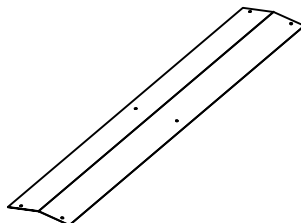

ER2 x1  
L402

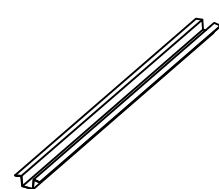

EV1 x1  
L1164

ET1 x1  
L871

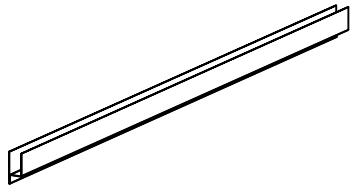

ET2 x2  
L1848

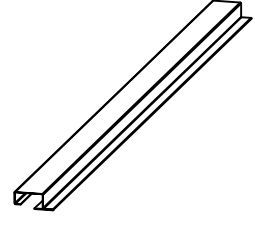

EM x2  
L1848

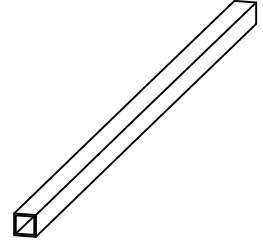

EDR x1  
L1791



EDL x1  
L1791



**ELG** x2

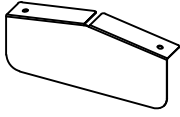

**EG1** x8  
+2(Spare)

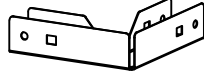

**EJ1** x4  
+2(Spare)

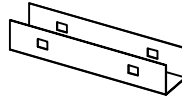

**EH** x2



**L3** x36

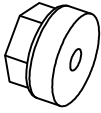

**UV** x1

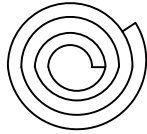

**S3** x146  
+2(Spare)



**S7** x58  
+2(Spare)

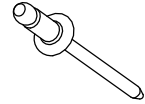

**S16** x6  
+2(Spare)



**EC1** x8

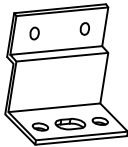

**S11** x8

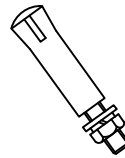

**EV2** x4

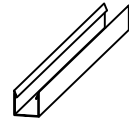

**EV4** x2

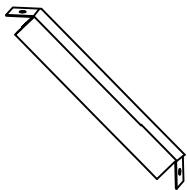

**MSB** x6

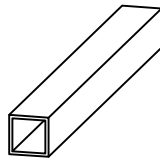

**L1A** x4

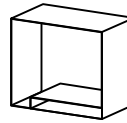

**H2** x1

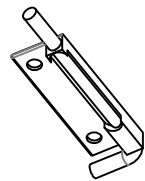

**H3** x1

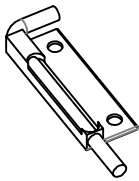

**H1B** x1

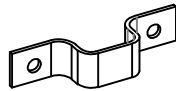

**SH1** x6

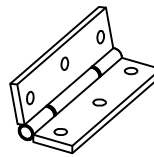

**Drill**

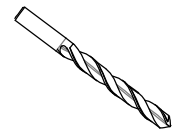

**PH1** x2  
For Window

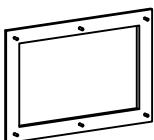

**PH2** x2  
For Window

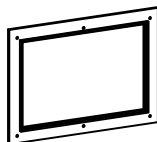

**PH3** x2  
For Window

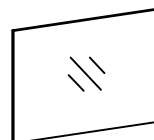

**M4** x12  
For Window

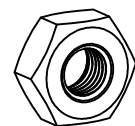

**Lock**





**Gloves**





# PANEL ASSEMBLY LEFT & RIGHT WALLS

	EP1	3		EU2	2	× 2
---	-----	---	---	-----	---	-----

STEP1

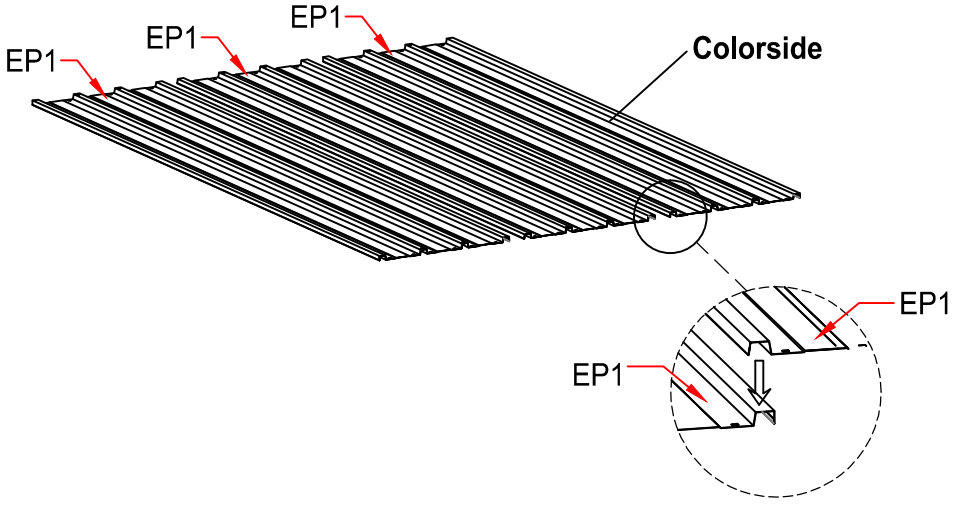

STEP2

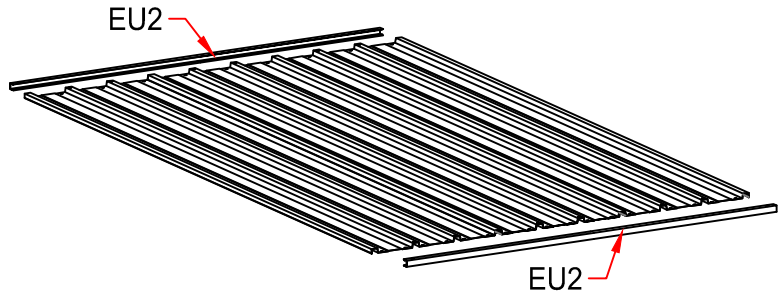



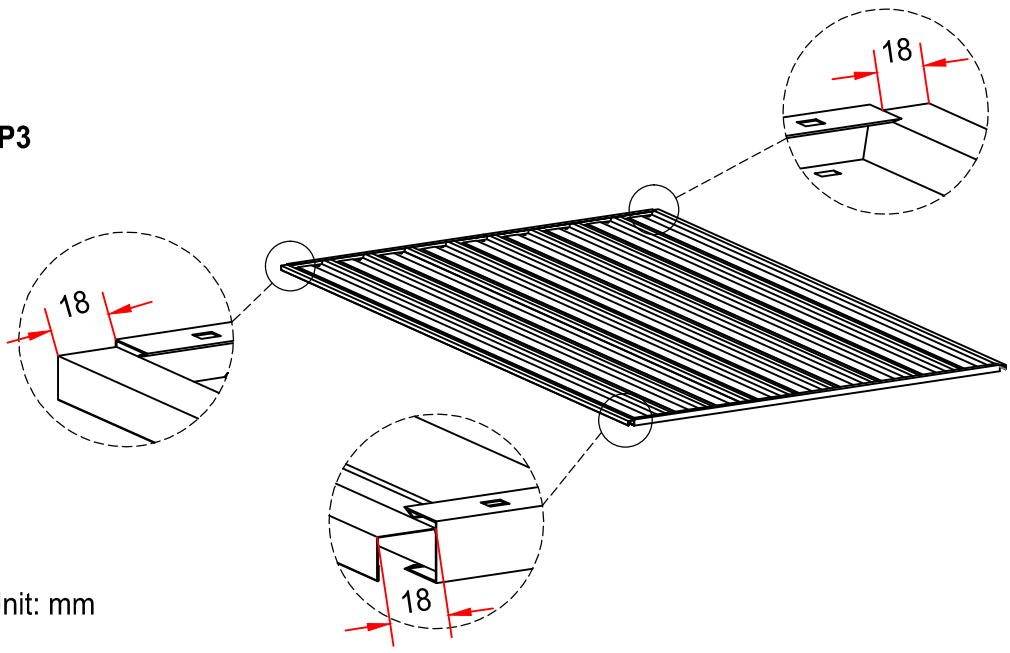



STEP3



Unit: mm



# PANEL ASSEMBLY STEP1-2 FRONT WALLS

	EP1	2		EP4	2		EU1	4		ET2	2
	EM	2		EJ1	2		S3	8			

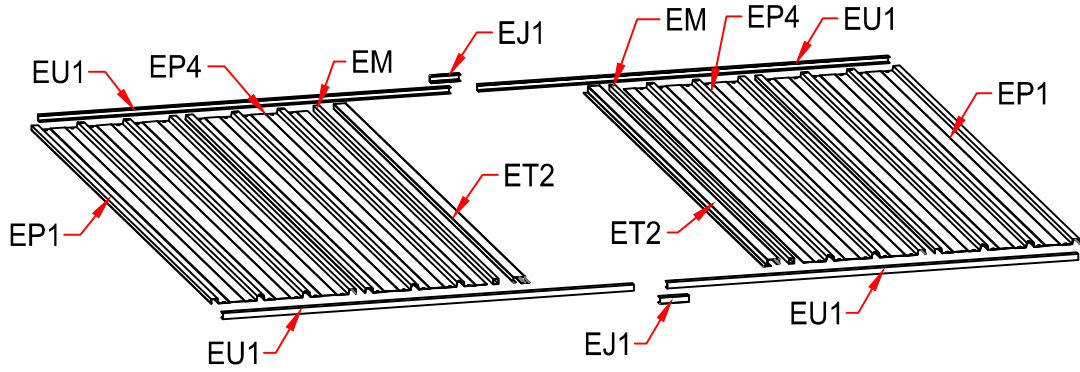

## STEP1

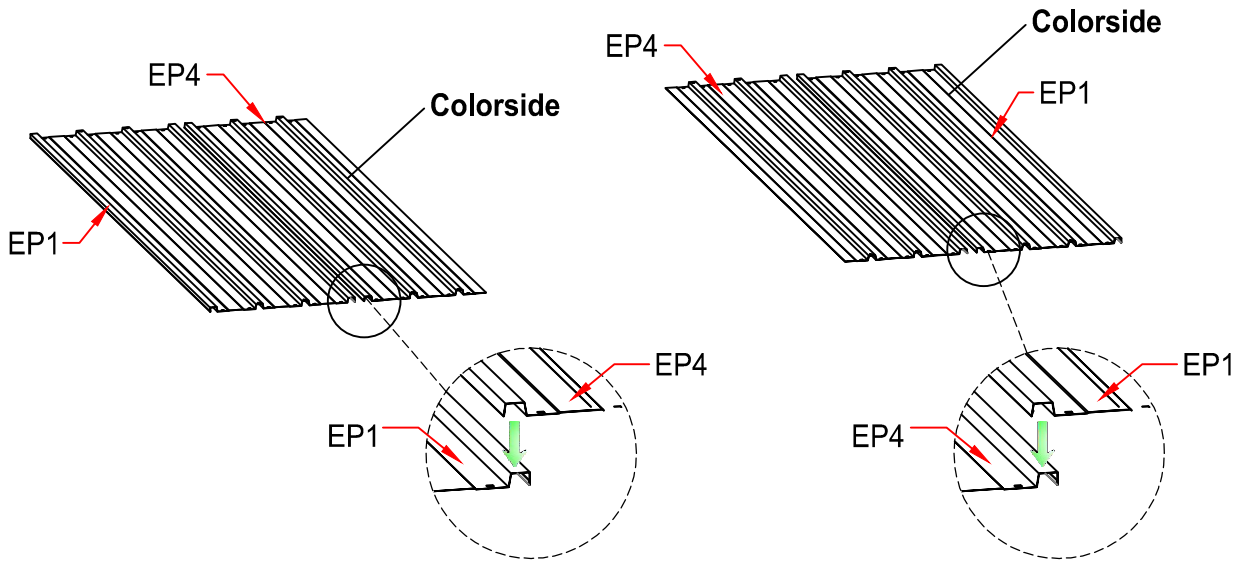

## STEP2

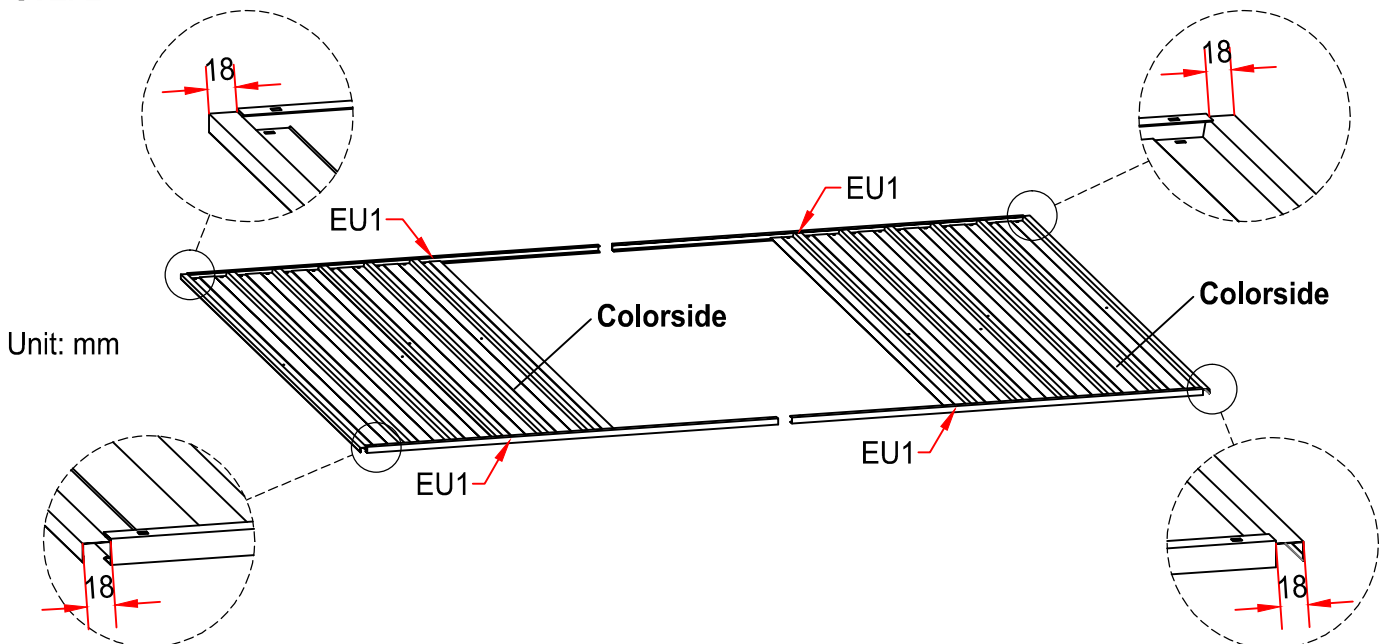

# PANEL ASSEMBLY STEP3-4 FRONT WALLS

## STEP3

Unit: mm

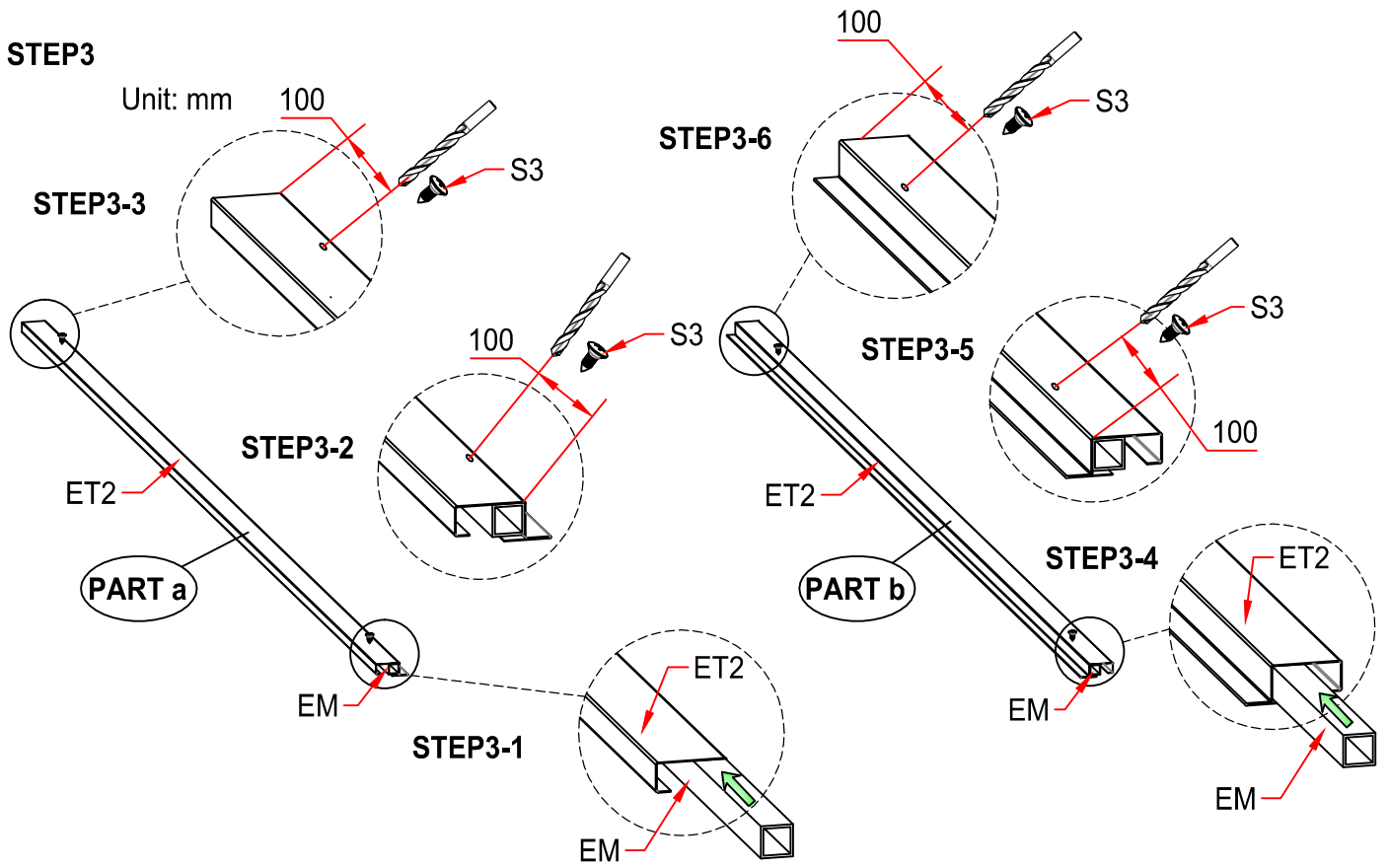

## STEP4

### STEP4-1 PART a insert EU1

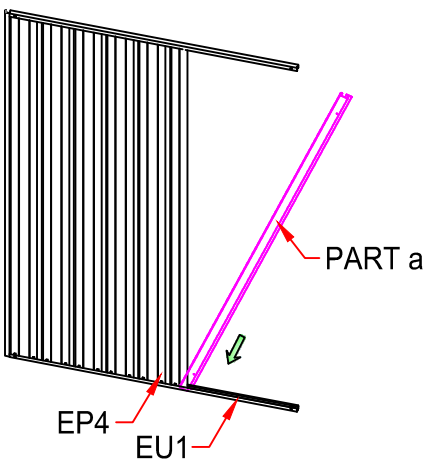

### STEP4-2

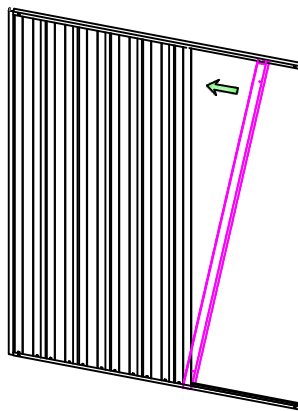

### STEP4-3

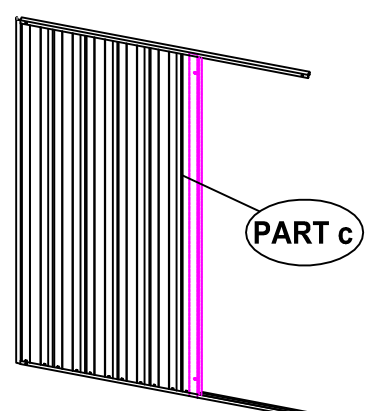

# PANEL ASSEMBLY STEP4-6 FRONT WALLS

## STEP4

STEP4-4 PATR b insert EU1

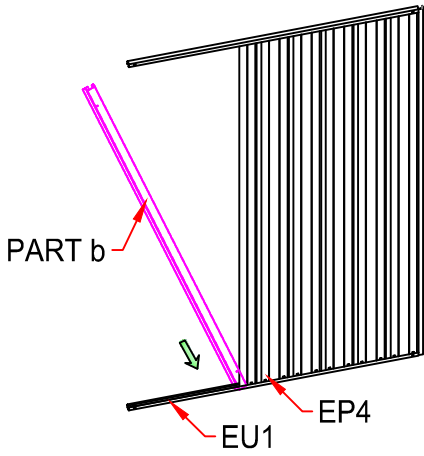

STEP4-5

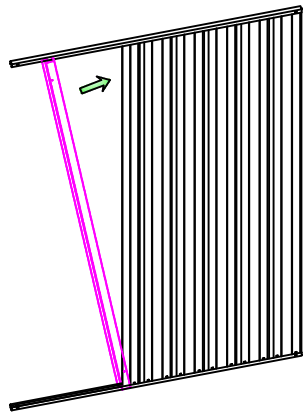

STEP4-6

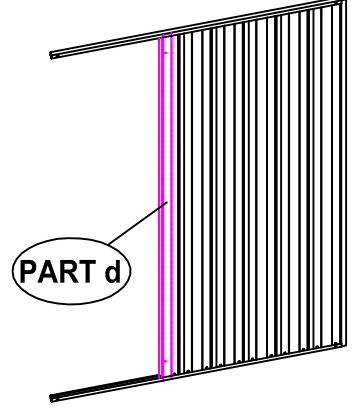

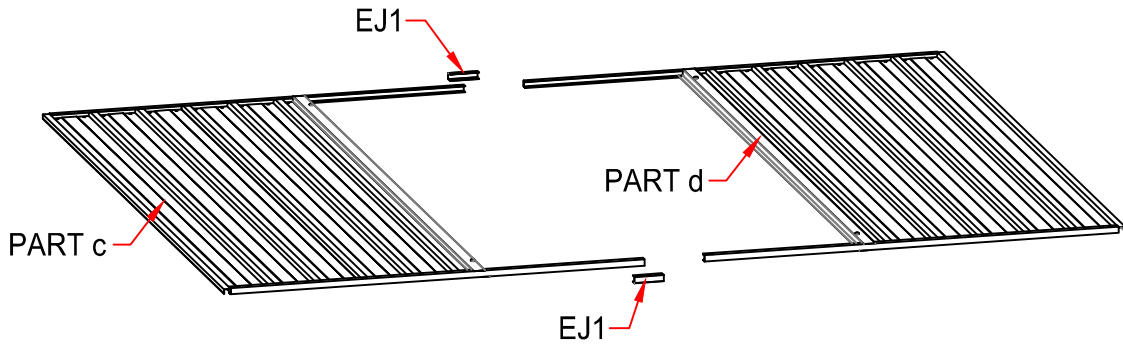

## STEP5

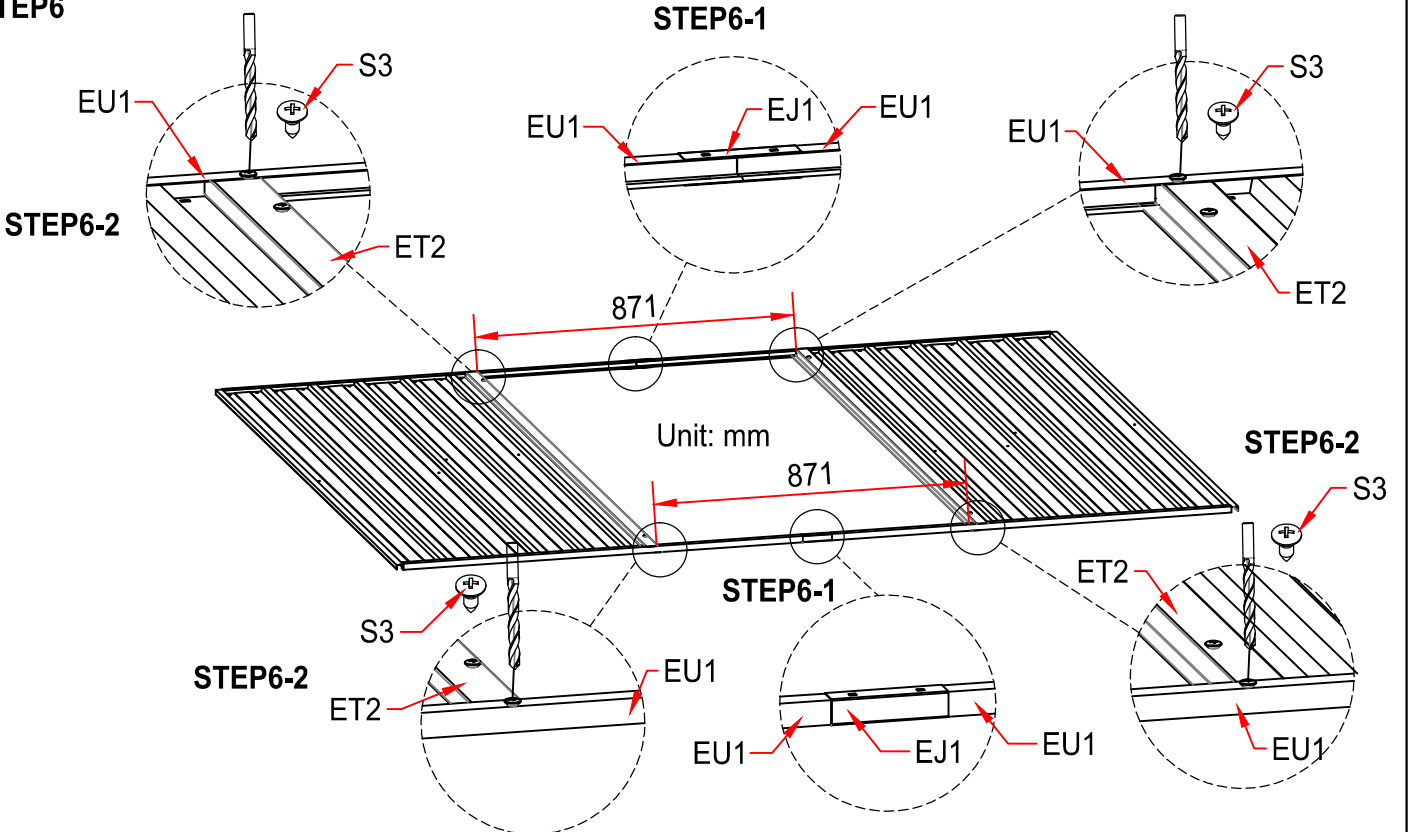

## STEP6



# SHED ASSEMBLY JOINING WALLS



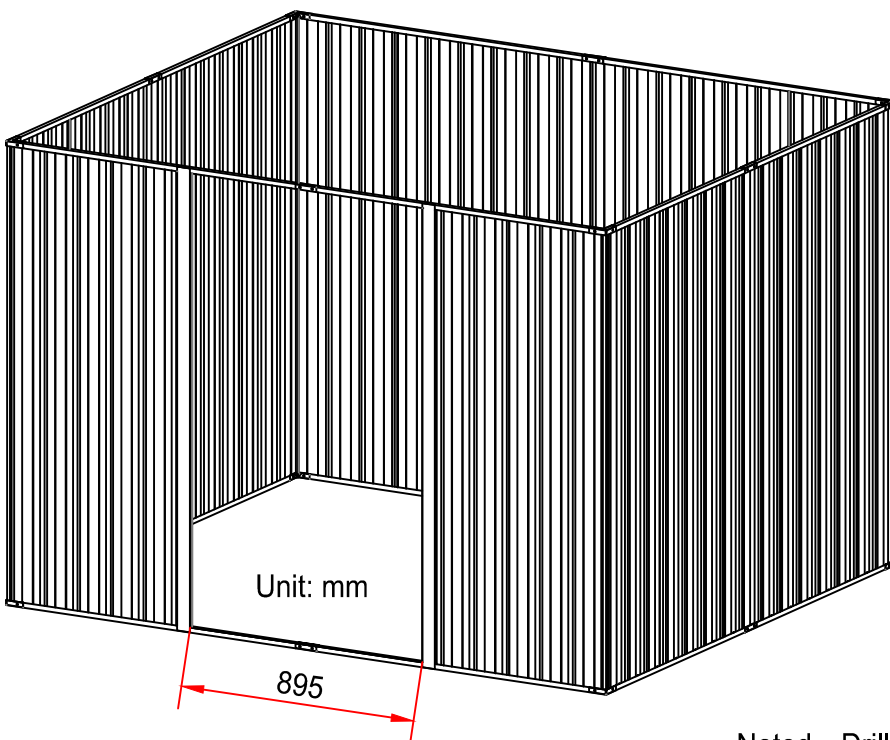
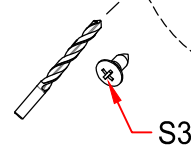
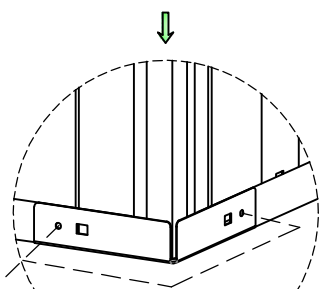
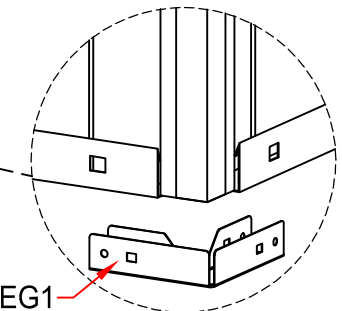
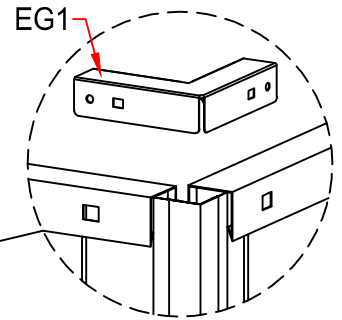
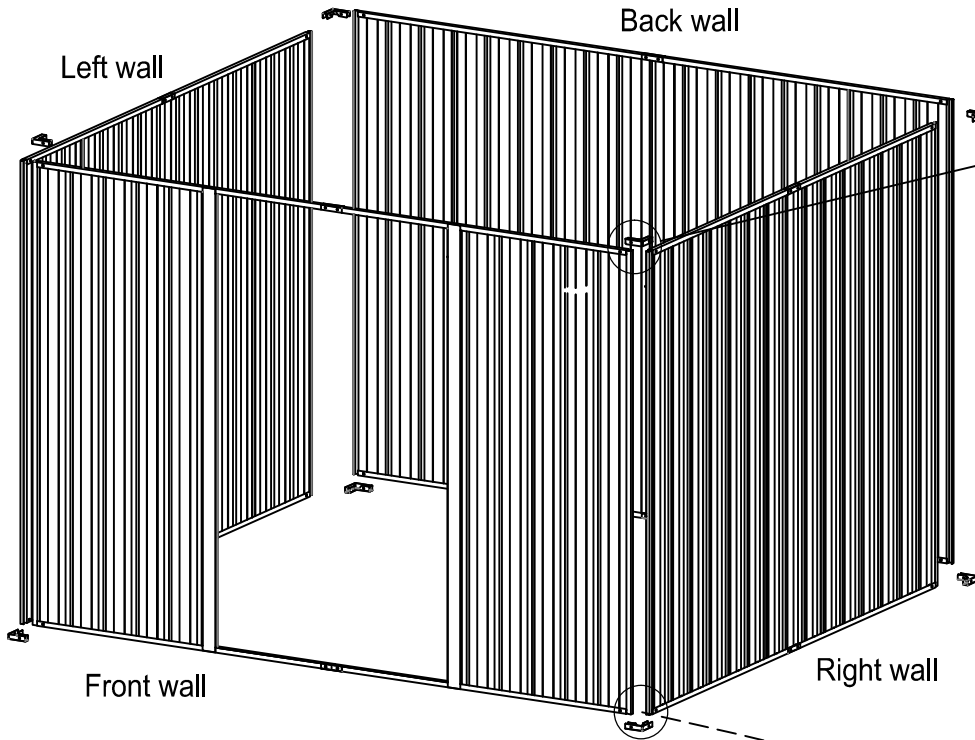

	EG1	8		S3	32
---	-----	---	---	----	----

Noted: Drill S3 on both sides to improve the stability of connector



Noted: Drill S3 on both sides to improve the stability of connector

# ANCHORING ASSEMBLY

	EC1	8		S11	8		S3	16		L3	16
---	-----	---	---	-----	---	---	----	----	---	----	----

## STEP1

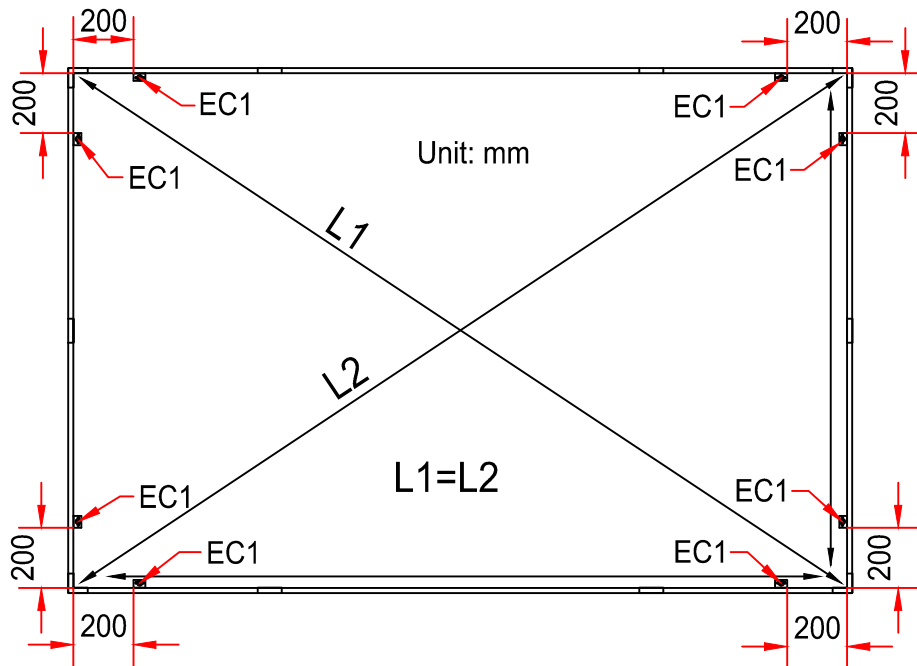

1. The shed is now free standing. It is critical at this stage to ensure the shed is levelled.
2. Then measure the diagonal distance and make sure the four side walls are squared to 90 degrees.
3. Use anchor kit (EC1 & S11) when fixing to a concrete base. Fastening the anchor kit onto a concrete pad
  - 3.1 Mark the place of the anchor on the ground.
  - 3.2 Use 10mm -0.39" concrete drill bit and drill holes 60mm-2.4" deep.
  - 3.3 Tap concrete fixing bolts into the hole, place anchor, add washer and nut and fasten.

## STEP2

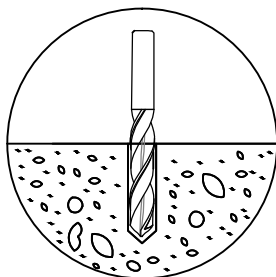

## STEP3

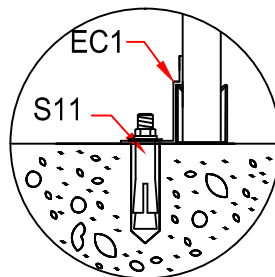

## STEP4

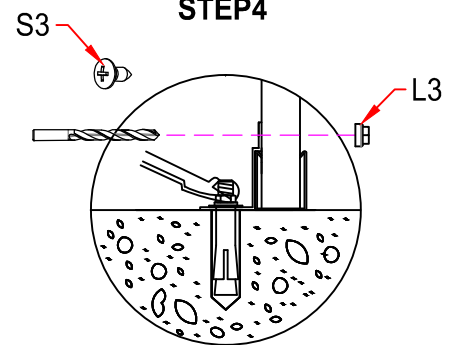

# SHED ASSEMBLY JOINING WALLS

	S3	8
---	----	---





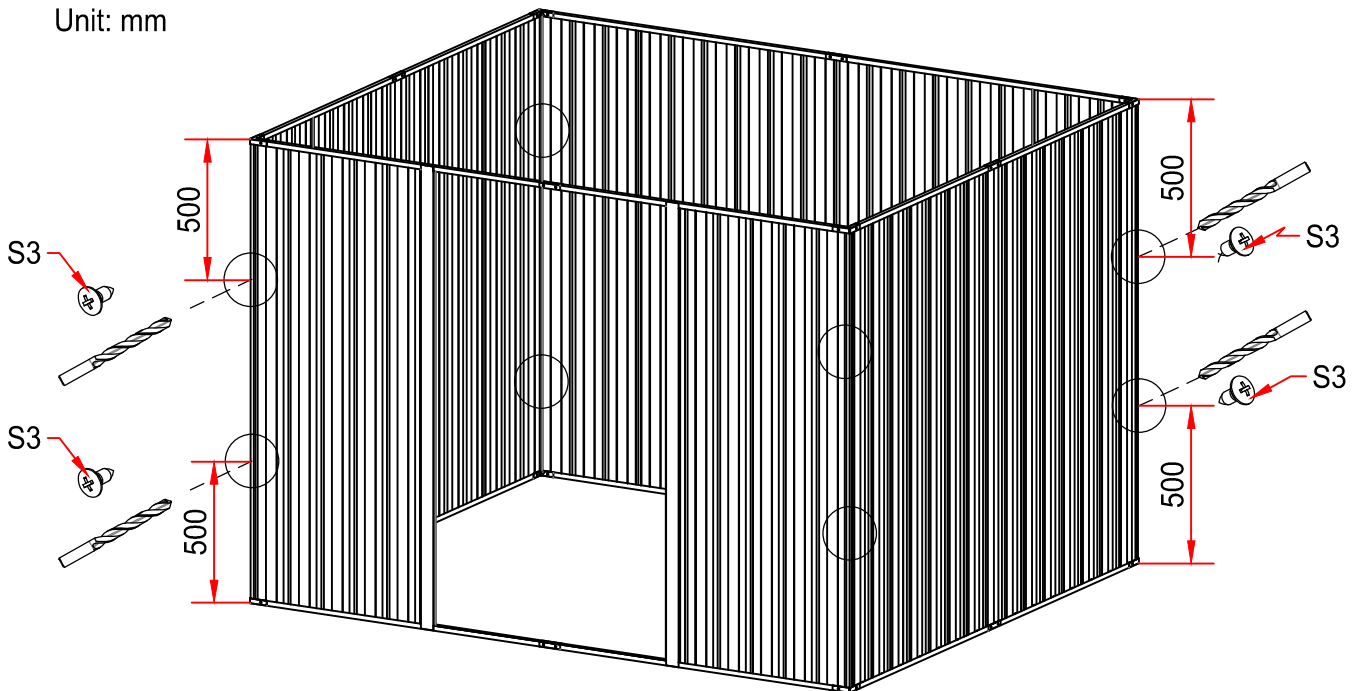







Noted: Use S3 to fix the corner and make the wall firm and avoid sunlight getting in.

Unit: mm















# SHED ASSEMBLY FRONT DOORS

Left Door

	EDL	1		S7	17
	EA1	2		S16	3
	EH	1		PH1	1
	M4	6		PH2	1
	SH1	3		PH3	1
	UV	1		MSB	3

Right Door

	EDR	1		S7	17
	EA1	2		S16	3
	EH	1		PH1	1
	M4	6		PH2	1
	SH1	3		PH3	1
	UV	1		MSB	3

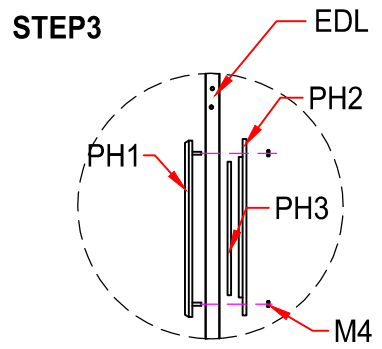
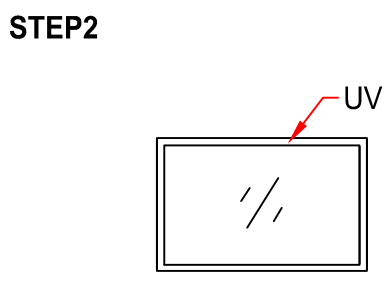
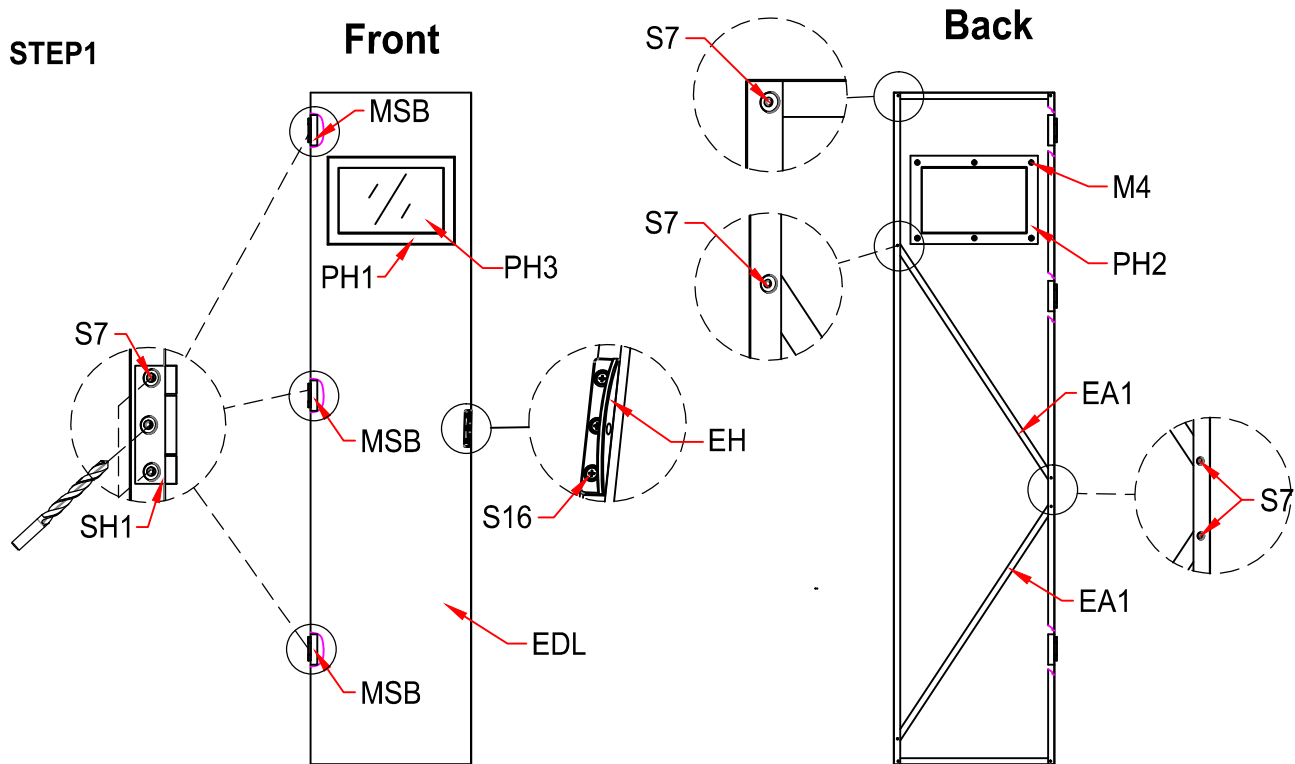

Noted:  
Paste UV on bothsides of PH3.

# SHED ASSEMBLY DOOR FRAME

	EU3	1		ET1	1		S3	4
---	-----	---	---	-----	---	---	----	---

STEP1

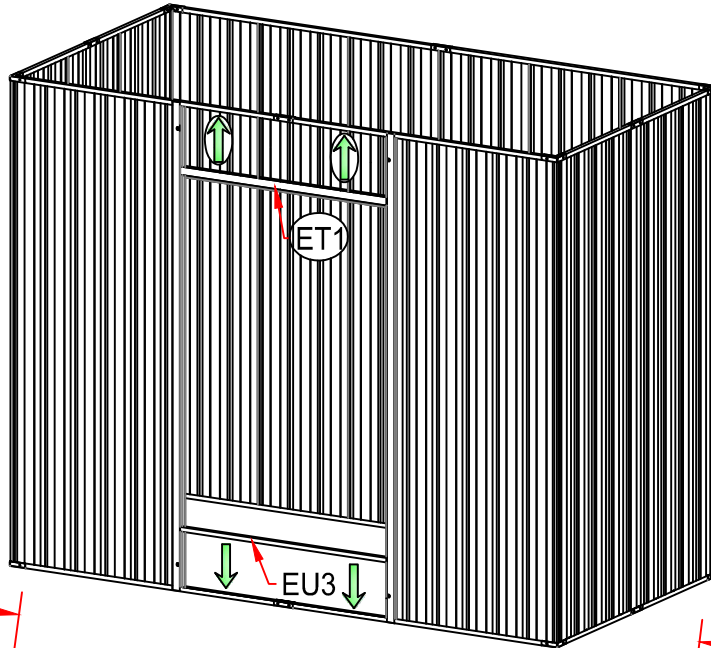

STEP2

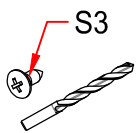
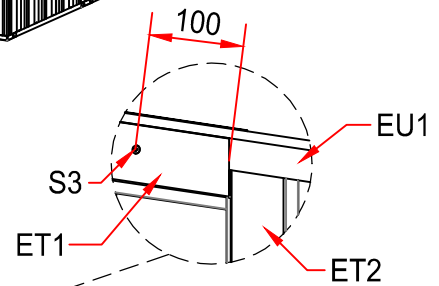
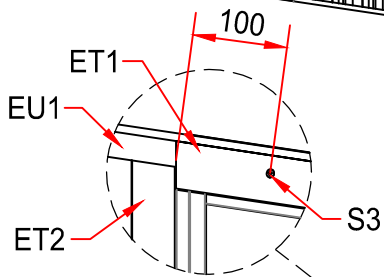



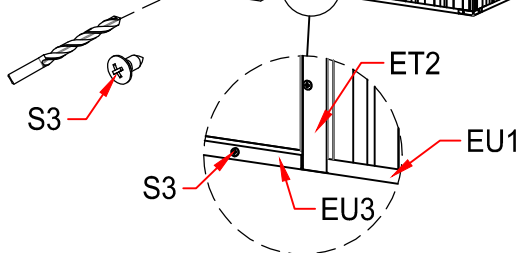
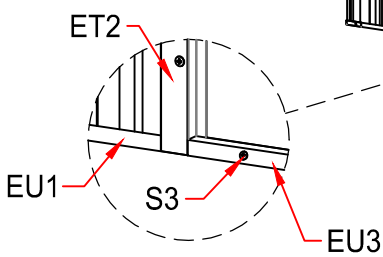

STEP3



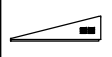

# SHED ASSEMBLY TRIANGLE

	EV2	4		EGL1	2		S3	16		EGR1	2		L3	4
---	-----	---	---	------	---	---	----	----	--	------	---	---	----	---

**STEP1**

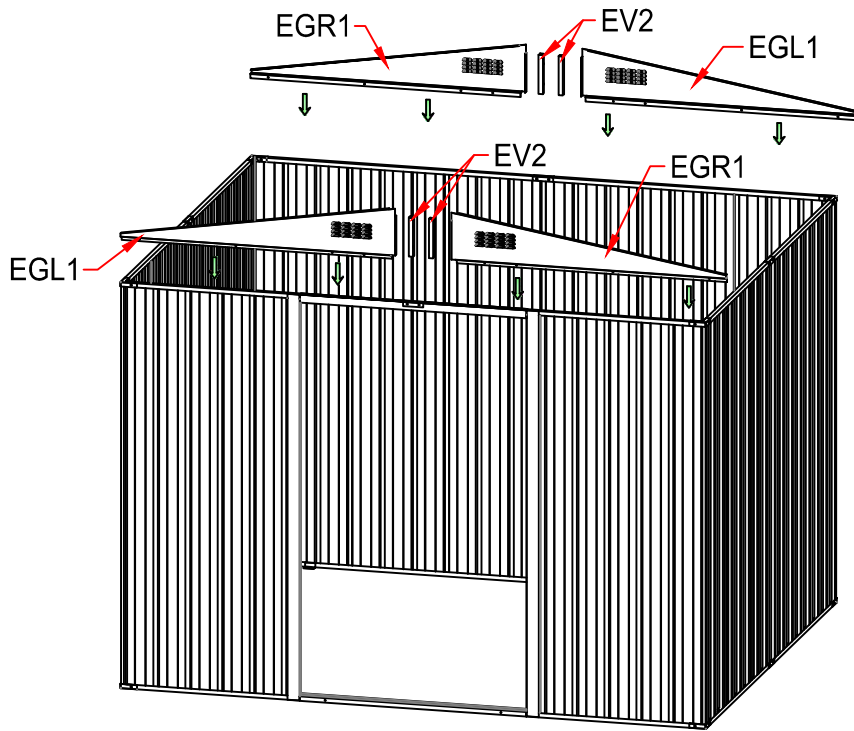

**STEP2**

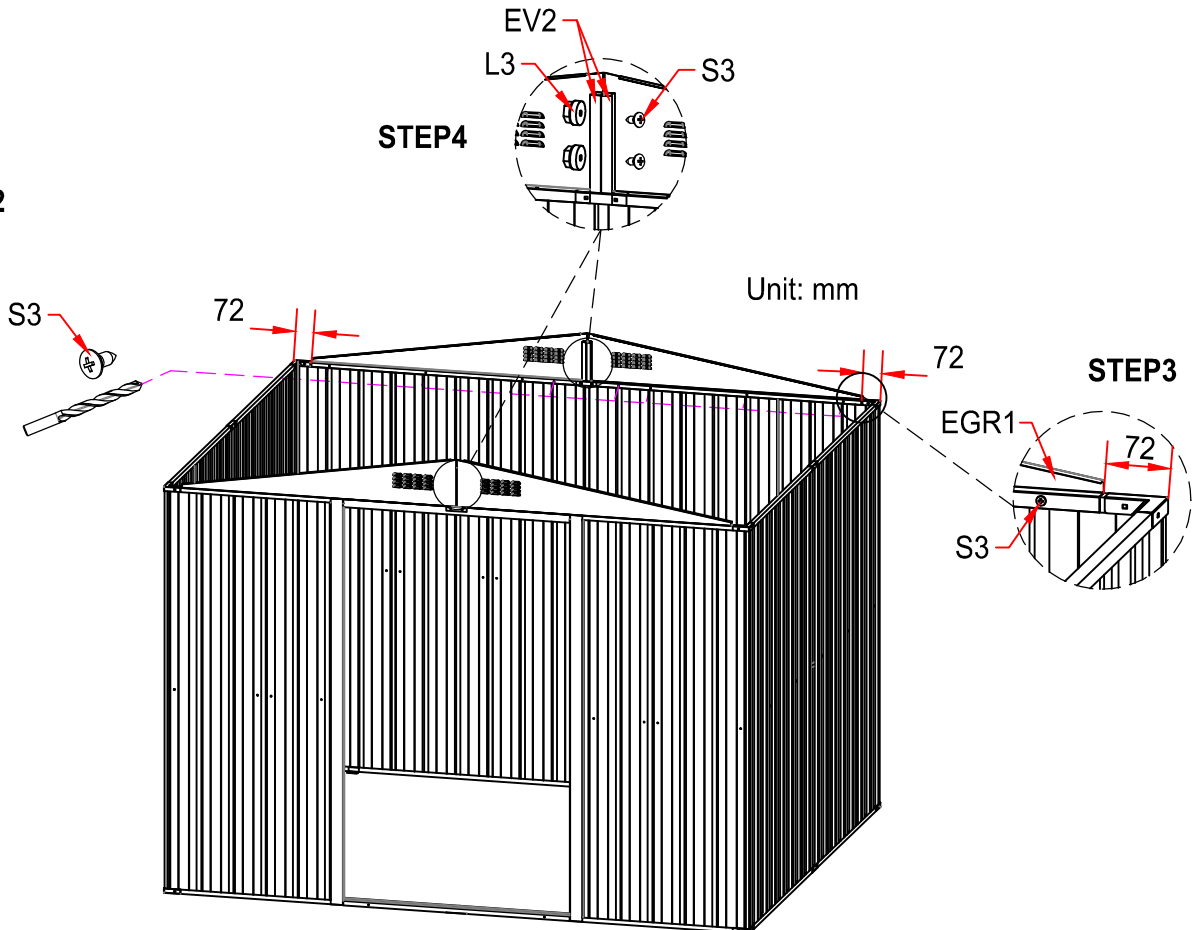

# SHED ASSEMBLY FRONT DOORS



	S7	24		H2	1		H3	1		H1B	1
---	----	----	---	----	---	---	----	---	---	-----	---

Noted:

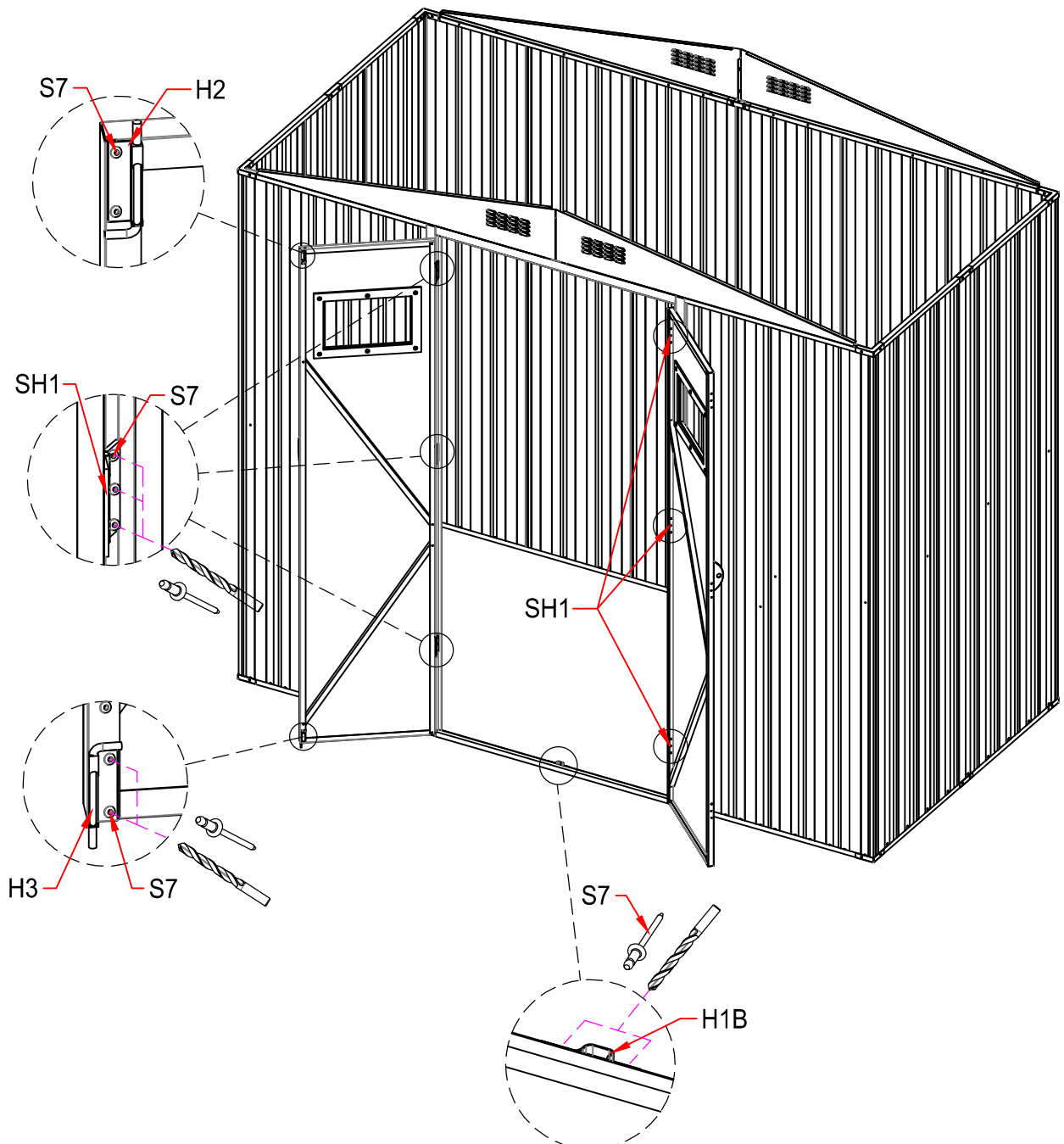
1. Adjust the door to proper position and mark in place, then drilling the holes of hinges and fixing them.
2. The hinges of left and right door are consistent.

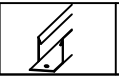

# SHED ASSEMBLY MAIN BEAM

	EV1	1		EV4	2		S3	8		L1A	4
---	-----	---	---	-----	---	---	----	---	--	-----	---

## STEP1

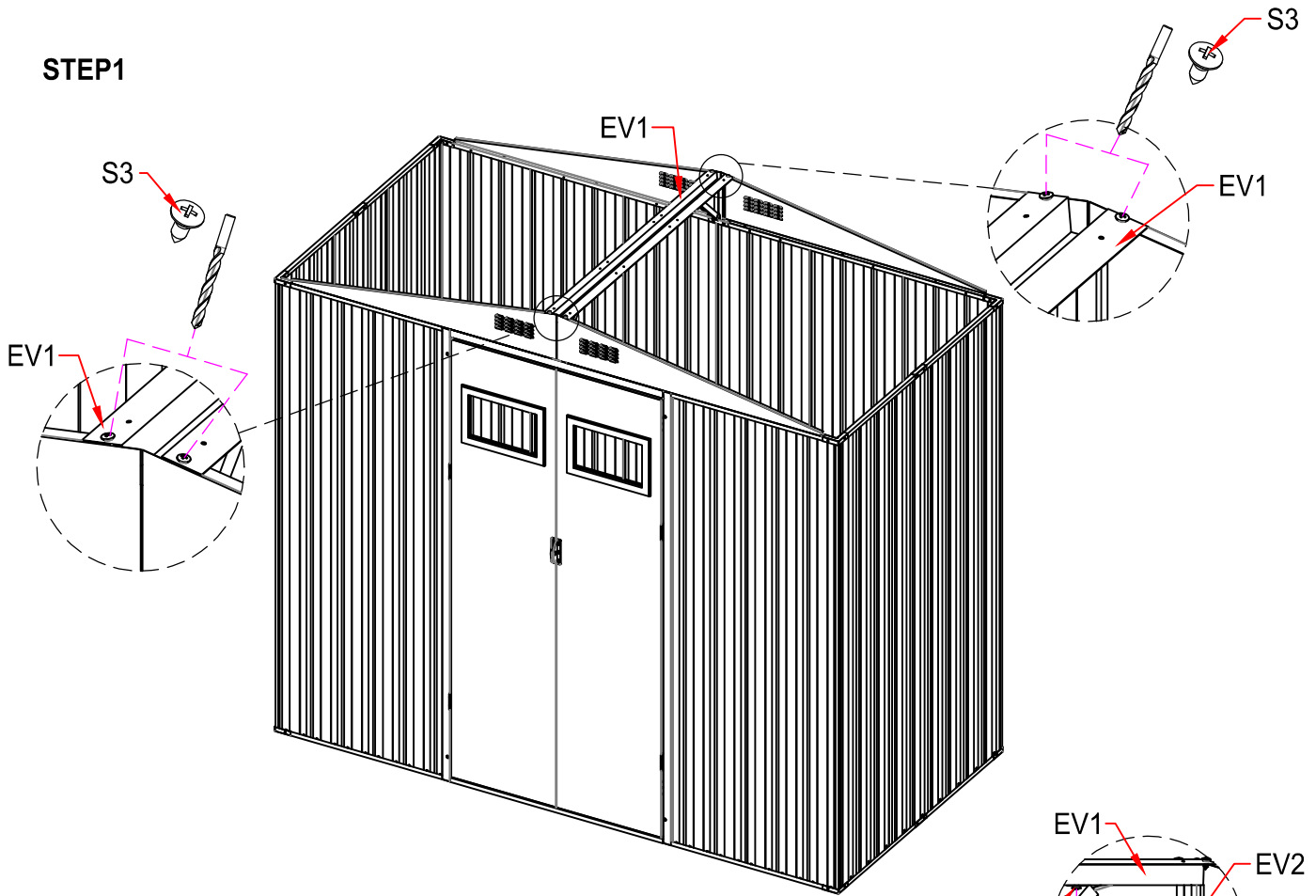



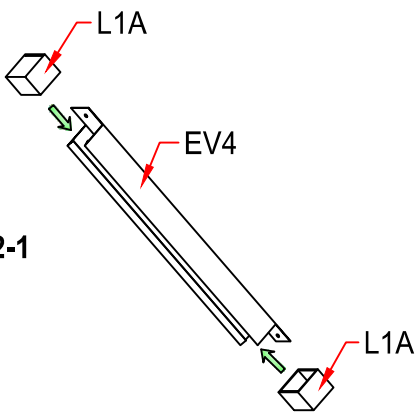

## STEP2

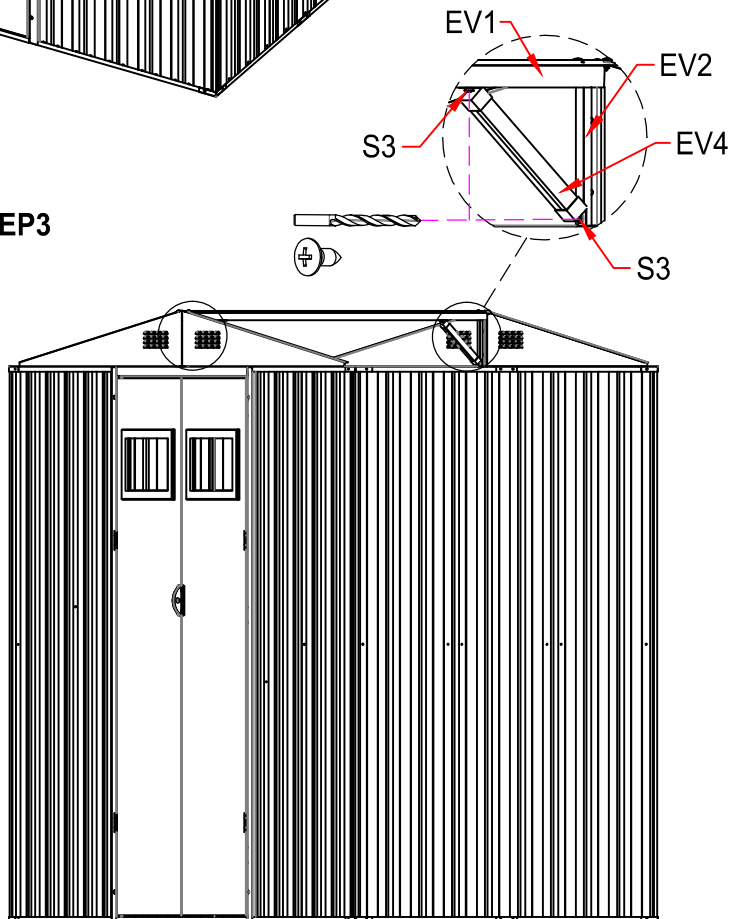

## STEP3



# SHED ASSEMBLY ROOF PANELS

	EP2	6		ER1	1		ER2	1		S3	28
---	-----	---	---	-----	---	---	-----	---	---	----	----

## STEP1

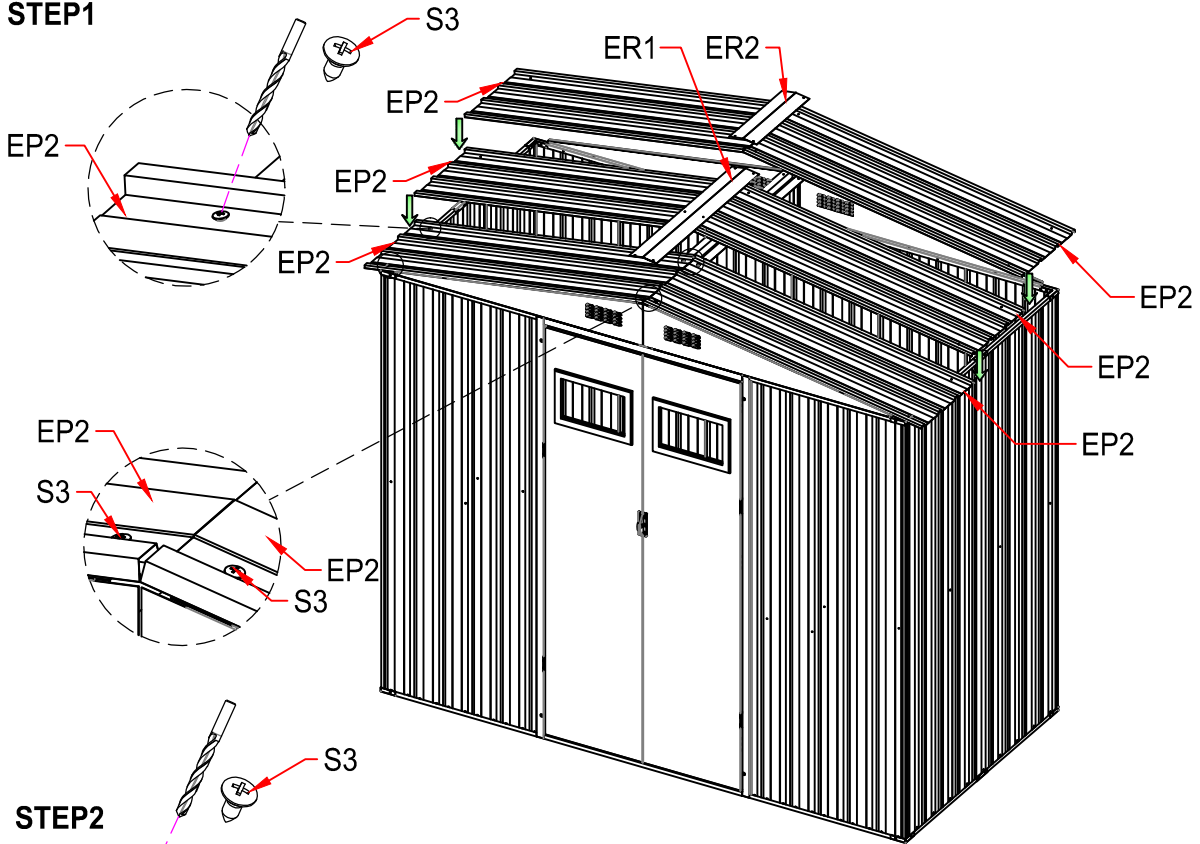

## STEP2

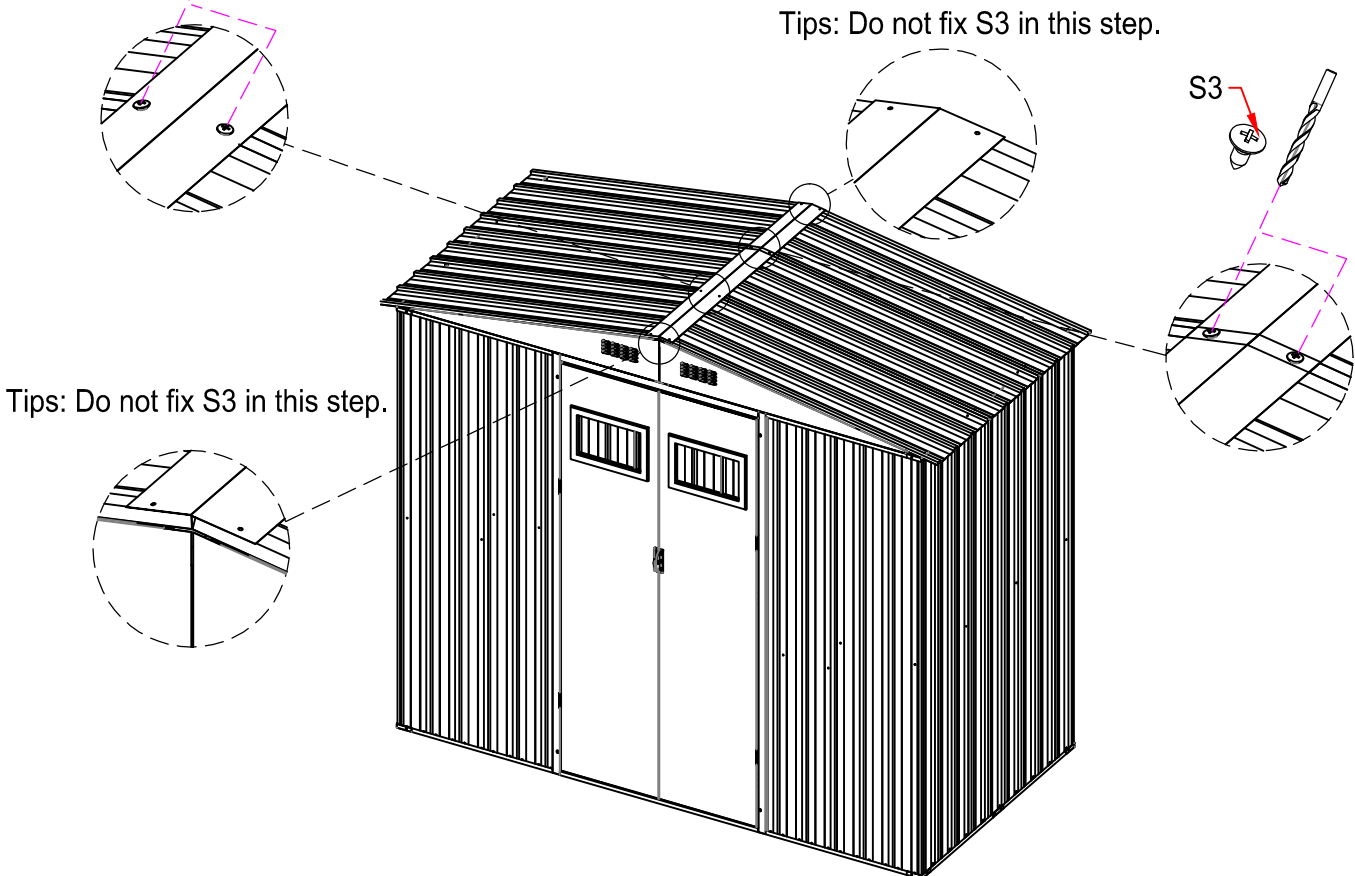

# SHED ASSEMBLY EAVES & LOGOS

	ETL1	4		ETL2	2		ETL3	2		ELG	2		S3	18
---	------	---	---	------	---	---	------	---	--	-----	---	---	----	----

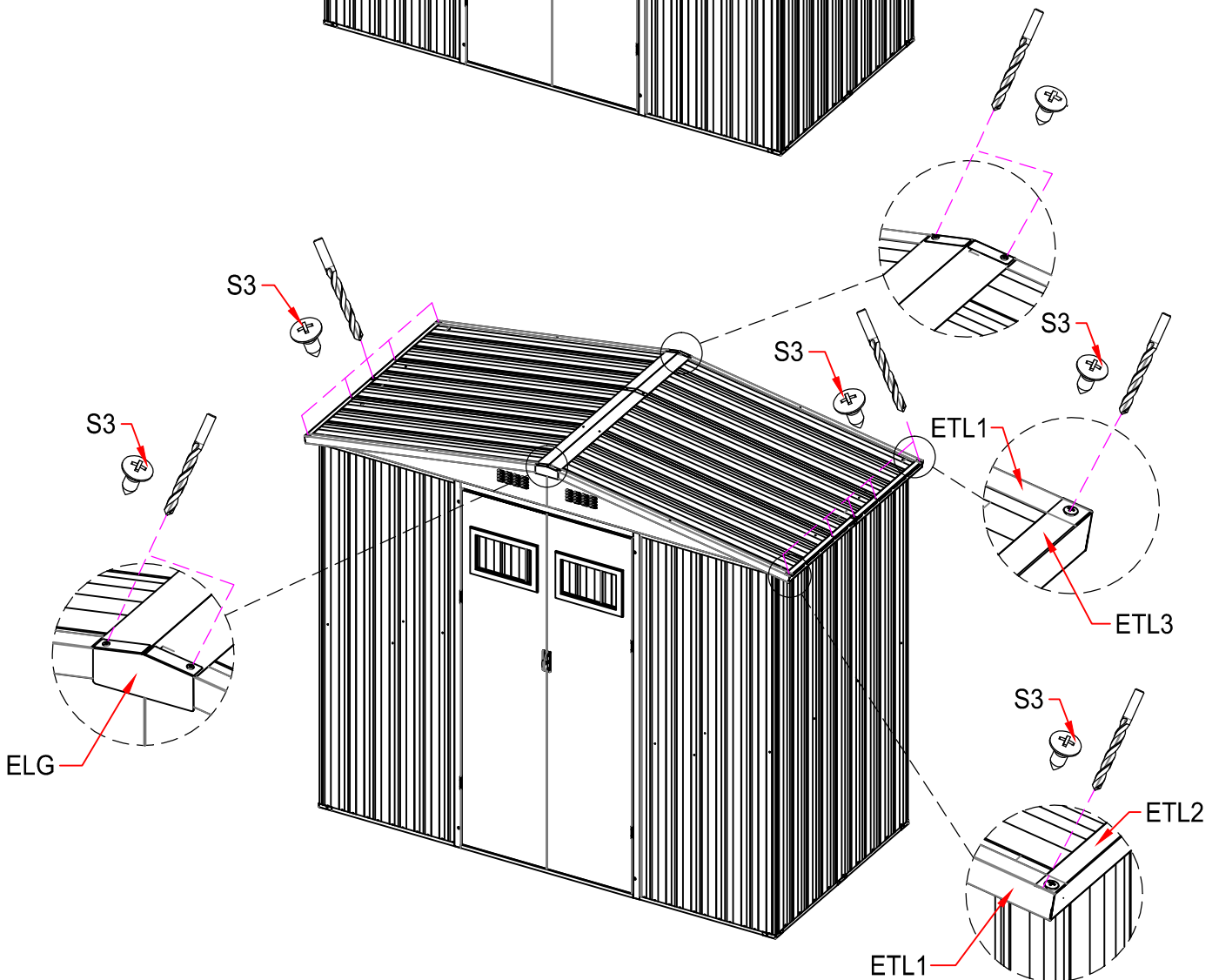
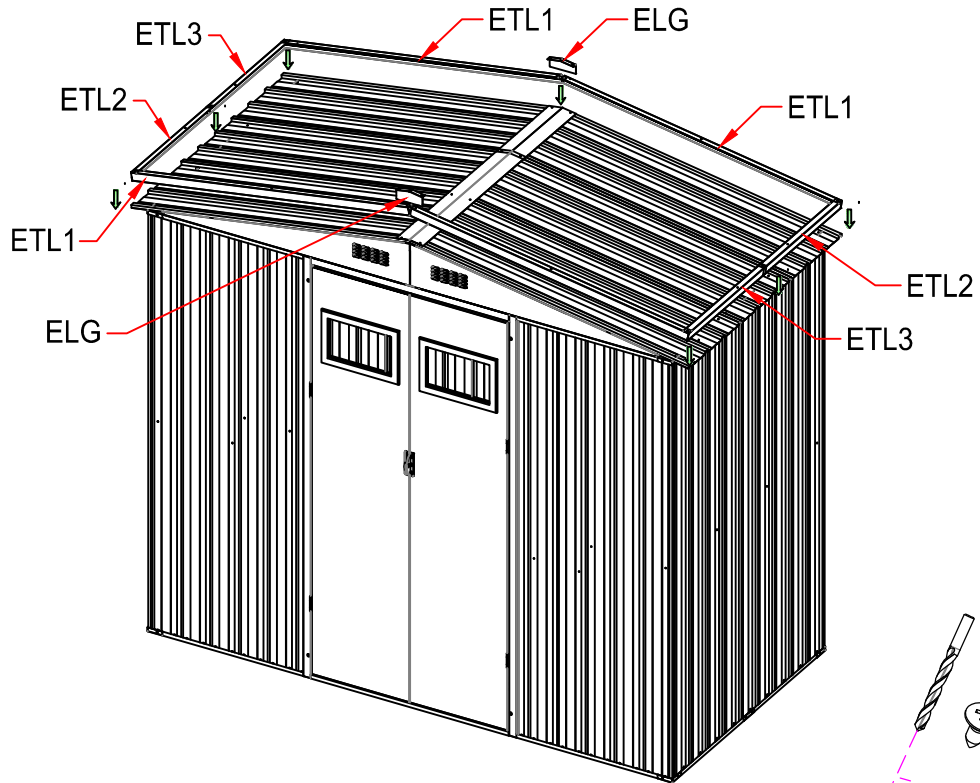

# PROTECTION

	L3	16
---	----	----

