

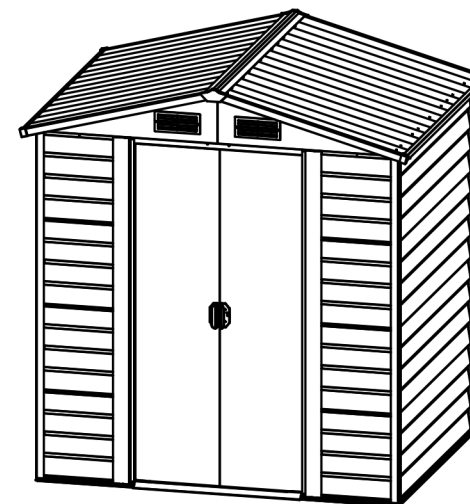

INbcb008_UK_FR_DE_IT_845-172

Metal Garden Shed
Metall Gartenschuppen
Hangar de jardin en métal
Casetta da Giardino in Metallo



OWNER'S MANUAL

Instructions for Assembly

BEDIENUNGSANLEITUNG

Aufbauanleitung

LE MANUEL DU PROPRIÉTAIRE

Instructions de montage

MANUALE DEL PROPRIETARIO

Istruzioni per l'Assemblaggio

Richiede due persone e 2-3 ore per l'installazione
Montaggio facile e veloce
Pareti rinforzate
Disponibile in varie dimensioni

Requires two people and takes
2-3 hours for Installation.

Quick & Easy Assembly

Ridge Reinforced Walls

Available in Various Sizes

Benötigt zwei Personen und dauert
2-3 Stunden für die Installation.

Schnelle und einfache Montage

Verstärkte Wände

Erhältlich in verschiedenen Größen

Nécessite deux personnes et prend
2-3 heures pour l'installation.

Assemblage rapide et facile

Murs renforcés de faîte

Disponibile en différentes tailles

BEFORE YOU START

Owner's Manual

Prior to installation, it is important that you contact your local government authority to determine if building approval is required. Study and understand this owner's manual. Important information and helpful tips will make your construction easier and more enjoyable.

Assembly instructions

Instructions are supplied in this manual and contain all appropriate information for your building model. Review all instructions before you begin. During assembly, follow the step sequence carefully for correct results. Please be aware: **this unit takes two people about one full day to complete.**

Parts

Check to be sure that you have all the necessary parts for the building.

Separate contents of the carton by the part number while reviewing parts list.

Familiarize yourself with the hardware and fasteners for easier use during construction. These are packaged within the carton. Note that extra fasteners have been supplied for your convenience.

TOOLS MAY REQUIRED

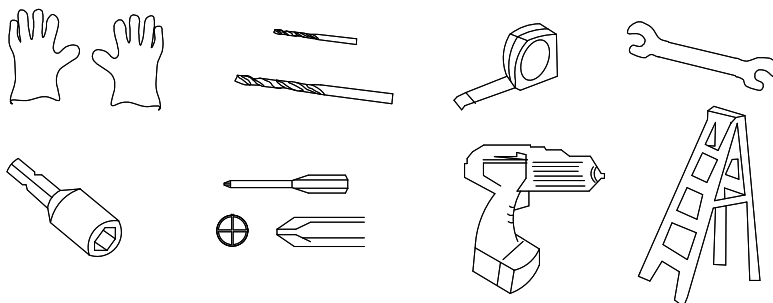

Use heavy duty gloves when handling steel sheets and flashing

PLAN AHEAD

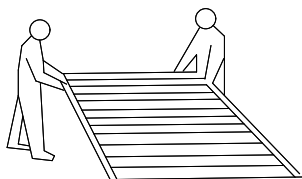

It requires two people a full day to complete installation

Watch the weather:

Please be sure the day you select for installation is dry and calm.

DO NOT attempt to assemble your shed in windy weather because of risk of damage to panels, or personal injury. Be careful of wet or muddy ground.

Teamwork:

Whenever possible, two or more people should work together to assemble the building. One person can position parts or panels while the other is able to handle the fasteners and the tools.

PLAN AHEAD

Site Selection

- Avoid overhanging trees as much as possible as leaves will make regular cleaning necessary and broken branches are a potential hazard.
- Small trees, bushes or fences nearby can be helpful, acting as a wind break.

Site Preparation

The site must be prepared so that the base of the shed is level all round and checking with a spirit level is required.

The base can be constructed by treated timber or concrete, in order to stop the moisture getting into the shed. **The shed is not designed to be built onto lawn directly.** Also the ground will get muddy during rainy days.

If a concrete pad is made, it is important that this slopes towards the edges to prevent water ingress.

Time must be allowed for any concrete or cement to dry before building the shed on top.

Bases can also be constructed from bricks, blocks, or mounted on a concrete pad.

The bricks or blocks should be cemented onto firm and level concrete footings and the greenhouse frame drilled and screwed to the base.

IMPORTANT NOTES:

- Find someone to help you: it is much easier with someone to hold parts, pass tools ect. Also some steps require two people to lift structures together. This is not very heavy work so would suit most able-bodied people.
- Allow plenty of time: rushing often causes errors and the re-doing of incorrect assemblies. If you have never built a shed before, it can take most of a day to carefully complete the construction.
- Have the right tools to hand.
- Safety clothing as recommended in the 'Tools' section.
- Ideally lay out the parts and check that all are present before commencing construction. Lay on cloths or plastic sheets if there is any risk of scratching the parts.
- Tighten all nuts carefully, being sure not to miss any. Check the frame is square and using a spirit level to check that it is upright.

BEVOR SIE ANFANGEN

Bedienungsanleitung

Vor der Installation ist es wichtig, dass Sie sich an Ihre lokale Regierungsbehörde wenden, um festzustellen, ob eine Gebäudegenehmigung erforderlich ist. Lesen Sie diese Bedienungsanleitung sorgfältig. Wichtige Informationen und hilfreiche Tipps helfen Ihnen dabei den Aufbau einfacher und angenehmer zu gestalten.

Montageanleitung

In diesem Handbuch finden Sie Anweisungen, die alle relevanten Informationen für Ihr Gebäudemodell enthalten. Überprüfen Sie alle Anweisungen, bevor Sie beginnen. Befolgen Sie bei der Montage sorgfältig die Schrittfolge, um korrekte Ergebnisse zu erzielen. Bitte beachten Sie: Bei diesem Gerät benötigen zwei Personen ungefähr einen ganzen Tag um den Aufbau zu komplettieren.

Zubehör

Vergewissern Sie sich, dass Sie alle notwendigen Teile für das Gebäude haben. Trennen Sie den Inhalt des Kartons durch die Teilenummer, während Sie die Zubehörliste überprüfen. Machen Sie sich mit den Einzelteilen und den Befestigungselementen vertraut, um die Konstruktion zu vereinfachen. Diese sind im Karton verpackt. Beachten Sie, dass zusätzliche Befestigungen für Ihre Bequemlichkeit zur Verfügung gestellt wurden.

ERFORDERLICHE WERKZEUGE

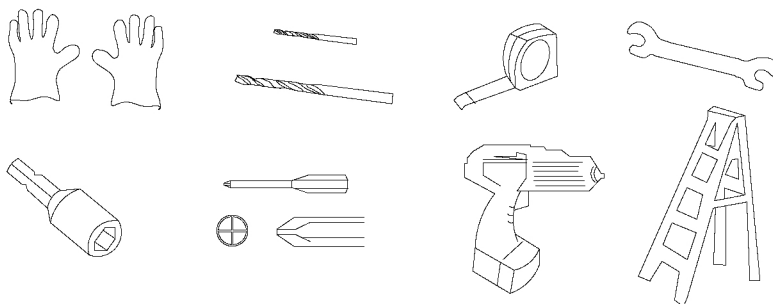

Verwenden Sie Arbeitshandschuhe beim Umgang mit Stahlblechen.

VORAUPLANEN

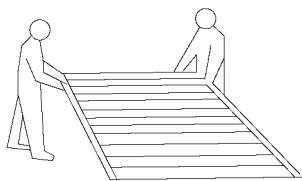

Der Aufbau benötigt einen ganzen Tag für zwei Leute.

Beachten Sie das Wetter:
Stellen Sie sicher, dass es nicht regnet am Tag des Aufbaus.
Bauen Sie den Schuppen NICHT auf falls es windig ist
Wind kann ein Risiko darstellen und eine Beschädigung der Platten oder Personenverletzung herbeiführen.

Teamarbeit:

Wenn möglich, sollten zwei oder mehr Personen zusammenarbeiten

Eine Person kann Teile oder Platten positionieren, während die andere die Befestigungsmittel und die Werkzeuge handhaben kann.

VORAUPLANEN

Standortauswahl

·Vermeiden Sie den Schuppen unter Bäumen aufzubauen, da herunterfallende Blätter und Dreck die Reinigung erschweren.

·Kleine Bäume, Büsche oder Zäune in der Nähe des Schuppen können als Windschutz dienen und sind empfehlenswert.

Standortvorbereitung

Der Aufstellungsort muss so vorbereitet sein, dass die Basis des Schuppens rundherum eben ist. Eine gründliche Überprüfung mit einer Wasserwaage ist erforderlich. Die Basis kann aus behandeltem Holz oder Beton bestehen, um dem Eindringen von Feuchtigkeit in den Schuppen vorzubeugen. Der Schuppen ist nicht dafür ausgelegt, direkt auf Rasen gebaut zu werden, da der Boden an regnerischen Tagen schlammig werden kann.

Wenn eine Betonplatte genutzt wird, ist es wichtig, dass diese gegen die Kanten geneigt ist, um das Eindringen von Wasser zu verhindern.

Vor dem Bau des Schuppens muss Zeit für das Trocknen von Zement oder Beton eingeplant werden.

Die Basis kann auch aus Ziegeln, Blöcken oder Betonplatten bestehen. Die Ziegel oder Blöcke sollten auf einem festen und ebenen Betonfundament befestigt und der Schuppenrahmen mit der Basis verschraubt werden.

WICHTIGE HINWEISE:

·Finden Sie jemanden, der Ihnen hilft: der Aufbau ist viel einfacher mit einer weiteren Person, z. B. um Teile zu halten, Werkzeuge usw. zu übergeben. Auch erfordern einige Schritte zwei Personen, um Strukturen zusammen zu heben. Die Arbeit ist nicht übermäßig schwer oder kompliziert und kann den meisten Personen zugetraut werden.

·Erlauben Sie ausreichend Zeit für den Aufbau: Überstürzung oder Eile kann Fehler und in manchen Fällen einen Wiederaufbau verursachen. Falls Sie keine Erfahrung mit dem Aufbau von ähnlichen Strukturen haben, kann es fast einen ganzen Tag dauern um den Aufbau zu komplettieren.

·Habe die richtigen Werkzeuge zur Hand.

·Sicherheitsbekleidung, wie im Abschnitt "Werkzeuge" empfohlen.

·Stellen Sie vor Beginn der Konstruktion sicher ob alle Einzelteile und Zubehör vorhanden sind. Legen Sie sie auf Tücher oder Plastikplanen, wenn die Gefahr besteht, dass die Teile zerkratzt werden könnten.

·Ziehen Sie alle Muttern sorgfältig fest und achten Sie darauf, dass keine fehlen. Überprüfen Sie, ob der Rahmen quadratisch ist und prüfen Sie mit einer Wasserwaage, dass er aufrecht steht.

AVANT DE COMMENCER

Le manuel du propriétaire

Avant l'installation, il est important que vous contactiez votre autorité gouvernementale locale pour déterminer si l'approbation de la construction est requise. Étudiez et comprenez ce manuel du propriétaire. Des informations importantes et des conseils utiles rendront votre construction plus facile et plus agréable.

Instructions de montage

Les instructions sont fournies dans ce manuel et contiennent toutes les informations appropriées pour votre modèle de bâtiment. Passez en revue toutes les instructions avant de commencer. Lors de l'assemblage, suivez attentivement la séquence des étapes pour obtenir des résultats corrects. Sachez que cette unité prend deux personnes environ une journée complète à compléter.

Les pièces

Vérifiez pour être sûr que vous avez toutes les pièces nécessaires pour le bâtiment. Séparer le contenu du carton par le numéro de pièce lors de l'examen de la liste des pièces. Si un tampon en béton est fabriqué, il est important que celui-ci soit incliné vers les bords pour empêcher l'infiltration d'eau. Il faut laisser du temps à tout béton ou ciment avant de construire le hangar. Familiarisez-vous avec le matériel et les fixations pour une utilisation plus facile pendant la construction. Ceux-ci sont emballés dans le carton. Notez que des attaches supplémentaires ont été fournies pour votre commodité.

DES OUTILS SONT PEUT ETRE NECESSAIRES

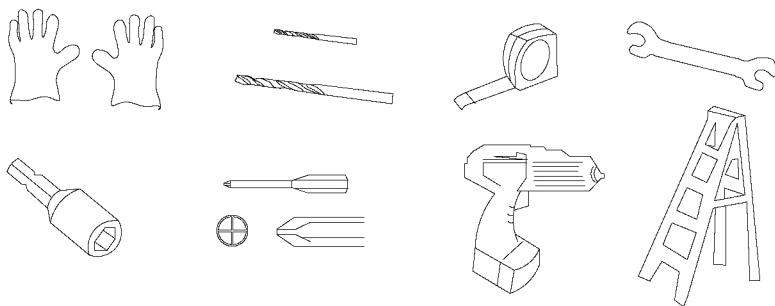

Utiliser des gants résistants pour manipuler les tôles d'acier et les solins

PLANIFIER À L'AVANCE

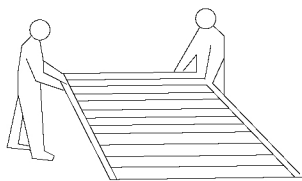

Il faut deux personnes par jour pour terminer l'installation.

Regarder la météo: assurez-vous que le jour choisi pour l'installation est sec et calme. N'essayez PAS d'assembler votre remise par temps venteux en raison du risque d'endommagement des panneaux ou de blessures. Faites attention au sol humide ou boueux.

Travail en équipe: chaque fois que possible, deux personnes ou plus devraient travailler ensemble pour assembler le bâtiment. Une personne peut positionner des pièces ou des panneaux tandis que l'autre est capable de manipuler les attaches et les outils.

PLANIFIER À L'AVANCE

Sélection du site

Évitez autant que possible les arbres en surplomb, car les feuilles nettoieront régulièrement les branches nécessaires et brisées sont un danger potentiel. Les petits arbres, les buissons ou les clôtures à proximité peuvent être utiles, agissant comme un brise-vent.

Préparation du site

Le site doit être préparé de manière à ce que la base de la remise soit de niveau et il faut vérifier avec un niveau à bulle.

La base peut être construite en bois traité ou en béton, afin d'empêcher l'humidité de pénétrer dans le hangar. Le hangar n'est pas conçu pour être construit directement sur la pelouse. De plus, le sol devient boueux pendant les jours de pluie.

Si un tampon en béton est fabriqué, il est important que celui-ci soit incliné vers les bords pour empêcher l'infiltration d'eau.

Il faut laisser du temps à tout béton ou ciment avant de construire le hangar.

Les bases peuvent également être construites à partir de briques, de blocs ou montées sur un socle en béton. Les briques ou les blocs doivent être cimentés sur des semelles de béton fermes et de niveau et le châssis de la serre doit être percé et vissé à la base.

NOTES IMPORTANTES:

Trouver quelqu'un pour vous aider: il est beaucoup plus facile avec quelqu'un de détenir des pièces, passer des outils etc. Certaines étapes nécessitent également deux personnes pour soulever des structures ensemble. Ce travail n'est pas très lourd et conviendrait à la plupart des personnes non handicapées. Prévoyez beaucoup de temps: la précipitation entraîne souvent des erreurs et la répétition d'assemblages incorrects. Si vous n'avez jamais construit un hangar avant, il peut prendre une bonne partie de la journée pour compléter soigneusement la construction.

Avoir les bons outils à portée de main.

Vêtements de sécurité recommandés dans la section «Outils».

Idéalement, étalez les pièces et vérifiez qu'elles sont toutes présentes avant de commencer la construction. Poser sur des draps ou des feuilles de plastique s'il y a un risque de rayer les pièces.

Serrer soigneusement tous les écrous, en veillant à ne rien manquer. Vérifiez que le cadre est carré et qu'il est en position verticale en utilisant un niveau à bulle.

PRIMA DELL'INIZIO

Manuale del Proprietario

Prima di installare, è importante contattare l'autorità del governo locale per determinare se è necessaria l'approvazione edilizia. Studiare e comprendere il presente manuale del proprietario. Informazioni importanti e suggerimenti utili renderanno la costruzione più semplice e piacevole.

Istruzioni di Assemblaggio

Le istruzioni sono fornite in questo manuale e contengono tutte le informazioni appropriate per il modello di costruzione. Rivedere tutte le istruzioni prima di iniziare. Durante l'assemblaggio, seguire attentamente la sequenza dei passaggi per ottenere risultati corretti. Attenzione: questa unità ci impiega circa un giorno intero per essere completata.

Parti

Assicurarsi di avere tutte le parti necessarie per la costruzione della casetta.

Separare le parti dalla scatola in base al numero di parte con riferimento all'elenco delle parti.

Familiarizzarsi con l'hardware e gli elementi di fissaggio per un utilizzo più semplice durante la costruzione. Questi sono confezionati all'interno della scatola. Notare che sono forniti anche gli elementi di fissaggio aggiuntivi per la vostra comodità.

GLI STRUMENTI RICHIESTI

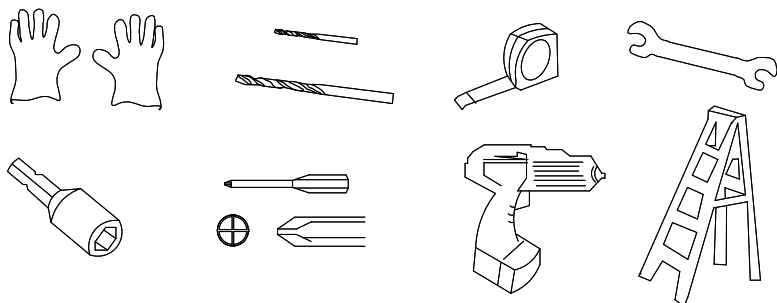

Usare guanti resistenti quando si maneggiano lamiere d'acciaio e foglio di copertura.

PIANIFICARE IN ANTICIPO

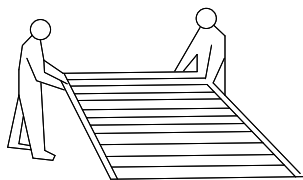

Richiede due persone in un'intero giorno per completare l'installazione

Attenzione al meteo:

Si prega di assicurarsi che il giorno selezionato per l'installazione sia asciutto e calmo. NON tentare di montare la casetta con tempo ventoso perché esiste il rischio di danni ai pannelli o di lesioni personali. Dare attenzione al terreno bagnato o fangoso.

Lavoro di squadra:

Quando possibile, due o più persone dovrebbero lavorare insieme per assemblare la casetta: una persona può posizionare parti o pannelli mentre l'altra è in grado di gestire i dispositivi di fissaggio e gli strumenti.

PIANIFICARE IN ANTICIPO

Selezione del sito

- Evitare il più possibile alberi sporgenti perché le foglie renderanno necessaria una pulizia regolare e i rami spezzati rappresentano un potenziale pericolo.
- Piccoli alberi, cespugli o recinzioni nelle vicinanze possono essere utili, funzionando come la resistenza al vento.

Preparazione del sito

Il sito deve essere preparato in modo che la base della casetta sia livellata tutt'intorno ed è necessario l'uso di una livella per il controllo.

La base può essere costruita con legno trattato o cemento, per impedire all'umidità di penetrare nella casetta. La casetta non è progettata per essere costruita direttamente sul prato. Inoltre, il terreno diventa fangoso durante i giorni di pioggia.

Se si fa una soletta di cemento, è importante che questa sia inclinata verso i bordi per evitare l'ingresso di acqua.

Prima di costruire la casetta, è necessario dare sufficiente tempo affinché il calcestruzzo o il cemento si asciugano.

Le basi possono anche essere costruite da mattoni, blocchi o montate su una piattaforma di cemento.

I mattoni o blocchi devono essere cementati su basi di cemento solide e livellati e il telaio della casetta forato e poi avvitato alla base.

NOTE IMPORTANTI:

- Trovare qualcuno che ti aiuti: sarà molto più facile con qualcuno che ti tiene le parti, passa gli attrezzi, ecc. Inoltre, alcuni passaggi richiedono due persone per sollevare le strutture insieme. Questo non è un lavoro molto pesante, quindi si adatta alla maggior parte delle persone abili.
- Dare sufficiente tempo: la fretta spesso causa errori e il rifare di assemblaggi errati. Se non hai mai costruito una casetta prima, dai abbastanza tempo di una giornata per completare con cura la costruzione.
- Tenere disponibili gli strumenti giusti a portata di mano.
- Indumenti di sicurezza come consigliati nella sezione 'Strumenti'.
- Disporre in ordine le parti e verificare che siano tutte presenti prima di iniziare la costruzione. Mettere su panni o fogli di plastica se c'è il rischio di graffiare le parti.
- Serrare tutti i dadi con attenzione, assicurandosi di non perderne nessuno. Verificare che il telaio sia quadrato e utilizzando una livella per controllare che sia in posizione verticale.

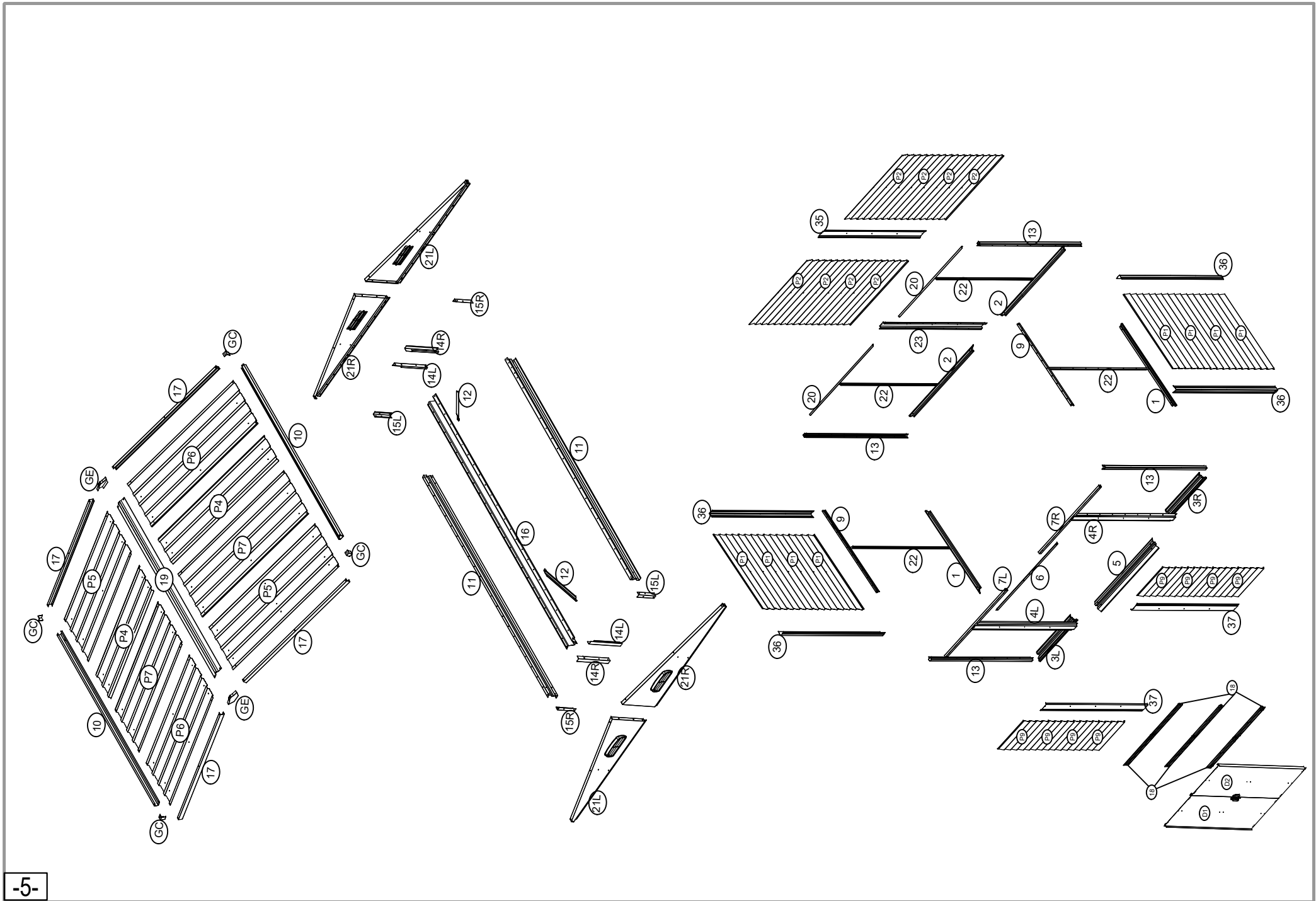

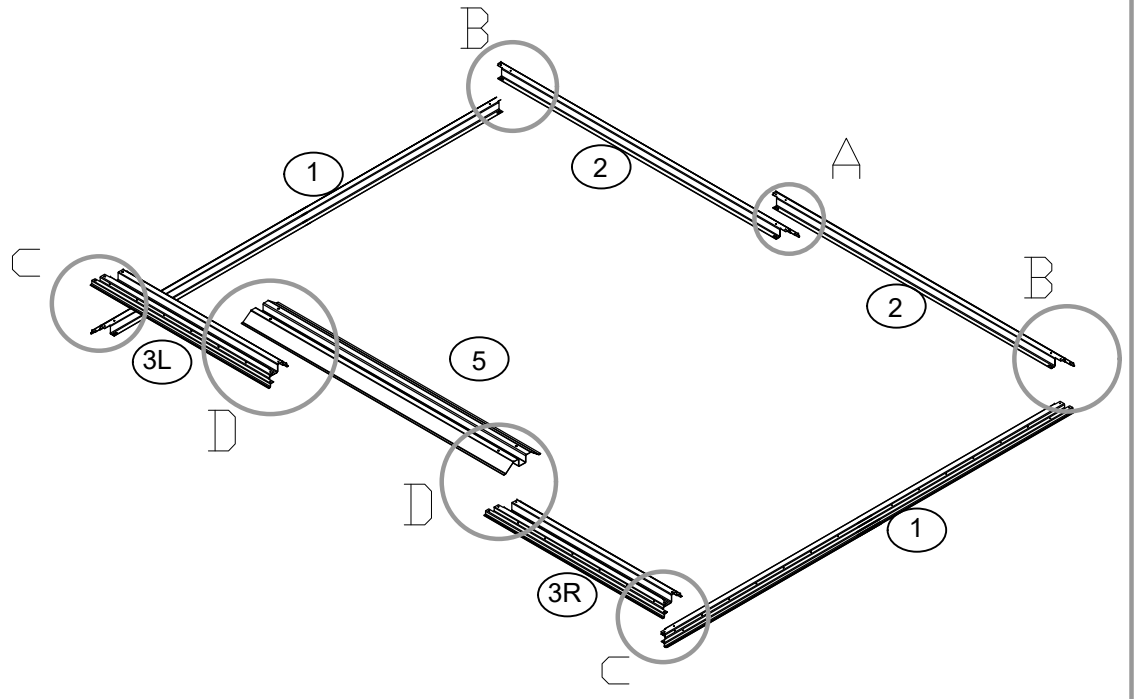
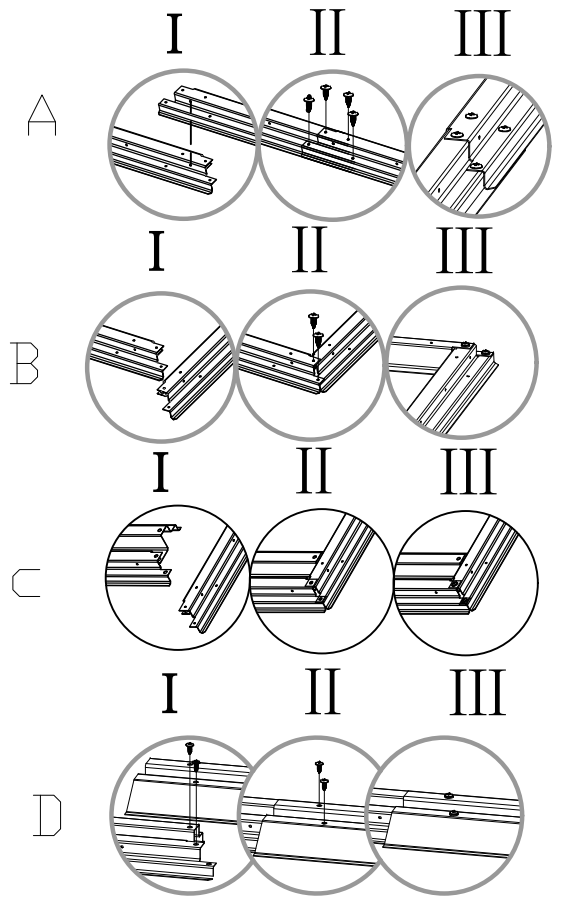
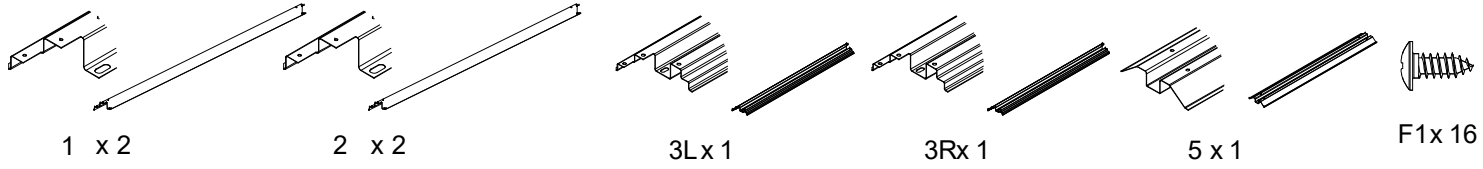

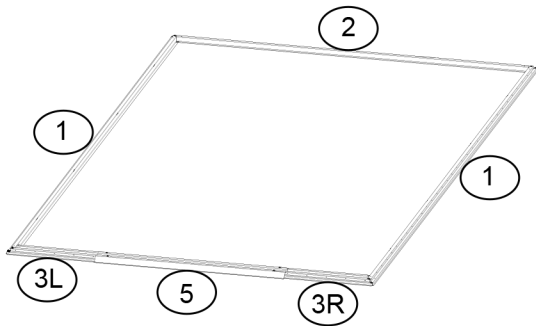

1. When diagonal measurements are equal, the frame is square.

1. Der Rahmen ist quadratisch wenn die diagonalen Messungen gleich sind.

1. Lorsque les mesures diagonales sont égales, le cadre est.

1. Quando le misure diagonali sono uguali, il telaio è quadrato.

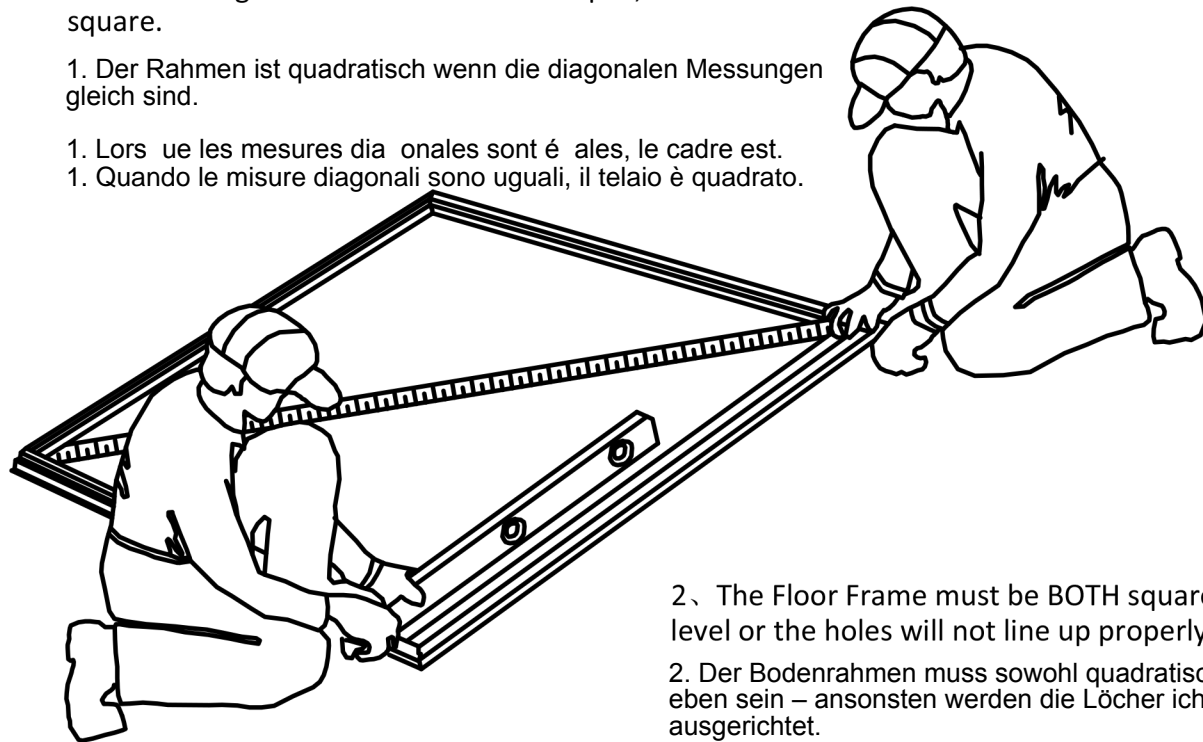

2. The Floor Frame must be BOTH square AND level or the holes will not line up properly.

2. Der Bodenrahmen muss sowohl quadratisch UND eben sein – ansonsten werden die Löcher nicht richtig ausgerichtet.

2. Le cadre de plancher doit être à la fois carré et de niveau ou les trous ne s'aligneront pas correctement.

2. Il telaio del pavimento deve essere SIA quadrato CHE livellato, altrimenti i fori non si allineeranno correttamente.

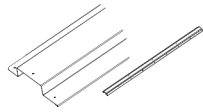

4R x 1



13 x 1



P9 x 1



P1 x 1

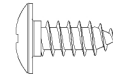

F1 x 7



S3 x 7

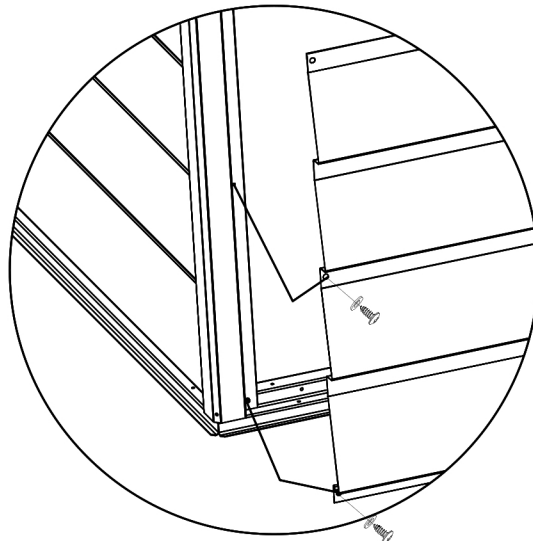
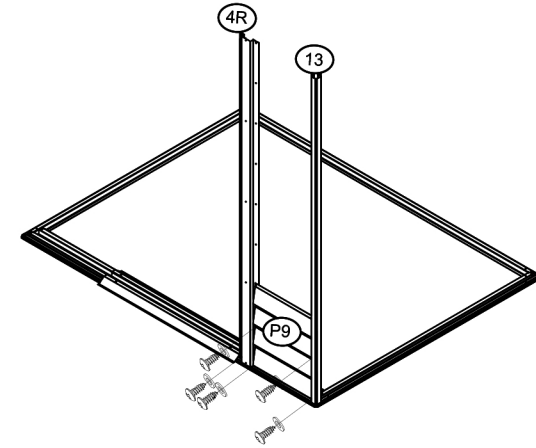
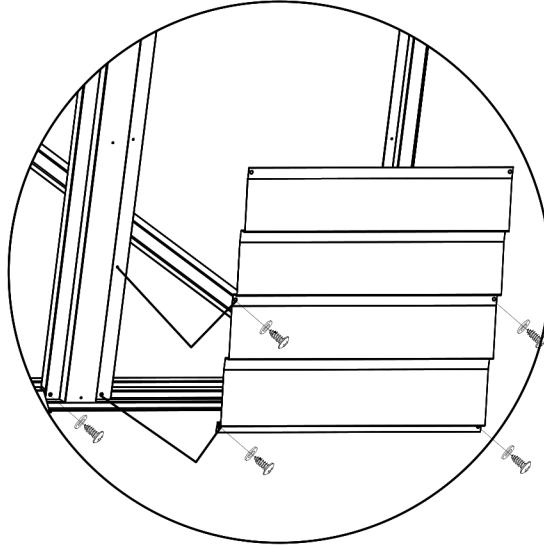
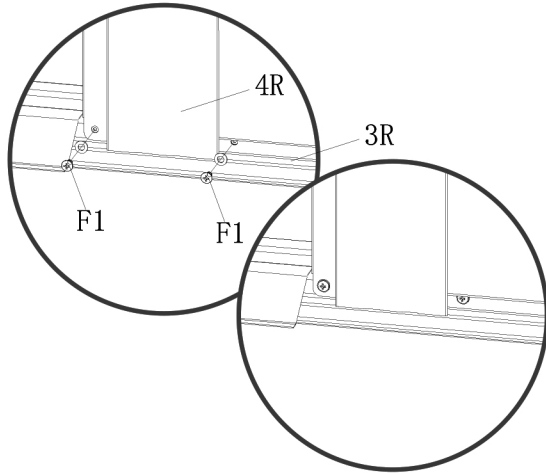

Attenzione all'inclinazione.
Richiede una persona o di uno scaffale da sostenere.

Pay attention to dumping
Need a person or a shelf to support.
Auf herunterfallene Teile achten
Brauchen Sie eine Person oder ein Regal
zu unterstützen.

Faites attention au dumping
Besoin d'une personne ou d'une étagère pour soutenir.

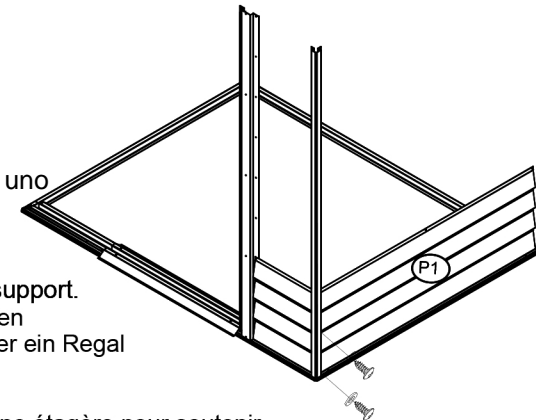



22x1



13x1

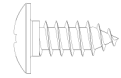

F1x 4



S3 x 4

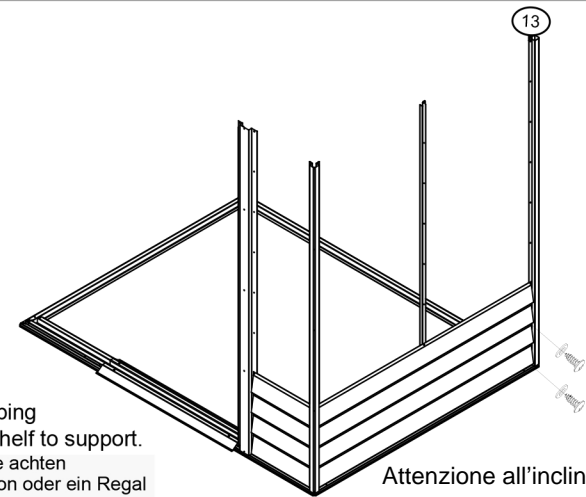
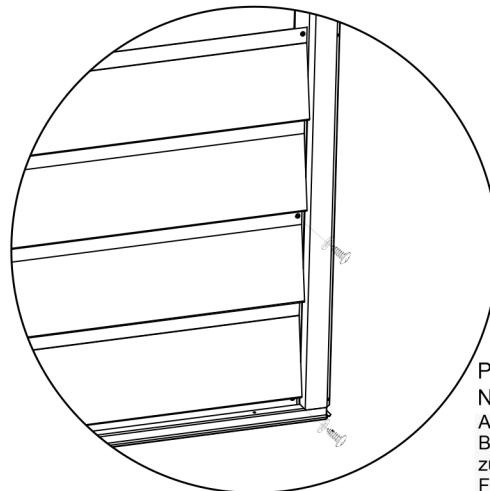
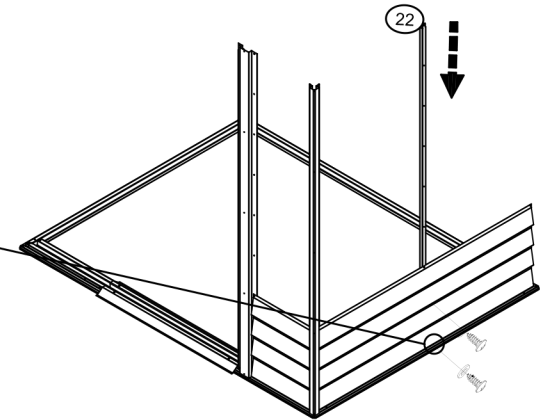
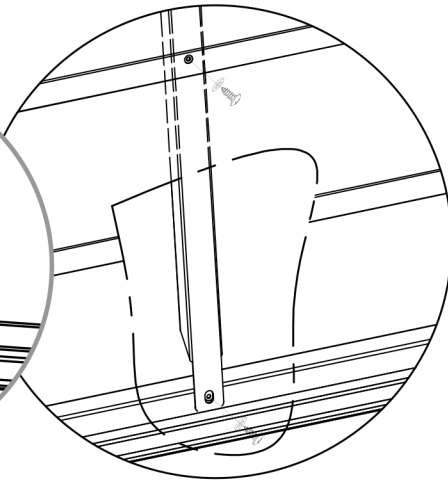
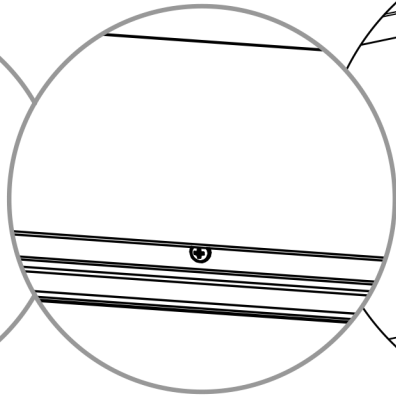
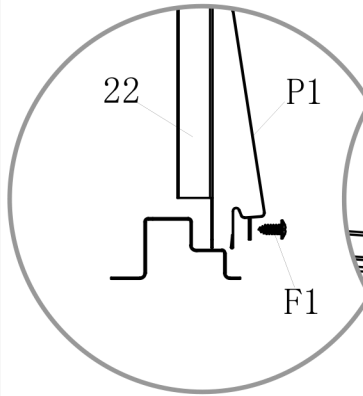

Pay attention to dumping
Need a person or a shelf to support.
Auf herunterfallene Teile achten
Brauchen Sie eine Person oder ein Regal
zu unterstützen.
Faites attention au dumping
Besoin d'une personne ou d'une étagère pour soutenir.

Attenzione all'inclinazione.
Richiede una persona o di uno
scaffale da sostenere.

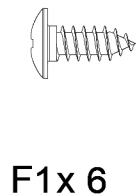
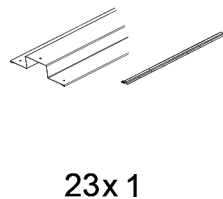
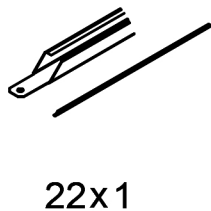
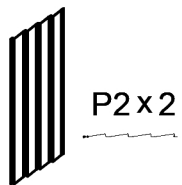

I

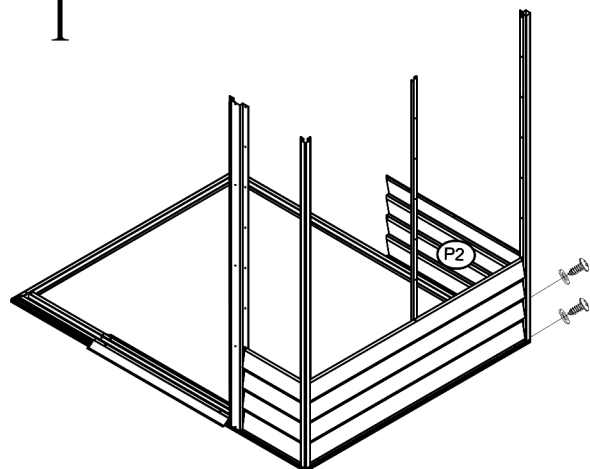

II

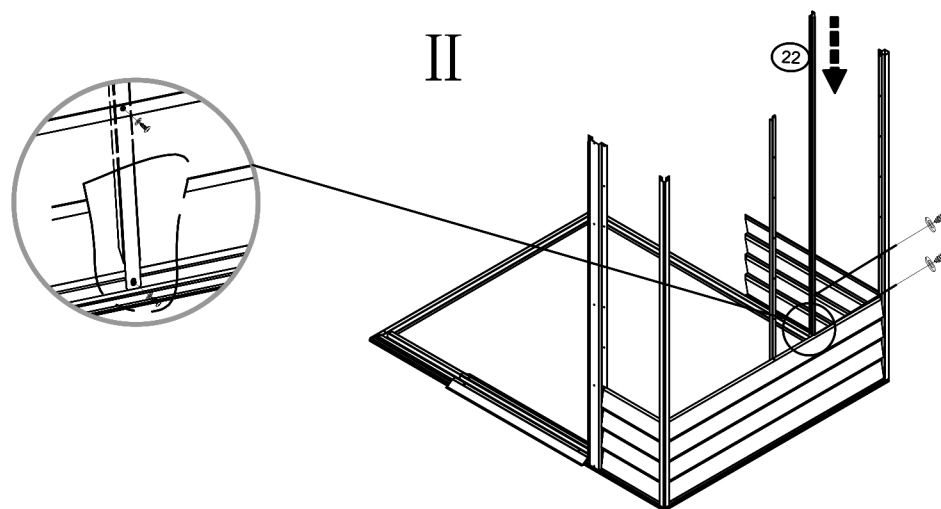

III

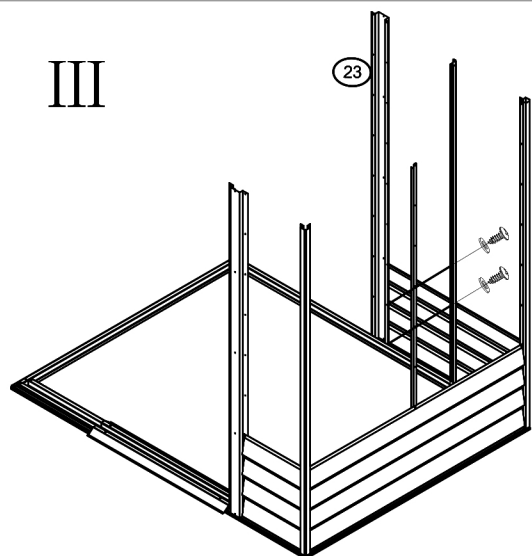

IV

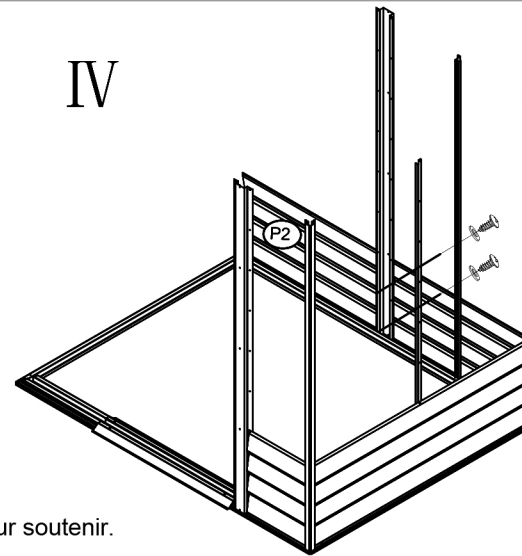

Attenzione all'inclinazione.
 Richiede una persona o di uno scaffale da sostenere.

Pay attention to dumping
 Need a person or a shelf to support.

Auf herunterfallene Teile achten
 Brauchen Sie eine Person oder ein Regal zu unterstützen.

Faites attention au dumping
 Besoin d'une personne ou d'une étagère pour soutenir.

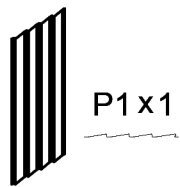

P1x1



13x1



22x2

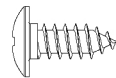

F1x8



S3x8

I

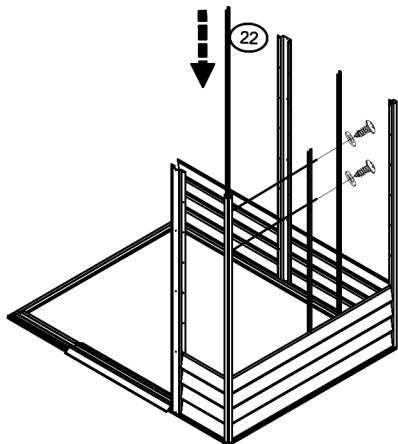

II

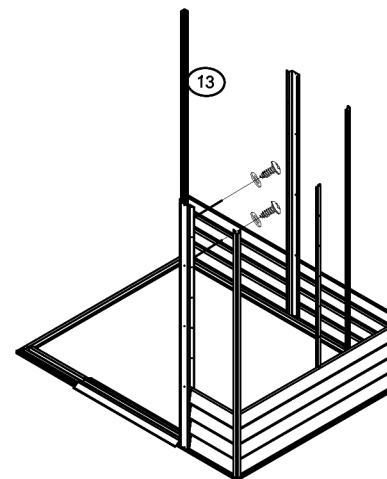

III

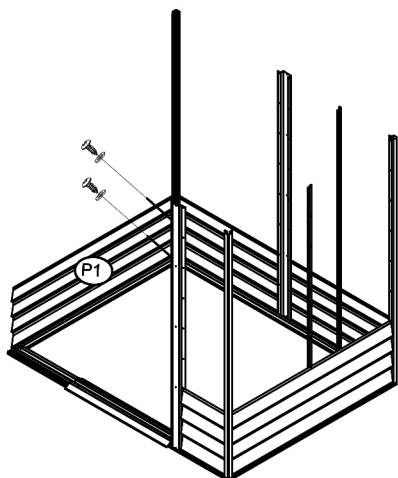

IV

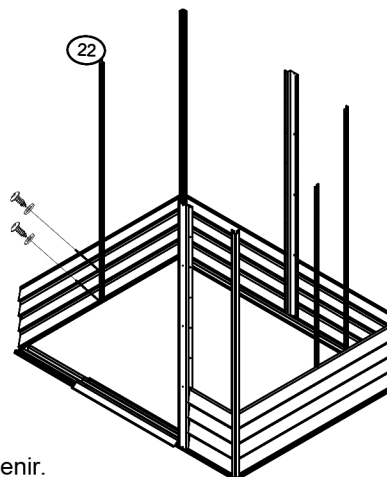

Attenzione all'inclinazione.
Richiede una persona o di uno scaffale da sostenere.

Pay attention to dumping
Need a person or a shelf to support.

Auf herunterfallene Teile achten
Brauchen Sie eine Person oder ein Regal
zu unterstützen.

Faites attention au dumping
Besoin d'une personne ou d'une étagère pour soutenir.

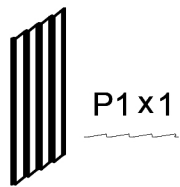

P1x1

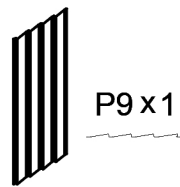

P9x1

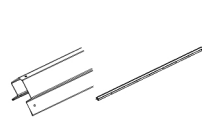

13x1

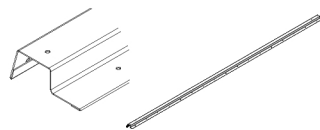

9x1

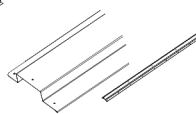

4Lx1

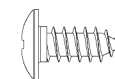

F1x 12



S3 x 12

I

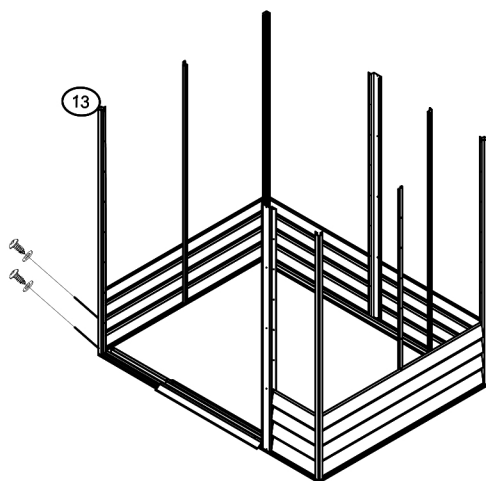

II

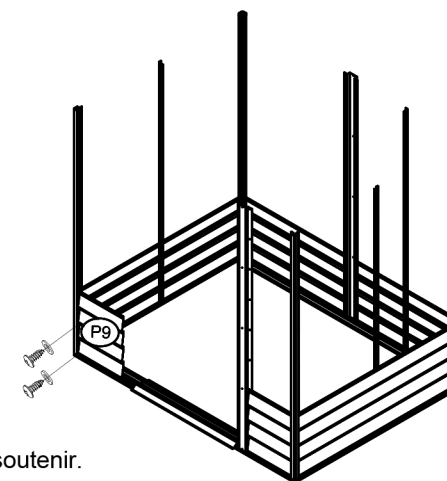

Attenzione all'inclinazione.
Richiede una persona o di uno scaffale da sostenere.

Pay attention to dumping
Need a person or a shelf to support.

Auf herunterfallene Teile achten
Brauchen Sie eine Person oder ein Regal zu unterstützen.

Faites attention au dumping
Besoin d'une personne ou d'une étagère pour soutenir.

III

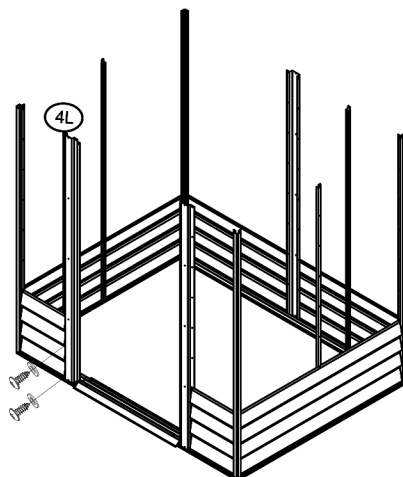

IV

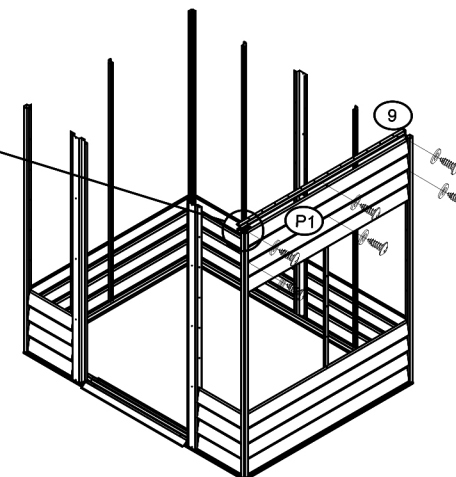
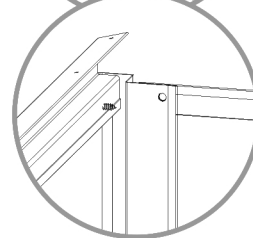
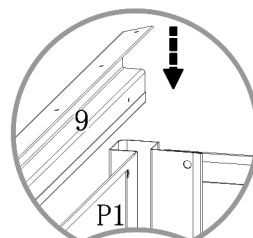

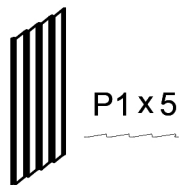

P1x5

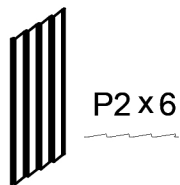

P2x6

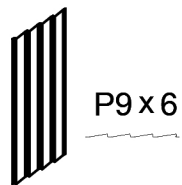

P9x6

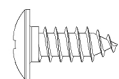

F1x 96



S3 x 96

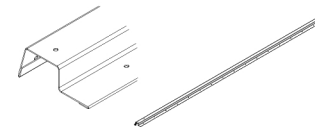

9x1

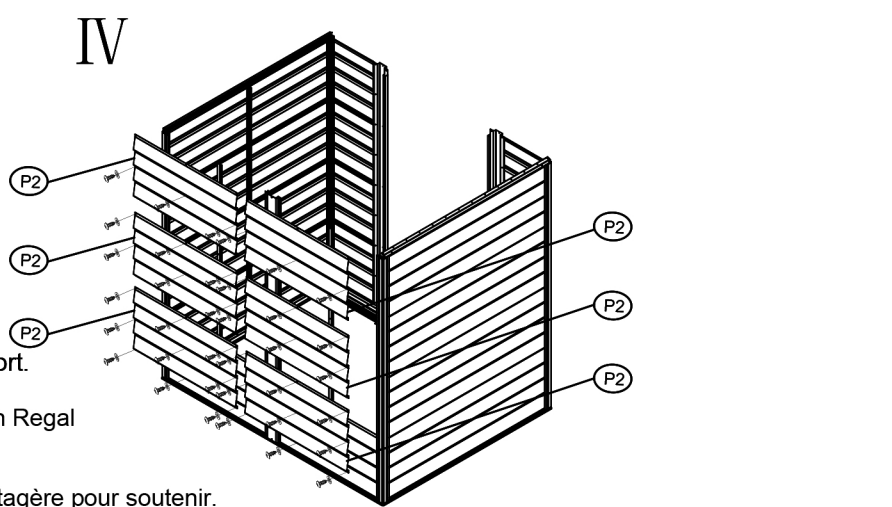
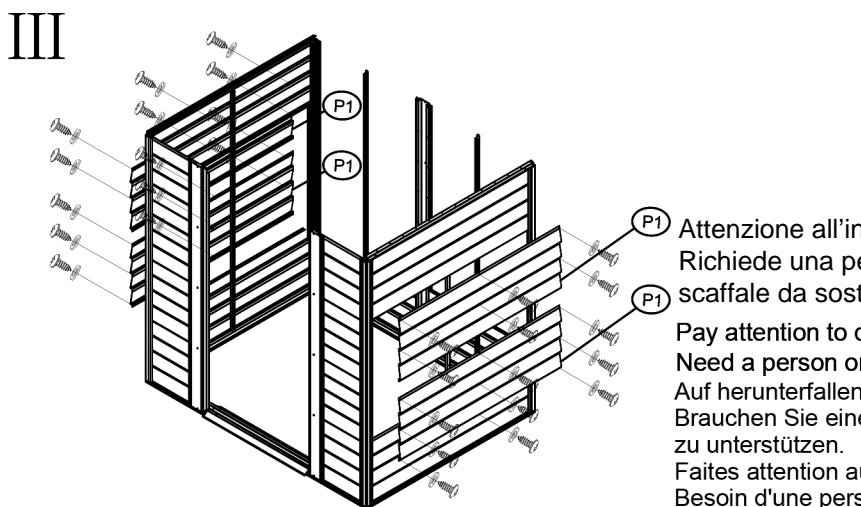
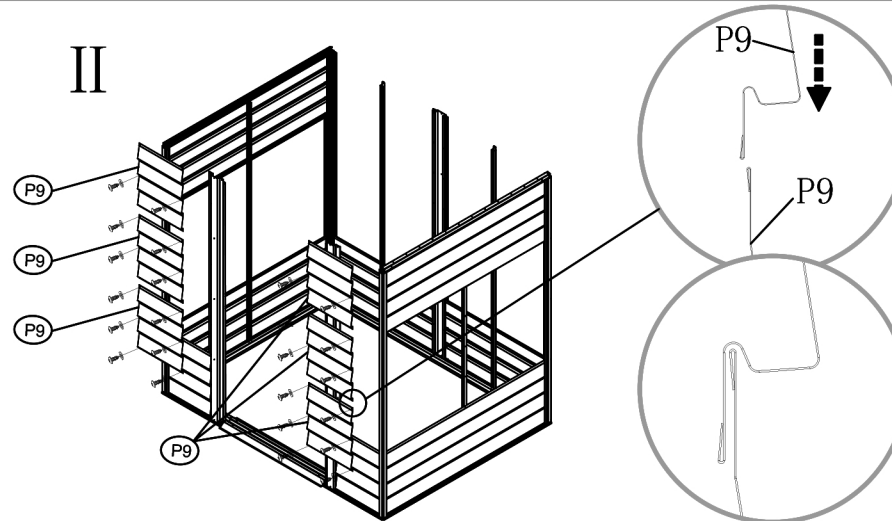
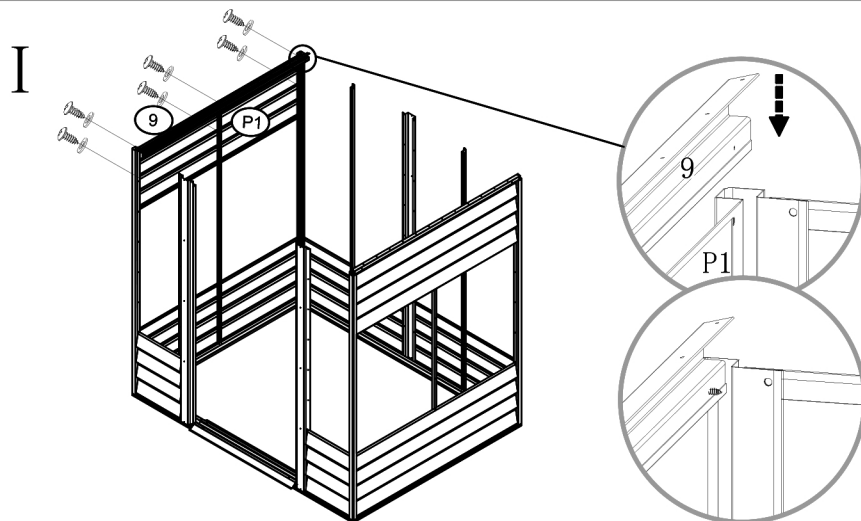

P1) **Attenzione all'inclinazione.**
 Richiede una persona o di uno scaffale da sostenere.
 Pay attention to dumping
 Need a person or a shelf to support.
 Auf herunterfallene Teile achten
 Brauchen Sie eine Person oder ein Regal zu unterstützen.
 Faites attention au dumping
 Besoin d'une personne ou d'une étagère pour soutenir.

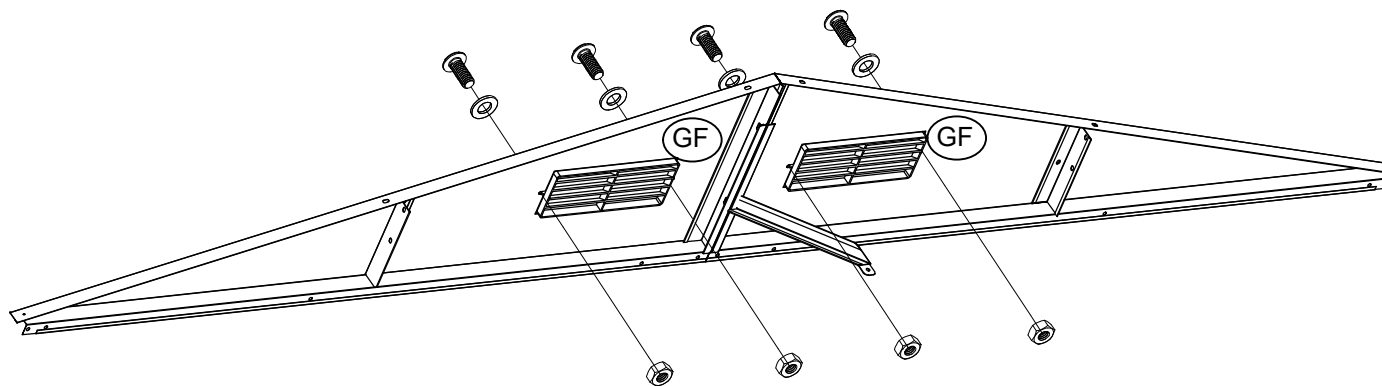
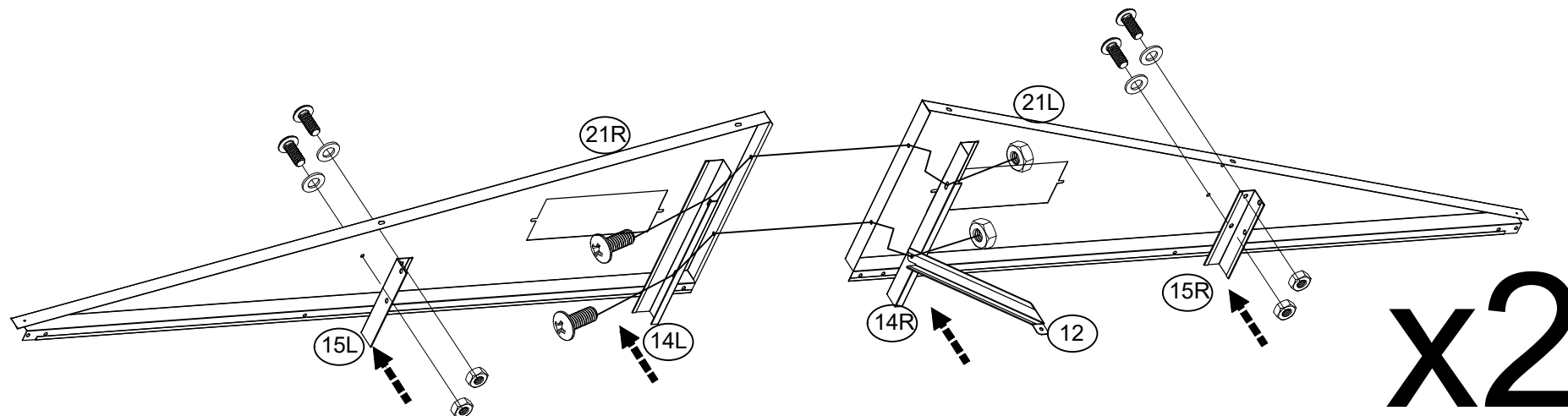
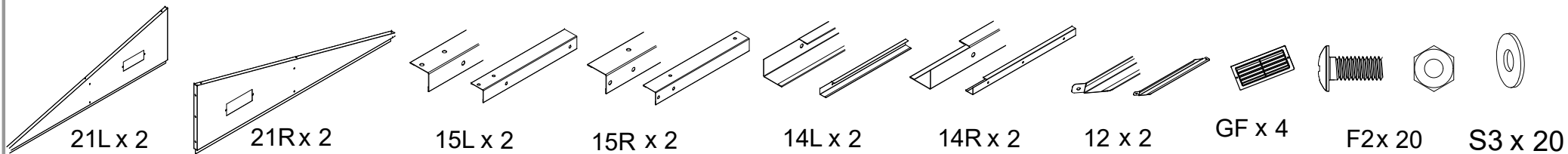

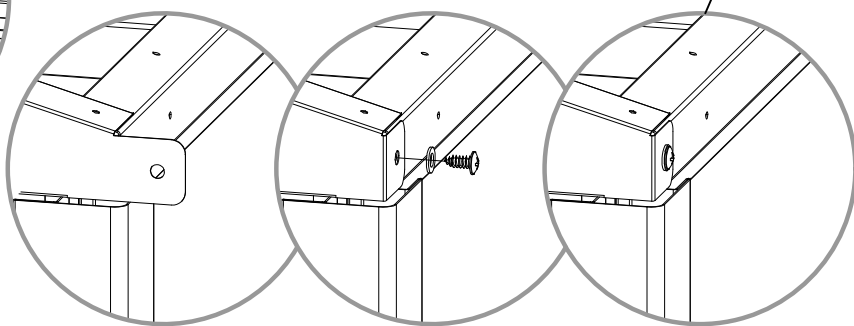
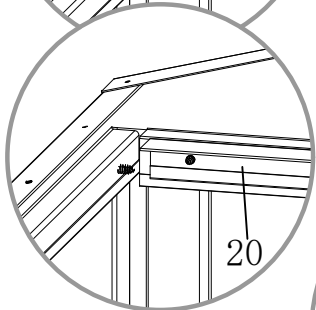
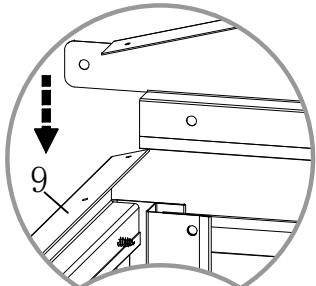
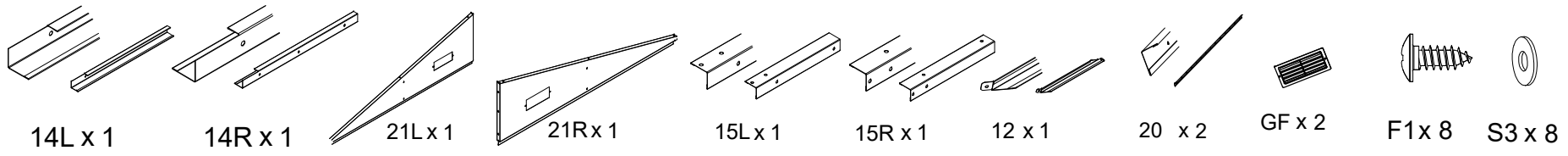

x2

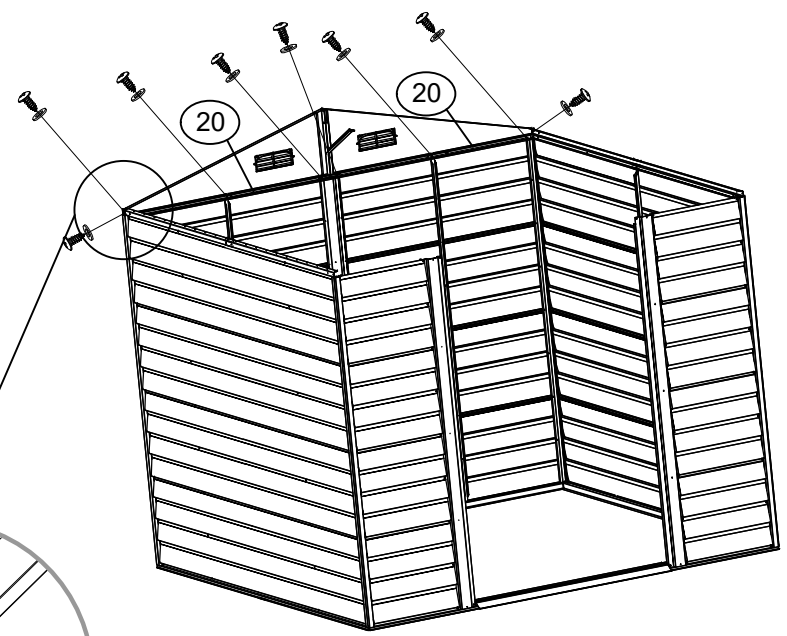

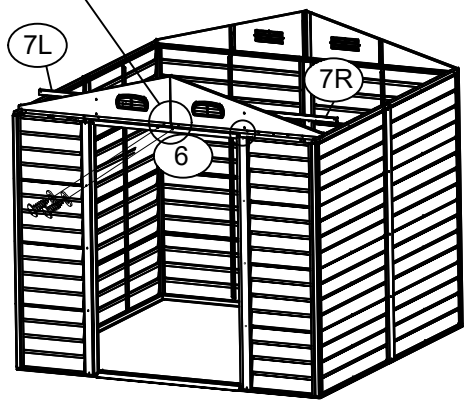
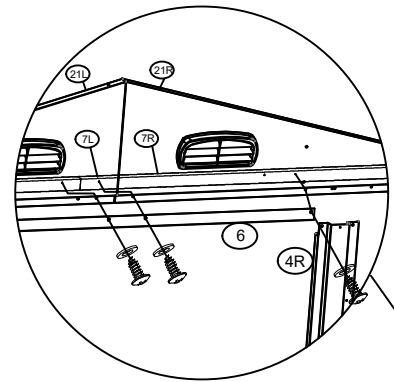
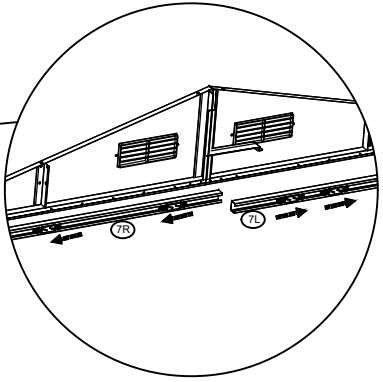
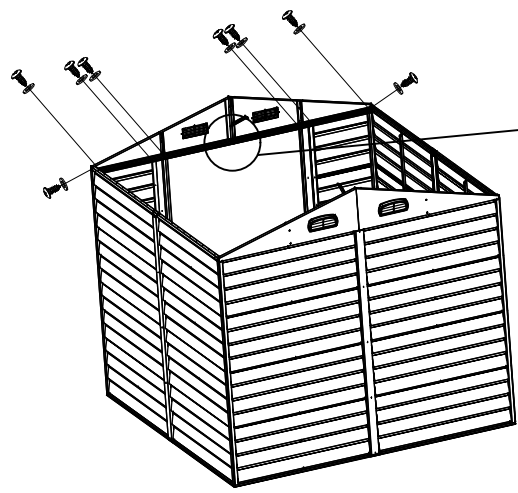
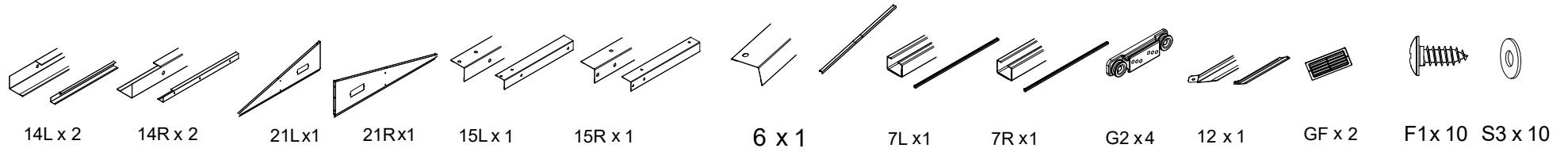

x2

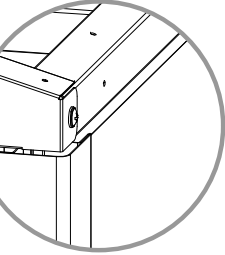
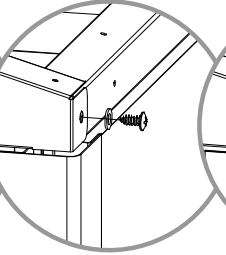
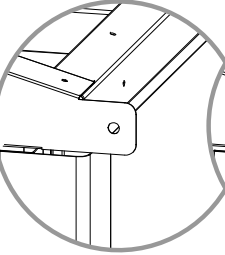
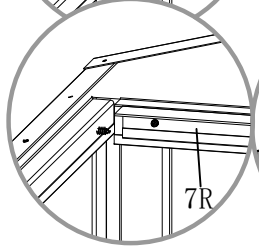
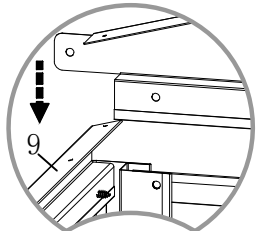

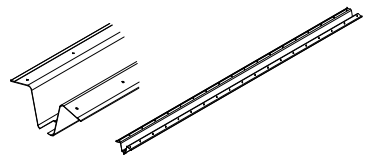

16 x 1

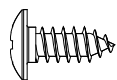

F1x 4



F2x 2

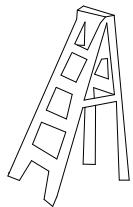
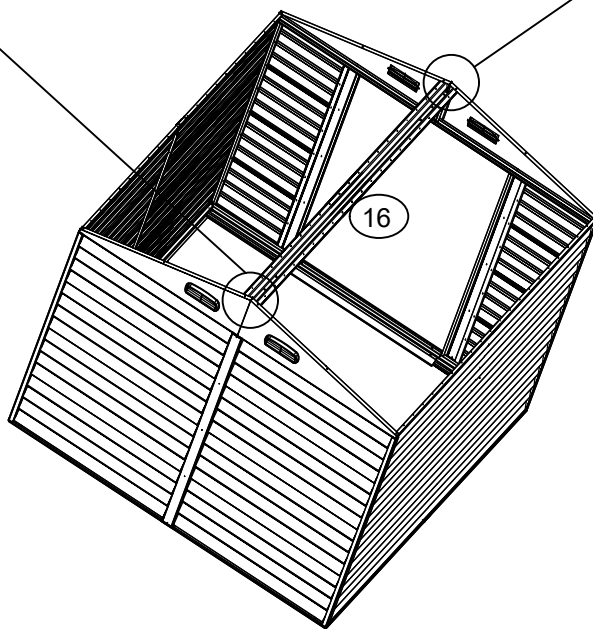
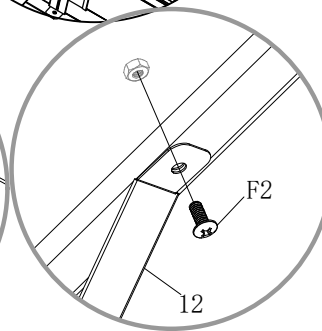
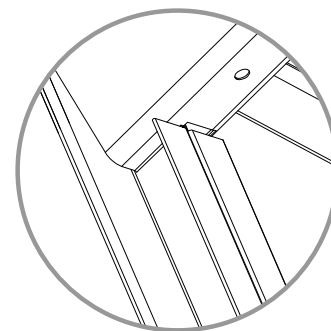
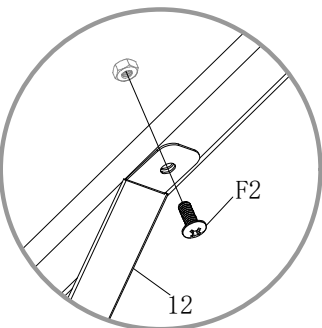
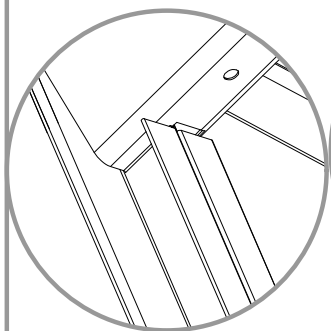
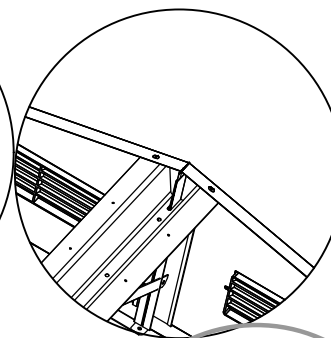
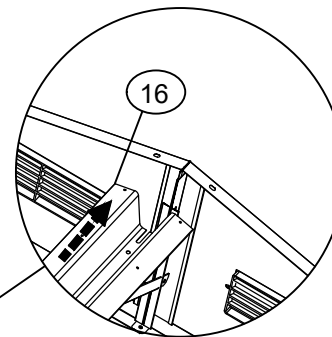
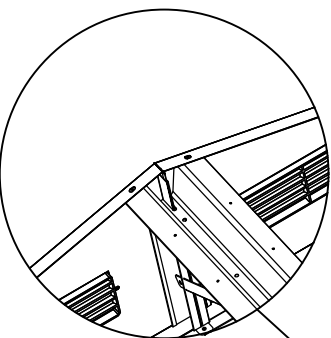
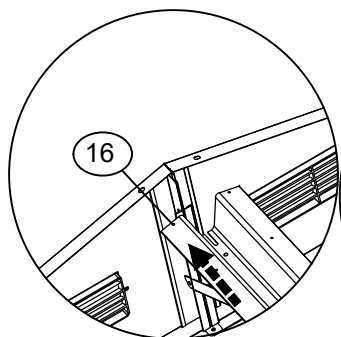

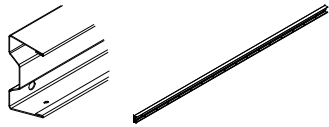

11 x 2

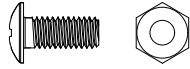

F2x 8

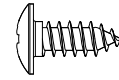

F1x 4

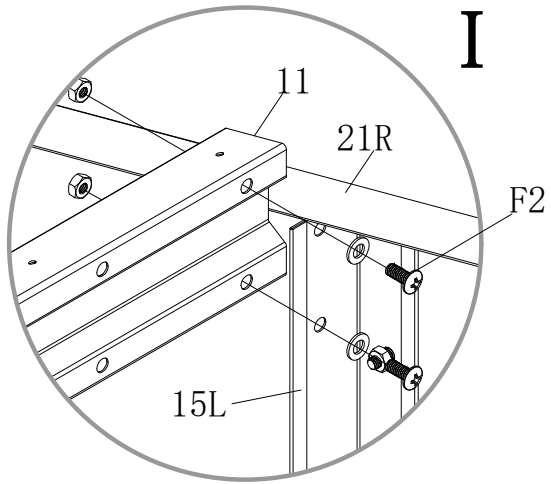

I

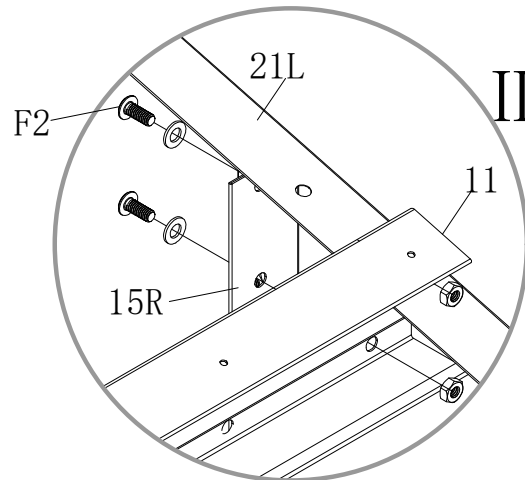

II

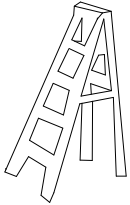
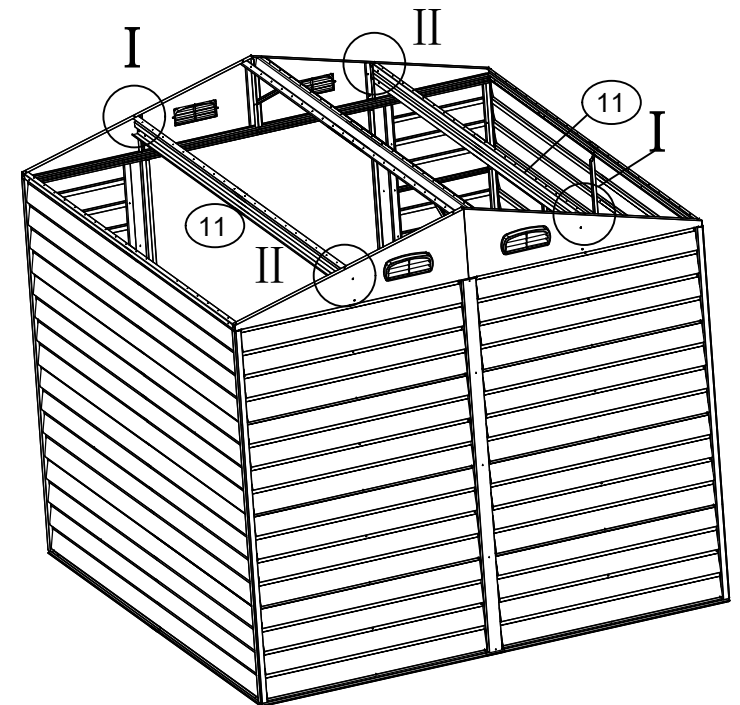

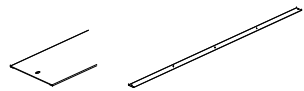

35x 1



36x 4



37x 2

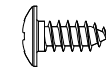

F1x 45



S3 x 45

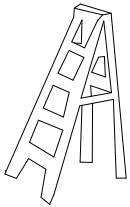
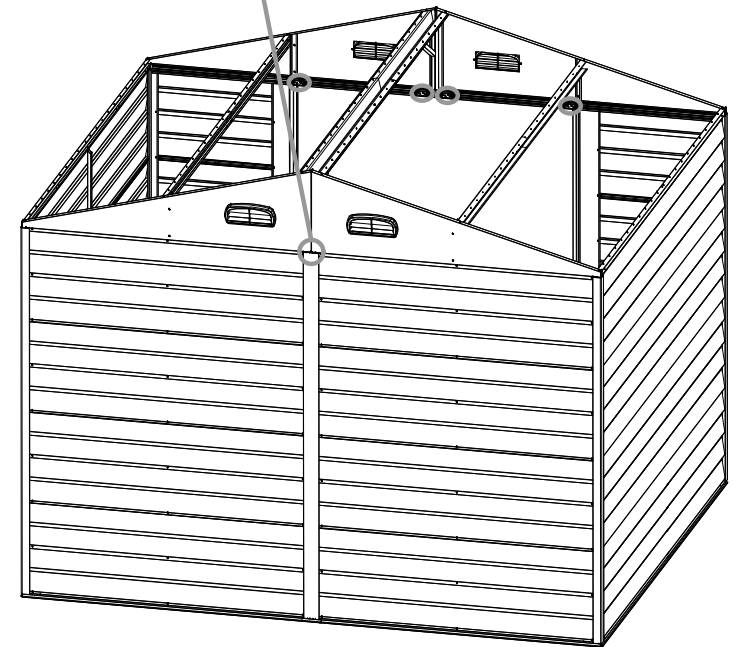
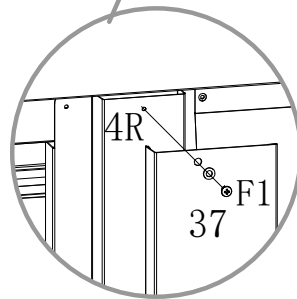
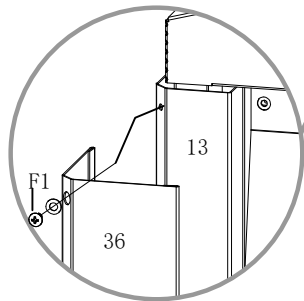
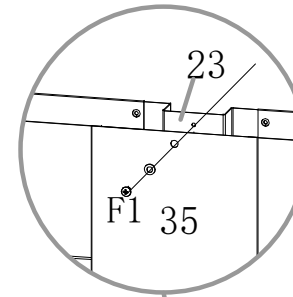
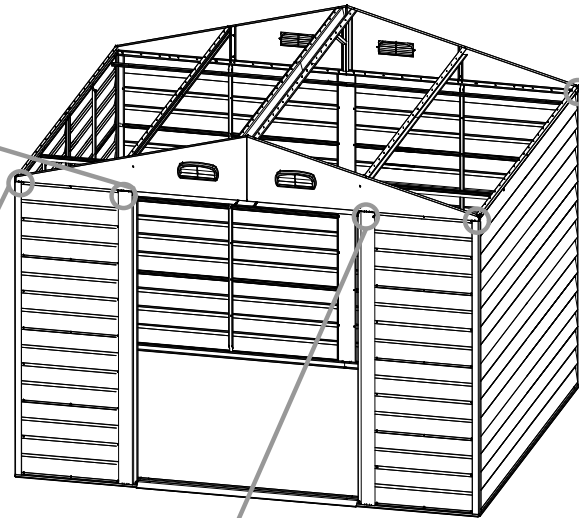
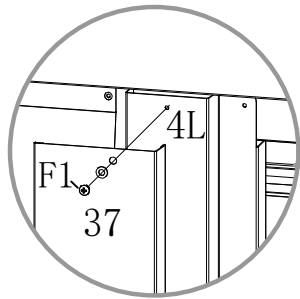

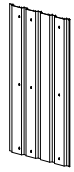

P4 x 2

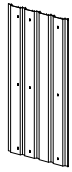
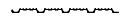

P5 x 2

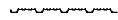

P6 x 2

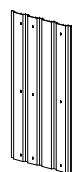
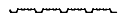

P7 x 2

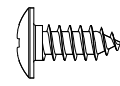

F1x 60



S3 x 60

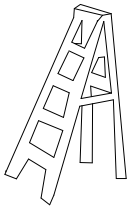
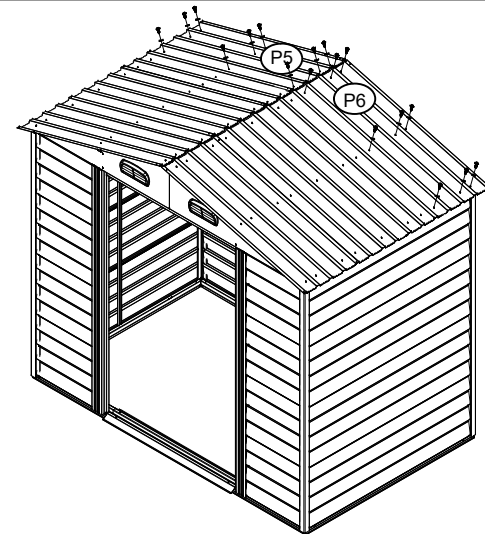
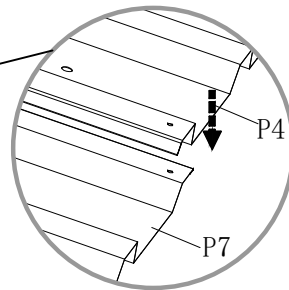
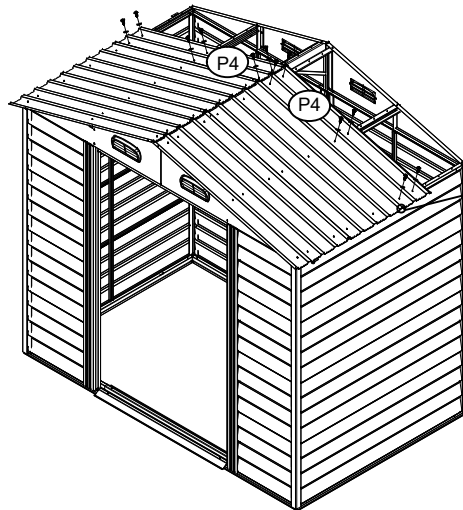
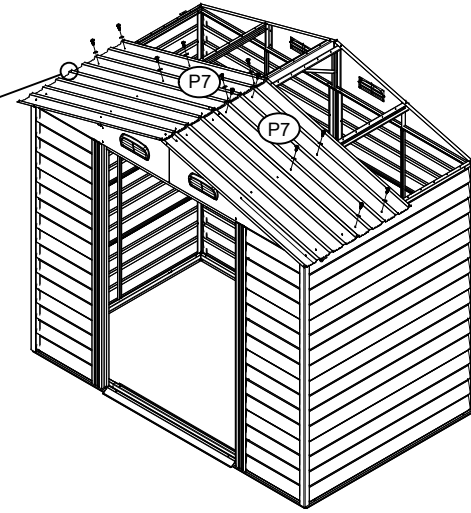
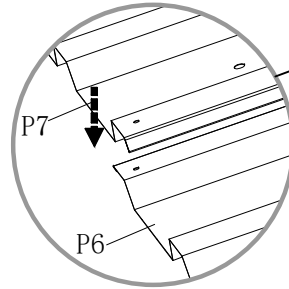
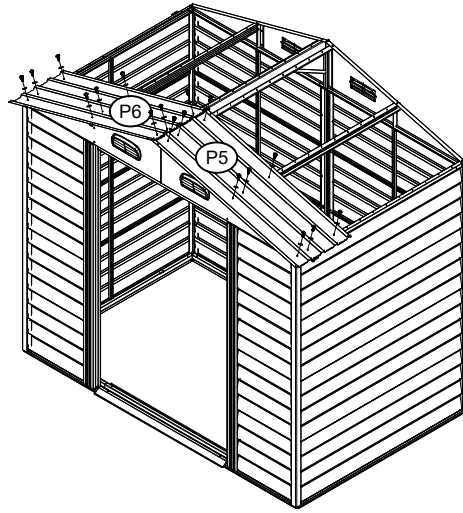

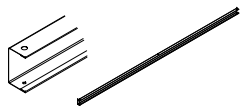

17 x 4

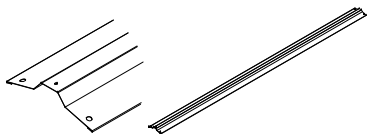

19 x 1

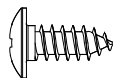

F1 x 6



S3 x 4

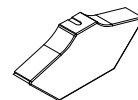

GE x 2

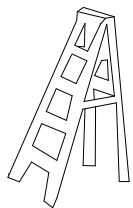
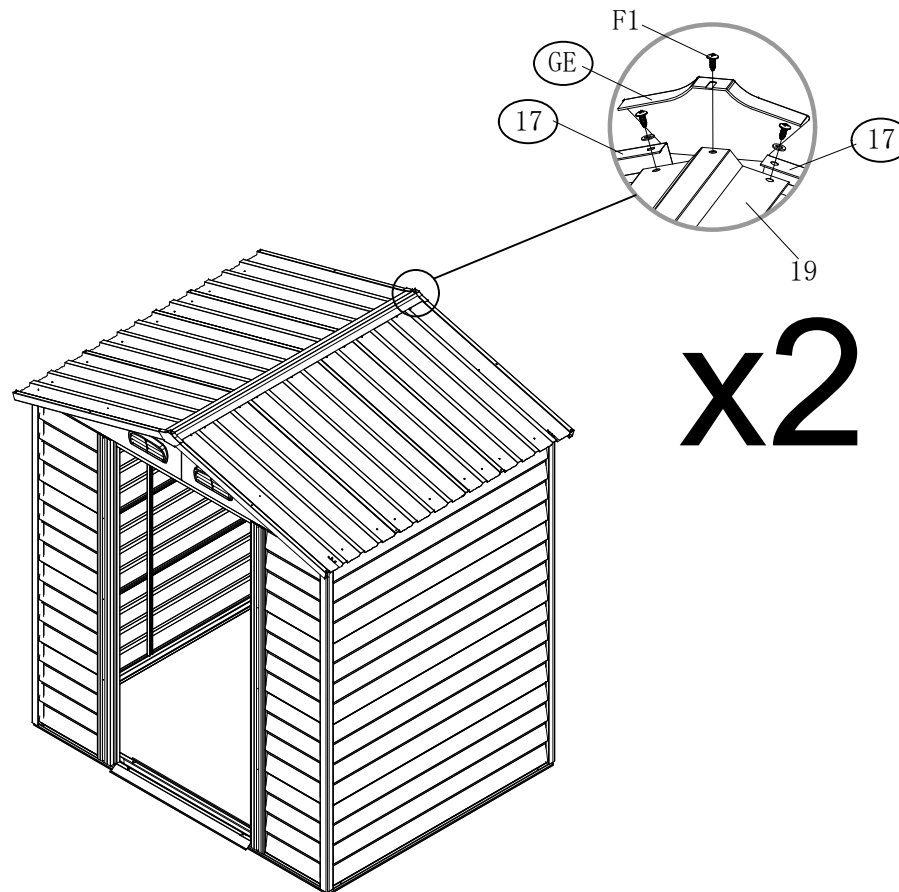
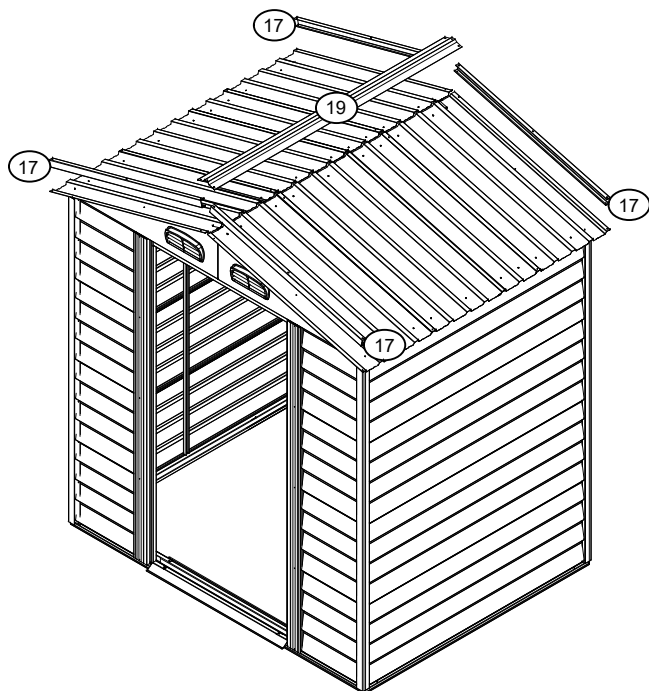



10x2

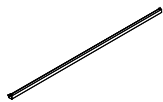

GCx4



GSx4



F1x12 S3x8

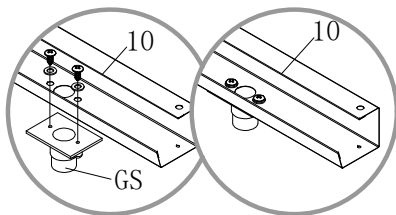
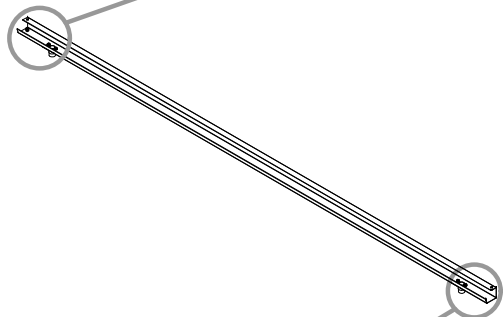
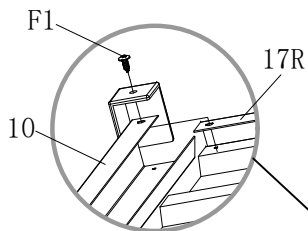
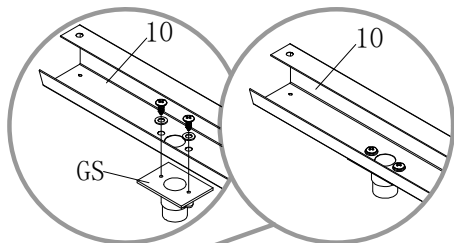

x2

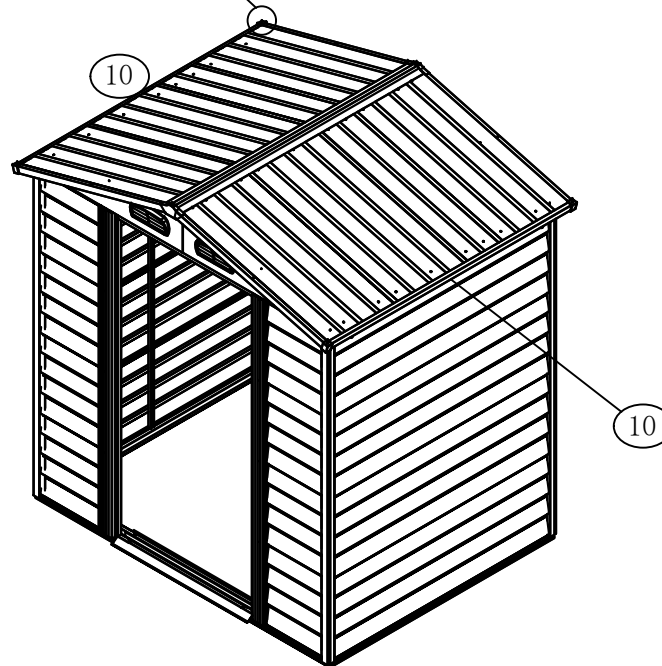



D1&D2 x1 18 x 6

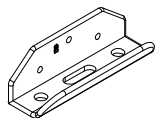
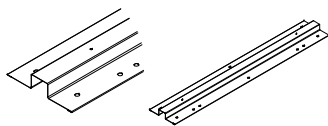

GB x 2

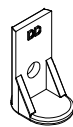

GD x 4



F1 x 12



F2 x 22

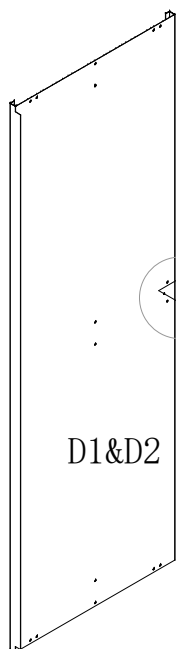

D1&D2

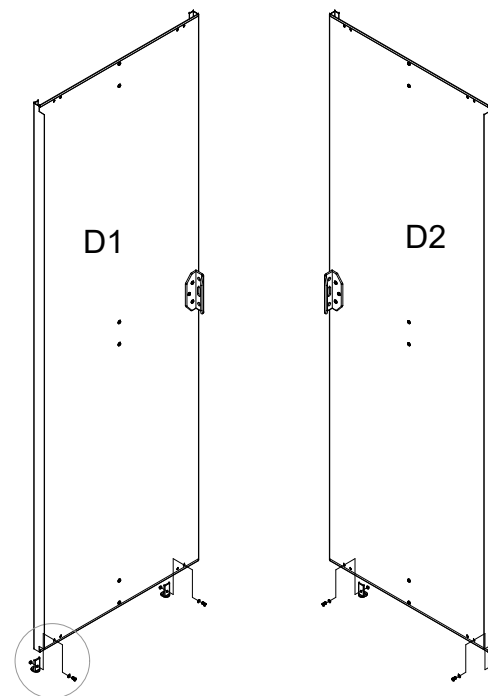
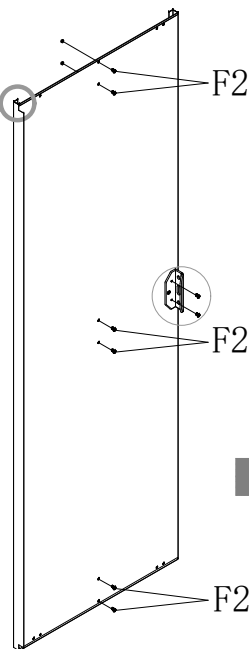
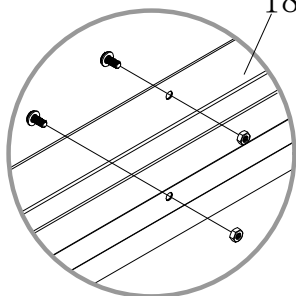
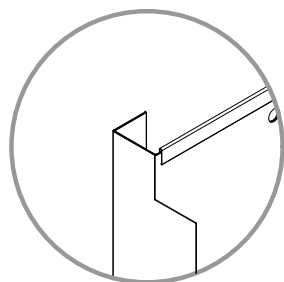
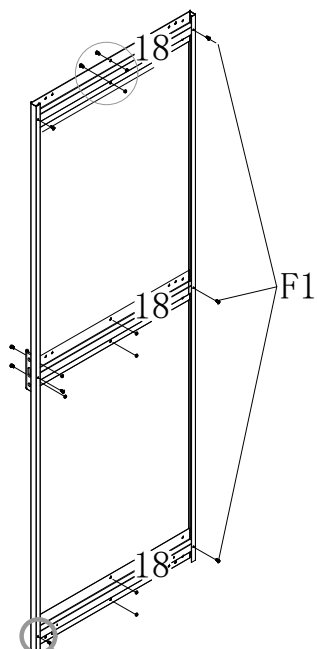

D1

D2

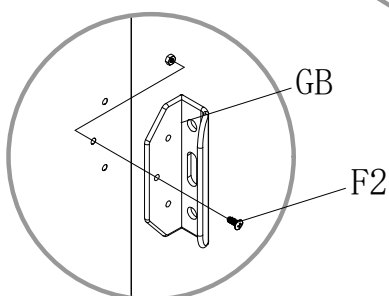

GB

F2

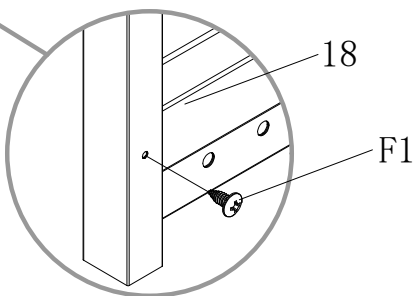

18

F1

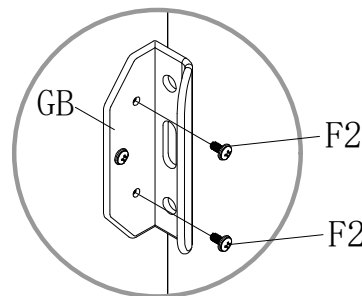

GB

F2

F2

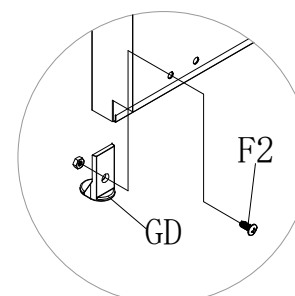

GD

F2

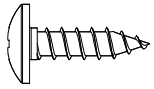

F3x 8

