

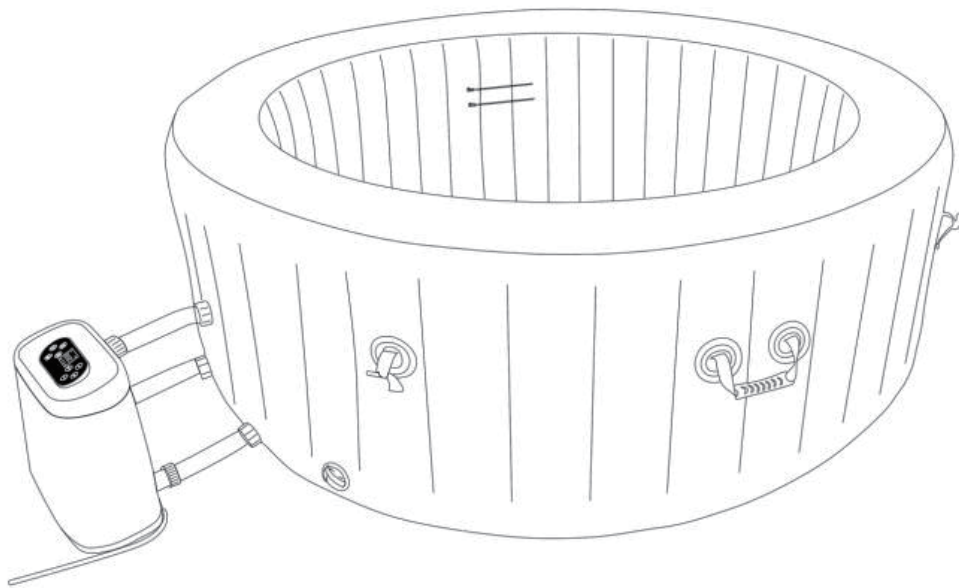

INbhc039_UK

848-046V72_848-046V71

Inflatable Spa Assembly Guide



IMPORTANT, RETAIN FOR FUTURE REFERENCE: READ CAREFULLY

ASSEMBLY & INSTRUCTION MANUAL

INTRODUCTION

Thank you for purchasing this Inflatable Hot Tub!

To ensure your personal safety during installation and to get the most out of your investment, please read this entire manual before beginning the installation process. If you feel that this process is too difficult to do on your own, we advise that you seek assistance from a local building or home improvement contractor.



WARNING:

Improper assembly and operation can result in severe personal injury as well as product failure not covered by warranty. Please follow all instructions carefully or contact technical support for assistance.

IMPORTANT SAFETY INSTRUCTIONS	3
1. Model and Specification	4
2. Configuration List	6
3. Installation	6
4. Operation of SPA Pump	10
5. SPA Maintenance	13
6. Simple troubleshooting	15

IMPORTANT SAFETY INSTRUCTIONS

- WARNING1:** The appliance should be supplied power through a GFCI-equipped outlet with a rated tripping current not exceeding 10 mA.
- WARNING2:** Electric installations should fulfill the requirements of local standards. Grounded appliances must be permanently connected to fixed wiring.
- WARNING3:** If the power supply cord is damaged, it must be replaced by the manufacturer or its service agent or a similarly qualified person in order to avoid a hazard. Replace damaged cord immediately.
- WARNING4:** Parts containing live current, except parts supplied with extra-low safety voltage not exceeding 12 V, must be inaccessible to a person in the bath.
- WARNING5:** To reduce the risk of electric shock, do not use an extension cord to connect unit to electric supply; provide a properly located receptacle.
- WARNING6:** Parts incorporating electrical components, except for remote control devices, must be located or fixed so that they cannot fall into the bath.
- WARNING7:** To avoid electric shock, do not use the spa when it is raining.
- WARNING8:** Never operate the spa if the suction fittings are broken or missing. Never replace a suction fitting with one rated less than the flow rate marked on the original suction fitting.
- WARNING9:** To reduce the risk of injury, do not permit children to use this product unless they are closely supervised at all times.
- WARNING10:** Water attracts children. Always have the spa locked with its cover on after each use.
- WARNING11:** When the jet function is going to be used, make sure the cover of spa is opened first.
- WARNING12:** Do not switch on if there is any possibility that the water in the spa is frozen.
- WARNING13:** Risk of electric shock. Never operate any electrical appliance when in the spa or when your body is wet. Never place any electric appliance, such as a light, telephone, radio, or television, within 5 feet (1.5m) of a spa.
- WARNING14:** Pets should be kept away from spa to avoid damage and injury.
- WARNING15:** Risk of electric shock. Install spa at least 5 feet (1.5m) from all metal surfaces. As an alternative, a Spa may be installed within 5 feet of metal surfaces if each metal surface is permanently connected by a minimum 8-gauge solid copper conductor to the wire connector on the terminal box that is provided for this purpose.
- WARNING16:** Risk of accidental drowning. Extreme caution must be exercised to prevent unauthorized access by children. To avoid accidents, ensure that children cannot use this spa unless they are supervised at all times.
- WARNING17:** During pregnancy, soaking in hot water may cause damage to the unborn fetus. Limit use to 10 minutes at a time while pregnant.
- WARNING18:** The use of alcohol, drugs, or medication before or during the spa use may lead to unconsciousness with the possibility of drowning.
- WARNING19:** Obese persons and persons with a history of heart disease, low or high blood pressure, circulatory system problems, or diabetes should consult a physician before they use a spa.
- WARNING20:** Persons using medication should consult a physician before using a spa since some medication may induce drowsiness while other medication may affect heart rate, blood pressure, and circulation. The water in a spa should never exceed 40°C (104°F). Water temperature between 38°C (100°F) and 40°C (104°F). Are considered safe for a healthy adult. Lower water temperatures are recommended for young children and when spa use exceeds 10 minutes. Since high water temperature has a high potential for causing fatal damage during the early months of pregnancy, pregnant or possibly pregnant women should limit spa water temperature to 38°C (100°F).
- WARNING21:** To reduce the risk of injury, never fill spa with water hotter than 40°C (104°F).
- WARNING22:** Hyperthermia occurs when the internal temperature of the body reaches a level several degrees above the normal body temperature of 98.6°F. The symptoms of hyperthermia include an increase in the internal temperature of the body, dizziness, lethargy, drowsiness, and fainting. The effects of hyperthermia include failure to perceive heat; failure to recognize the need to exit spa or hot tub; unawareness of impending hazard; fetal damage in pregnant women; physical inability to exit the spa or hot tub; and unconsciousness resulting in the danger of drowning. **WARNING** – The use of alcohol, drugs, or medication can greatly increase the risk of fatal hyperthermia.
- WARNING23:** Prolonged immersion in a spa may be injurious to your health.

- WARNING24:** Please use the safe sticker with SPA pool package together , and settle on the position where the users easy to see it beside the SPA pool. (except the European standard)
- CAUTION 1:** To avoid damage to the pump, the spa must never be operated unless the spa is filled with water.
- CAUTION 2:** Immediately leave spa if uncomfortable or sleepy.
- CAUTION 3:** Place only on surface that can withstand the floor loading requirement of your spa.
- CAUTION 4:** The spa should not be setup or left out in temperature lower than 4°C (40°F).
- CAUTION 5:** Never add water to chemicals. Always adding chemicals to water may result in a hazardous chemical spray.
- CAUTION 6:** In order to avoid a hazard due to inadvertent resetting of the thermal cutout, this appliance must not be supplied through an external switching device, such as a timer, or connected to a circuit that is regularly switched on and off by the utility.
- CAUTION 7:** THIS APPLIANCE CAN BE USED BY CHILDREN AGED FROM 8 YEARS AND ABOVE AND PERSONS WITH REDUCED PHYSICAL, SENSORY OR MENTAL CAPABILITIES OR LACK OF EXPERIENCE AND KNOWLEDGE IF THEY HAVE BEEN GIVEN SUPERVISION OR INSTRUCTION CONCERNING USE OF THE APPLIANCE IN A SAFE WAY AND UNDERSTAND THE HAZARDS INVOLVED. CHILDREN SHALL NOT PLAY WITH THE APPLIANCE. CLEANING AND USER MAINTENANCE SHALL NOT BE MADE BY CHILDREN WITHOUT SUPERVISION.
- CAUTION 8:** The spa should not be setup or left out in temperatures lower than 4°C (40°F).

Instructions

One.Model and Specification

Item No :ME20020EU/US		
Style	European regulations	U.S. Regulations
Capacity	2-4 Persons	2-4 Persons
Water capacity	650L(172gal)	650L(172gal)
Outer diameter	Φ165*68CM(Φ65"*26.7")	Φ165*68CM(Φ65"*26.7")
Inner diameter	Φ125*68CM(49.2"*26.7")	Φ125*68CM(49.2"*26.7")
Height	68CM(26.7")	68CM(26.7")
Bubble jets	92*2.5MM	92*2.5MM
Rated power	220 ~ 240V, 50Hz, 1540W	110~120V,60Hz,1385W
Heater power	1500W (Water temperatu 20°C)	1350W (Water temperatu 20°C)
Bubble jet power	650W	650W
Power cord length	5.5m	5.5m
Filter pumpspecifications	AC 12V/40W 1364L/300gal/H	AC 12V/35W 1364L/300gal/H
Pool cover	Φ130*20cm	Φ130*20cm

Item No :ME20022EU/US		
Style	European regulations	U.S. Regulations
Capacity	4 Persons	4 Persons
Water capacity	800L(211gal)	800L(211gal)
Outer diameter	Φ180*68CM(Φ71"*26.7")	Φ180*68CM(Φ71"*26.7")
Inner diameter	Φ140*68CM(55"*26.7")	Φ140*68CM(55"*26.7")
Height	68CM(26.7")	68CM(26.7")
Bubble jets	108*2.5mm	108*2.5mm
Rated power	220 ~ 240V, 50Hz, 1540W	110~120V,60Hz,1385W

Heater power	1500W (Water temperatu 20°C)	1350W (Water temperatu 20°C)
Bubble jet power	650W	650W
Power cord length	5.5m	5.5m
Filter pumpspecifications	AC 12V/40W 1364L/300gal/H	AC 12V/35W 1364L/300gal/H
Pool cover	Φ142*20cm	Φ142*20cm

Item No :ME20023EU/US		
Style	European regulations	U.S. Regulations
Capacity	4-6 Persons	4-6Persons
Water capacity	950L(250gal)	950L(250gal)
Outer diameter	Φ195*68CM(Φ76.7"*26.7")	Φ195*68CM(Φ76.7"*26.7")
Inner diameter	Φ155*68CM(61"*26.7")	Φ155*68CM(61"*26.7")
Height	68CM(26.7")	68CM(26.7")
Bubble jets	120*2.5mm	120*2.5mm
Rated power	220 ~ 240V, 50Hz, 1540W	110~120V,60Hz,1385W
Heater power	1500W (Water temperatu 20°C)	1350W (Water temperatu 20°C)
Bubble jet power	650W	650W
Power cord length	5.5m	5.5m
Filter pumpspecifications	AC 12V/40W 1364L/300gal/H	AC 12V/35W 1364L/300gal/H
Pool cover	Φ157*20cm	Φ157*20cm

SKU : ME20024EU/US		
Style	European regulations	U.S. Regulations
Capacity	4-6 Persons	4-6 Persons
Water capacity	930L(245gal)	930L(245gal)
Outer diameter	Φ180*68CM(Φ71"*26.7")	Φ180*68CM(Φ71"*26.7")
Inner diameter	Φ140*68CM(55"*26.7")	Φ140*68CM(55"*26.7")
Height	68CM(26.7")	68CM(26.7")
Bubble jets	108*2.5mm	108*2.5mm
Rated power	220 ~ 240V, 50Hz, 1540W	110~120V,60Hz,1385W
Heater power	1500W (Water temperatu 20°C)	1350W (Water temperatu 20°C)
Bubble jet power	650W	650W
Power cord length	5.5m	5.5m
Filter pumpspecifications	AC 12V/40W 1364L/300gal/H	AC 12V/35W 1364L/300gal/H
Pool cover	142**142*20cm	142**142*20cm

Two. Configuration List

Note: Check all accessories included

A1: SPA pool	B1: Pump	C1: Pool cover	C2: Aufpumpbare PVC-Abdeckung (optional)
D1: Inflation tube	E1: Hose	F1: Filter Cartridge	G1: Valve wrench
H1: Plug lock	H2: Key	I1: Blocker	J1: Back water cover
K1: Hose	L1: Waterproof repair patch	M1: Instruction Manual	N1: Repair material

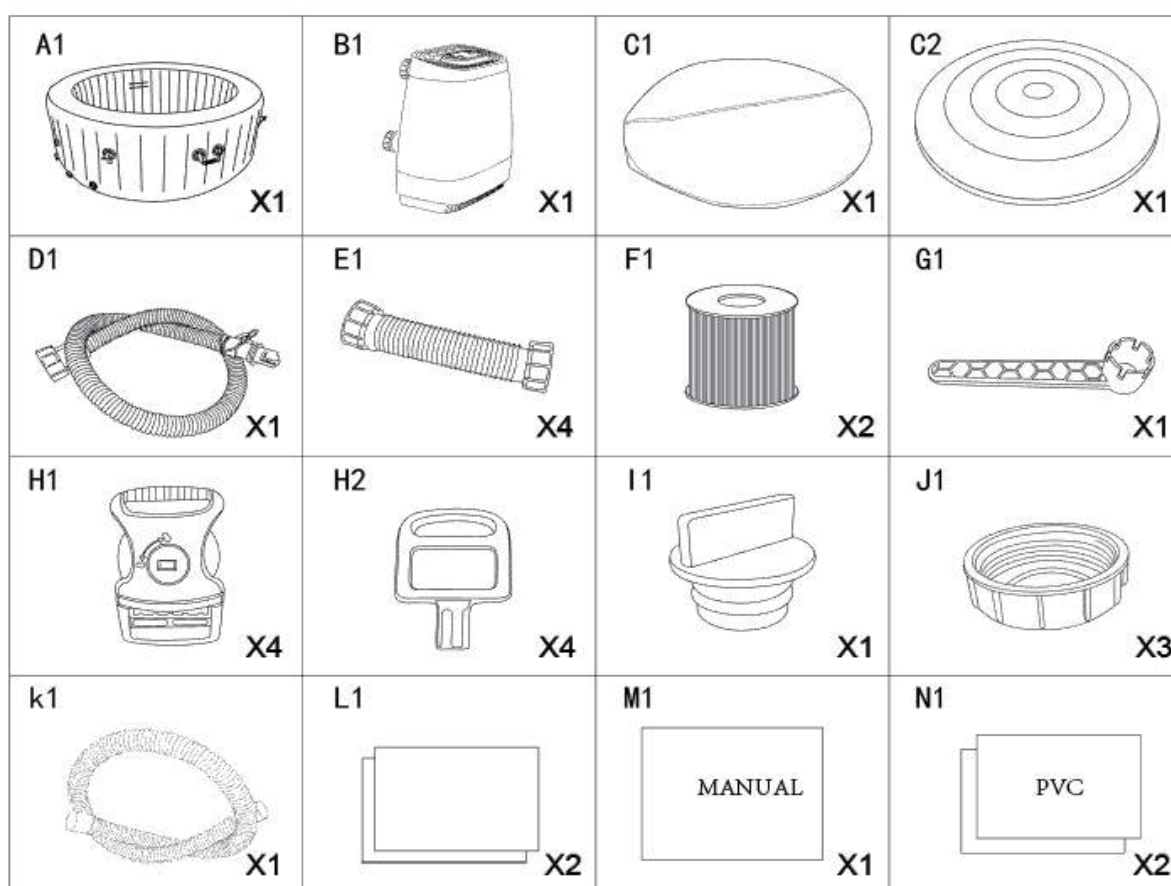

Three. Installation

3.1 Installation Site Requirements

Note: The ground should be able to bear the weight of the pool.

Note: There should be a water draining system around

Note: In order to prevent the danger of electric shock, please do not use the adaptor to connect the pump.
Important Tips

The ground shall be smooth and flat, and there shall be no sharp objects. The user should also consider the total weight of the user, SPA and water, and ensure that the ground in the use area has Sufficient strength to support it. There is a good drainage system beside the installation area. If the SPA is installed in a place that does not meet the safety requirements, any loss caused is not covered by the warranty because it is caused by improper use by consumers.

1) Indoor installation:

Some special requirements for indoor installation that need to be paid attention to:

©During the installation of the SPA, during the filling and draining water, water may spill on the ground. So floor drains and moisture-proof must be installed in this place.

©When SPA is used, it will bring a large amount of water vapor, and there should be no articles and appliances that are easy to be affected with damp in the use area. In order to ensure air quality and user comfort, it must be installed in a good ventilated environment.

Note: Do not install SPA on carpets or other items that are easy damaged by water.

2) Outdoor installation:

©The ground where spa pool is on must be flat and there are no sharp objects such as branches and stones nearby.

©Do not use in an environment with the temperature below 10 degrees Celsius (50 degrees Fahrenheit).

©It will affect the heating effect of SPA.

©Also do not expose SPA to the sun for a long time, which will shorten the service life of SPA.

©There should be a good drainage system near SPA pool, as SPA needs to drain.

3.2 SPA pool assembly

Warning: Please use SPA's matching pump to inflate the pool, and do not over inflate it. Please do not use other high-pressure air pumps for inflation. The normal working pressure of the pool is 5.0KPa/0.87psi. Excessive pressure will cause to burst or damage the joins of the pool.

a) Take the pool on the ground, connect the threaded end of the inflatable tube to the inlet with bubble mark on the pump (see figure 1&2) and inflate the SPA pool with another end of the inflatable tube. (see figure 3)

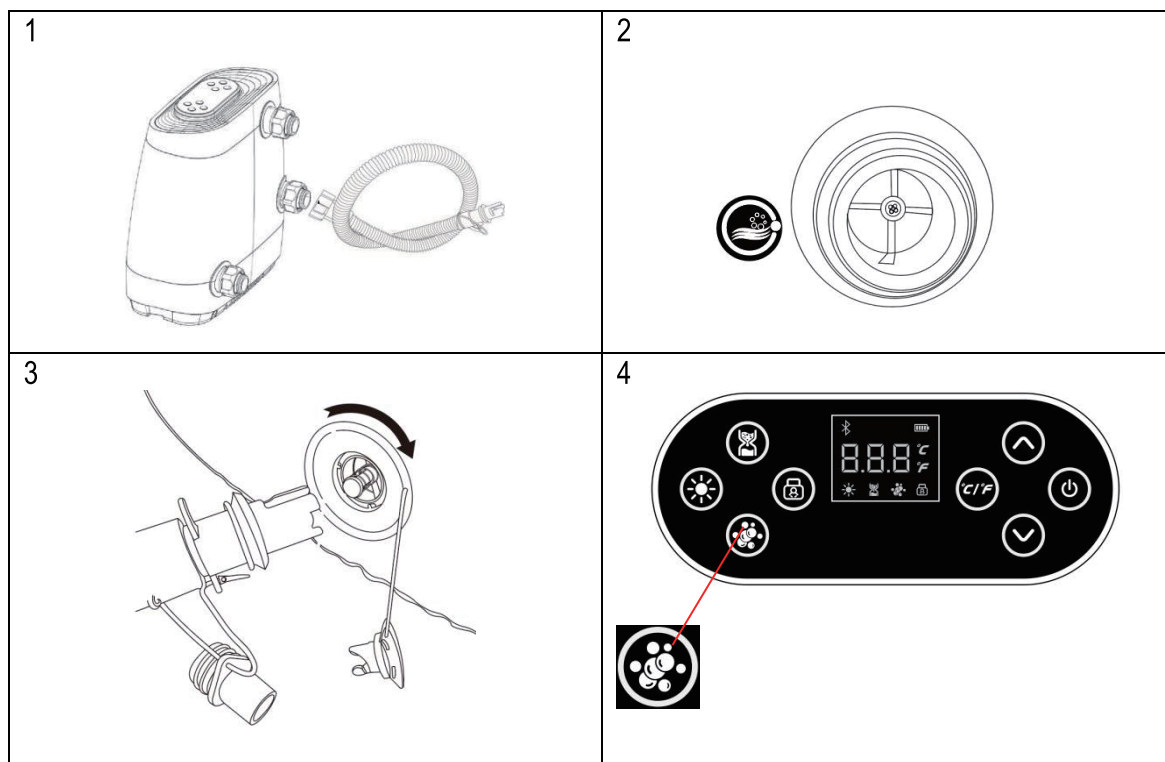

b) Connect the power plug of the SPA pump into the adapted power socket, press the bubble jet button to start inflating the SPA pool (see figure 4 above)

Please fill the air chamber on the side wall of the SPA pool first. If the inflatable top cover is provided, fill the top cover as well.

Tips:

1) How to use the safety valve.

- ⦿ Open the cap of valve;
- ⦿ Insert the inflatable hose into the inlet to inflate and insert the cap of the valve when the inflation is complete; see Figure 5
- ⦿ Deflation: open the cap of valve and let the air out slowly from the chamber.

2) How to use a rotated valve

- ⦿ Open the cap of valve; Press the red point on the up position.
- ⦿ Insert the inflatable hose into the air inlet and rotate it in place clockwise, and cover the cap when the inflation is complete; see Figure 6
- ⦿ Deflation: open the cap of valve, press the middle red point on the down position, let the air slowly out from the chamber.

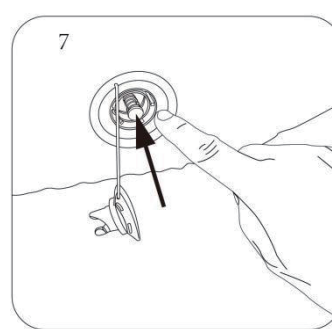
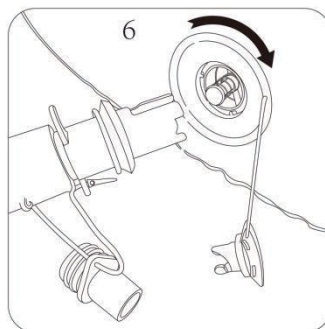
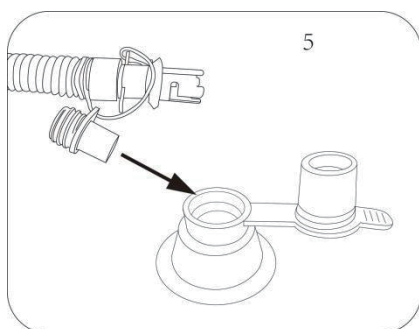

3.3 Use of lock sockets

Insert the key into the hole in the middle of the socket and open or lock it in the direction of the switch shown in figure 8

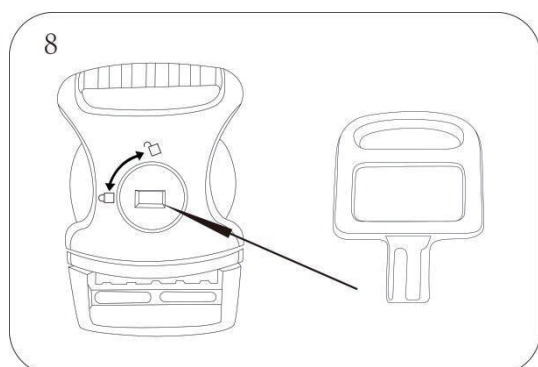

3.4 Connecting the pump to the pool

Note: The power plug must be pulled out before connecting the pump to the pool.

◎ Connect the pump and pool by pipes according to the marks on, see figure 9

◎ Assembling the filter cartridge

The filter cartridge is screwed to the water inlet wall of the pool and rotated clockwise. See figure 10

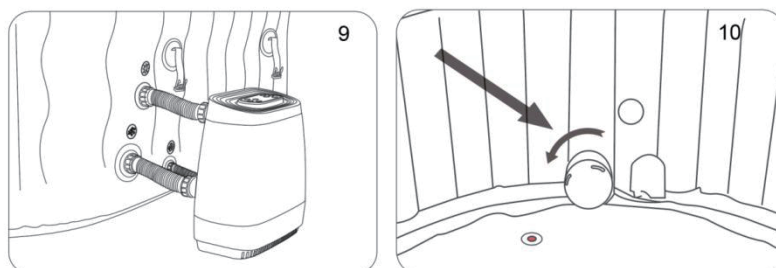

◎ Fill the pool with water

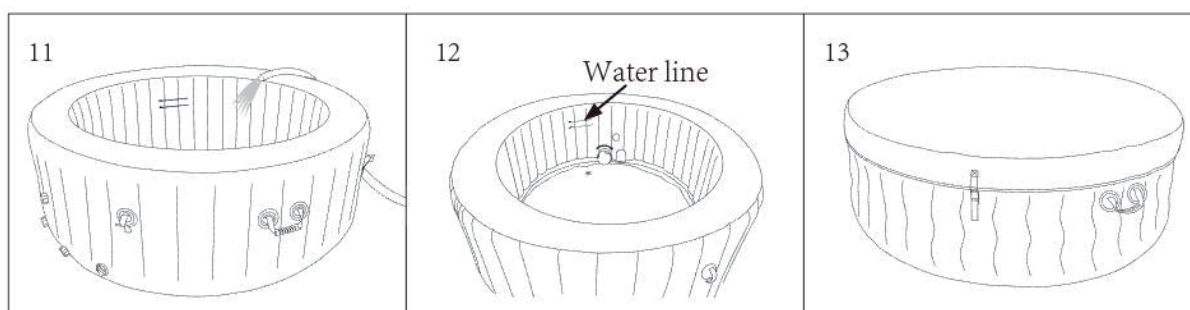

Fill the water with water hose until the water reaches the printed water level line on the inner wall of the pool. See figure 11, 12, 13

Warning:

- ◎ Do not plug in during filling the water. Take care of the water hose to prevent them from falling off to cause the water leakage.
- ◎ Please cover the pool well when you heat the water.
- ◎ Please make sure that the children use the pool under the supervision of adults.
- ◎ When not in use, please cover the pool and lock the buckle to prevent children from entering the pool.

3.5 Replacement pumps

Before replacing the pump, cover the inlet and outlet on the inner wall of the pool with a backwater cover to prevent the water from flowing out, as shown in figure 14

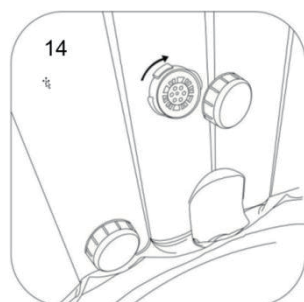

Four. Operation of SPA Pump

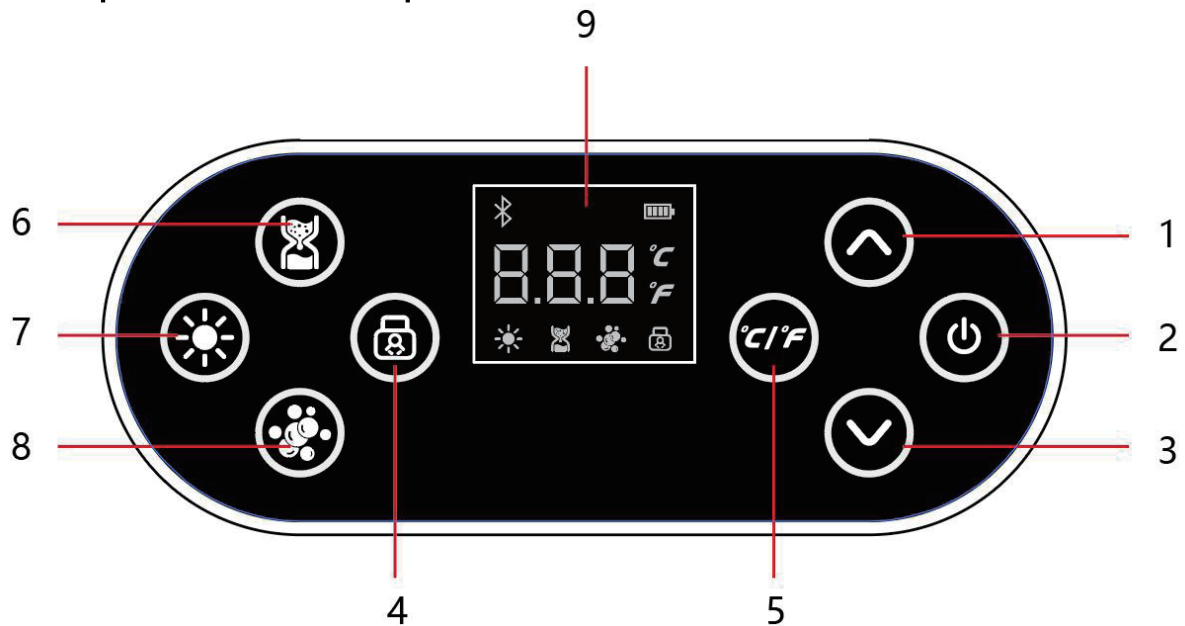

4.1 Control panel for SPA pumps

1、 Temperature up	2、 Power switch	3、 Temperature down	4、 Temperature modeswitching
5、 Child lock	6、 Filing	7、 Heating	8、 Bubbling
9、 Display Screen			

4.1.1 "▲", "▼" key:

(1) Press the "▲" or "▼" key to set the temperature. Each time you press the "▲" key, the temperature increases by 1°C; Each time the "▼" key is pressed, the temperature is reduced by 1°C.

(2) Temperature range:

◎ Celsius temperature: 30 ~ 42°C.

◎ Fahrenheit temperature: 86 ~ 108°F.

4.1.2 "C/F" Fahrenheit/Celsius switch key

(1) Press this key while displaying Fahrenheit to switch to Celsius. Press this key while the display is Celsius, and the display switches to Fahrenheit.

4.1.3 "Bubble" key:

(1) When the bubble function and other functions are turned off, press this key to turn on the bubble function. After the bubble function is on for 30 minutes, it will automatically stop

working. If you need to make bubble again, just press this key again, the bubble function will be turned on.

- (2) When the filtering function is turned on, press the bubble function key, the filtering function will stop immediately. After the bubble function is turned on for 30 minutes, it will automatically stop working. Press the bubble function key again during the bubble process, the bubble function will be turned off.

When both the filtering function and the heating function are turned on, press the bubble function key to start the bubble function. The heating and filtering function are automatically stopped. After the bubble function is turned on for 30 minutes, it will automatically stop working or press the bubble function key during the bubble process, the bubble function will be turned off. At the same time, the filtering function and heating function are started.

4.1.4 " " Filter on/off key:

- (1) When the filtering function is turned off, press the key once to turn on the filtering function. Press the filter function again to turn off.
- (2) When the filtering and heating functions are turned on at the same time, press the filtering key again, and both heating and filtering functions are turned off at the same time.
- (3) When the bubble function is turned on, neither the filtering function nor the heating function can be turned on by pressing the filtering key and the heating key.

4.1.5 " " Heating on/off key:

When both the heating and filtering functions are turned off, press the heating key, both filtering and heating function are started immediately

When the heating is turned on, press the heating key again, the heating function is turned off, and the filtering function can still continue to work.

When heating to the set temperature, it enters the heat preservation state. When the pool temperature is 2 degrees lower than the set temperature, the heating function starts automatically.

When the bubble function is turned on, neither the filtering function nor the heating function can be turned on by pressing the filtering key and the heating key.

4.1.6 " " Child Lock/Unlock Key

Press the key for 5 "  " seconds, can achieve child lock function, that is, in any state, all keys are locked, can not be used independently. If you want to unlock the child lock, just press the key again for 5 seconds to unlock;

4.1.7 SPA 47°C Manual reset of the temperature protection switch

Take out the reset pole from the PE bag of the accessory box remote control adapter, and then insert into the reset hole, press the reset button to the switch stroke bottom lightly (Press until it is held). See below figure.

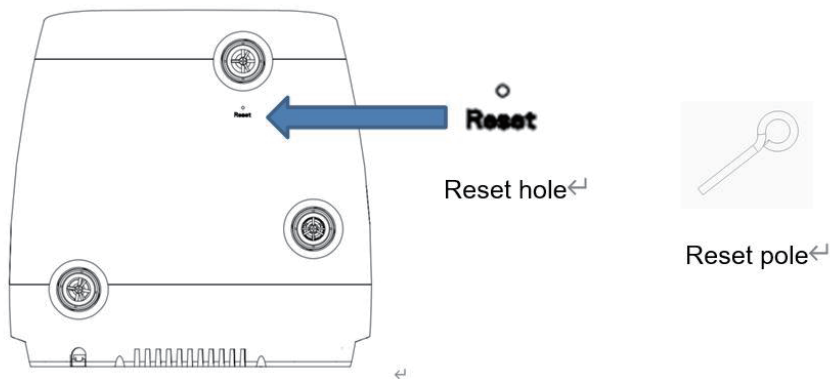

4.2 Drainage of SPA pool

(1)

a: Use the plug in the repair bag to block the outlet at the bottom of the pool. see fig15

b: Open the cap of the outlet pipe under the outer wall of the pool, see fig 16;

c: Connect a white drain pipe in the pool set for drainage, see fig 17;

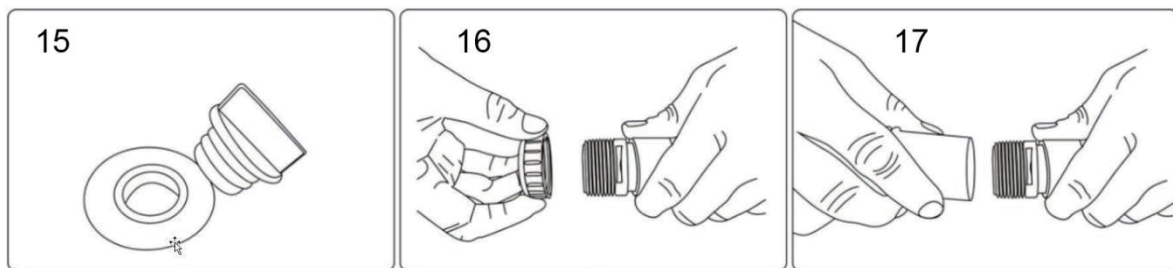

(2) Pour out the water from the SPA pump first. see fig18 . Then connect the outlet of bubble and water outlet. see fig19. Press bubble key and make it work for 2-3 minutes to blow out the remaining water inside the SPA pool.

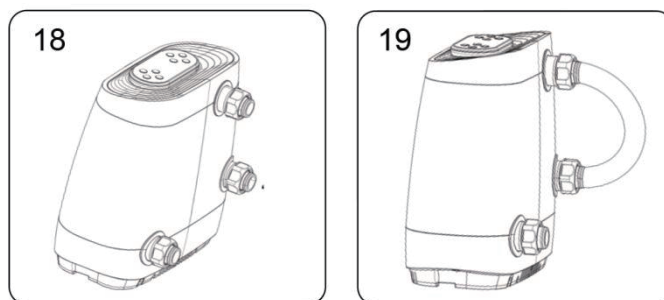

4.3 SPA Pool Filter Cartridge Replacement

Warning: The circuit breaker must be cut off before beginning spa maintenance to avoid severe risk of injury or death.

NOTE: Dirty filter cartridge not only affects the cleaning of water in the pool, but also affects the heating effect of SPA pump. Therefore, it is recommended to clean the filter cartridge regularly according to the water treatment chapter.

(1) First pull off the plug

(2) Cover the water inlet and outlet with the cover included;

(3) Rotate counterclockwise to remove the filter cartridge; (Figure 20)

(4) You can rinse the filter cartridge directly with water (Figure 20), but if the filter cartridge is still dirty or has changed color after rinsing, it is recommended that you replace the filter cartridge.

(5) Install the washed filter cartridge into the SPA pool wall.

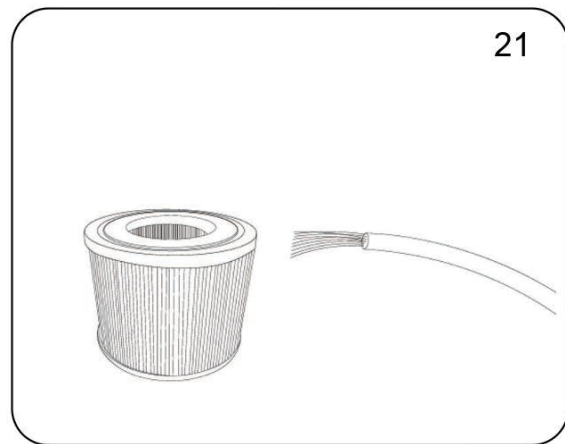
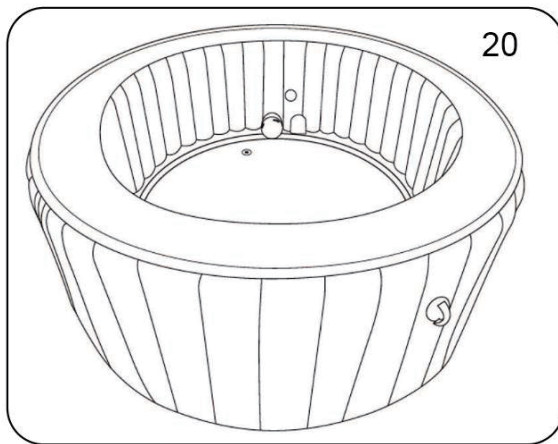

Five. SPA Maintenance

5.1 Water Requirements for SPA

We require the PH value of the water used in the pool to be between 6.5 and 8.5. If the PH value is too low or too high, it will affect the service life of the pool and pump of SPA and bring harm to human health. The damage of SPA caused by the PH value of the water quality will not be covered by the warranty. Therefore, we suggest that customers can use PH test paper to test the water quality before using it.

5.2 SPA Water Treatment

Note: Ensure the cleanliness of the water in the pool is very important for your health. We suggest you do the following things:

- (1) Regularly start the filtration system of SPA pump to clean the water in SPA pool;
- (2) The filter cartridge of SPA pump must be cleaned every 3 days, and the filter cartridge must be replaced on average once a week according to the frequency of use.
- (3) Replace the water in the pool every 3 days and then clean the pool clean with a clean cloth.
- (4) SPA can be treated with suitable chemicals for SPA, and the water in SPA pool can be disinfected with appropriate disinfectant every day. The disinfectant will kill bacteria and viruses in the water. Please consult the local SPA distributor/seller for details before use.

Note:

Before using pool chemicals, please consult your local SPA Retailer for more maintenance information. Pay close attention to the chemical manufacturer's instructions. Abuse of SPA or improper use of chemicals, resulting in SPA damage and life injury, will not be covered by the warranty.

After each use of the SPA pool, we recommend that you use bromine reagents and the chemical floaters to disinfect the water in the pool. First open the cap of chemical floaters, then add some bromine reagents, and cover the cap. Put the floaters into the SPA pool. We recommend that you activate the bubble function while the water in the pool is being disinfected, so that the circulation of water and disinfection can be more sufficient. Please look at the following illustration:

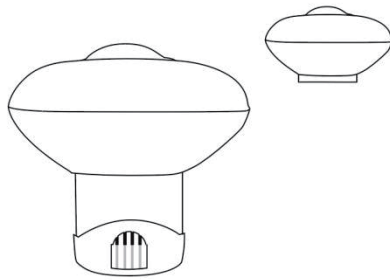

Warning: SPA cannot be used while it is being sterilized. The maximum amount of chemicals should not exceed 20 tablets, otherwise the chemicals will destroy SPA, and chlorine-containing chemicals should not be used.

5.3 Clean SPA

Dirt on the body, swimsuit and scale in water are easy to adhere to SPA pool and pump body after heating, so it is necessary to wipe the surface of SPA pool with soft cloth and neutral detergent frequently, and a fine brush is used to wipe the scale attached to the water inlet and outlet to prevent scale from blocking the water inlet and outlet, thus affecting the normal use of SPA pump.

Note: Do not use hard brushes to clean the surface of the pool.

5.4 Repair SPA

If the SPA punctures and leaks air, the repair patch in the attached repair kit can be used for repair. Before repair, the SPA should be drained and deflated, and the damaged part should be wiped clean. Cut the repair patch into a shape of appropriate size, coat it with matching glue, and paste it onto the damaged part. Do not use the newly repaired SPA within 12 hours.

5.5 SPA storage

According to the above-mentioned SPA drainage steps, ensure that the water in the SPA pool and the control box has been drained, take out the filter cartridge, and wipe the SPA pool and SPA pump clean with cotton cloth, which can prolong the service life of the SPA. It is recommended that you store the SPA in the original package and put it in a warm and dry place.

Note:

It is strictly prohibited to store the SPA pool in an environment below zero degrees Celsius. Plastic is easily brittle and shortens its service life when exposed to low temperature environment or exposed to the sun light for a long time. Damage caused by improper storage in winter will not be covered by the warranty.

If SPA is not used for a long time, the residual water in SPA pool and SPA pump must be dried, otherwise peculiar smell will be caused by deterioration of water quality.

Six. Simple troubleshooting

Failure	Possible phenomena	Solution
SPA Cannot run	Not powered on RCD Trip Residual current device damage	Check power supply Reset RCD Or the power cord load is not up to 2000W Or 10A If you can still work normally, please contact the after-sales service
SPA No heating	Temperature set too low Filter cartridge too dirty The water level is too low Electric heating does not work	Set a higher temperature Cleaning/replacing filter cartridge Continue to fill the water and raise the water level Call for help
The wave-making system does not work	When the pump temperature is too high The temperature Protection 30 Minutes are automatically turned off SPA automatic pump protection	Disconnect the plug and wait for the pump to cool before starting Restart Bubble button. If it cannot be started, please contact after-sales service
Water filtration does not work	Filter cartridge dirty The inlet and outlet pipes are blocked Control box error	Cleaning/Replacing filter cartridge Check if the water inlet and outlet are blocked by foreign bodies such as scale If you still can not work normally, please contact the after-sales service
SPA The buzzer of the pump sounded continuously	Buzzer does not stop	Cleaning/Replacing filter cartridge Check if the water inlet and outlet are block by foreign bodies such as scale Press and hold the filter key 3 seconds to eliminate sound
SPA Water tank leaks	SPA Pool damage	Use the provided repair patch
Water is not clean	Insufficient filtering time Filter cartridge clead. The water is not clean. Improper handling of water.	Increase filtration time Cleaning/Replacing of filter cartridge Replace the water Refer to the chemical instruction operation

Trouble	Description	Faults phenomena	Fault cause	Fault check and maintenance
E1	The malfunction of temperature control sensor	The digital tube displays the trouble code "E1". The heating function cannot be used while the filtering and wave-making can still work	Short circuit or open circuit of temperature sensor	Please contact customer service for professional maintenance

E2	High temperature protection indication	The digital tube displays the trouble code "E2". All functions will not work.	When the water temperature from the pool to the pump exceeds 47°C, the electronic control system automatically provides electronic protection to prevent people from scalding	Step 1: Turn off the power Step 2: Steps to solve 1) Confirm that the pool water temperature is between 20°C and 40°C, and the normal display and function can only be restored after the restarting and the temperature is normal. 2) Remove foreign bodies from the inlet and outlet of the pool. Step 3: Power on again to use (if the alarm cannot be cleared, please contact customer service)
E3	47°C temperature limiter is tripping alarm	The digital tube displays trouble code "E3" and all functions will not work.	When the water temperature detected by the 47°C temperature limiter is higher than 47°C, the temperature limiter will trip protection.	Step 1: Turn off the power Step 2: Steps to solve 1) Confirm that the water temperature of the pool is below 40°C Step 3: Power on again to use (if the alarm cannot be cleared, please contact customer service)
E4	80°C temperature limiter is tripping alarm	The digital tube displays trouble code "E4" and all functions will not work.	When the water temperature detected by the 80°C temperature limiter is higher than 80°C, the temperature limiter will trip protection.	Step 1: Turn off the power Step 2: Steps to solve 1) Make sure the water temperature is below 40°C 2) Remove foreign bodies from the inlet and outlet of the pool. 3) It is recommended to be used at ambient temperature of 10-30°C. 4) Check whether there is leakage in the pool. Step 3: Power on again to use (if the alarm cannot be cleared, please contact customer service)
E5	The water pressure switch is tripping alarm	The digital tube displays trouble code "E5" and all functions will not work.	The inlet and outlet of the pool are blocked; The filter of the pump is too dirty and blocked,; The water level is too low; The water pump is damaged; The water pressure switch is damaged	Step 1: Turn off the power Step 2: Steps to solve 1) Clean the mesh of the pool inlet and outlet 2) Clean or replace the filter 3) Check whether the water level is too low 4) Make sure that the transparent cover of the inlet and outlet of the pool is removed 5) Check whether there is leakage in the pool Step 3: Power on again to use (if the alarm cannot be cleared, please contact customer service)
CHG +FIL	150 hours filter alarm	The code of"CHG-FIL" is displayed in a loop on the digital tube, and the product will continue to work during the alarm.	When the filter is opened or heated, the total filter working time is over 150 hours	1. Long press the filter button 3-5S to cancel 2. Clean or replace the filter element