

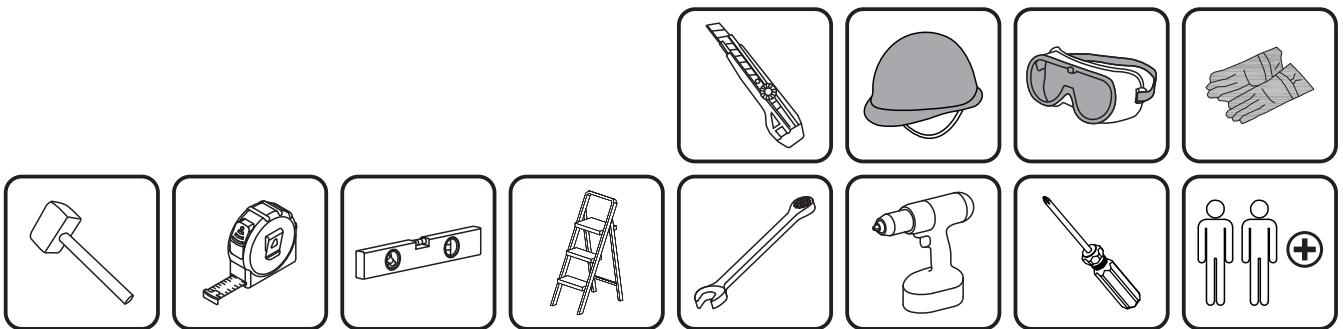

INbma074V01\_GL

845-432

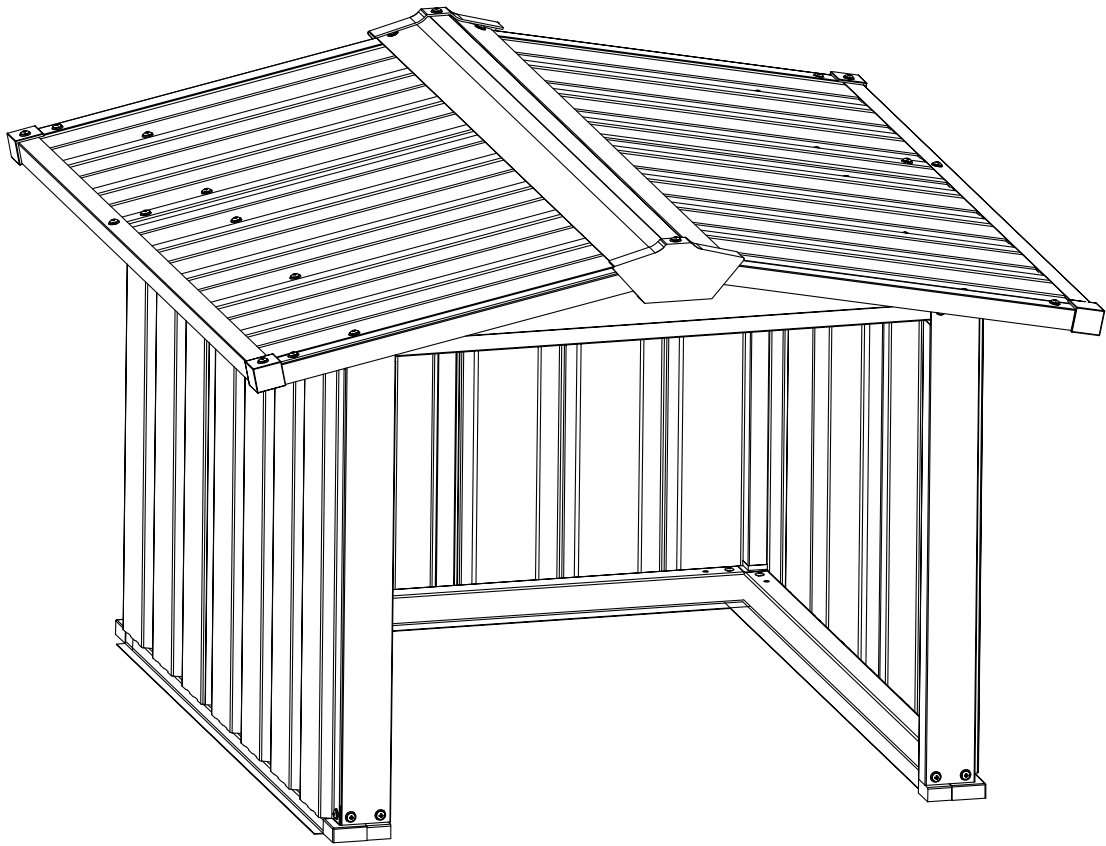







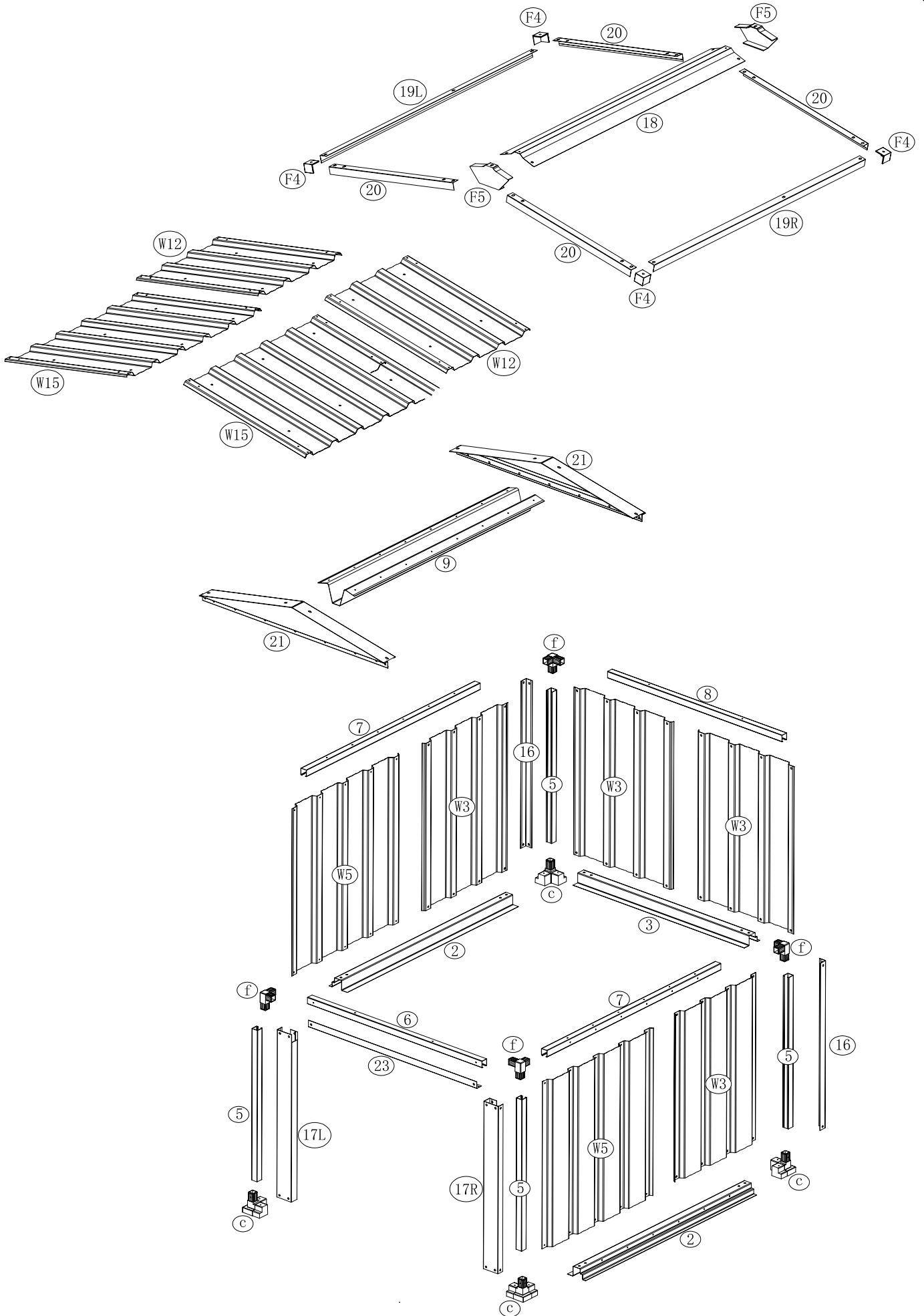

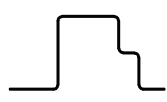
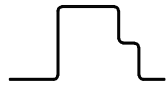





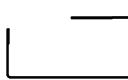
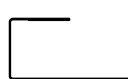
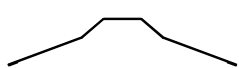





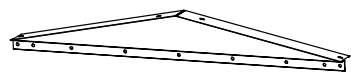

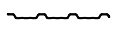
IMPORTANT, RETAIN FOR FUTURE REFERENCE: READ CAREFULLY

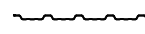

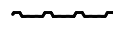

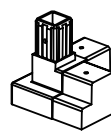
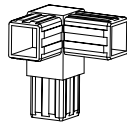
Tools Recommended

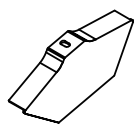
# ASSEMBLY & INSTRUCTION MANUAL

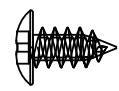

NO.	PART.	Qty.
2	 717.7mm	2
3	 610.7mm	1
5	 455mm	4
6	 622mm	1
7	 729mm	2
8	 622mm	1
9	 797mm	1
16	 503mm	2
17L	 503mm	1
17R	 503mm	1
18	 886mm	1
19L	 886mm	1
19R	 886mm	1
20	 450mm	4

NO.	PART.	Qty.
21		2
23	 600mm	1
W3	  503mm	4
W5	  503mm	2
W12	  442mm	2
W15	  442mm	2
c		4
f		4
F4		4
F5		2
F7		104 +1(spare)
S4		114 +1(spare)

NO.	PART.	Qty.
2	 717.7mm	2
3	 610.7mm	1
c		4
S4		6

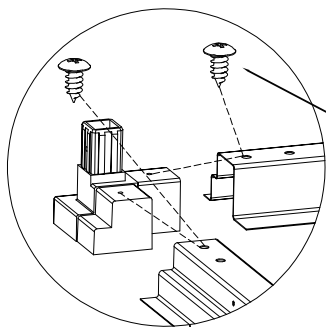
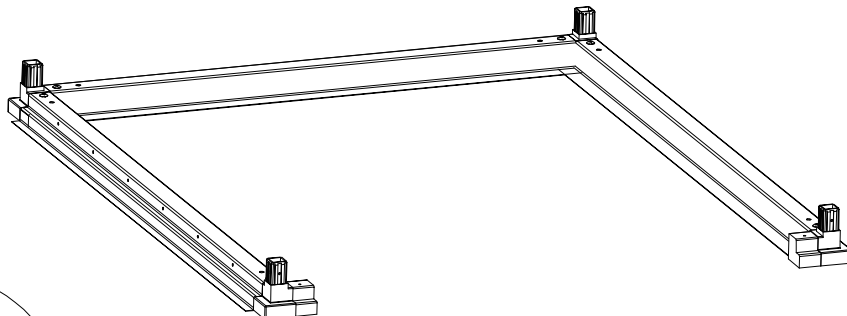



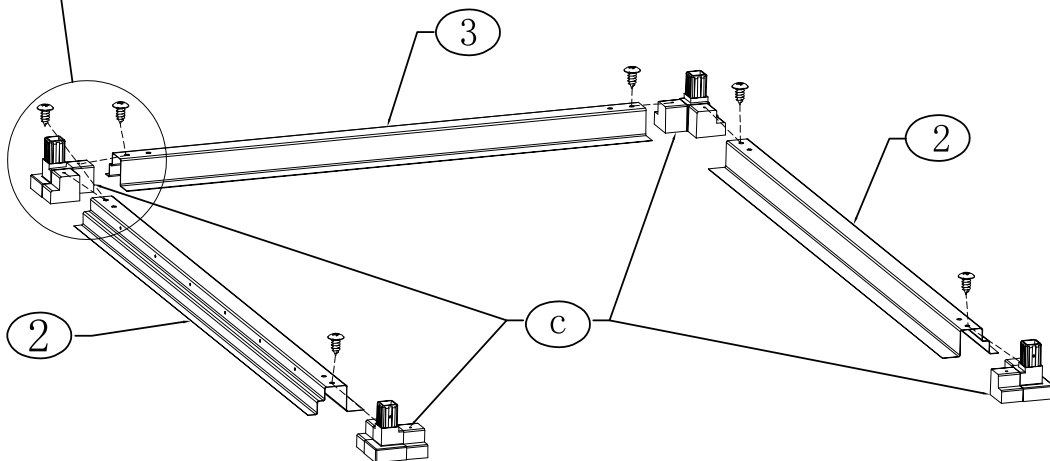

S6

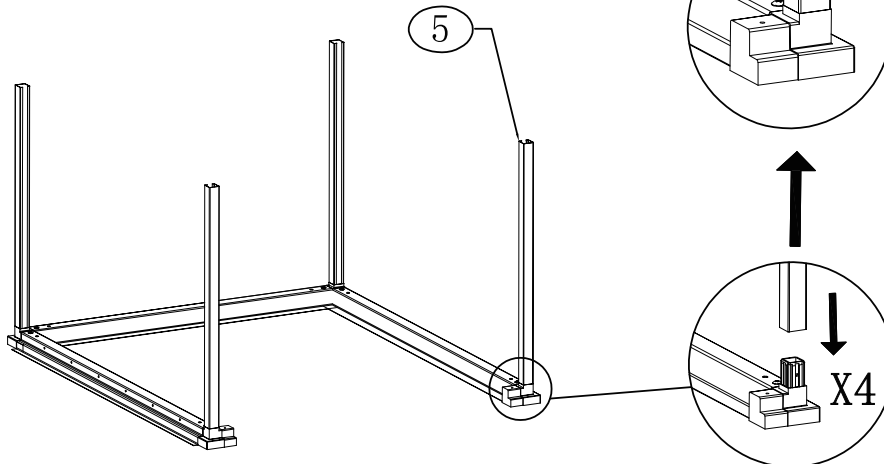





NO.	PART.	Qty.
5	 455mm	4

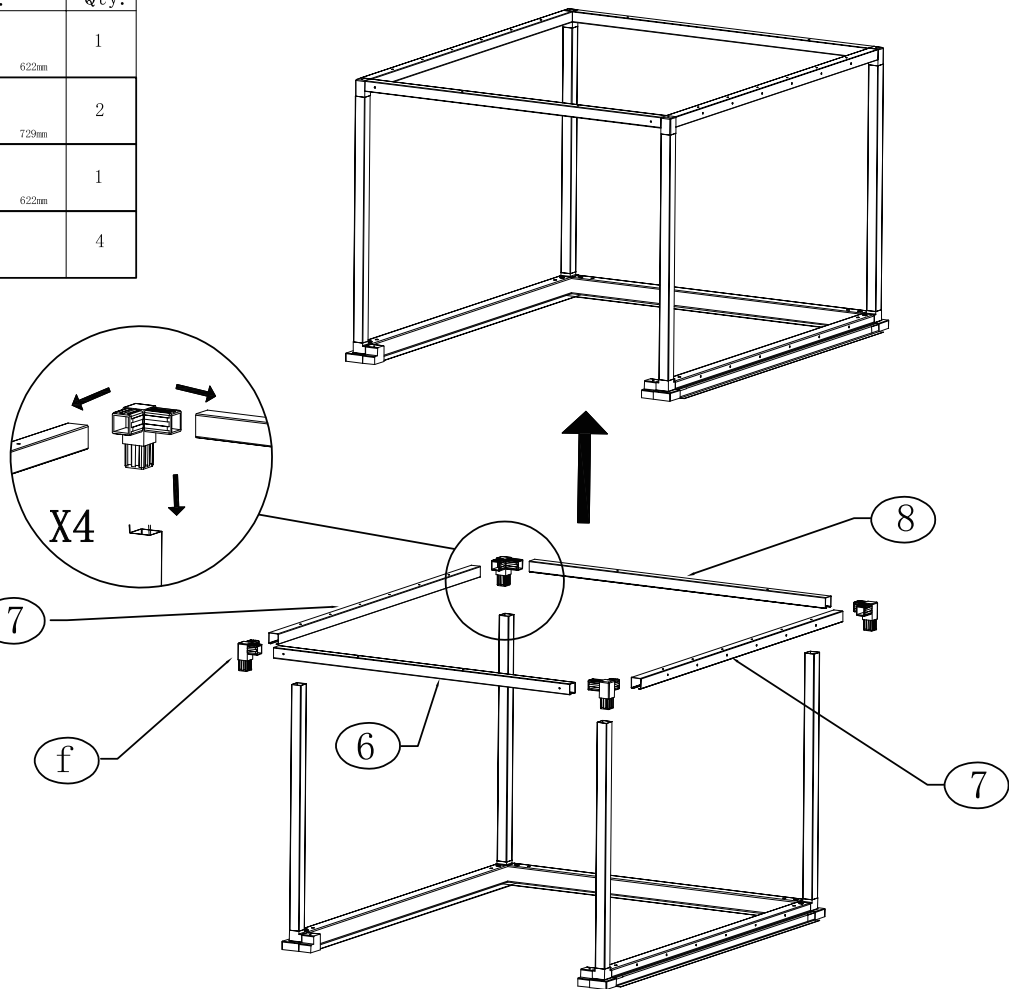



NO.	PART.	Qty.
6	 622mm	1
7	 729mm	2
8	 622mm	1
f		4



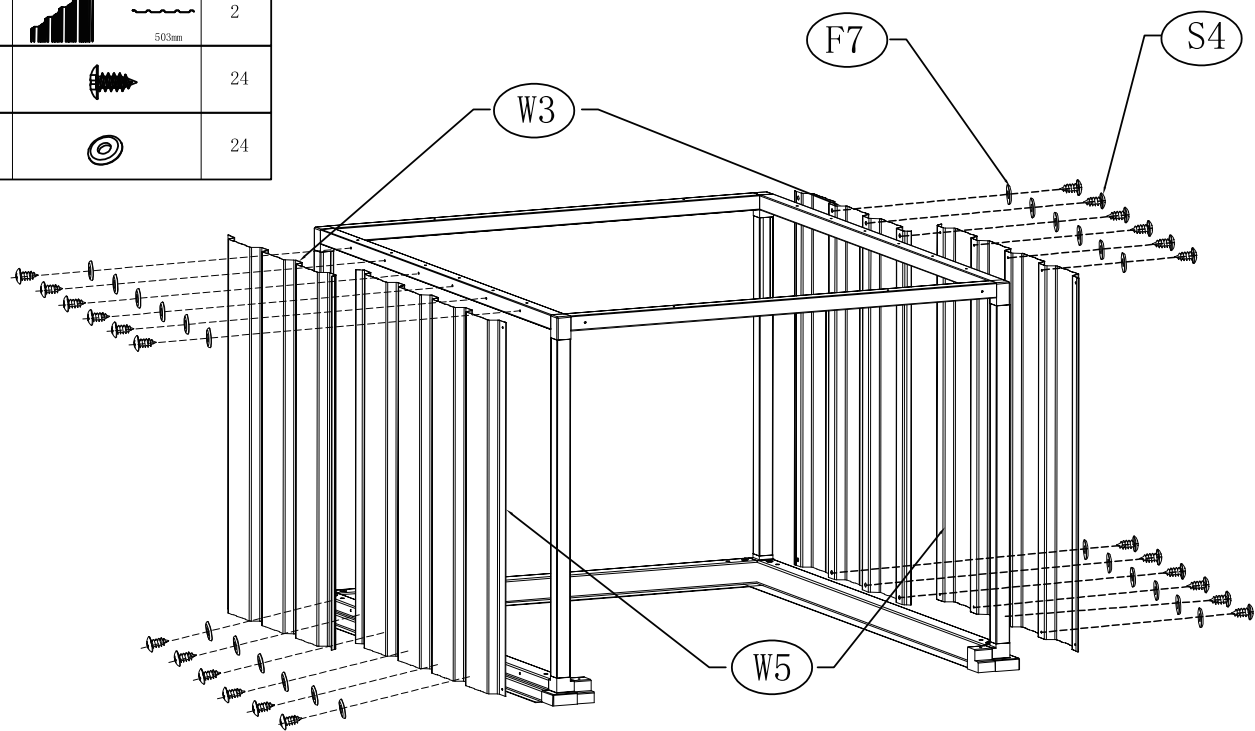

NO.	PART.	Qty.
W3	 503mm	2
W5	 503mm	2
S4		24
F7		24



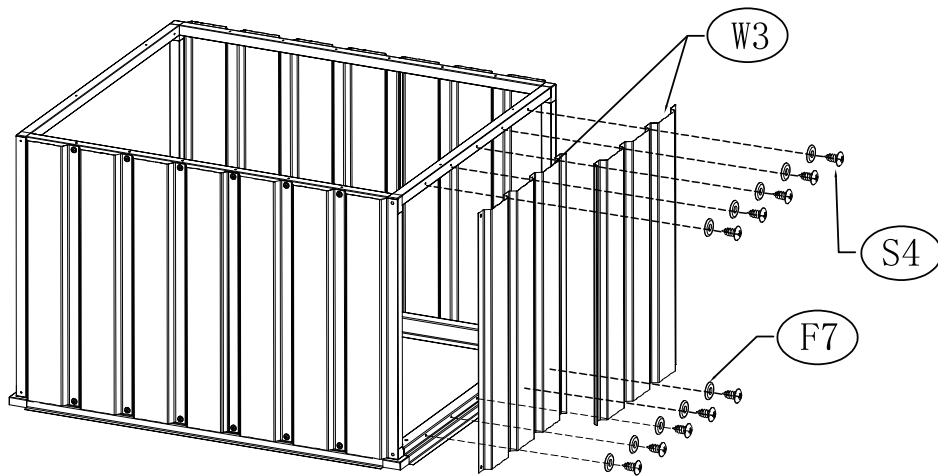

NO.	PART.	Qty.
W3	 503mm	2
S4		10
F7		10



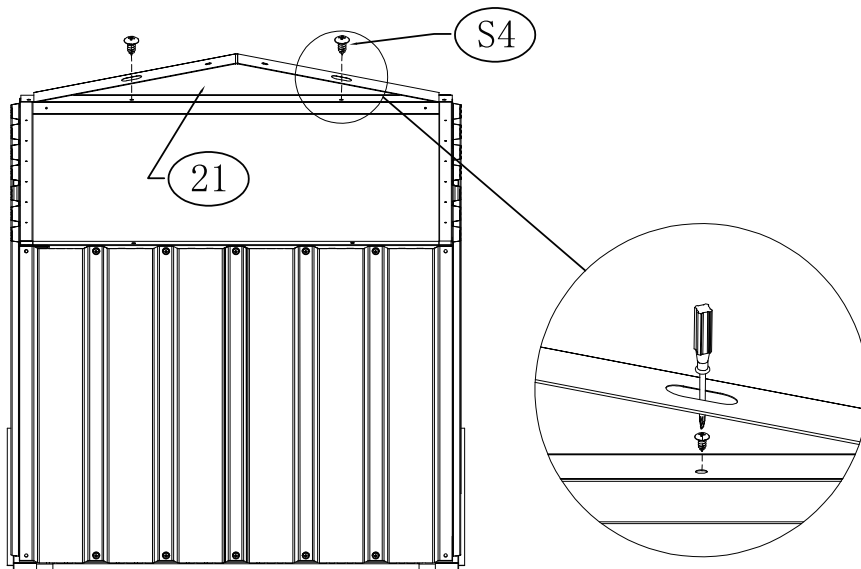



NO.	PART.	Qty.
21		1
S4		2

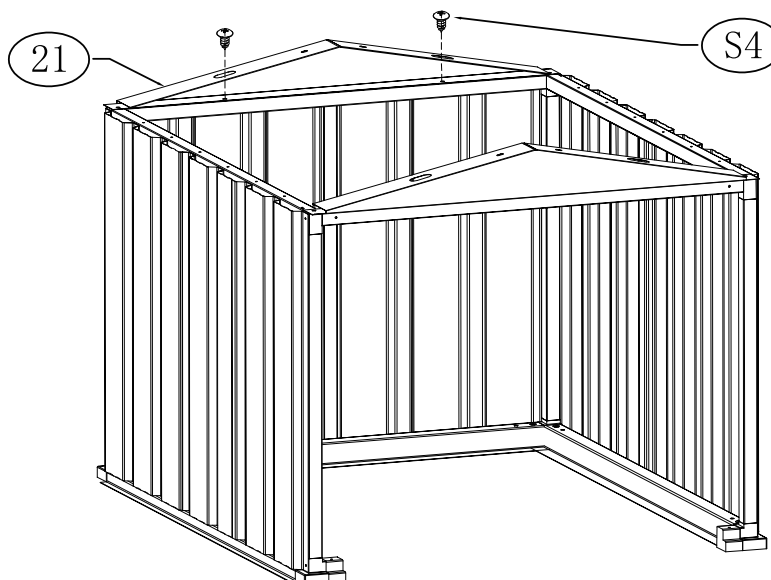



NO.	PART.	Qty.
21		1
S4		2

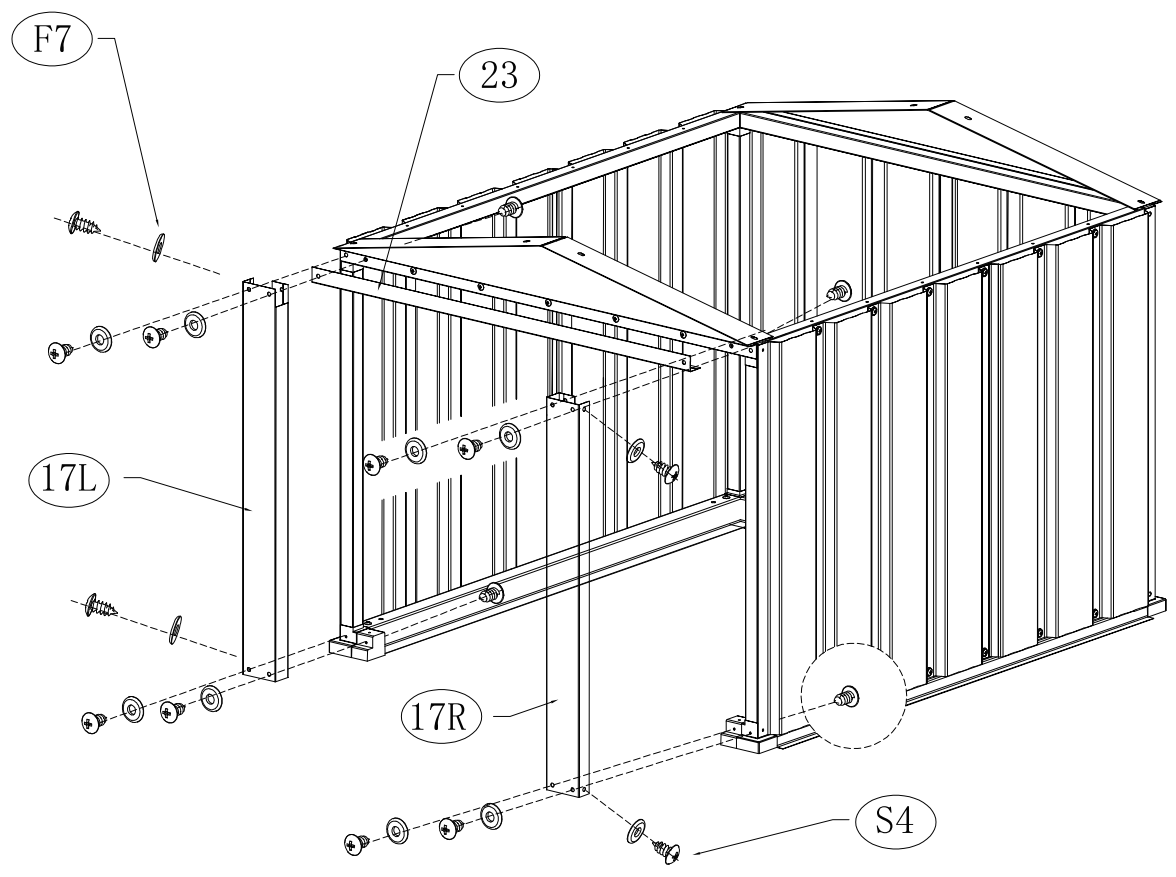
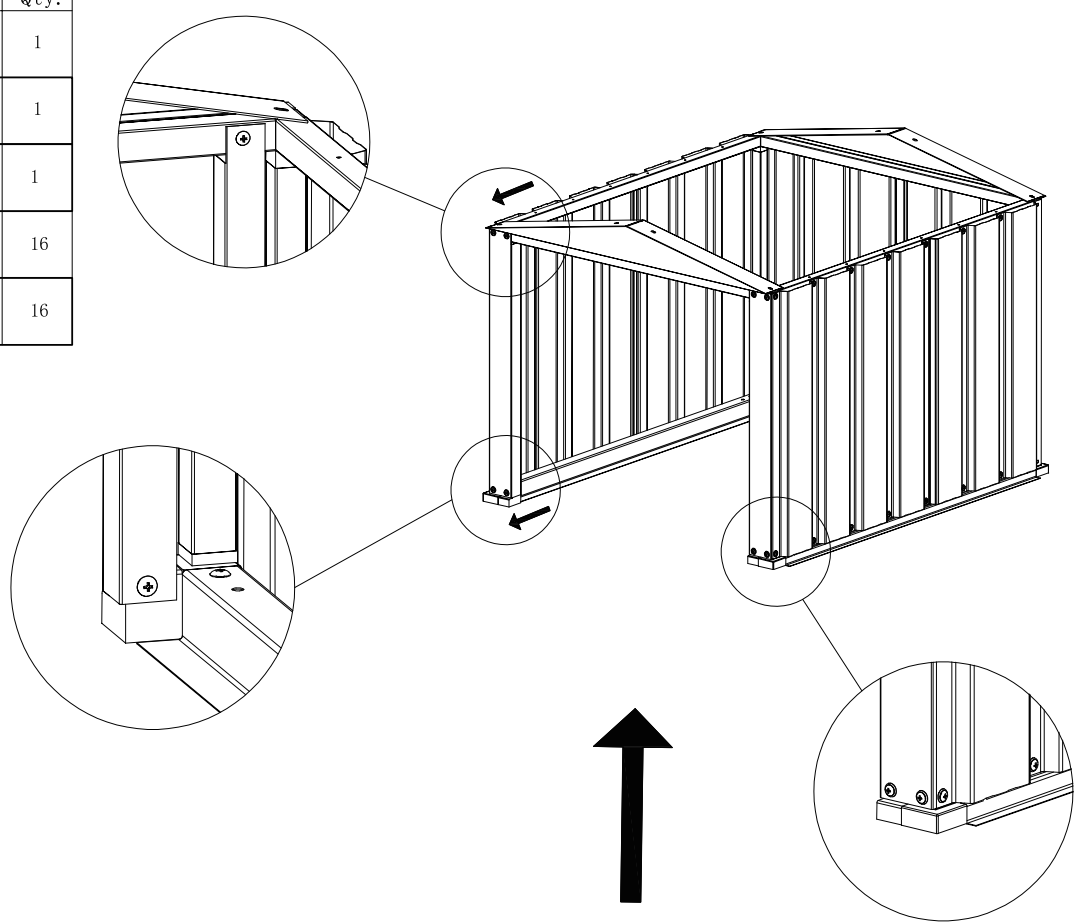

NO.	PART.	Qty.
17L	 503mm	1
17R	 503mm	1
23	 600mm	1
S4		16
F7		16



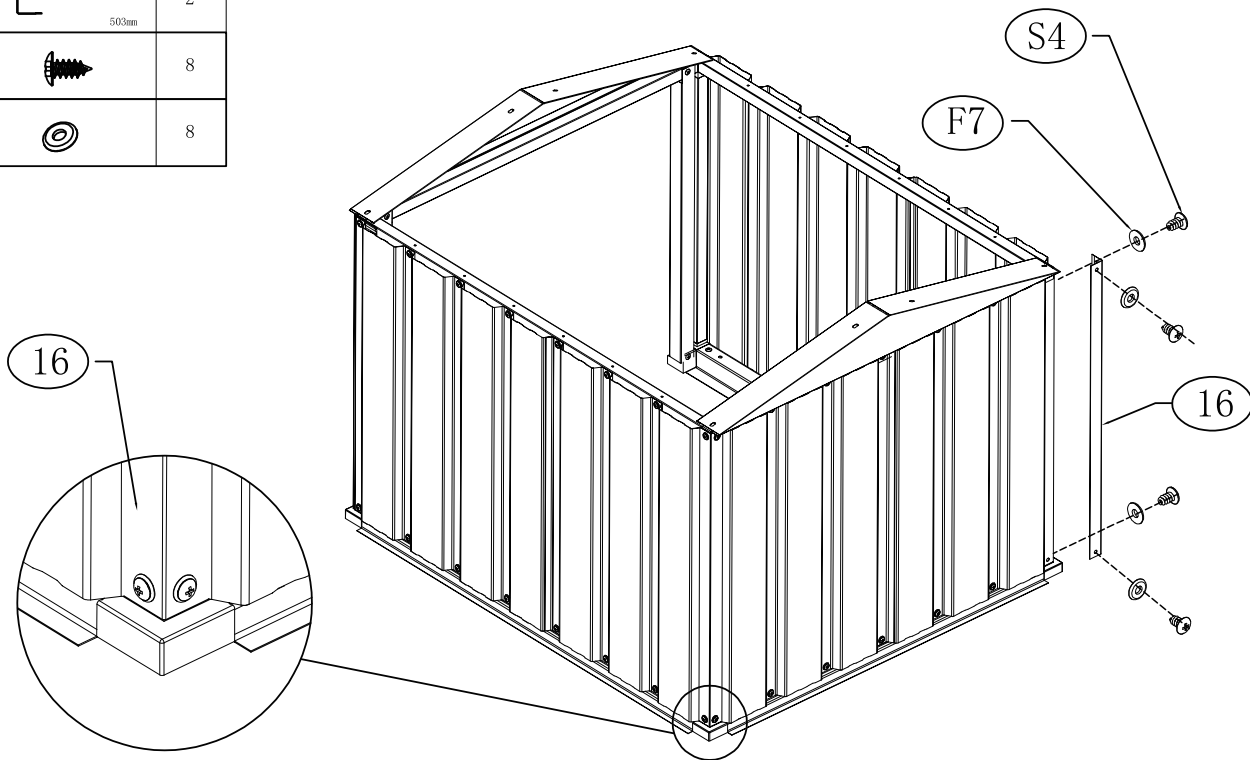

NO.	PART.	Qty.
16	 503mm	2
S4		8
F7		8

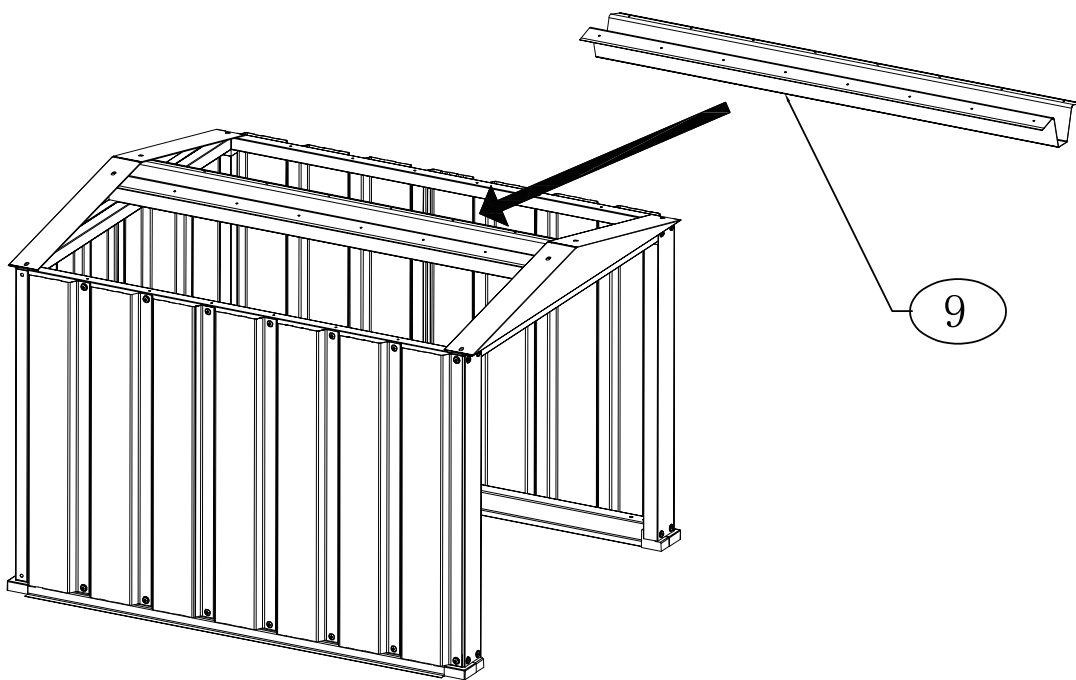

NO.	PART.	Qty.
9	 797mm	1







NO.	PART.	Qty.
W15	 442mm	2
S4		12
F7		12

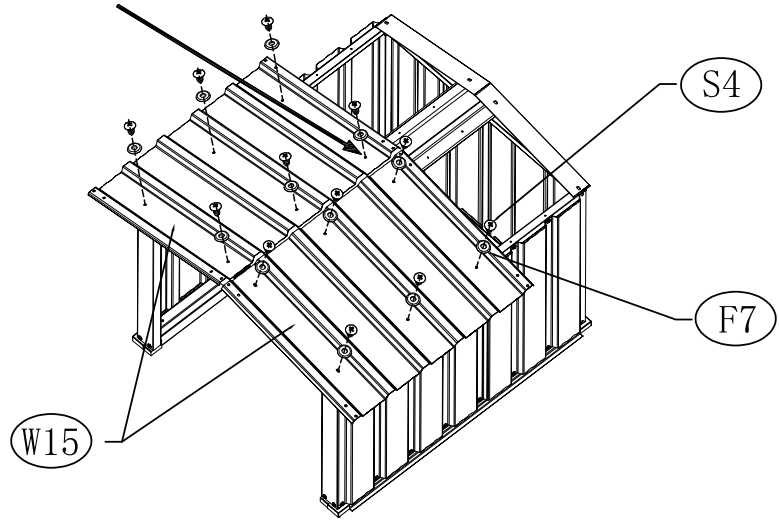

Place the side with smaller distance between holes and edges on the top



NO.	PART.	Qty.
W12	 442mm	2
S4		14
F7		14

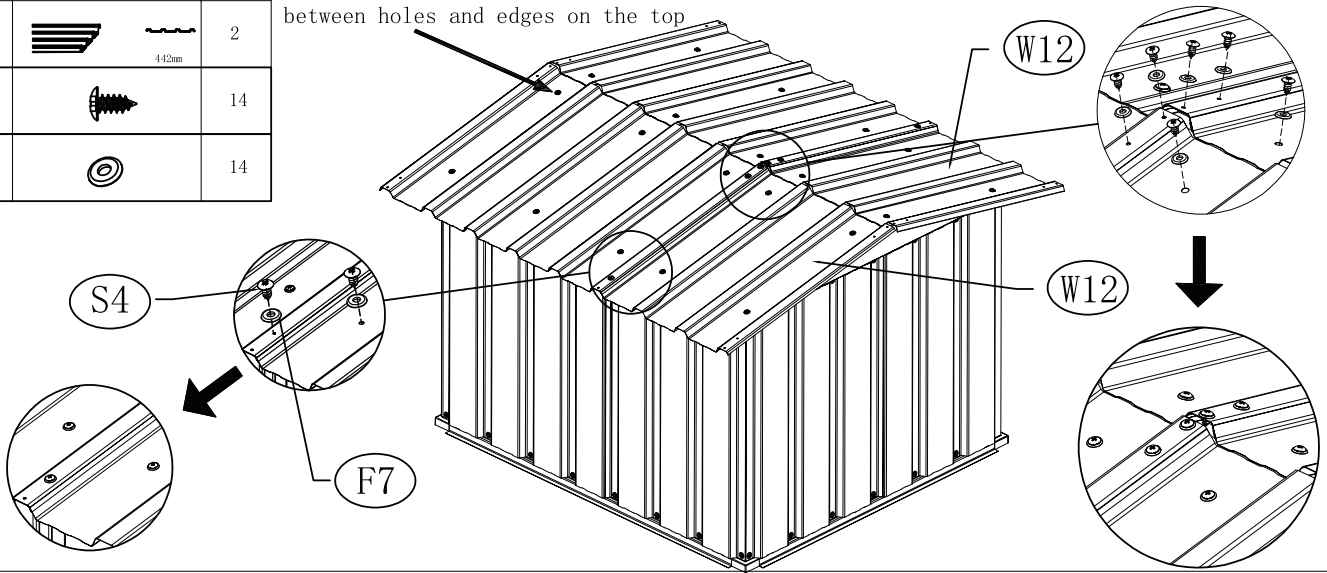



Place the side with smaller distance between holes and edges on the top



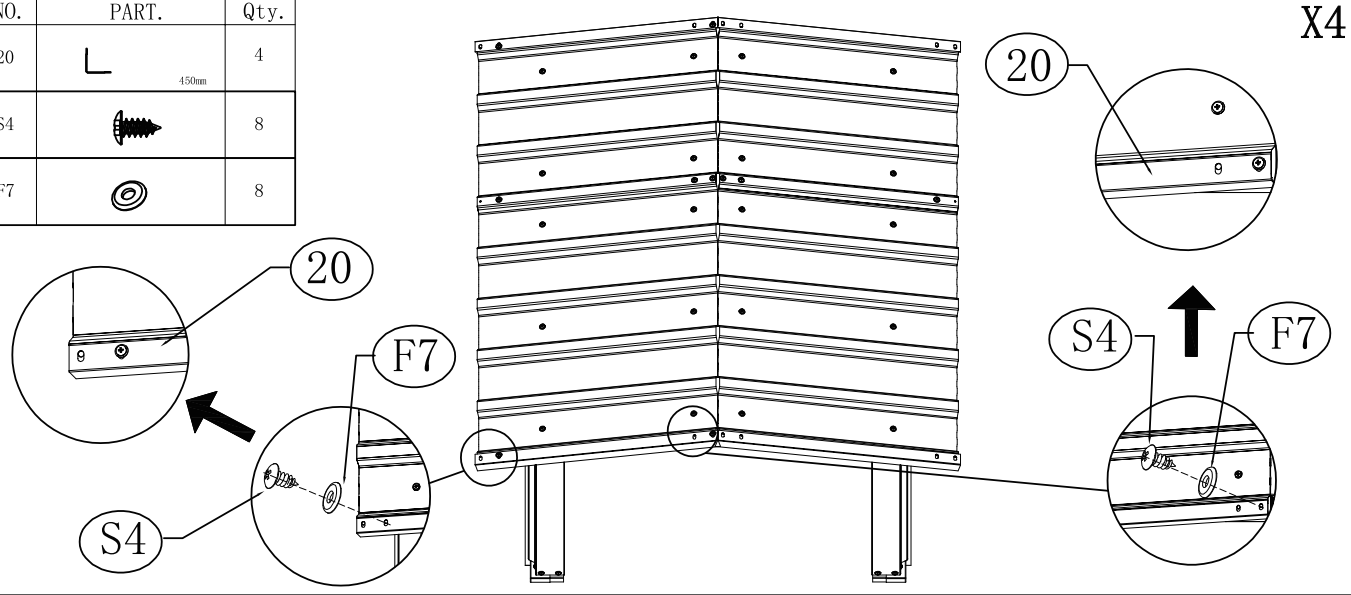



NO.	PART.	Qty.
20	 450mm	4
S4		8
F7		8

X4

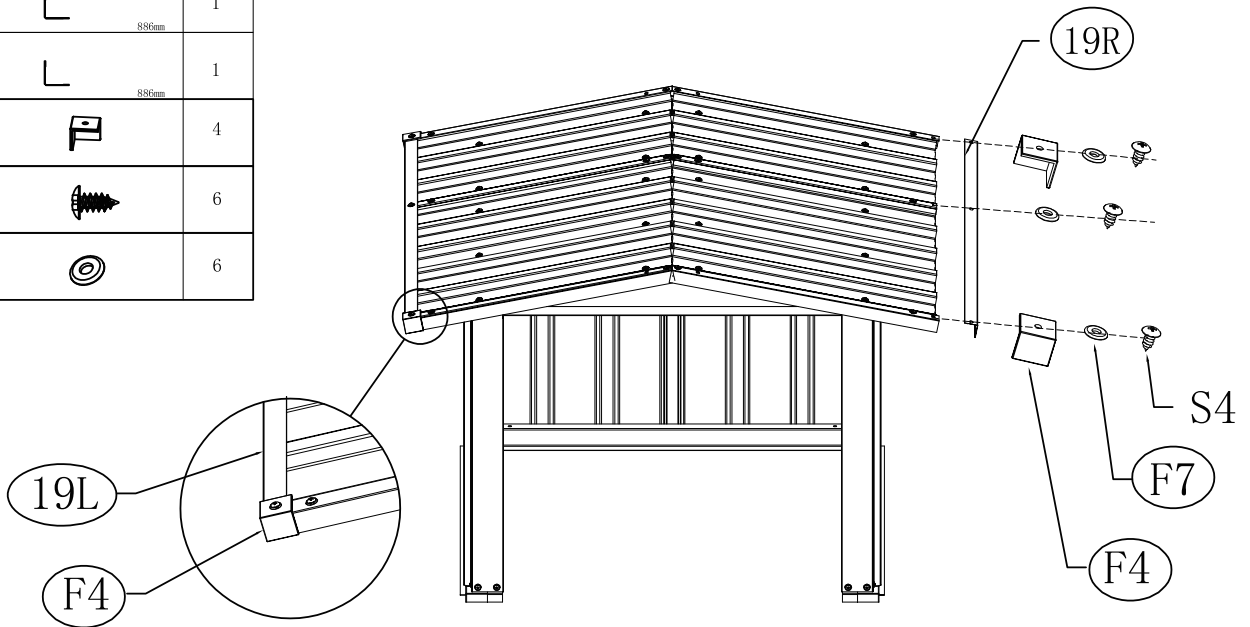

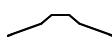
NO.	PART.	Qty.
19L	 886mm	1
19R	 886mm	1
F4		4
S4		6
F7		6



NO.	PART.	Qty.
18	 886mm	1
F5		2
S4		6
F7		6

