

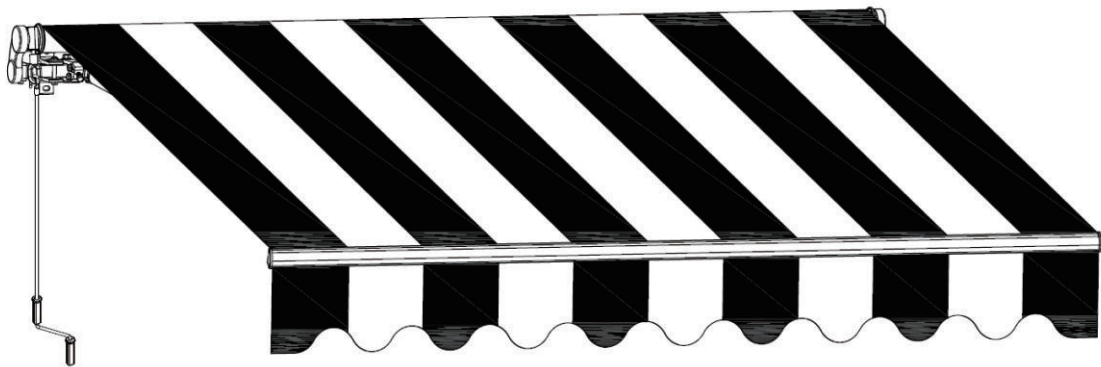

INboa003V01\_US\_UK

**840-149**



IMPORTANT, RETAIN FOR FUTURE REFERENCE: READ CAREFULLY

# ASSEMBLY & INSTRUCTION MANUAL

Thank you for purchasing our Retractable Awning! We hope you will find joy in our product for many years to come.

To ensure your personal safety during installation and to get the most out of your investment, please read this entire manual before beginning the installation process.

We recommend installing this awning by two people. If you feel that this process is too difficult to do on your own, we advise that you seek assistance from a local building or home improvement contractor.

Please contact our customer support line for help if you have any problem or need assistance when assemble, have missing or defective parts, or any other issues, we will try our best to help solve your problems.

We can also offer you the assembly video if you want.

**Please prepare below tools before assembly. (Not included)**

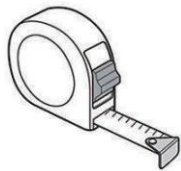

Measuring tape

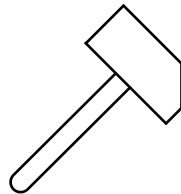

Non-metallic mallet

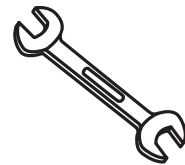

Wrench  
(wrenches of M17 and M14)



Cross screwdriver

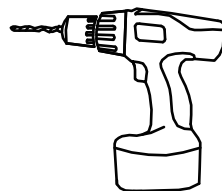

Power drill with  
14 mm drilling bit

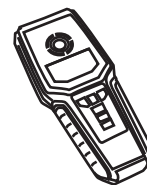

Chalk line leveler

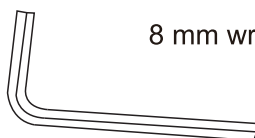

8 mm wrench

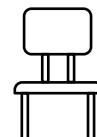



Two ladders or very sturdy chairs

# ASSEMBLY INSTRUCTIONS

## WARNING

Improper installation and operation of your awning can result in severe personal injury as well as product failure not covered by warranty. Please follow all instructions carefully or contact technical support for assistance.









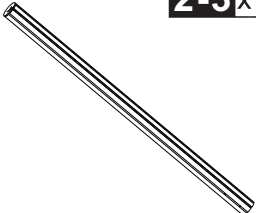
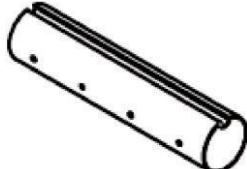
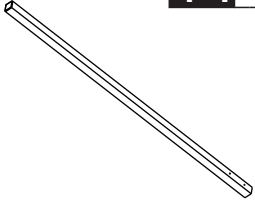
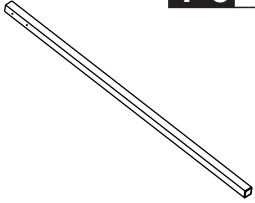

### Before you proceed, please read the following safety precautions:

	<p>DO NOT remove the safety wrap that secures the awning arms until instructed to do so. The awning arms will spring open and can cause serious injury if handled inappropriately. DO NOT stand facing front of the awning when cutting off binds between arms. Hold tightly and stretch slowly until completely open.</p>
	<p>Proper location and fastening of the wall brackets is critical. Please follow instructions in the manual. Failure to securely fasten all brackets could result in the collapse of the awning and cause personal injury or death.</p>
	<p>Keep children away from assembly area.</p>

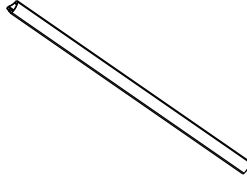
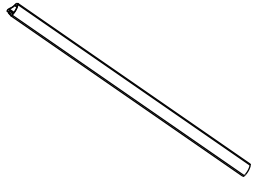

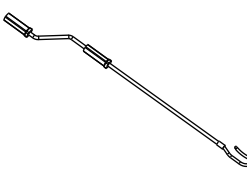
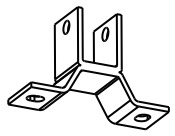
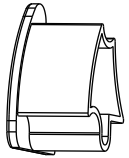
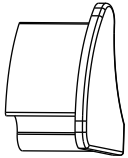

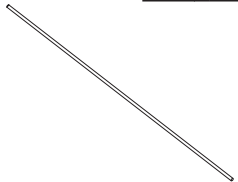
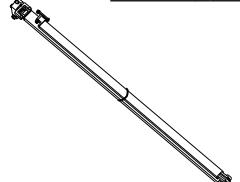
## Safe Installation and Operation

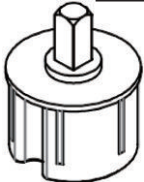
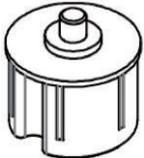
1. Never install it in high and windy places, as the sunshade may drop and hurt someone.
2. Don't use it in places that have vibrations or impulses.
3. Don't use it in places with high temperature such as walls near furnaces.
4. Don't put heavy things on the frame as it may fall down and cause damage.
5. Please close the awning in storm conditions, such as excessive windy and rain.
6. Never use it for other purposes other than suggested.
7. Be careful with your fingers during installation.
8. Two adults are needed to move and install the sunshade as the product is big and heavy.
9. Please use all the screws and nuts correctly during installation as it is very dangerous if you leave it loose.

**PARTS**

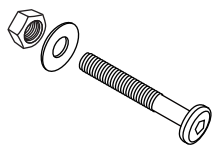
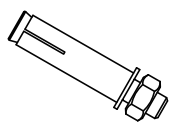
 <b>1 x 1</b>	 <b>2-1 x 1</b>	 <b>2-3 x 1</b>	 <b>3 x 1</b>
 <b>4-1 x 1</b>	 <b>4-3 x 1</b>	 <b>5 x 1</b>	 <b>6-1 x 1</b>
 <b>6-3 x 1</b>	 <b>7 x 1</b>	 <b>8 x 1</b>	 <b>9 x 1</b>
 <b>10 x 2</b>	 <b>13-1 x 1</b>	 <b>13-2 x 1</b>	 <b>14 x 1</b>
 <b>16 x 3</b>	 <b>17-1 x 1</b>	 <b>17-2 x 1</b>	 <b>21 x 1</b>
			 <b>22 x 1</b>

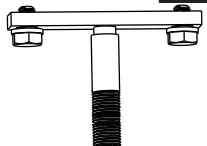
**HARDWARE**

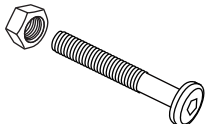
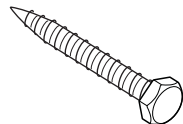
 <b>11 x 2</b>	 <b>12 x 4</b>	 <b>15 x 16</b> +1(spare)
 <b>18 x 2</b>	 <b>19 x 2</b>	 <b>20 x 4</b>
	 <b>23 x 4</b>	

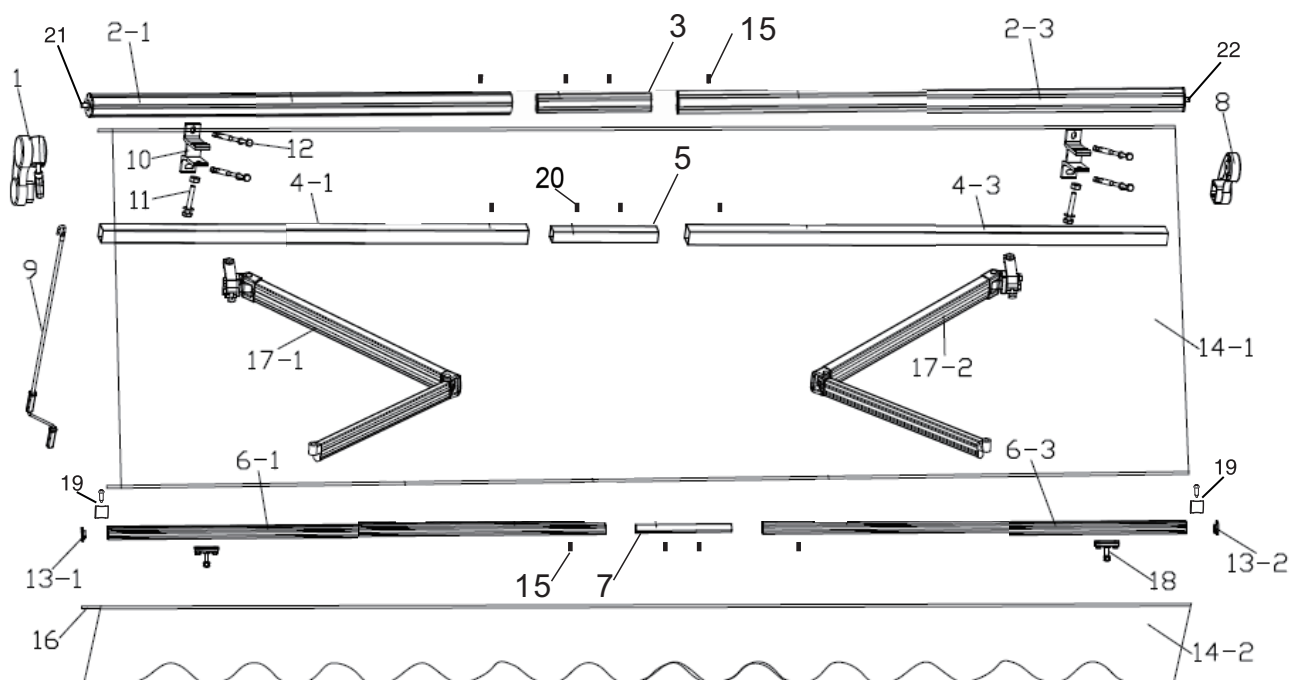

## Preparing Your Work Space

1. Before you begin, it is best to lay out all necessary tools to make setup smoother. Refer to the required tools section for the list of necessary tools.

### WARNING

DO NOT remove the safety wrap that holds the awning arms down. Serious injury can result from removing the wrap too soon.

2. Open the awning box and unwrap each piece carefully to avoid damaging the product.
3. Lay out each piece of the awning to ensure that all pieces are present. Refer to the parts diagram for detailed information regarding parts.
4. Open the small, inner box that contains the small parts and lay them out as well.

**Step 1: Roller assembly**

Keep the rollers aligned, assemble the roller with the connectors and secure it with the corresponding bolts as figure below:

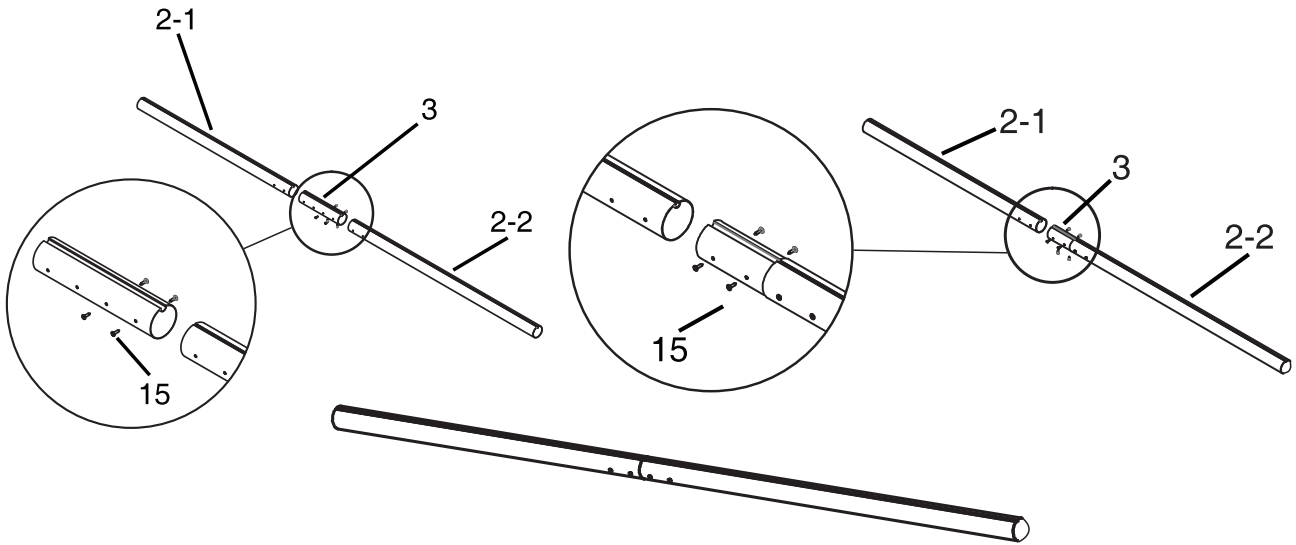

**Step 2: Torsion bar and arm assembly:**

keep the four face aligned , connect the torsion bar with the connectors and secure it with the corresponding bolts as figure below:

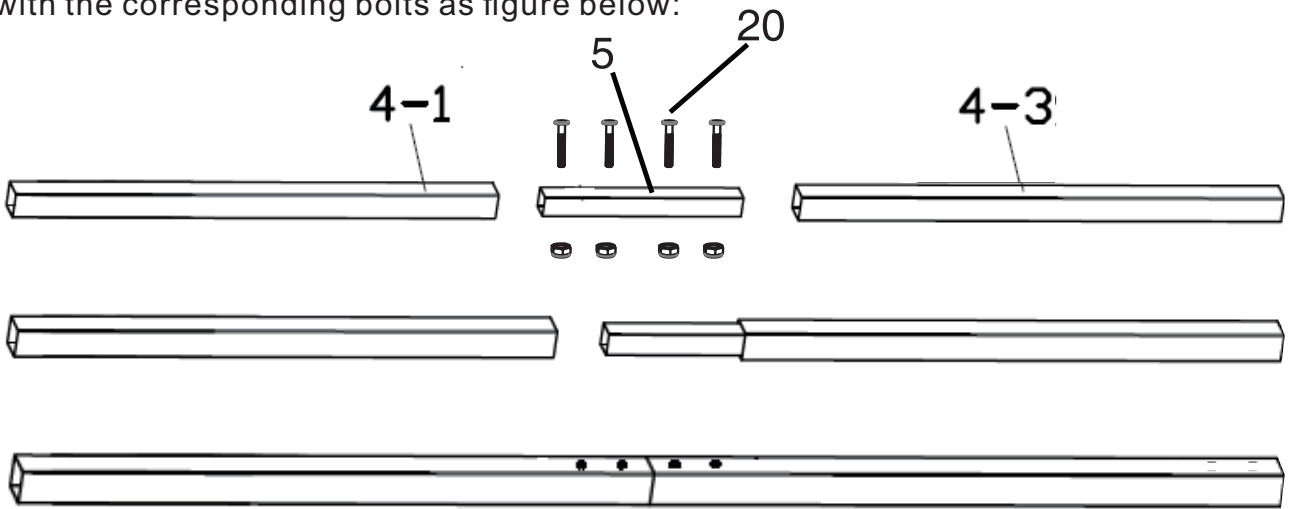

Then assembly the arm to the torsion bar as figure below. Two arms need in the same direction, the rope of arm cannot be unlocked until the whole assembly are complete.

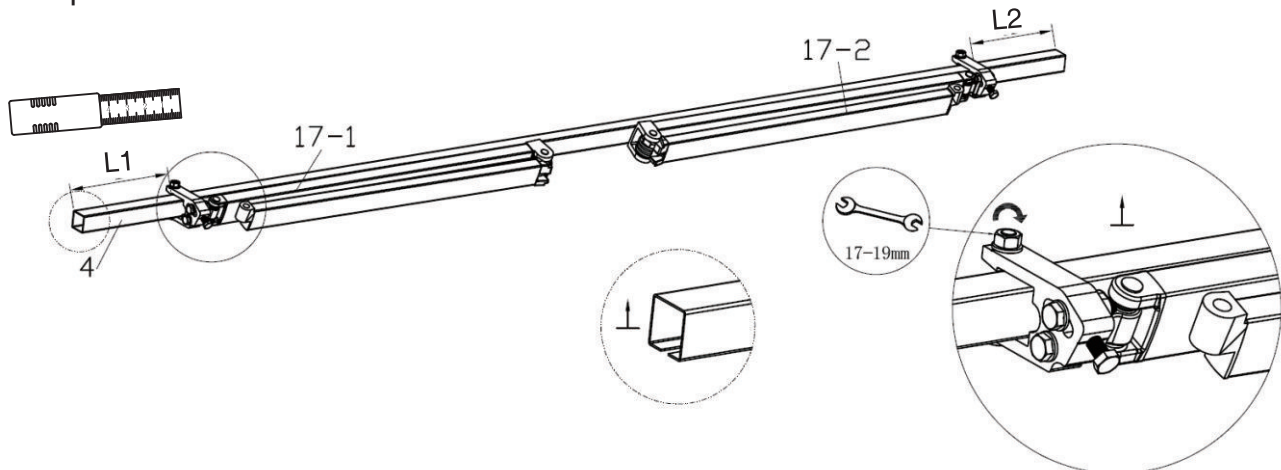

**Step3: Front bar assembly**

Connect the front bar with connectors and secure it with the corresponding bolts as figure below:.(please keep the front bar aligned).

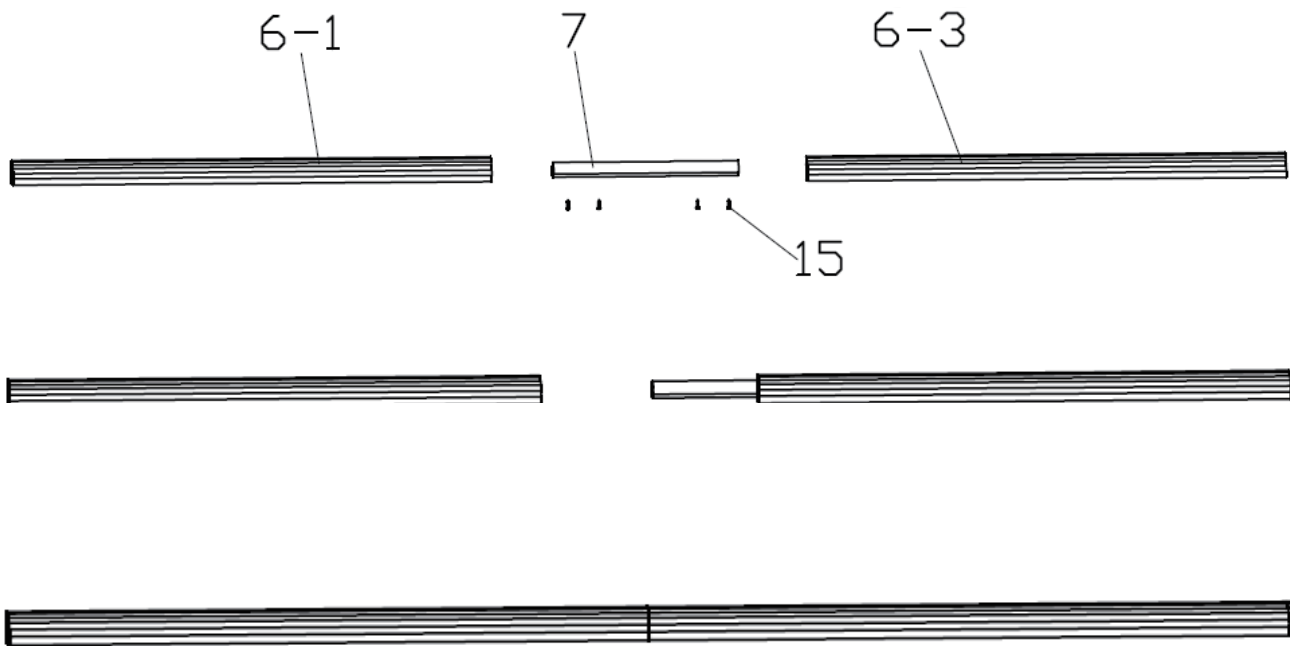
**Step 4: Front bar wrist support assembly:**

Slide the front bar feet into the front bar without tightening. As shown in the figure below:

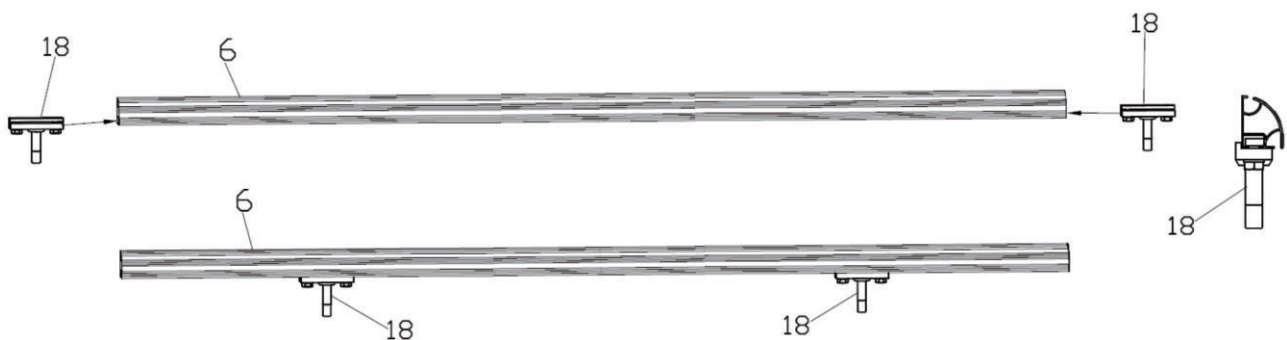

**Step 5: Arms with front bar assembly:**

Put front bar feet bolt through the hole of small arm, then position the front bar. After positioning, tighten the nut with wrench, as figure below:

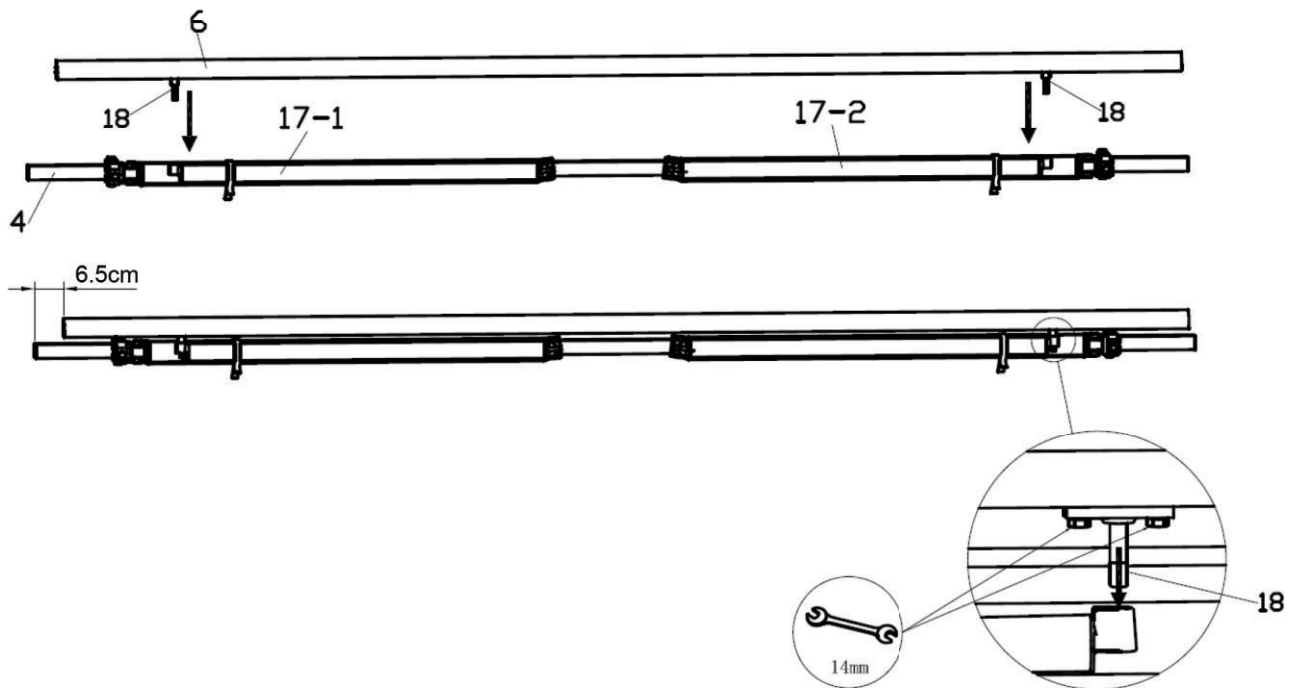
**Step 6: Link the self-locking nut**

Link the self-locking nut into screw which at the bottom of the screw in front bar feet by a wrench, stop when the thread:leakage 1 ~ 2 laps. As shown in the figure below:

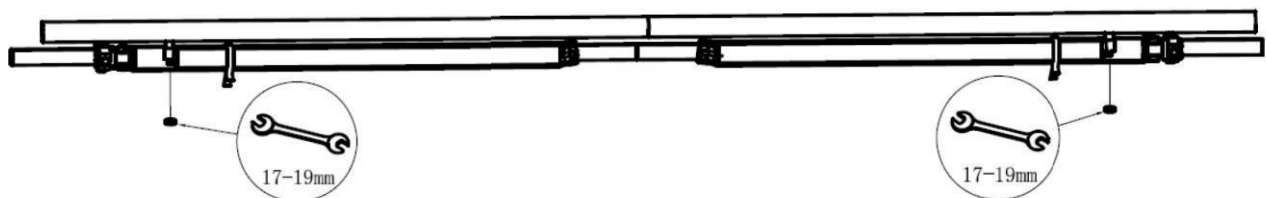

**ATTENTION: BEFORE BLOCKING THE NUT. ENSURE THAT THE ARMS ARE PROPERLY ALIGNED.**



**Step 7: Left roller support with gear box assembly:**

Hammer the left roller support with gear box into the left end of torsion bar by wood hammer, then tighten the left hexagon bolt by 5mm. As shown in the figure below:

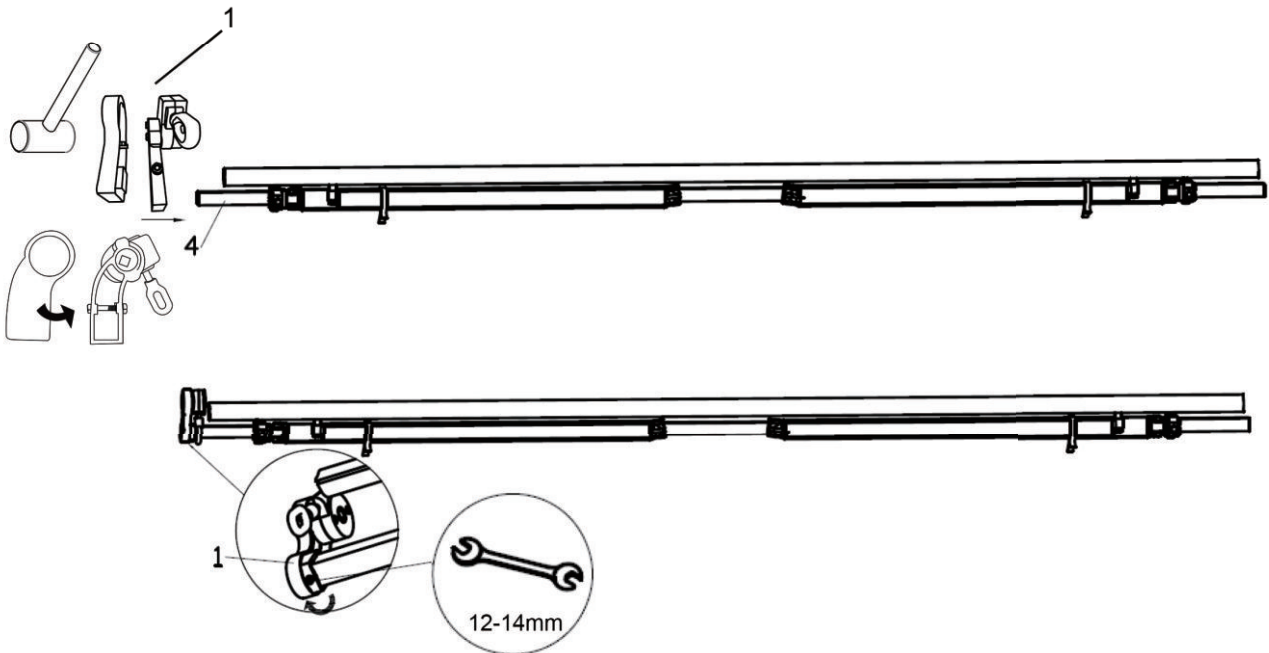
**Step 8: Fabric and valance assembly:**

Open the fabric bag, Spread out both fabric 14A and valance 14B and use the cloth guiding wire to line through the fabric. As shown in the figure below:

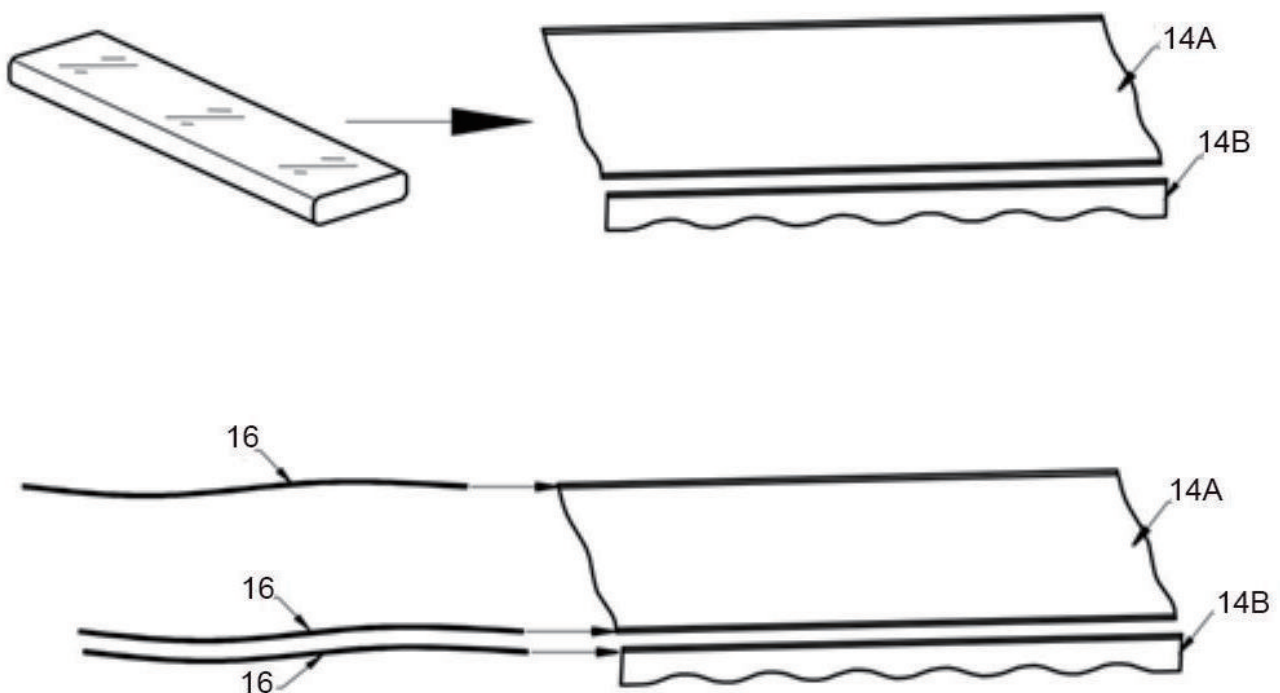

### Step 9: Roll in the fabric on the roller

Roll in the fabric on the roller, pay attention to the fabric direction needed, as shown in the figure below:

Please face up the fabric when assembling. Keep the same spacing  $X$  at both ends. Spread the fabric slowly in case of damage.

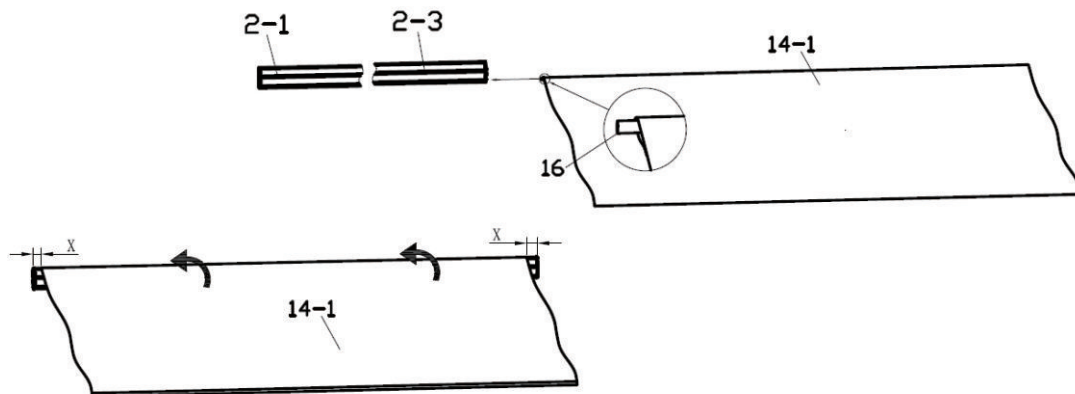

### Step 10:

One end of fabric through the groove of front bar, well-distributed the fabric after pull in all fabric, then insert shaft of roller into the square hole of gear case. As shown in the figure below,

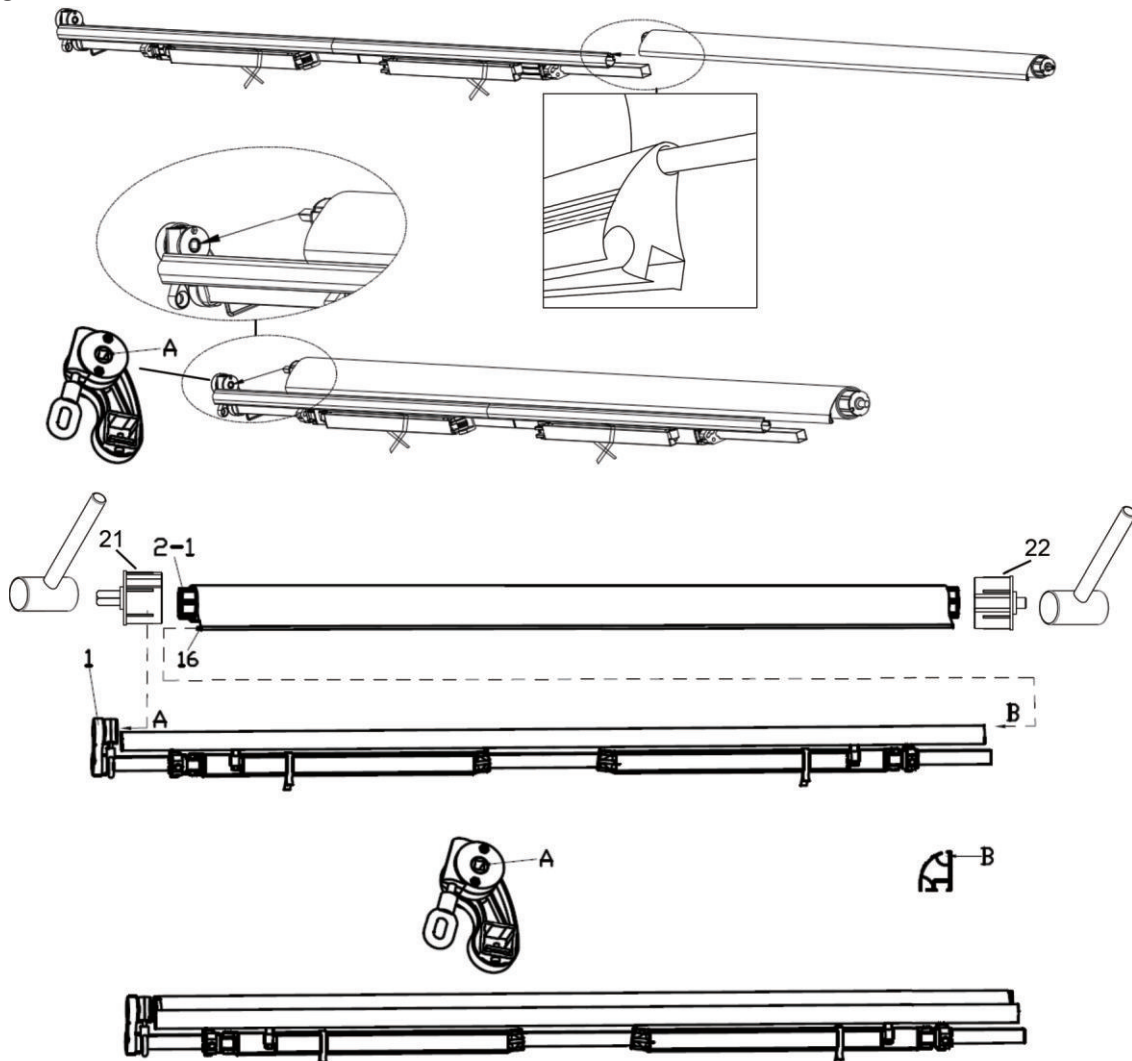

If the part of front bar is a little deformed, please adjust it with tools by yourself.

**Step 11: Right roller support assembly:**

Insert the shaft of roller into roll tube plug , meanwhile insert the torsion bar into the right roller supports with hitting. Then tighten the right hexagon bolt by 5mm Hexagon wrench.As shown in the figure below:

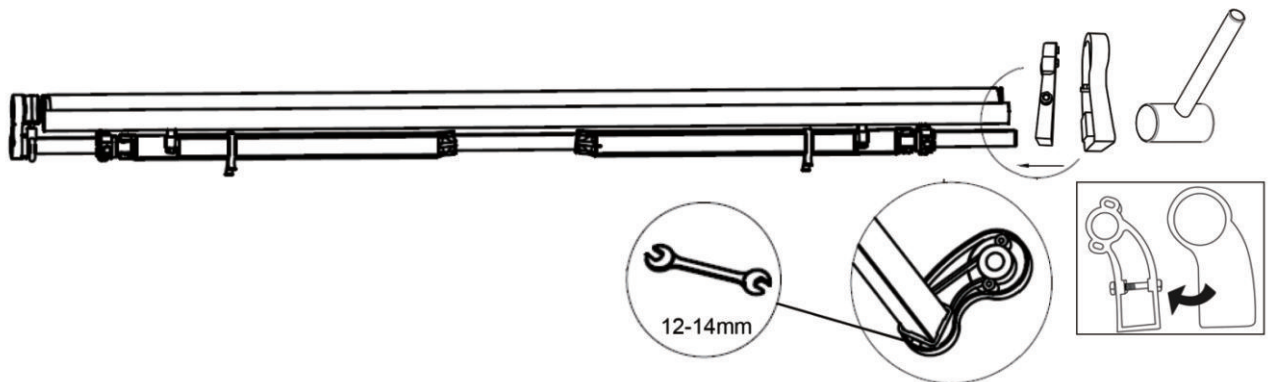
**Step 12: Assemble to make a whole awning**

Make the valance through groove of front bar, pay attention to the direction and make sure the left and right sides on average, then hitting the cover of front bar into end of front bar. As shown in the figure below:

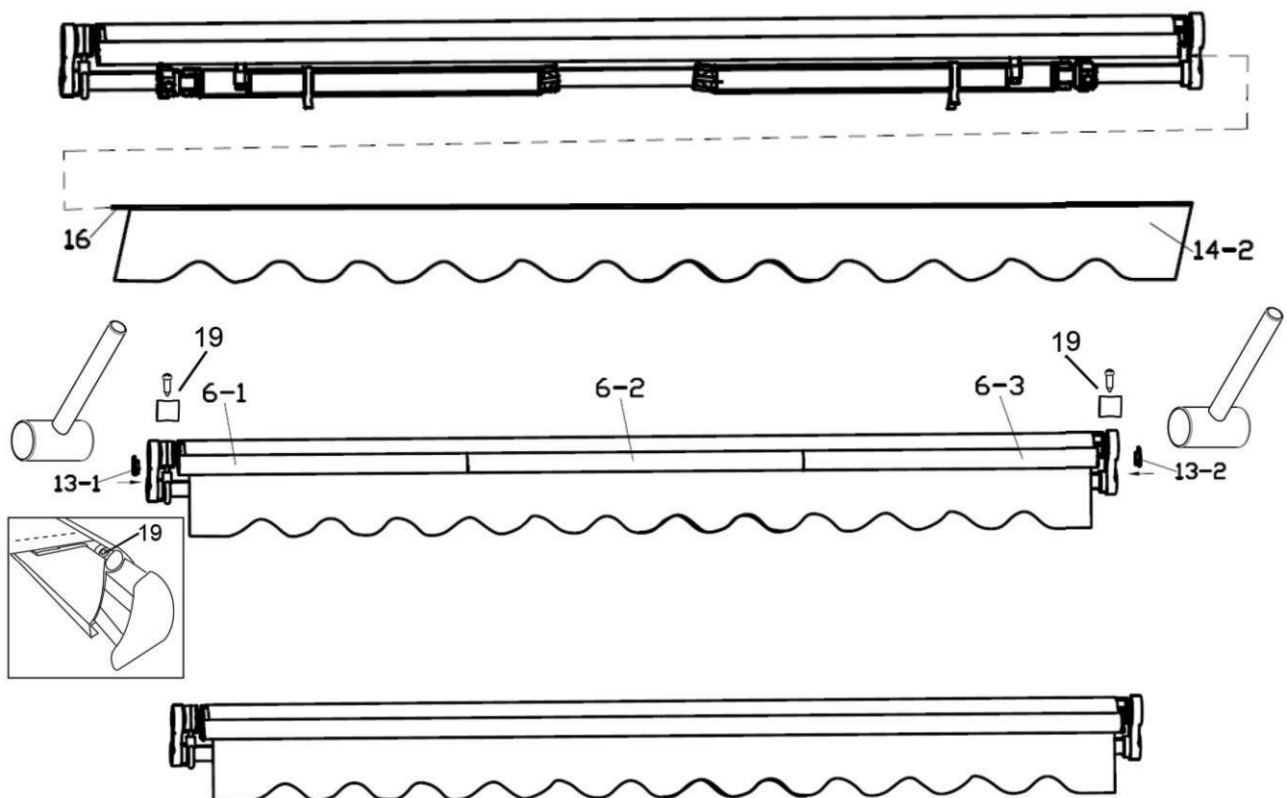

If the part of front bar is a little deformed, please adjust it with tools by yourself.



If you find that the fabric wraps unevenly or that the two arms won't open together at the same time, look at the stability of the two arms. Solution: adjust the arm bar link's position on the front bar outwards, as necessary.

## Specification

Product name	Material and surface treatment	Applicable wall type	Recommended installation height	Applicable weather
Retractable awning  (Please see details on the package)	Materials: Steel tube, aluminum alloy, plastic parts, polyester fabric. Service treatment: Tubes: spray paint and oxidation Cloth surface: PU, UV, waterproof	Reinforced concrete walls, brick walls, and wooden walls	2.5m-4m 8'-13'	The products are used to shield sunshine. Applicable when wind is under level 5. Not suitable for rainy weather.

## Wall Mounting

### Notes about Wall Mounting

This awning can be secured to reinforced concrete, brick and wood wall. However this awning kit only supplies screws suitable for mounting to brick and reinforced concrete walls.

If you wish to secure your awning to wood, please use wood screw of adequate length and of an appropriate diameter to secure the awning to wood beams. The bolt size depends on the size of wood; these can be purchased at a hardware store. We recommend a professional installer for the safest and most secure installation.

Never attempt to secure the wall brackets to loose wall stones or any surfaces that are not absolutely firm!

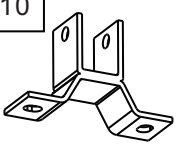
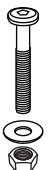
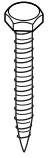
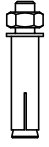
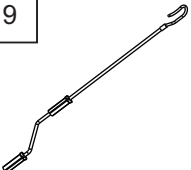
10  Wall bracket 2PCS	11  Hex screw 2PCS	23  Wood screw 4PCS	12  Expansion bolt 4PCS	9  Hand crank 1PC
---	--	---	--	---

## ⚠ CAUTION

Proper location of the brackets is the most important aspect of the awning installation. It is critical that you fasten all the mounting brackets to studs, joists, headers or other major structural components.

## ⚠ WARNING

Failure to securely fasten all the brackets to the wall could result in the collapse of the awning and cause personal injury or death.

## Mounting Height

It is important to take the awning's drop area into consideration before bolting your wall mounts. If you would like to mount above a patio door, for example, please leave at least 8" (20.5cm) above the door frame and be sure that the awning does not interfere with opening and closing the door. The drop angle can only be changed minimally, so take this into consideration when deciding where to place your awning.

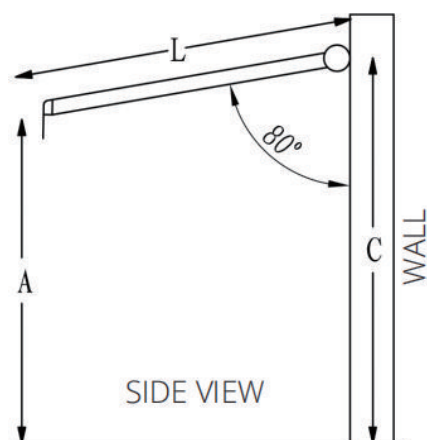

We recommend that the awning surface make an angle of about 80 degrees to the wall when open.

Recommended installation height: 8-13 '(2.5-4m). The ideal drop angle (when fully extended) has already been set in the factory, so you may not have to change the pitch/angle.

### CALCULATIONS:

You can use the following formula to calculate the appropriate angle.

$$C = A + 0.17 * L$$

A = The desired height of the front bar

L = The length of the arm stretched out

C = The height of the wall brackets

## STEP 1

### Measuring the Mount Site

1. Measure the length of your awning along the wall where you intend to install it. This line will be the highest point of your awning and align with the top of the wall bracket. Use a leveler to make a chalk line across the distance.
2. Important: Double check that the line is level all the way across.
3. Be sure that the line is centered over the patio door, window, or other feature, if applicable.
4. Now that you have a straight, centered line, measure the middle point and mark it. This is where the middle wall bracket will be installed.
5. Take a wall bracket and place the top of it, completely level, under the line, as shown in the diagram below. With chalk or a pencil, mark the position of all the wall brackets and their bolt holes. Please note the distance between each wall bracket should be the same.

Awning < 10.8'(3.5m)	Requires only 2 wall brackets total: one for each end of the torsion bars.
Awning = 10.8-14'(3.5-4m)	Requires 3 wall brackets total: one for each end, and one in the middle.

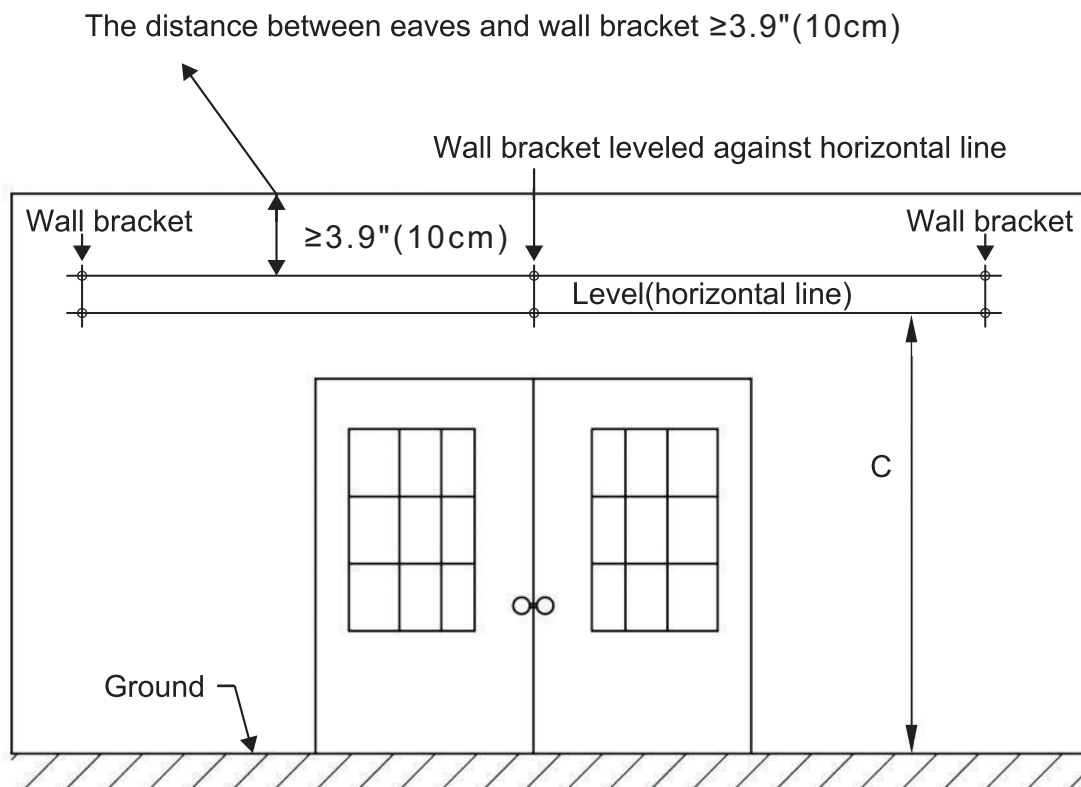

## STEP2

### Drilling the Bolt Holes

1. Now that you have a straight level line across the wall with the locations of the wall brackets and their bolt holes marked, you can drill holes to mount the brackets.

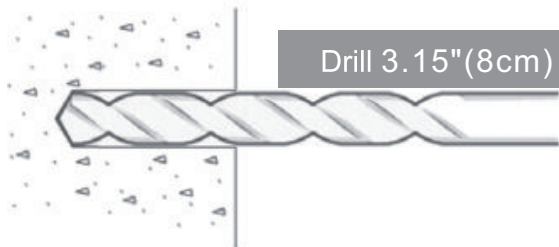

2. Using a 0.55" (14mm) masonry drill bit, drill the first bolt hole approximately 3.15" (8 cm) deep, as shown in the diagram. This must be drilled through solid brick or concrete to offer the necessary support for the awning.

3. Drill the remaining holes exactly as in step 2.

#### WARNING

All bolt holes must be aligned vertically and horizontally to ensure that the awning hangs straight.

Double check alignment before drilling if you are not certain.

#### WARNING

The diameter and depth of your mounting holes must be the same size as the expansion bolts.

## STEP3

### Preparing for Mounting

1. Now that all of your holes are drilled, then insert the expansion bolts.

2. It may be necessary to drive the bolts in with a wooden (or other non-metallic) mallet.



If a mallet is necessary for installation, we recommend placing the nut on the screw (loosely) before hammering to avoid damaging the bolt threads.



3. Make sure that the bolts are firm in place, yet let them stick out of the wall approximately 1 inch or less—enough that the wall bracket can be installed onto them. Firmly tighten the bolts with a 0.75" (19mm) hex key. It is best to use the hex key with a closed end rather than an open end to avoid damaging the nut, should it slip.

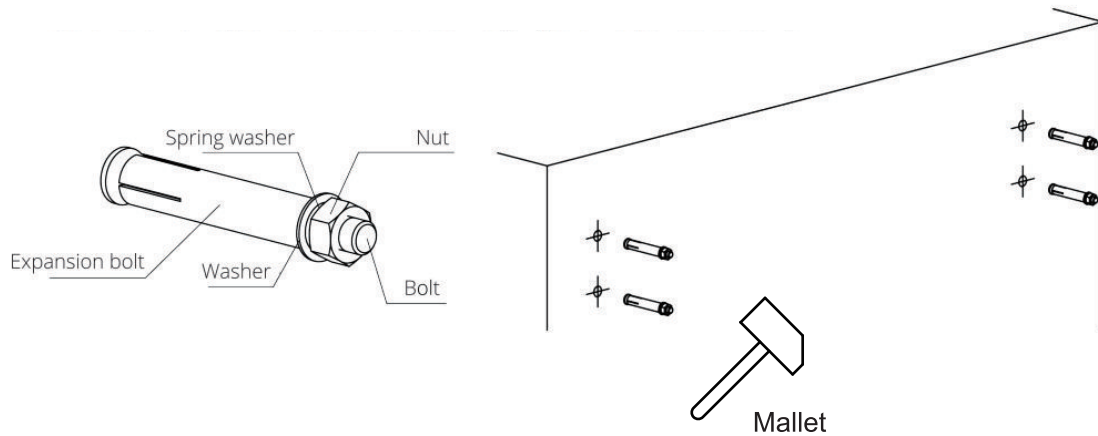

## STEP 4

### Mounting the Wall Brackets

1. Now that the bolts are securely installed in the wall, remove the nuts that are loosely placed over the bolts.
2. Place a wall bracket onto one set of bolts. This should be an easy fit if the bolt holes are properly aligned.
3. Once the wall bracket is resting on the bolts, place a washer over the bolt. Then secure it with a nut, as shown in the diagram.

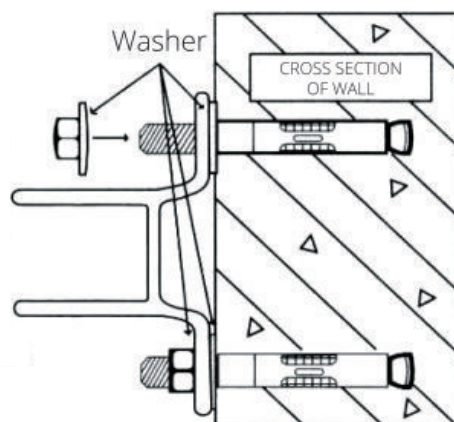

4. The brackets **MUST** sit firmly on the wall. If there is any movement, you must tighten it more.
5. Repeat this step for each of the wall brackets. Once you do this, all wall brackets will be securely installed in place.



## STEP5

### Mounting the Awning

1. Now that the wall brackets are secure and in place, it is time to install the awning onto the brackets.
2. At least two ladders or sturdy chairs are required to install the awning.
3. Put the torsion bars on the wall brackets and tighten them with the hex screws.
4. Finally, fasten all expansion bolts.
5. Using the hand crank or a motor (if applicable), fully open your awning. The front bar should be level.
6. Congratulations! Your awning is installed. If you are happy with the height of the front bar (awning pitch), sit back and enjoy! If not, please read on.

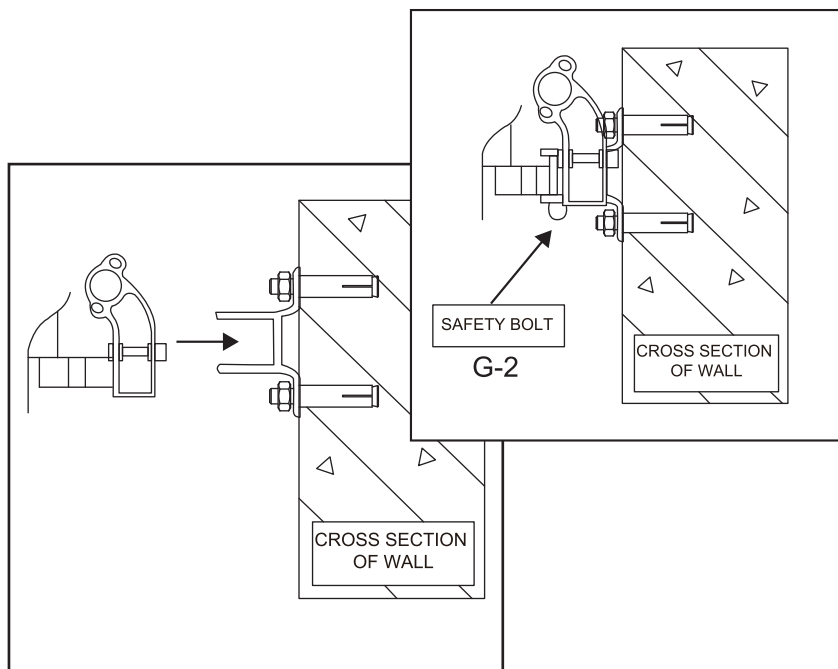

## OPTIONAL INSTALLATION

### Adjusting the Awning

Each awning comes with a pre-set pitch/angle that is considered ideal. However, if you need to make an adjustment, it can be done in just a few easy steps.

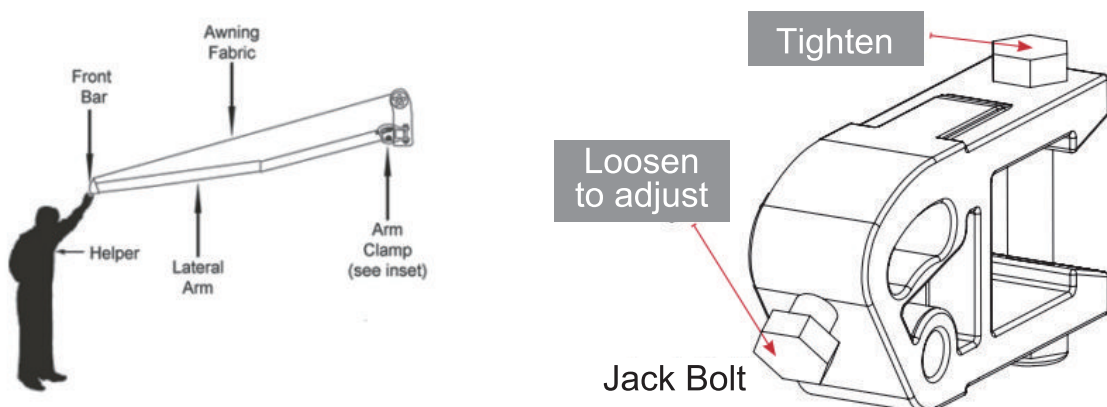

## ⚠ WARNING

Raising the front bar will reduce the pitch/angle of the fabric, thus increasing the risk of rain water pooling on the fabric. To prevent the awning from collapsing due to rain water weight, you must retract the awning when unattended. Failure to do so could result in a broken awning or personal injury.

**Note: Be sure that the front bar is adjust to be completely even. Any misalignment will result in improper retraction.**

## COMMON MISTAKES

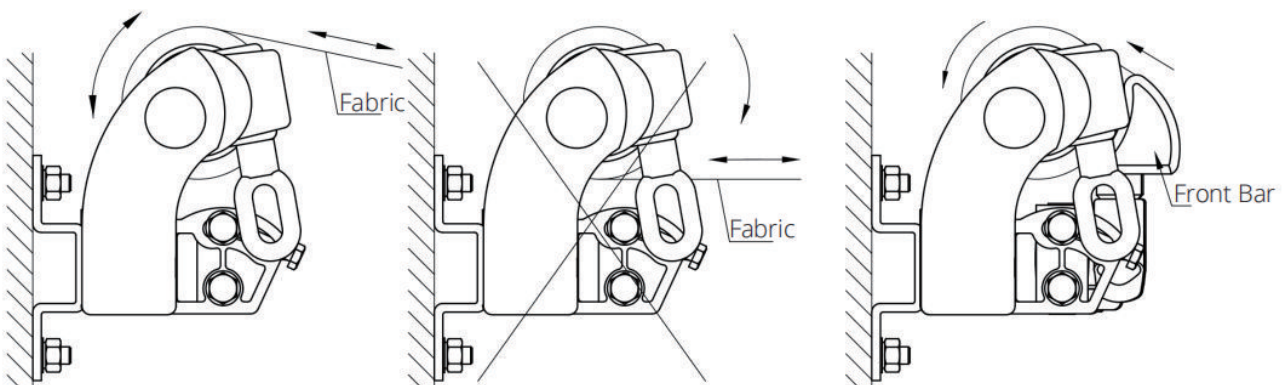

Correct operation

Wrong operation

## ⚠ WARNING

When the front bar touches the roller as shown in the figure, don't try to make them closer, otherwise the product may be damaged.