

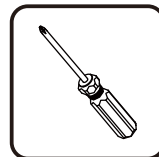

INboc021V01_GL

840-232

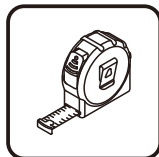

IMPORTANT, RETAIN FOR FUTURE REFERENCE: READ CAREFULLY

Tools Recommended

ASSEMBLY & INSTRUCTION MANUAL

PARTS

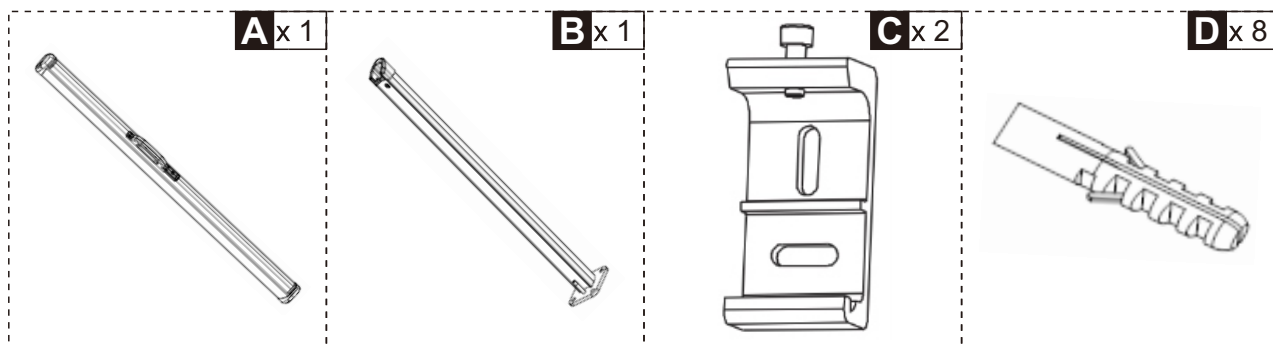

HARDWARE

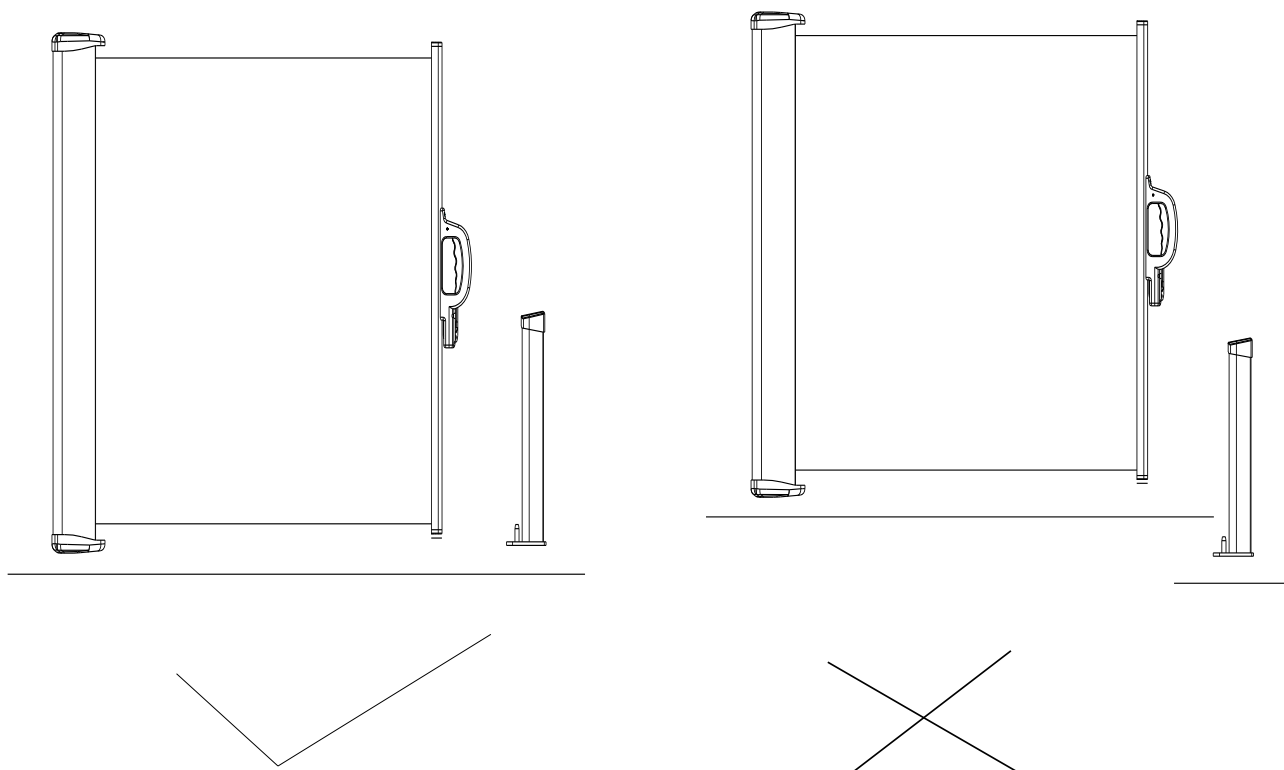
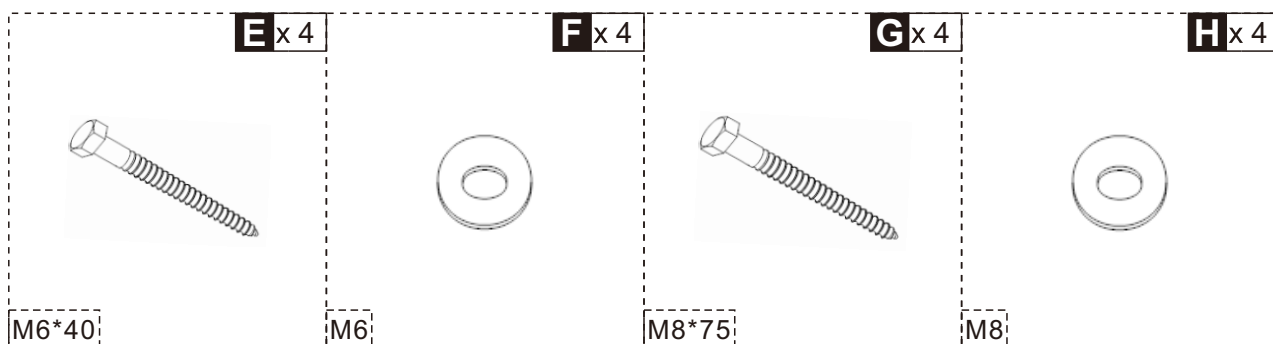

Warning: When mounting the awning, keep the cassette part and stand column on the horizon, or the fabric will deformation and difficult to open and close.

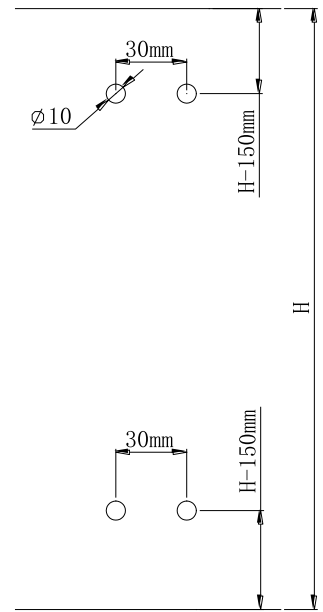
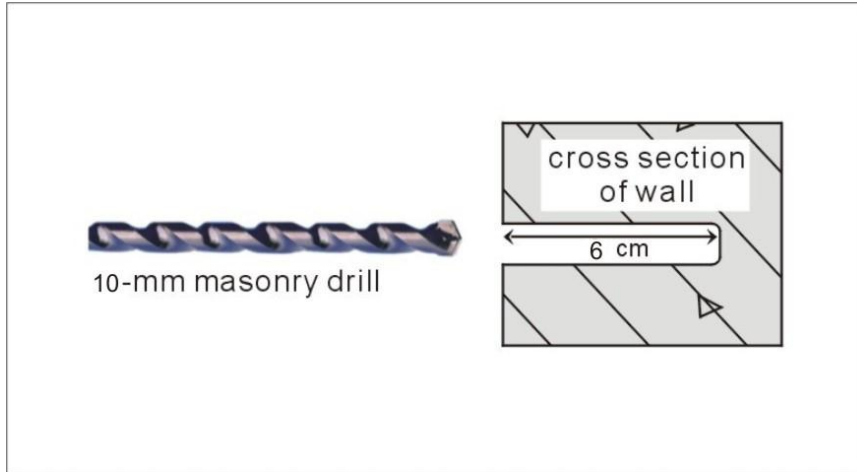

1. Drill 6cm deep holes in the size as the following picture shows

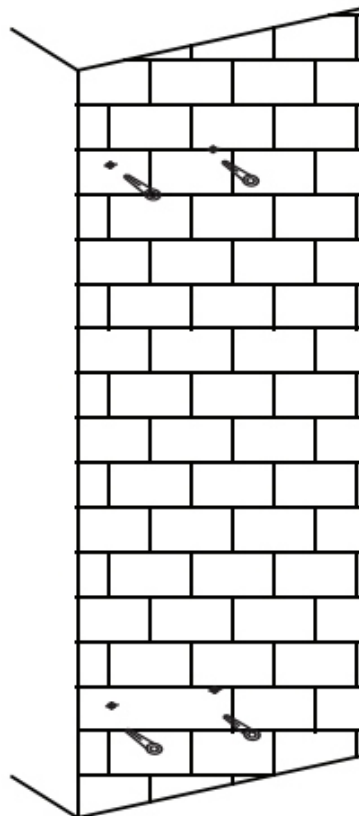

2. Insert one $\phi 10 \times 50$ mm plastic expansion tube in each of holes.

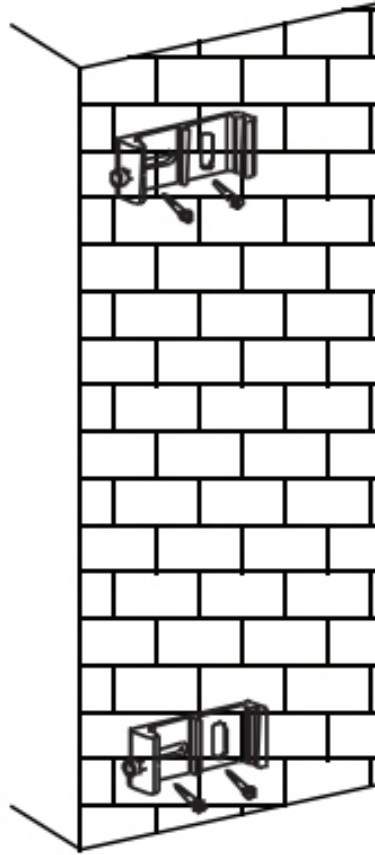

3. Fix the bracket with M6x60 hexagon tapping bolt

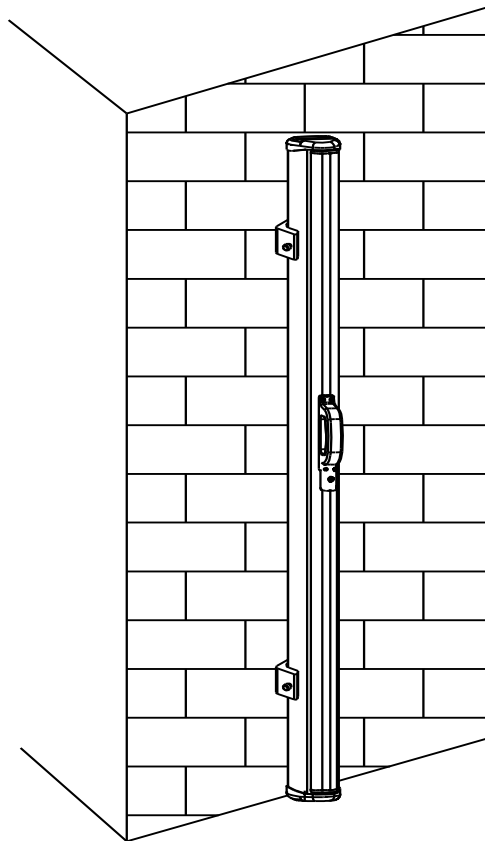

4. Insert the cassette part into the bracket, tighten the flat fillister head screw M6x16mm with Hexagonal spanner CR-V5mm

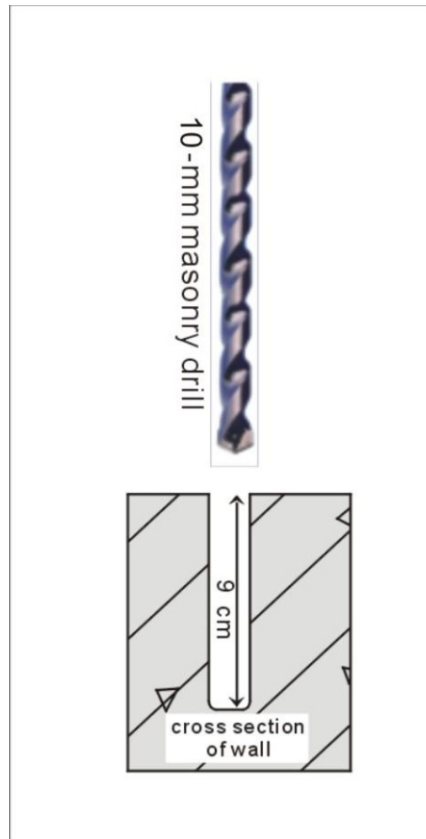

5. Drill four 10mm diameter holes on the floor in the size as the following picture shows

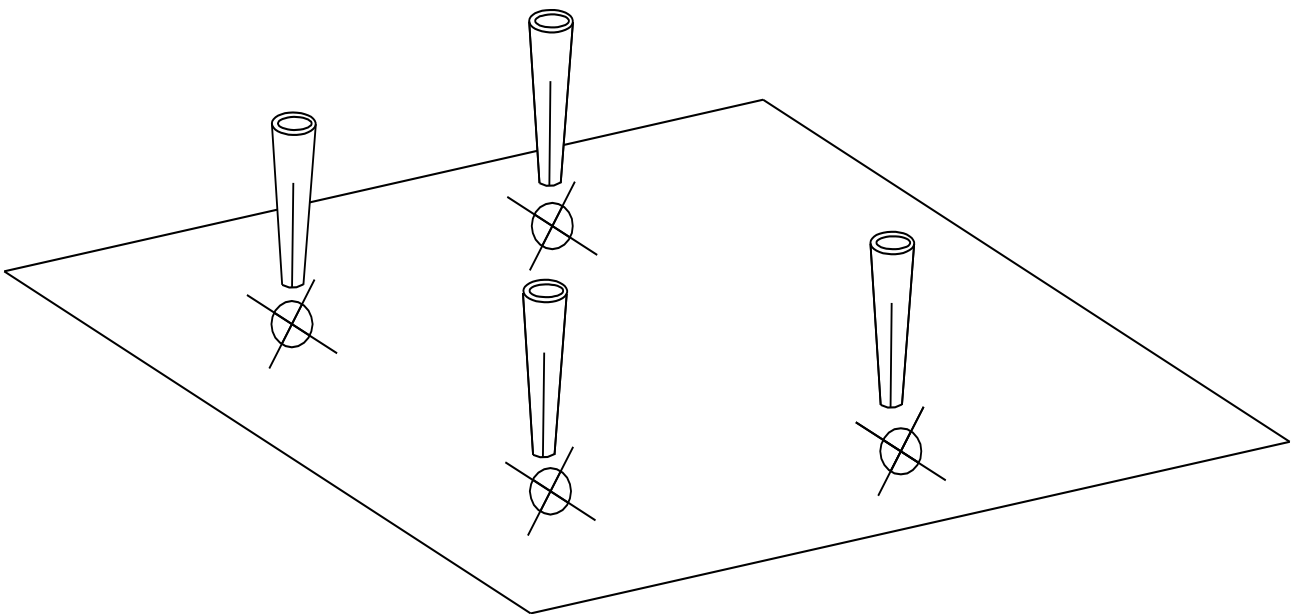

6. sert one $\phi 10 \times 50$ mm plastic expansion tube (4pcs) in each of holes

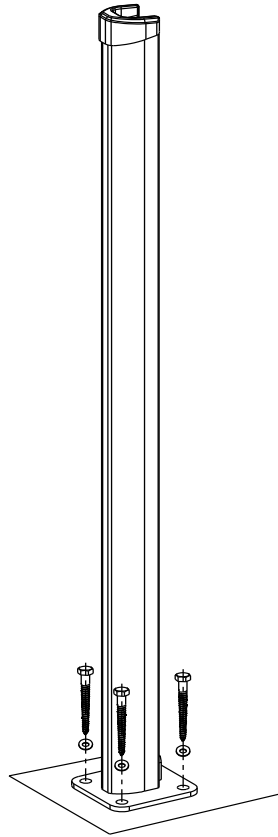

7. Make the left bottom hole of stand column and the hole on the floor alignment, and tighten them with M8x75 hexagon tapping bolt.

CORRECT USE

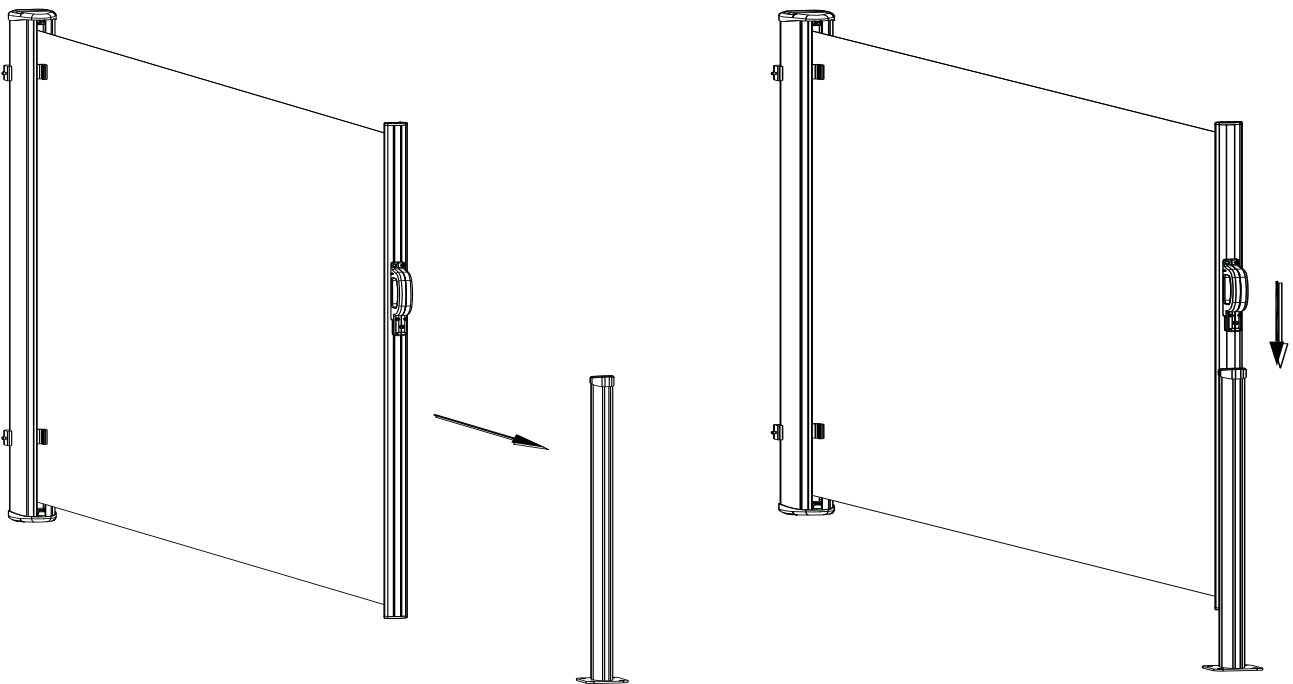

1. Keep the front bar upright, hold the handle and pull it over the column. Hold the handle tightly, rotate it 90 degrees, align the side of the front rod with the groove of the column and put it in, so that the main shaft of the handle can be clamped into the groove. See the figure below for details

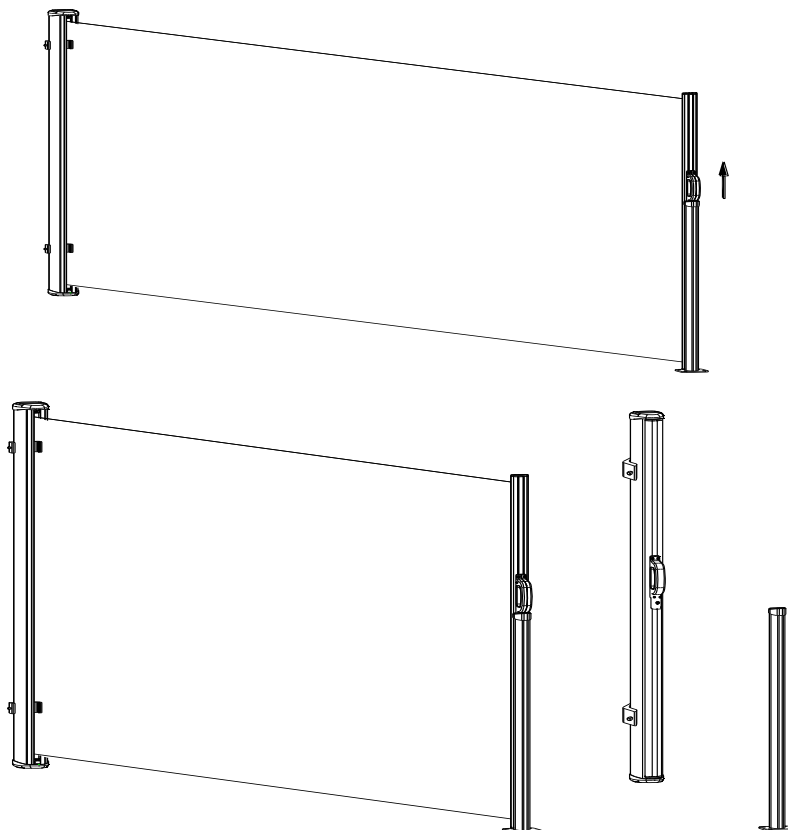
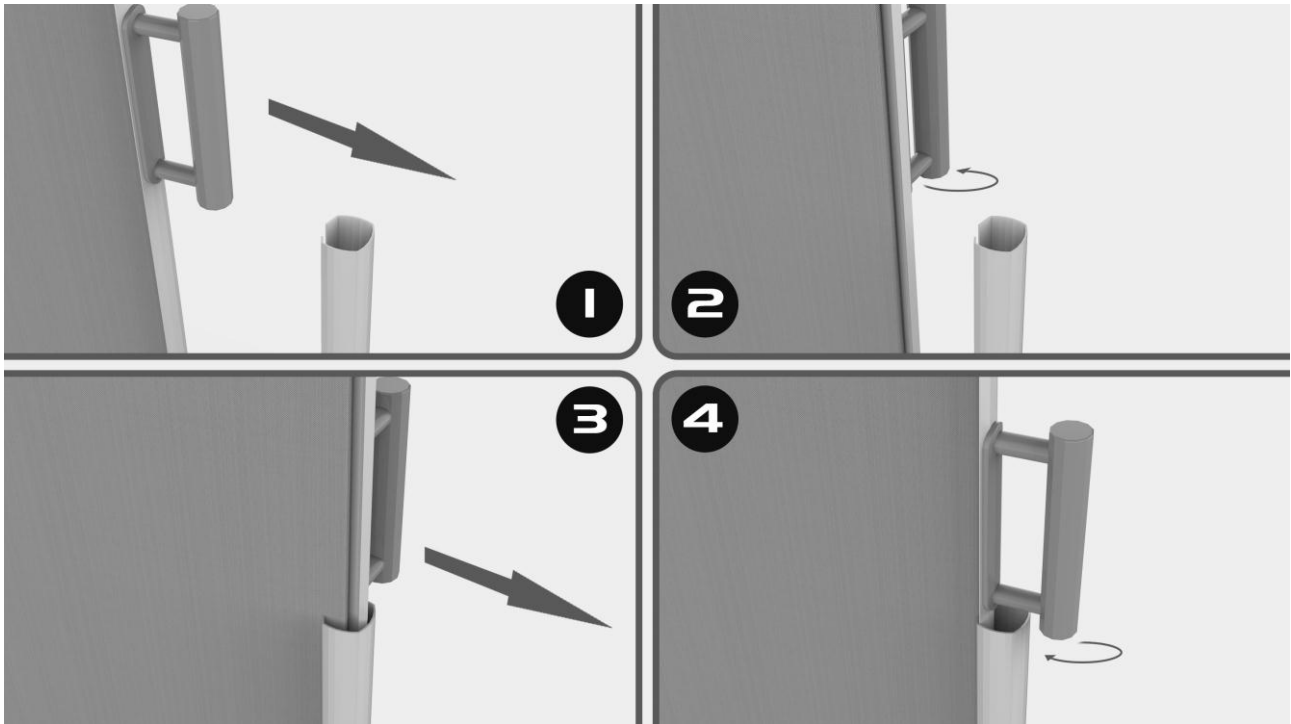

2. Before closing, pull it out first, then rotate it 90 degrees to make the side of side bar align with the groove, and then close it slowly