

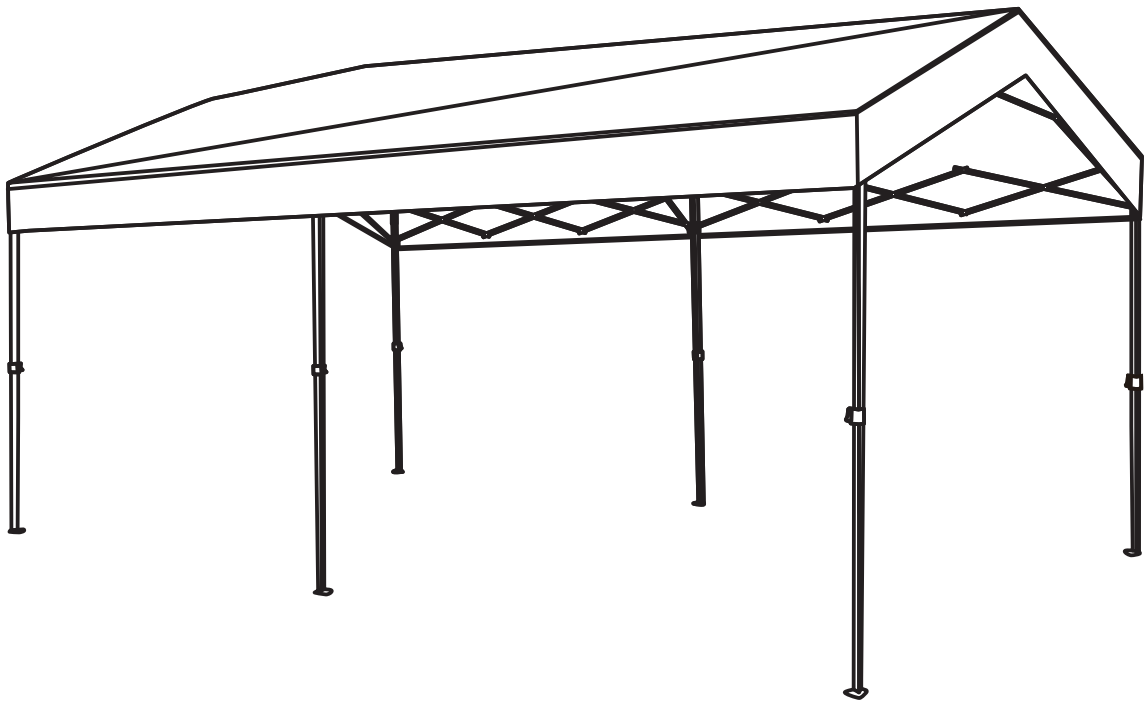

INbra002_IT

84C-251



READ AND SAVE THIS INSTRUCTIONS FOR FUTURE USE

ASSEMBLY & INSTRUCTION MANUAL

Avvertenze:

1. Questa tenda va assemblata da 3 persone.
2. Si prega di maneggiare nel modo corretto poiche' forti piogge, vento e neve potrebbero danneggiare la tenda. Se necessario, smontare e conservare per un uso futuro.
3. In condizioni di neve si prega di non lasciare che lo spessore della neve superi i 5 cm sul tetto, e invece rimuovere la neve il prima possibile per la vostra sicurezza.

① x 1

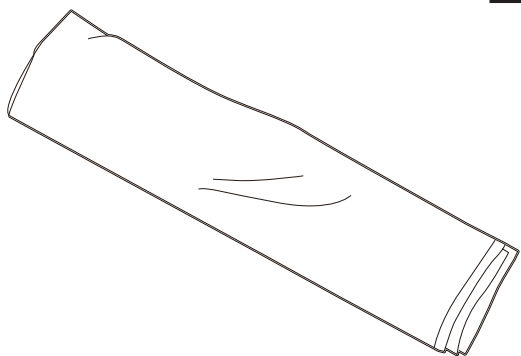

② x 1

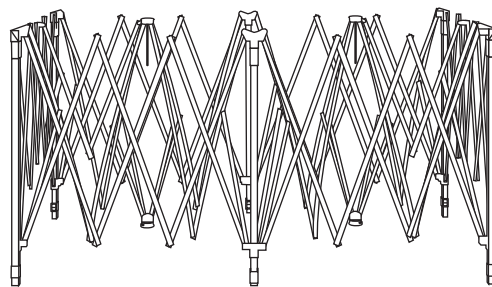

③ x 1

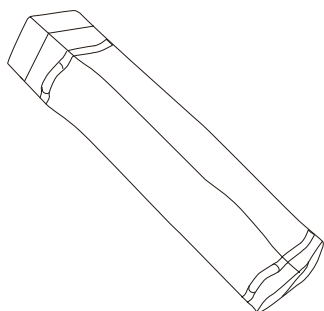

④ x 16

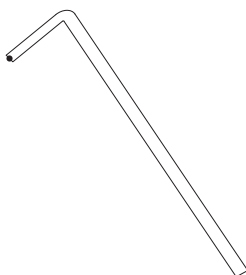

⑤ x 4

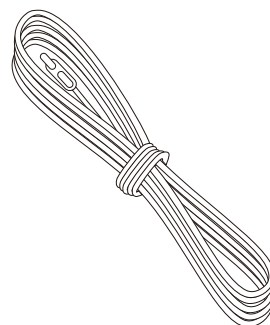

01

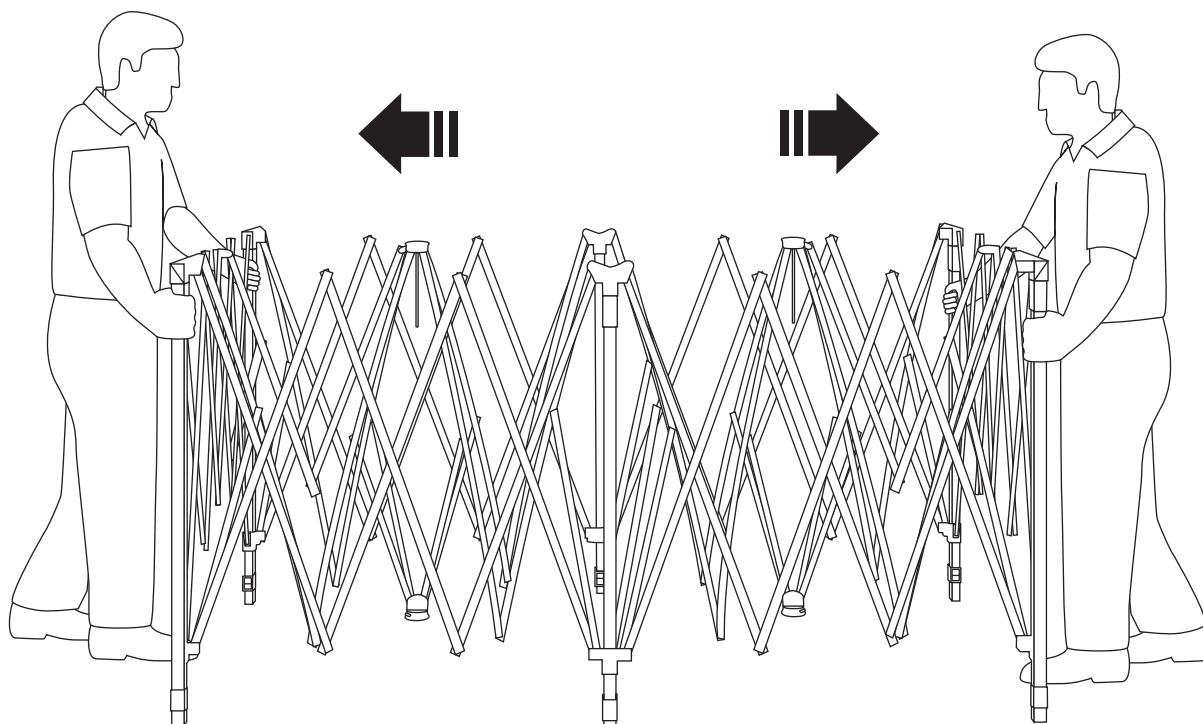

1. Con due persone sulle estremità diagonali, sollevare e separare parzialmente il telaio del tettuccio.

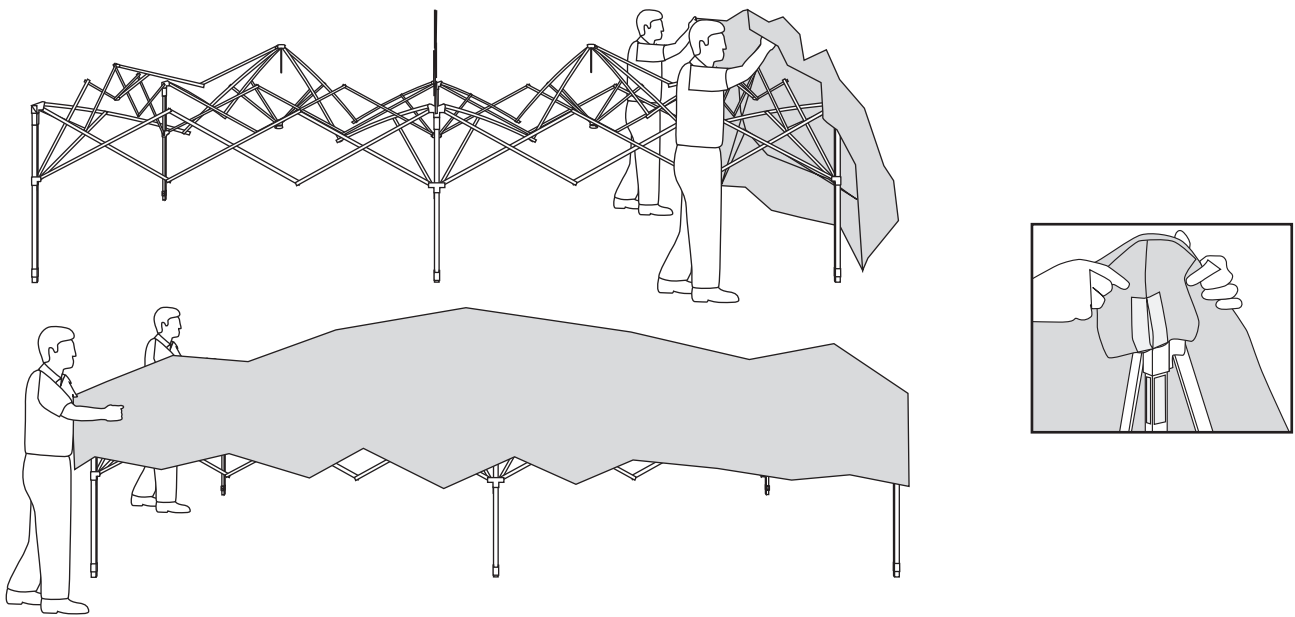

2. Aprire la grande parte superiore del tettuccio e posizionarla sul telaio aperto. Attaccare i quattro angoli del baldacchino all'angolo superiore del tubo della gamba.

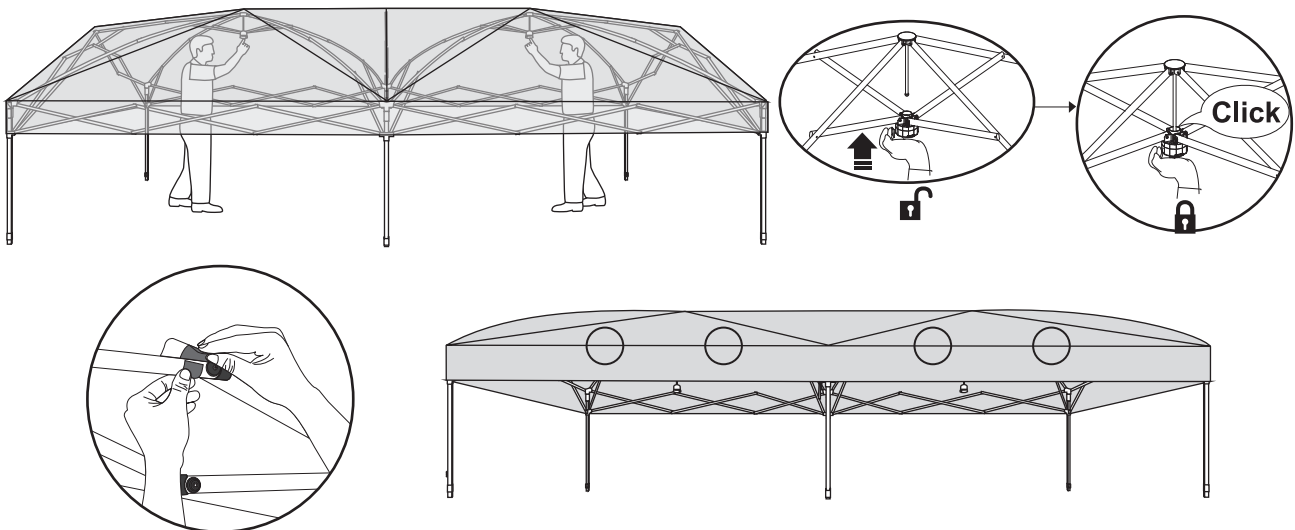

3. Sotto il tettuccio, posizionare una mano sul telaio superiore e utilizzare l'altra mano per spingere il mozzo centrale verso l'alto finché non scatta nel palo centrale. Finisci di attaccare il grande baldacchino all'interno del telaio del baldacchino usando gli anelli in velcro.

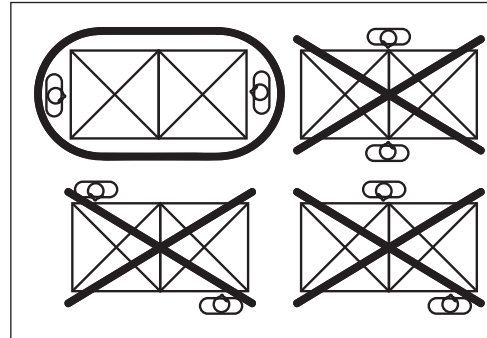
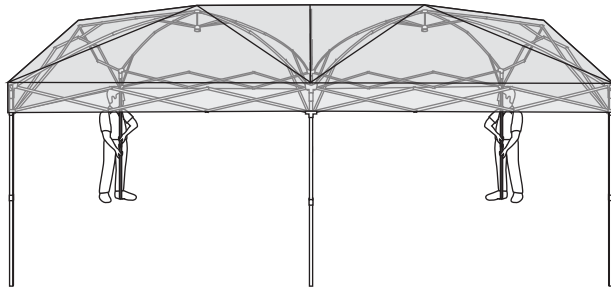
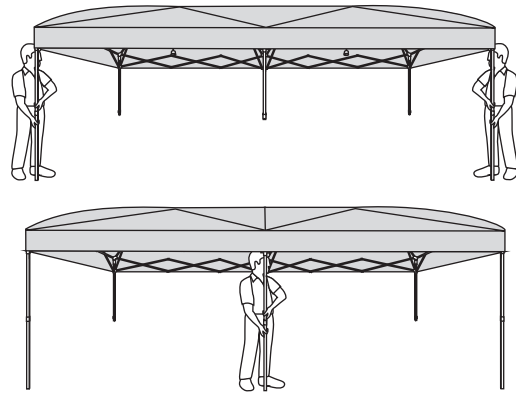
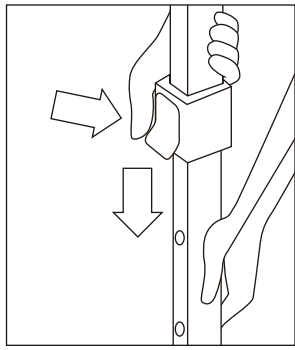

4. Premere il pulsante rosso su ciascuna gamba e sollevare o abbassare per regolare l'altezza della vela.

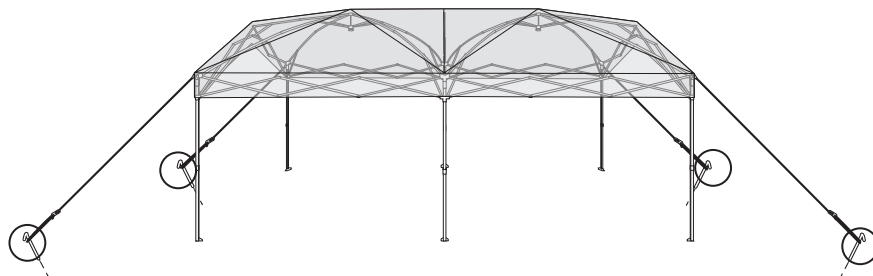
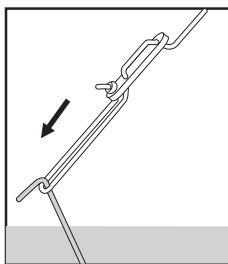
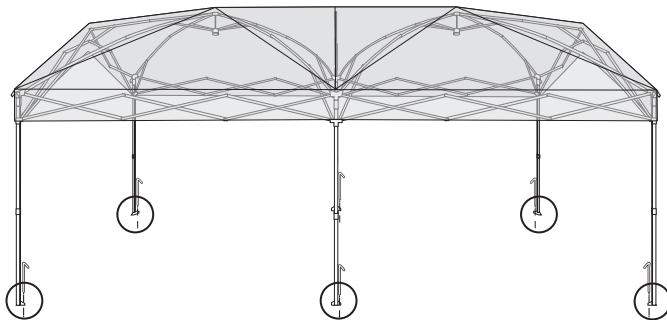
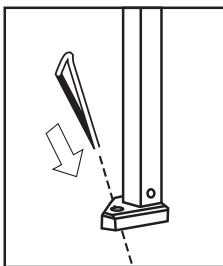

5. Fissare le funi agli anelli di plastica sulla tenda da sole e legare le funi ai picchetti nel terreno. Assicurarsi che le funi abbiano la tensione corretta regolando i regolatori di plastica sulle funi.

Done

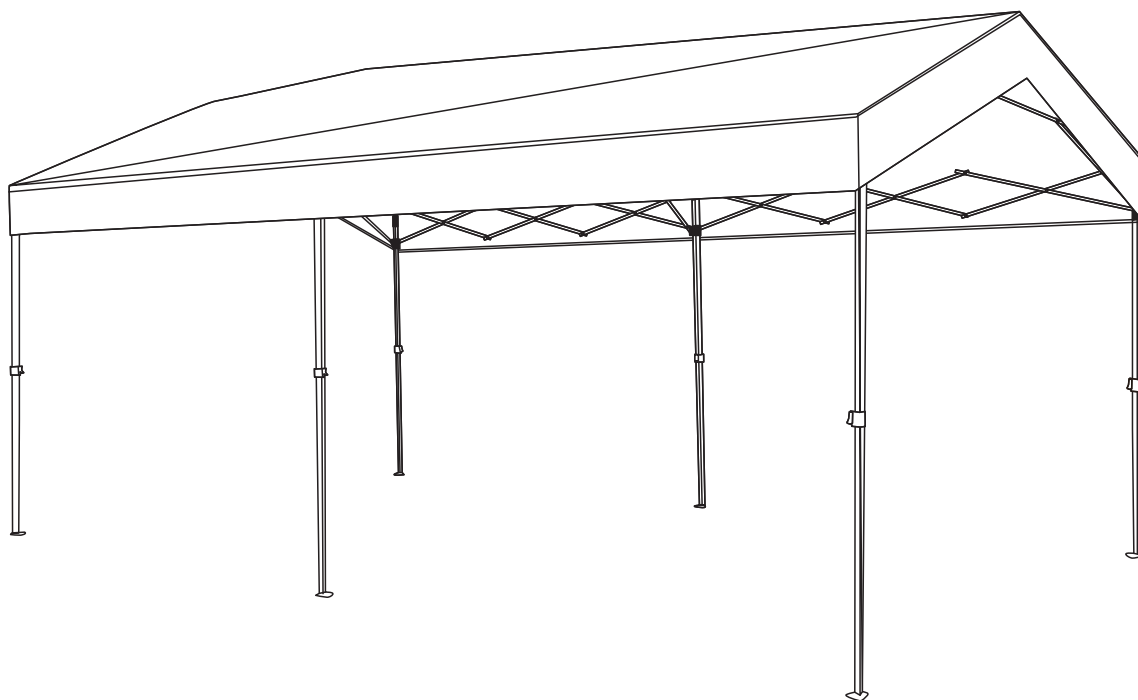

After Each Use

01

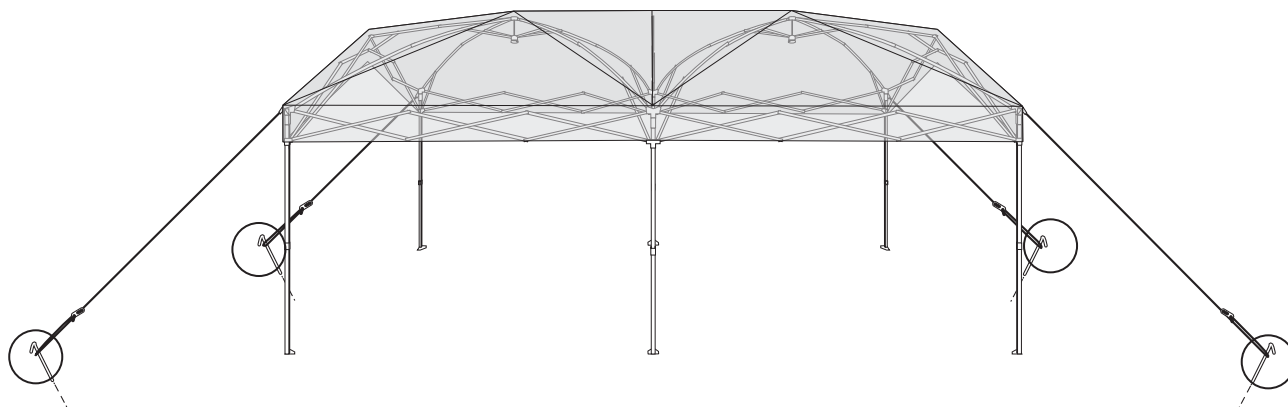
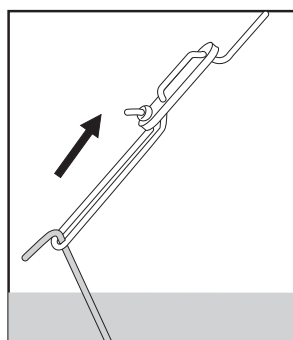
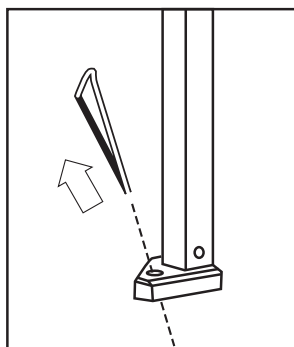

1. Liberare le funi dagli anelli di plastica. Sollevare tutti i picchetti da terra.

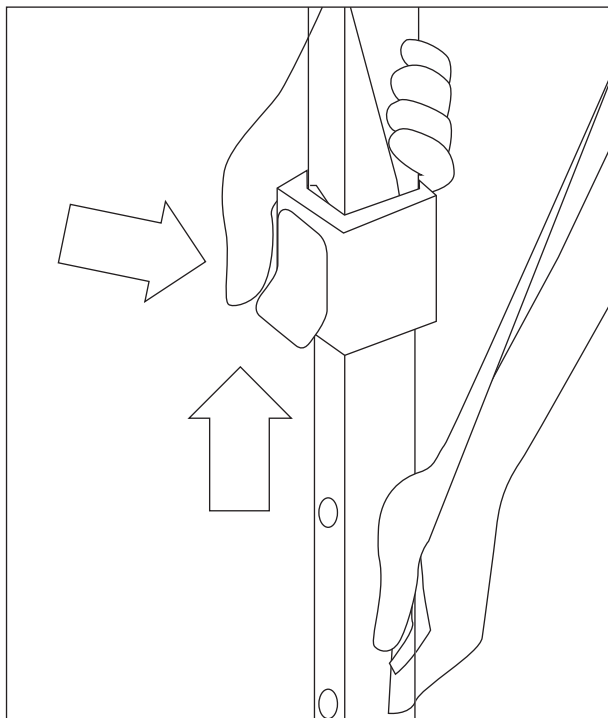

2. Premere il pulsante rosso su ciascuna gamba e ritrarre le gambe alla loro altezza originale.

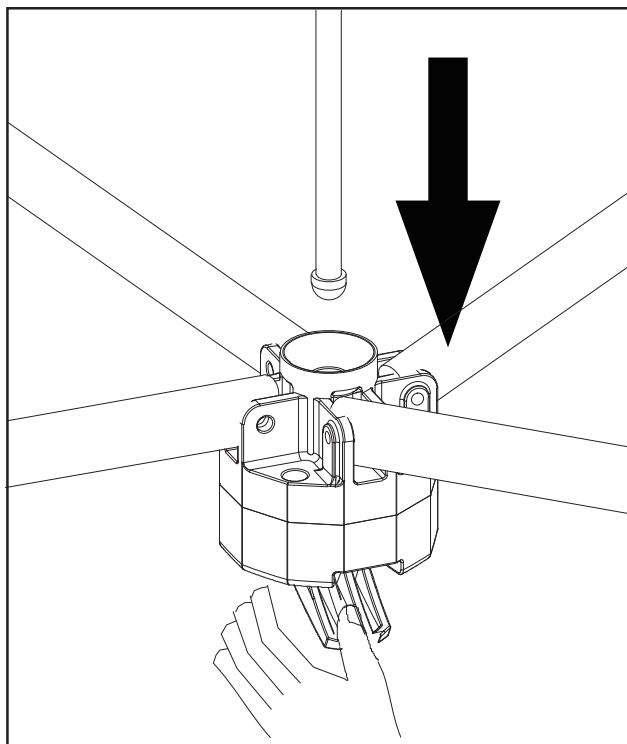

3. Entra nella parte inferiore del tettuccio, ruota in senso antiorario il mozzo inferiore centrale per sbloccare il telaio.

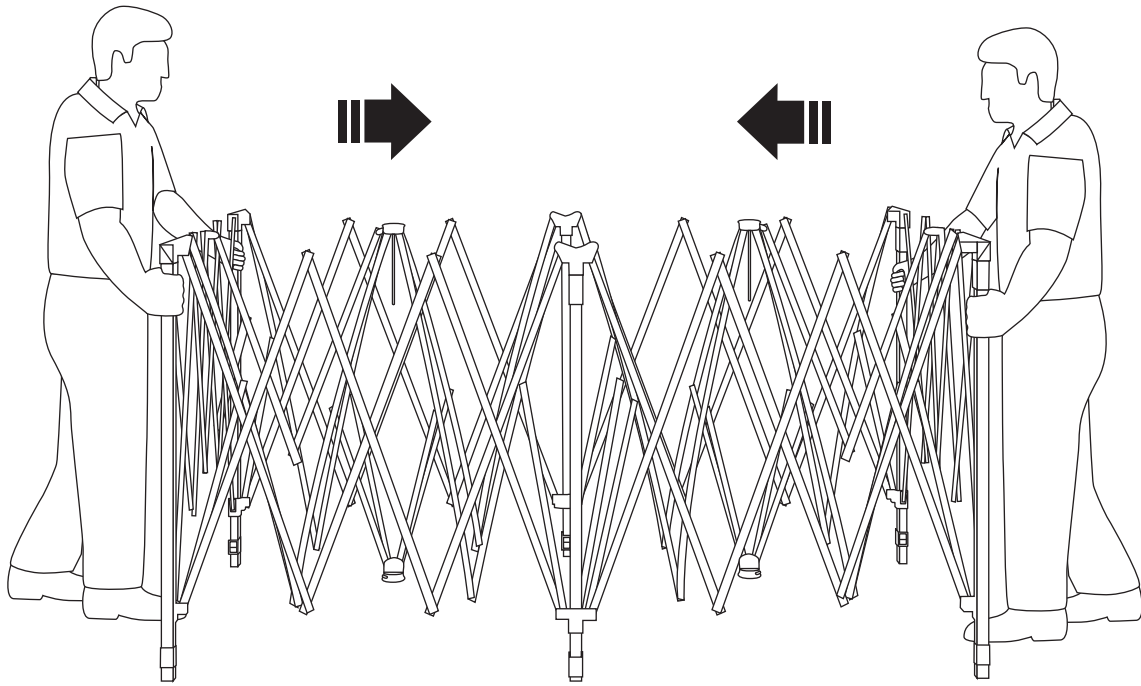

4. Sollevare un angolo del telaio finché tutte le gambe non sono sollevate da terra tranne la gamba 1 sull'angolo opposto. Spingere verso l'interno fino a quando il telaio è completamente chiuso.

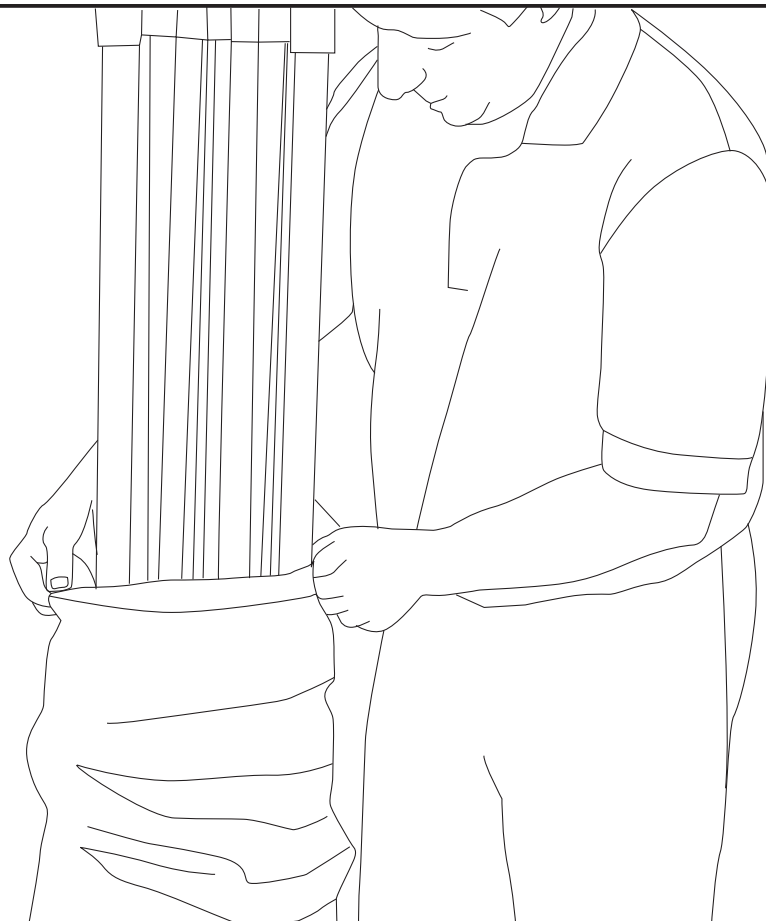

5. Con i piedi del tettuccio rivolti verso i rulli, far scorrere la borsa portaoggetti con ruote sul telaio del tettuccio chiuso.

US



001-877-644-9366
customerservice@aosom.com

CA



001-855-537-6088
customerservice@aosom.ca

UK



0044-800-240-4004
enquiries@mhstar.co.uk

DE



0049-(0)40-88307530
service@aosom.de

FR



0033-1-84166106
contact@aosom.fr

ES



0034-931294512
atencioncliente@aosom.es

IT



0039-0249471447
clienti@aosom.it