

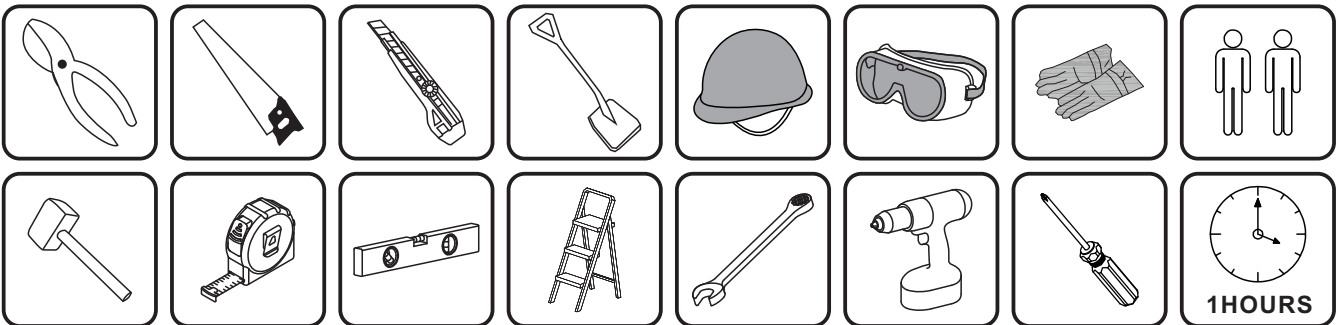

INbxa001\_GL

845-391

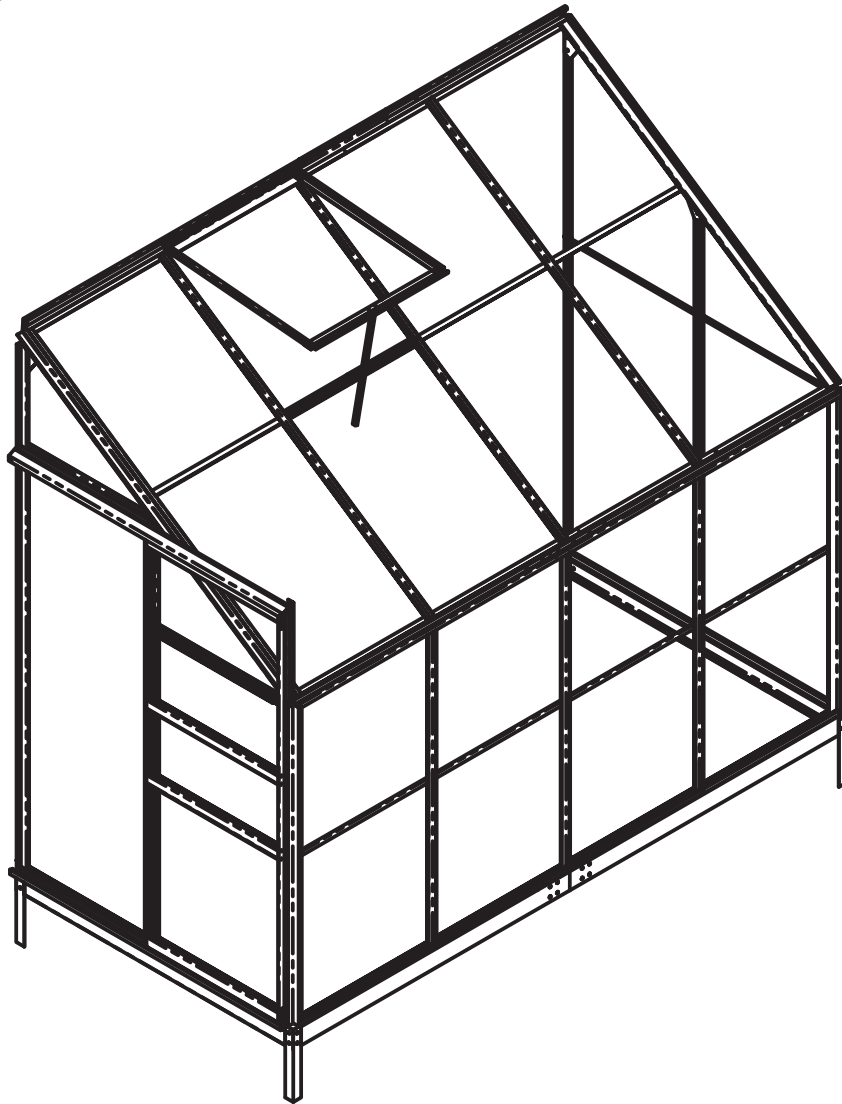

READ AND SAVE THIS INSTRUCTIONS FOR FUTURE USE

Tools Recommended

# ASSEMBLY & INSTRUCTION MANUAL

## **TO PREVENT INJURY, READ AND UNDERSTAND THE GREENHOUSE ASSEMBLY INSTRUCTIONS BEFORE USE.**

### **Notes:**

1. It takes about 1-2 hours to assemble the greenhouse by 2-3 persons.
2. The UV-protected side of the sheet is covered with opal white film and must face towards the sun.
3. Remove approximately 2 inches of film from all sheet edges before installing. Removing all film immediately after the construction is completed
4. Make sure the greenhouse is located on a flat, level surface.

## **GENERAL SAFETY, WARNINGS AND PRECAUTIONS**

### **KEEP WORK AREA CLEAN AND DRY.**

Cluttered, damp or wet work areas invite injuries.

**STAY ALERT.** Watch what you are doing at all times. Use common sense. Do not use the greenhouse when you are tired or distracted from the job at hand. It is recommended to use gloves for assembling the greenhouse.

### **MAINTAIN THIS PRODUCT WITH CARE.**

Keep the greenhouse clean and dry for better performance: maintenance should be performed regularly.

### **USE THE RIGHT PRODUCT FOR THE JOB.**

Do not attempt to force a small product to do the work of a larger industrial product. There are certain applications for which the greenhouse was designed. It will do the job better and more safely in the manner for which it was intended. Do not modify the greenhouse and do not use the greenhouse for a purpose for which it was not intended.

### **MAINTAIN A SAFE WORKING ENVIRONMENT.**

Keep the work area tidy. Make sure there is adequate surrounding workspace. Avoid high traffic areas. Always keep the work area free of obstructions, grease, oil, trash and other debris.

### **PROPER GREENHOUSE LOCATION.**

Make sure the greenhouse is located on a flat, level surface.

**POUR ÉVITER LES RISQUES DE BLESSURES VEILLENZ LIRE ET COMPRENDRE LES INSTRUCTIONS DE MONTAGE DE LA SERRE AVANT DE L'UTILISER.**

**Notes:**

1. Il faut environ 1 à 2 heures pour assembler la serre par 2 à 3 personnes.
2. La face de la feuille protégée contre les UV est recouverte d'un film blanc opale et doit être orientée vers le soleil.
3. Enlevez environ 2 pouces de film sur tous les bords de la feuille avant l'installation. Enlever tous les films immédiatement après la fin des travaux
4. Assurez-vous que la serre est située sur une surface plane et horizontale.

**SÉCURITÉ GÉNÉRALE, AVERTISSEMENTS ET PRÉCAUTIONS**

**GARDER LA ZONE DE TRAVAIL PROPRE ET SÈCHE.**

Les zones de travail encombrées, humides ou mouillées sont propices aux blessures.

RESTEZ VIGILANT. Surveillez ce que vous faites à tout moment. Faites preuve de bon sens. N'utilisez pas la serre lorsque vous êtes fatigué ou distrait du travail en cours. Il est recommandé d'utiliser des gants pour le montage de la serre.

**ENTRETIENEZ CE PRODUIT AVEC SOIN.**

Gardez la serre propre et sèche pour un meilleur rendement : l'entretien doit être effectué régulièrement.

**UTILISEZ LE PRODUIT APPROPRIÉ POUR LE TRAVAIL À EFFECTUER.**

N'essayez pas de forcer un petit produit à faire le travail d'un produit industriel plus important. La serre a été conçue pour certaines applications. Elle fera mieux le travail pour lequel elle a été conçue et de manière plus sûre. Ne modifiez pas la serre et n'utilisez pas la serre à des fins pour lesquelles elle n'a pas été conçue.

**MAINTENIR UN ENVIRONNEMENT DE TRAVAIL SÛR.**

Maintenez l'espace de travail en ordre. Assurez-vous que l'espace de travail environnant est adéquat. Évitez les zones à forte circulation. Maintenez la zone de travail toujours libre de tout obstacle, graisse, huile, déchets et autres débris.

**EMPLACEMENT ADÉQUAT DE LA SERRE.**

Veillez à ce que la serre soit située sur une surface plane et de niveau.

**PARA PREVENIR LESIONES, LEA Y COMPRENDA LAS INSTRUCCIONES DE MONTAJE DEL INVERNADERO ANTES DE USARLO.**

**Notas:**

1. Se requiere 1 y 2 horas para montar el invernadero por 2 y 3 personas.
2. El lado de la hoja protegido contra los rayos UV está cubierto con una película de color blanco opal y debe mirar hacia el sol.
3. Retire aproximadamente 2 pulgadas de película de todos los bordes de la hoja antes de instalar. Retire toda la película inmediatamente después de que se complete la instalación.
4. Asegúrese de que el invernadero esté ubicado en una superficie plana y nivelada.

**SEGURIDAD GENERAL, ADVERTENCIAS Y PRECAUCIONES**

**MANTENGA EL ÁREA DE TRABAJO LIMPIA Y SECA.**

Las áreas de trabajo desordenadas, húmedas o mojadas pueden provocar lesiones.

**MANTÉNGASE ALERTA.** Vigile lo que está haciendo en todo momento con el conocimiento común. No use el invernadero cuando esté cansado o distraído del trabajo en cuestión. Se recomienda utilizar guantes para montar el invernadero.

**MANTENGA ESTE PRODUCTO CON CUIDADO.**

Mantenga el invernadero limpio y seco para un mejor rendimiento: el mantenimiento debe realizarse con regularidad.

**USE EL PRODUCTO ADECUADO PARA EL TRABAJO.**

No intente forzar a un producto pequeño a hacer el trabajo que debe hacerse por un producto industrial más grande. Existen determinadas aplicaciones para las que se ha diseñado el invernadero. Puede hacer el trabajo mejor y con más seguridad si se usa en la manera para la que fue diseñado. No modifique el invernadero y no lo utilice para fines para los que no fue diseñado.

**MANTENGA UN AMBIENTE DE TRABAJO SEGURO.**

Mantenga el área de trabajo ordenada. Asegúrese de que haya un espacio de trabajo circundante adecuado. No lo use en las áreas de mucho tráfico. Mantenga siempre el área de trabajo libre de obstrucciones, grasa, aceite, basura y otros desechos.

**UBICACIÓN APROPIADA DEL INVERNADERO.**

Asegúrese de que el invernadero esté ubicado en una superficie plana y nivelada.

**Um Verletzungen zu vermeiden, lesen und verstehen Sie bitte vor dem Gebrauch die Anweisungen zur Montage des Gewächshauses.**

**Hinweise:**

1. Es dauert ungefähr 1-2 Stunden, um das Gewächshaus von 2-3 Personen zusammenzubauen.
2. Die UV-geschützte Seite des Blattes ist mit opalweißem Film bedeckt und muss der Sonne zugewandt sein.
3. Entfernen Sie vor der Installation ca. 2 Zoll Film von allen Blattkanten. Entfernen Sie den gesamten Film sofort nach Abschluss des Baus
4. Stellen Sie sicher, dass sich das Gewächshaus auf einer ebenen Fläche befindet.

**Allgemeine Sicherheit, Warnhinweise und Vorsichtsmaßnahmen**

**Halten Sie Arbeitsbereich sauber und trocken .**

Überfüllte, feuchte oder nasse Arbeitsbereiche können zu Verletzungen führen.

WACHSAM BLEIBEN. Beobachten Sie jederzeit, was Sie tun. Verwenden Sie gesunden Menschenverstand. Verwenden Sie das Gewächshaus nicht, wenn Sie müde oder von der anstehenden Aufgabe abgelenkt sind. Es wird empfohlen, für die Montage des Gewächshauses Handschuhe zu tragen.

**Behalten Sie dieses Produkt mit Pflege**

Halten Sie das Gewächshaus sauber und trocken, um eine bessere Leistung zu erzielen: Regelmäßige Wartungsarbeiten sollten durchgeführt werden.

**Verwenden Sie das richtige Produkt für den Job**

Versuchen Sie nicht, ein kleines Produkt zu zwingen, die Arbeit eines größeren Industrieprodukts zu erledigen. Es gibt bestimmte Anwendungen, für die das Gewächshaus konzipiert wurde. Es wird die Arbeit besser und sicherer in der Weise erledigen, für die es bestimmt war. Ändern Sie das Gewächshaus nicht und verwenden Sie es nicht für Zwecke, für die es nicht vorgesehen war.

**Sorgen Sie für ein sicheres Arbeitsumfeld.**

Halten Sie den Arbeitsbereich sauber und ordentlich. Stellen Sie sicher, dass Sie genügend Arbeitsfläche um sich haben. Vermeiden Sie stark frequentierte Bereiche. Halten Sie den Arbeitsbereich immer frei von Hindernissen, Fett, Öl, Müll und anderen Fremdkörpern.

**Richtige Gewächshauslage.**

Stellen Sie sicher, dass sich das Gewächshaus auf einer ebenen Fläche befindet.

**PER PREVENIRE LESIONI, LEGGETE E COMPRENDETE LE ISTRUZIONI DI ASSEMBLAGGIO DELLA SERRA PRIMA DELL'USO.**

**NOTA:**

1. Ci vogliono circa 1-2 ore per assemblare la serra con 2-3 persone.
2. Il lato protetto dai raggi UV del foglio ricoperto da una pellicola bianca opalina deve essere rivolto verso il sole.
3. Togli circa 2 pollici di pellicola da tutti i bordi del foglio prima dell'installazione. Togli tutta la pellicola immediatamente dopo il completamento della costruzione.
4. Assicurati che la serra si trovi su una superficie piana e livellata.

**SICUREZZA GENERALE, AVVERTENZE E PRECAUZIONI**

**MANTENETE L'AREA DI LAVORO PULITA E ASCIUTTA.**

Le aree di lavoro disordinate, umide o bagnate potrebbero provocare lesioni.

**STAI ATTENTO.** Stai attento su cosa stai facendo in ogni momento. Usa il senso comune e non usare la serra quando sei stanco o distratto nel lavoro da svolgere. Si consiglia di utilizzare i guanti per l'assemblaggio della serra.

**MANTENETE QUESTO PRODOTTO CON CURA.**

Mantieni la serra pulita e asciutta per prestazioni migliori: la manutenzione deve essere eseguita regolarmente.

**UTILIZZATE IL PRODOTTO GIUSTO PER IL LAVORO.**

Non tentare di forzare un prodotto piccolo a svolgere un lavoro di un prodotto industriale più grande. Ci sono alcune applicazioni per le quali il prodotto è stato progettato. Il prodotto funzionerà meglio e più sicuro nel modo per cui è stato progettato. Non modificare la serra e non utilizzare la serra per scopi per i quali non è stata concepita.

**MANTENETE UN AMBIENTE DI LAVORO SICURO.**

Tieni in ordine l'area di lavoro. Assicurati che ci sia uno spazio di lavoro circostante adeguato. Evita le zone di molto traffico. Mantieni sempre l'area di lavoro libera da ostruzioni, grasso, olio, rifiuti e altri detriti.

**POSIZIONE ADEGUATA DELLA SERRA.**

Assicurati che la serra si trovi su una superficie piana e livellata.

## Notes:

1. Remove approximately 2 inches of film from all sheet edges before installing. remove all film immediately after the constructions completed.
2. The UV-protected side of the sheet is covered with opal white film and must face towards the sun.

## Notes:

1. Retirez environ 2 pouces de film de tous les bords de la feuille avant de l'installer. Retirez tout le film immédiatement à la fin des travaux.
2. La face de la feuille protégée contre les UV est recouverte d'un film blanc opale et doit être orientée vers le soleil.

## Notas:

1. Retire aproximadamente 2 pulgadas de película de todos los bordes de la hoja antes de instalar el producto. Retire toda la película inmediatamente después de completar la instalación.
2. El lado de la hoja protegido contra los rayos UV está cubierto con una película de color blanco ópalo y debe mirar hacia el sol.

## Anmerkungen:

1. Entfernen Sie vor der Installation ca. 2 Zoll Film von allen Blattkanten. Entfernen Sie den gesamten Film sofort nach Abschluss der Bauarbeiten.
2. Die UV-geschützte Seite des Blattes ist mit opalweißem Film bedeckt und muss der Sonne zugewandt sein.

## Nota:

1. Togli circa 2 pollici di pellicola da tutti i bordi del foglio prima dell'installazione. Togli tutta la pellicola immediatamente dopo aver completato le costruzioni.
2. Il lato protetto dai raggi UV del fogli, ricoperto da una pellicola bianca opalina, deve essere rivolto verso il sole.



## Rear/Arrière/Trasero/Rückseite/Retro

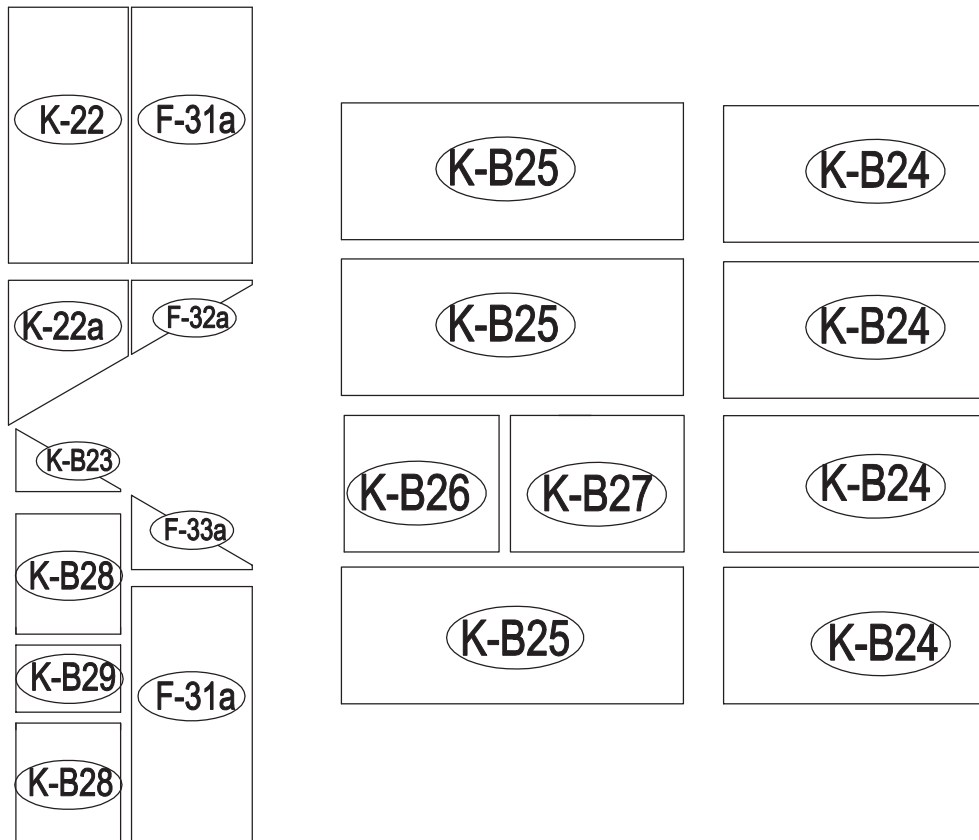

## Front/Devant/Delantero/Vorderseite/Fronte

### POLYCARBONATE PANEL

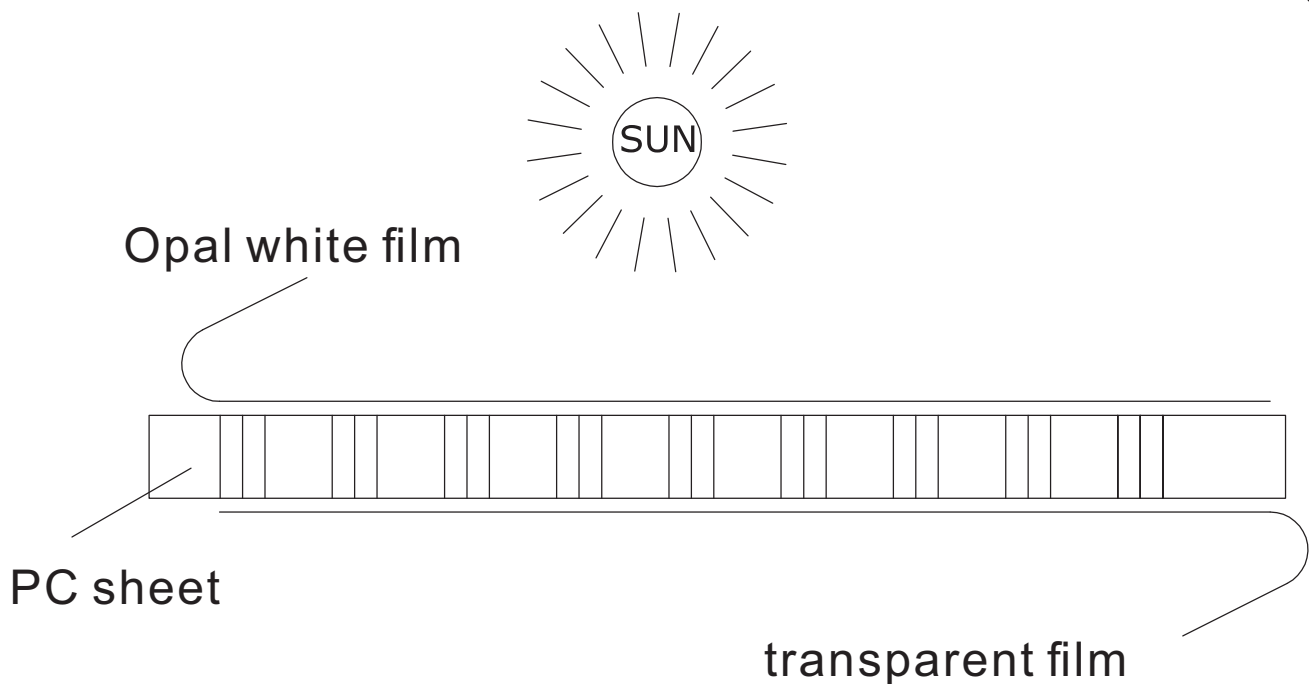

Two sides of PC sheet are covered with thin film, one side's film is transparent, another's film is opal white. The UV-protected side of the sheet is covered with opal white film and must face towards the sun.



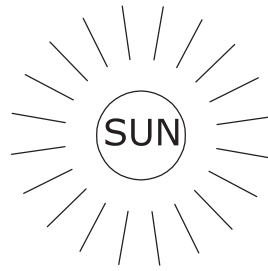

Film blanc opal

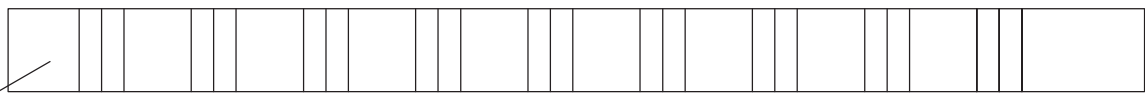

Feuille de PC

Film transparent

Les deux faces de la feuille de PC sont recouvertes d'un film fin, le film d'une face est transparent, celui de l'autre est blanc opale. La face de la feuille protégée contre les UV est celle recouverte d'un film blanc opale; elle doit être orientée vers le soleil.

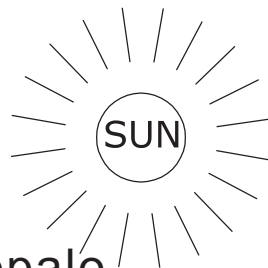

Película blanca ópalo



Lámina PC

Película transparente

Dos lados de la hoja de PC están cubiertos con una película delgada, la película de un lado es transparente y la película del otro es de color blanco ópalo. El lado de la hoja protegido contra los rayos UV está cubierto con una película de color blanco ópalo y debe mirar hacia el sol.

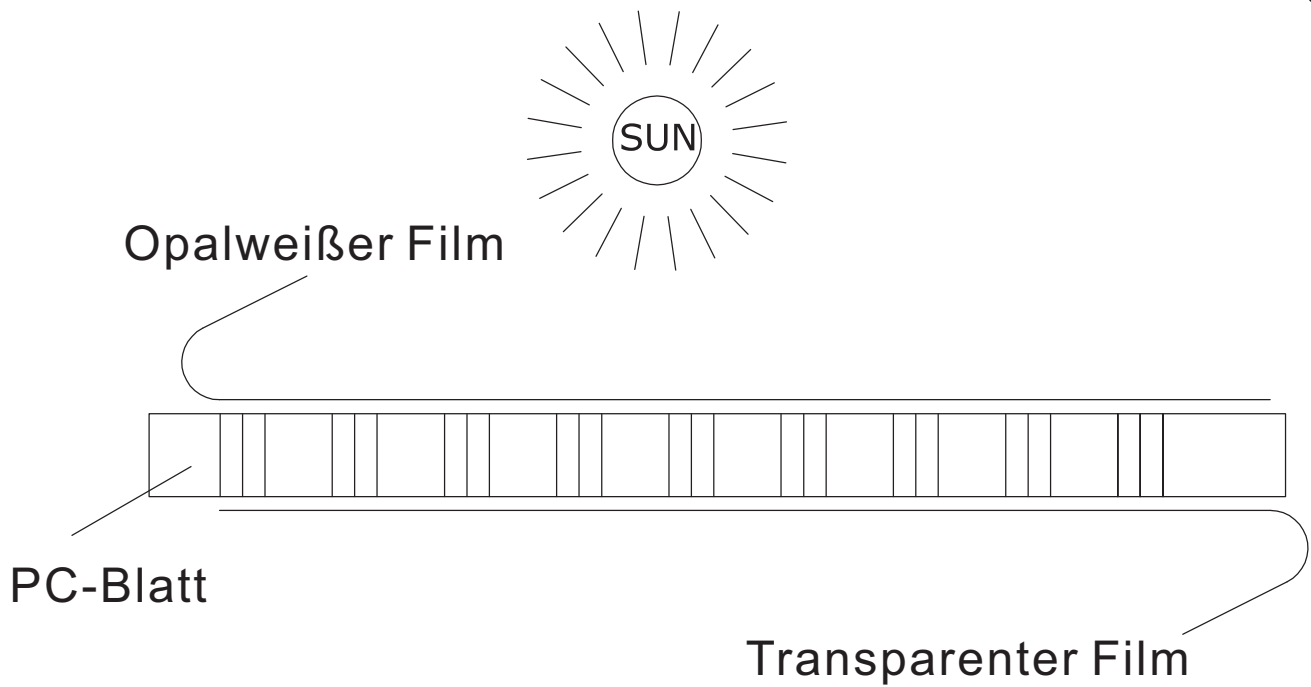



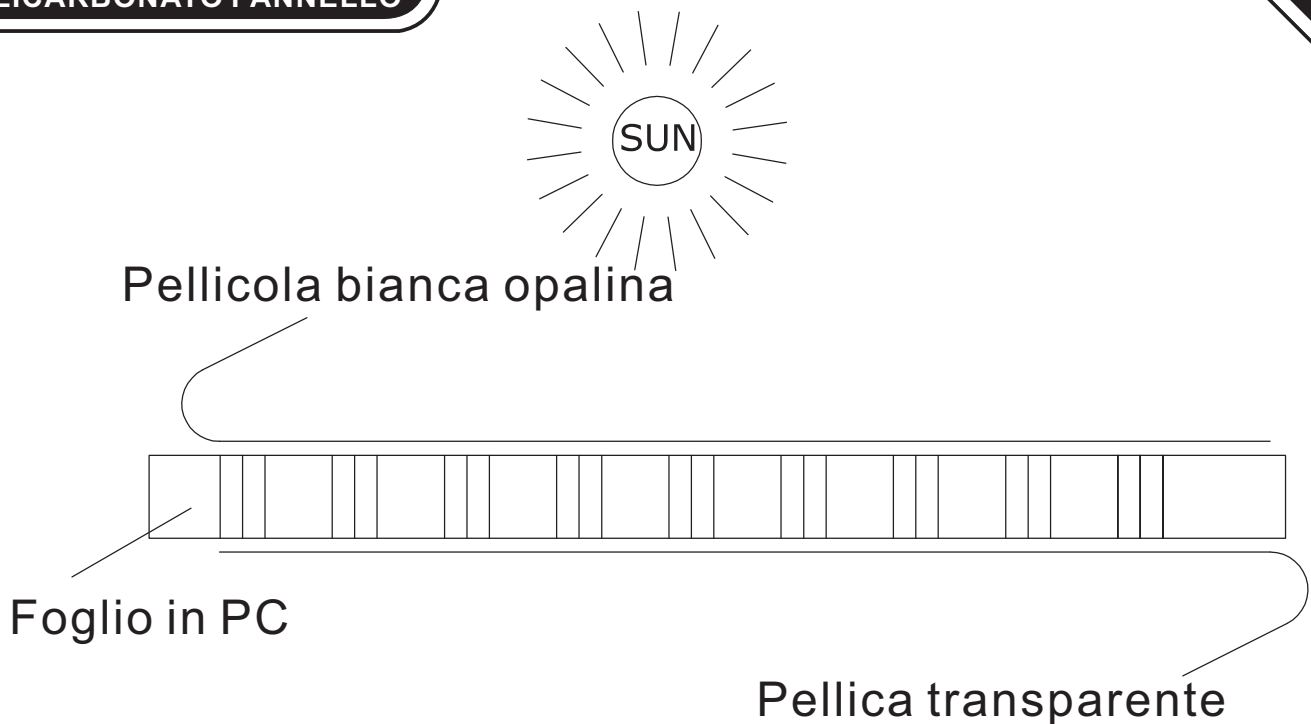





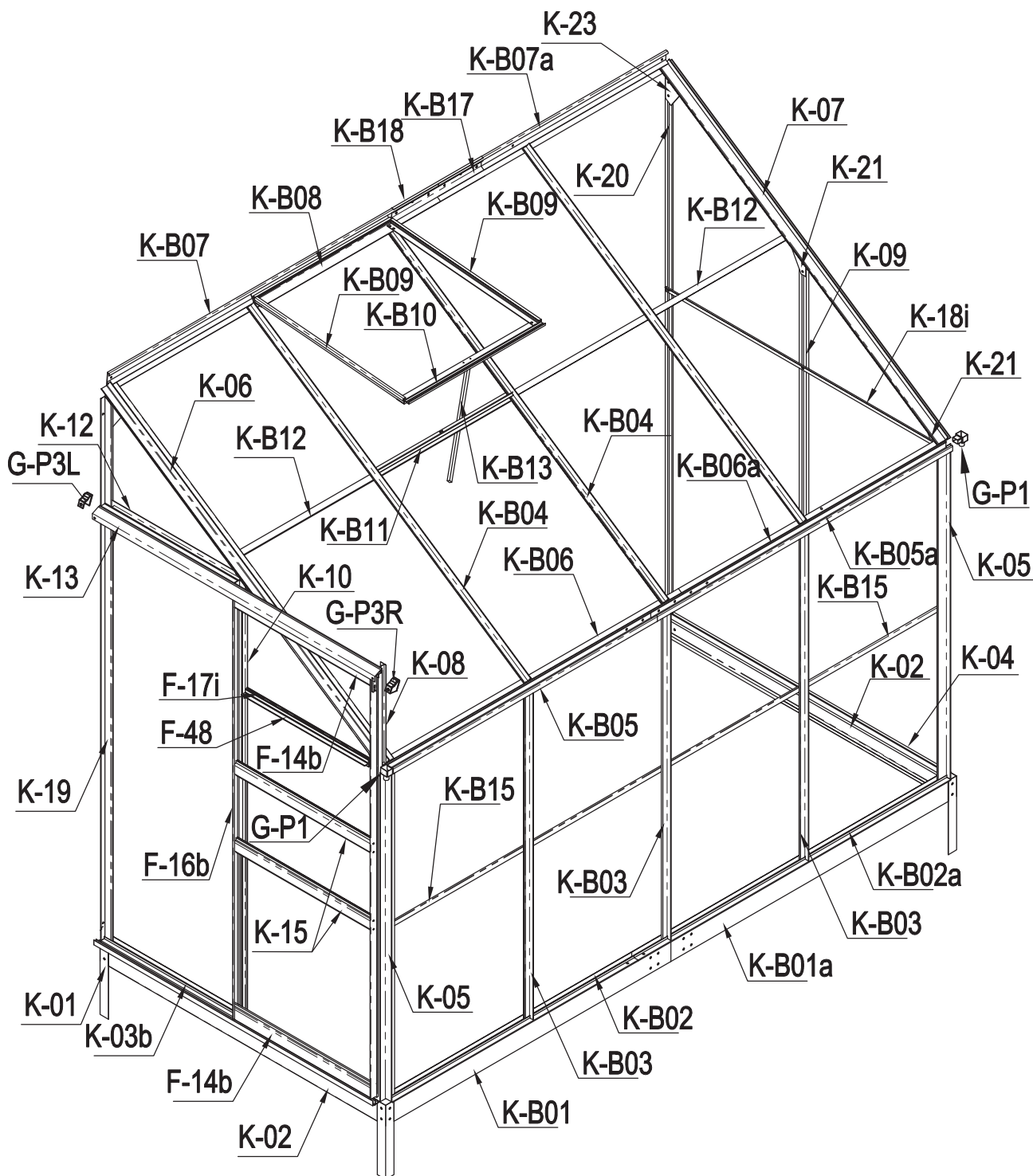







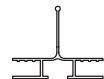













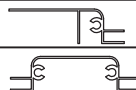

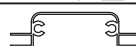











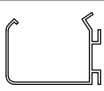







Zwei Seiten des PC-Blatts sind mit einem dünnen Film bedeckt, der Film einer Seite ist transparent, der Film einer anderen ist opalweiß. Die UV-geschützte Seite des Blattes ist mit opalweißem Film bedeckt und muss der Sonne zugewandt sein.







Due lati del foglio in PC sono ricoperti da pellicola sottile. La pellicola di un lato è trasparente, la pellicola di un altro è bianca opaca. Il lato protetto dai raggi UV del foglio ricoperto da una pellicola bianca opalina deve essere rivolto verso il sole.

| Box 1/2       |   |          |               |   |          | Box 2/2            |  |          |
|---------------|---|----------|---------------|---|----------|--------------------|--|----------|
| Name of parts | Section   | QTY(pcs) | Name of parts | Section   | QTY(pcs) | Name of parts      | Section  | QTY(pcs) |
| K-01          |    | 4        | K-B03         |    | 3        | F-31a              |   | 2        |
| K-02          |    | 2        | K-B04         |    | 3        | F-32a              |   | 1        |
| K-03b         |    | 1        | K-B05         |    | 1        | F-33a              |   | 1        |
| K-04          |    | 1        | K-B05a        |   | 1        | K-22               |   | 1        |
| K-05          |    | 2        | K-B06         |    | 1        | K-22a              |   | 1        |
| K-06          |   | 1        | K-B06a        |    | 1        | K-B24              |   | 4        |
| K-07          |   | 1        | K-B07         |    | 1        | K-B25              |   | 3        |
| K-08          |    | 1        | K-B07a        |    | 1        | K-B26              |   | 1        |
| K-09          |    | 1        | K-B08         |    | 1        | K-B27              |   | 1        |
| K-10          |    | 1        | K-B09         |    | 2        | K-B28              |   | 2        |
| K-12          |    | 1        | K-B10         |    | 1        | K-B29              |   | 1        |
| K-13          |   | 1        | K-B11         |   | 1        | K-B23              |  | 1        |
| F-14b         |  | 2        | K-B12         |  | 2        | Instruction manual |  | 1        |
| K-15          |  | 2        | K-B13         |  | 1        |                    |  |          |
| F-16b         |  | 2        | K-B14         |  | 11       |                    |  |          |
| F-17i         |  | 1        | K-B15         |  | 2        |                    |  |          |
| K-18i         |   | 1        | K-B16         |  | 1        |                    |  |          |
| F-48          |  | 2        | K-B17         |  | 1        |                    |  |          |
| K-48          |   | 1        | K-B18         |  | 1        |                    |  |          |
| K-19          |  | 1        | K-B19         |  | 12       |                    |  |          |
| K-20          |   | 1        | K-B30         |  | 128      |                    |  |          |
| K-21          |  | 4        | K-B31a        |  | 12       |                    |  |          |
| K-23          |  | 2        | K-B32         |  | 6        |                    |  |          |
| K-B01         |  | 1        | K-B17g        |  | 34       |                    |  |          |
| K-B01a        |   | 1        | K-B17h        |  | 14       |                    |  |          |
| K-B02         |  | 1        | F-22b         |  | 4        |                    |  |          |
| K-B02a        |   | 1        | G-P1          |  | 2        |                    |  |          |
|               |   |          | G-P3L         |  | 1        |                    |  |          |
|               |   |          | G-P3R         |  | 1        |                    |  |          |
|               |   |          | K-B18g        |  | 48       |                    |  |          |

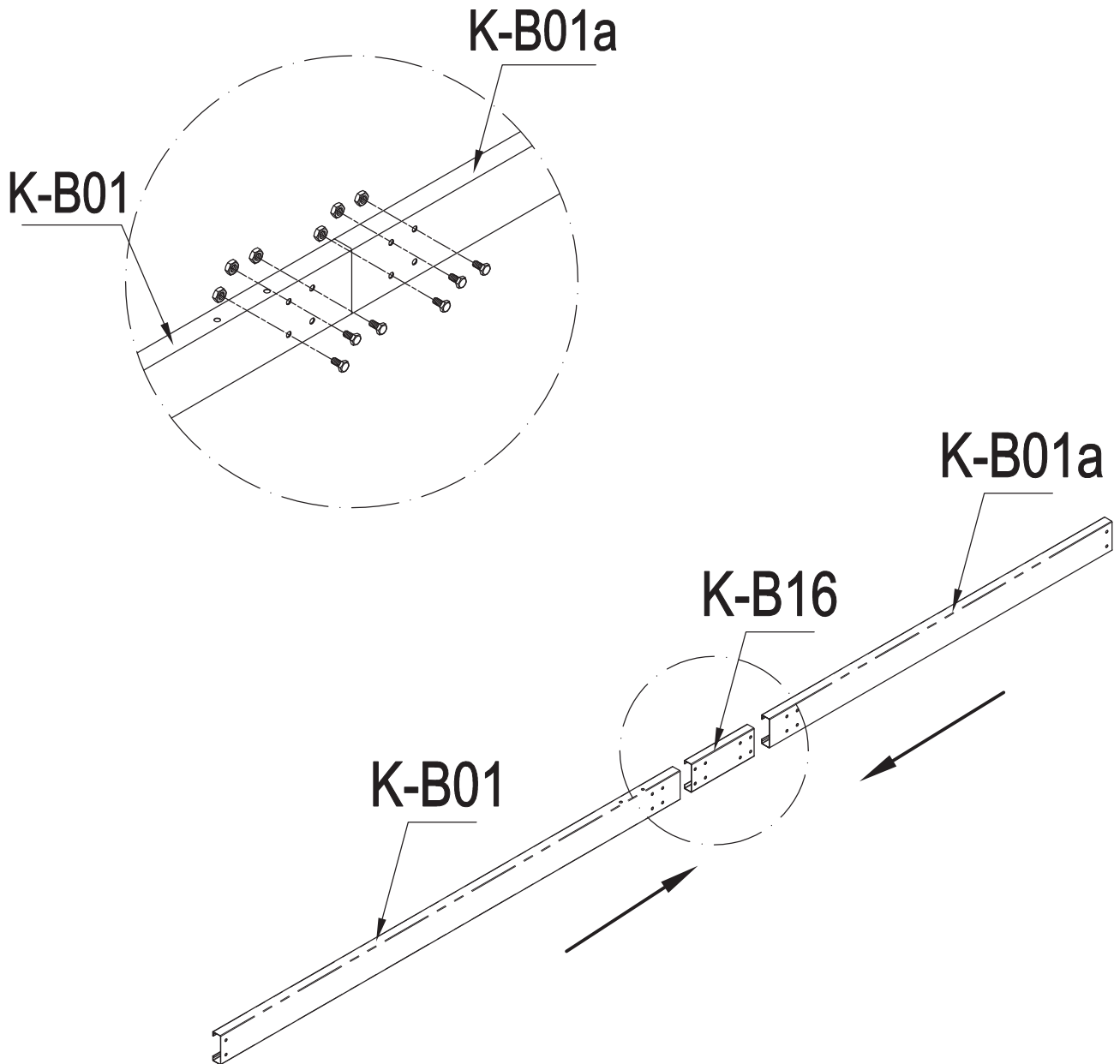



|   |        |        |     |   |        |              |      |
|---|--------|--------|-----|---|--------|--------------|------|
|    | K-03b  | 1215mm | x1  |            | K-B30  |              | x128 |
|    | K-04   | 1215mm | x1  | ST4x10    | K-B31a |              | x12  |
|   | K-B02  | 1070mm | x1  | ST4x8     | K-B32  |              | x6   |
|   | K-B02a | 1362mm | x1  |            | K-B14  |              | x11  |
|    | K-B03  | 1240mm | x3  |            | G-P1   |              | x2   |
|   | K-B04  | 1456mm | x3  |            | G-P3L  |              | x1   |
|   | K-09   | 1651mm | x1  |            | G-P3R  |              | x1   |
|    | K-05   | 1240mm | x2  |            | K-02   | 1240mm       | x2   |
|   | K-06   | 1465mm | x1  |   | K-B01  | 1241mm       | x1   |
|   | K-07   | 1465mm | x1  |   | K-B01a | 1241mm       | x1   |
|    | K-08   | 376mm  | x1  |            | K-B16  | 200mm        | x1   |
|    | K-10   | 1644mm | x1  |            | K-01   | 280mm        | x4   |
|   | K-19   | 2044mm | x1  |            | F-48   | 568mm        | x2   |
|   | K-20   | 2044mm | x1  |   | K-48   | 553mm        | x1   |
|    | K-12   | 580mm  | x1  |            | F-31a  | 1217mmx585mm | x2   |
|    | K-13   | 1230mm | x1  |            | K-22   | 1217mmx570mm | x1   |
|   | F-14b  | 600mm  | x2  |            | F-32a  |              | x1   |
|   | K-15   | 600mm  | x2  |           | F-33a  |              | x1   |
|  | F-16b  | 1615mm | x2  |          | K-22a  |              | x1   |
|  | F-17i  | 618mm  | x1  |          | K-B23  |              | x1   |
|   | K-18i  | 1203mm | x1  |          | K-B24  | 1238mmx585mm | x4   |
|  | K-21   |        | x4  |          | K-B25  | 1473mmx585mm | x3   |
|  | F-22b  |        | x4  |          | K-B26  | 677mmx597mm  | x1   |
|  | K-23   |        | x2  |          | K-B27  | 812mmx585mm  | x1   |
|  | K-B05  | 1150mm | x1  |          | K-B28  | 590mmx598mm  | x2   |
|   | K-B05a | 1286mm | x1  |          | K-B29  | 251mmx598mm  | x1   |
|  | K-B06  | 1288mm | x1  | ST4x13  | K-B17g |              | x34  |
|   | K-B06a | 1144mm | x1  | ST4x16  | K-B17h |              | x14  |
|  | K-B07  | 1432mm | x1  |          | K-B18g |              | x48  |
|   | K-B07a | 1000mm | x1  |   |        |              |      |
|  | K-B08  | 595mm  | x1  |   |        |              |      |
|  | K-B09  | 650mm  | x2  |   |        |              |      |
|  | K-B10  | 595mm  | x1  |   |        |              |      |
|  | K-B11  | 620mm  | x1  |   |        |              |      |
|  | K-B12  | 1216mm | x2  |   |        |              |      |
|  | K-B13  | 360mm  | x1  |   |        |              |      |
|  | K-B15  | 1216mm | x2  |   |        |              |      |
|  | K-B17  | 390mm  | x1  |   |        |              |      |
|  | K-B18  | 390mm  | x1  |   |        |              |      |
|  | K-B19  |        | x12 |   |        |              |      |



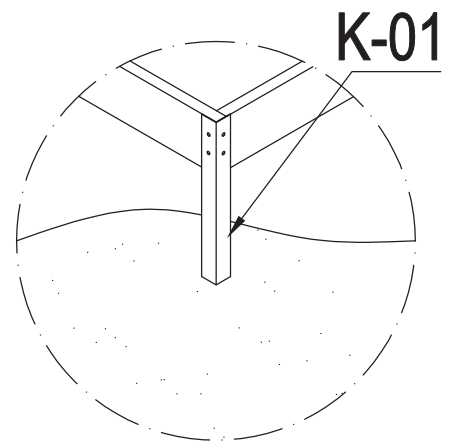
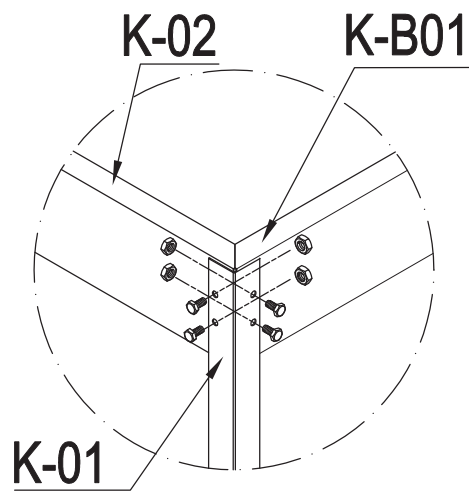
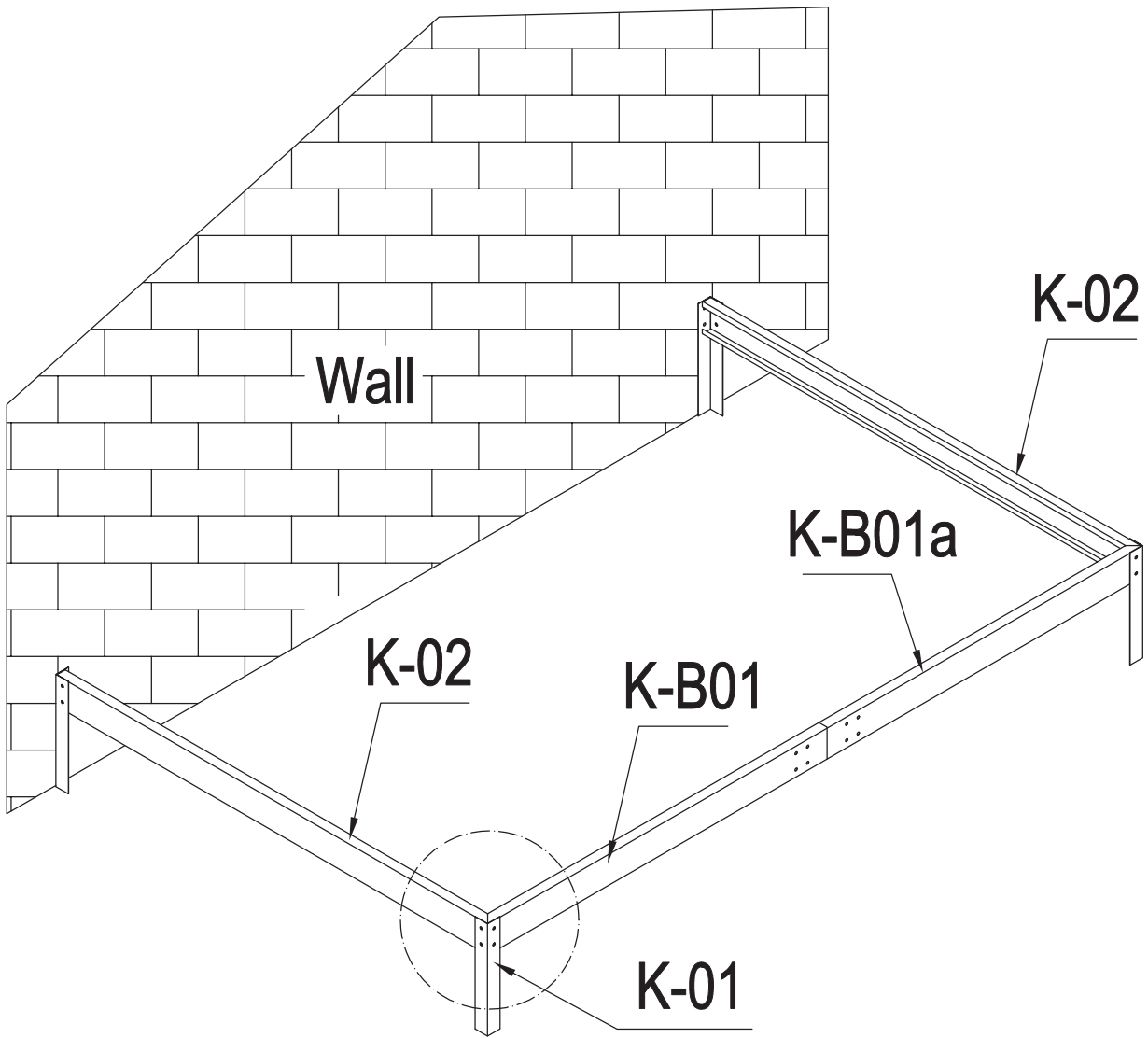





|   |        |   |
|---|--------|---|
|  | K-B01  | 1 |
|  | K-B01a | 1 |
|  | K-B16  | 1 |
|  | K-B31  | 8 |

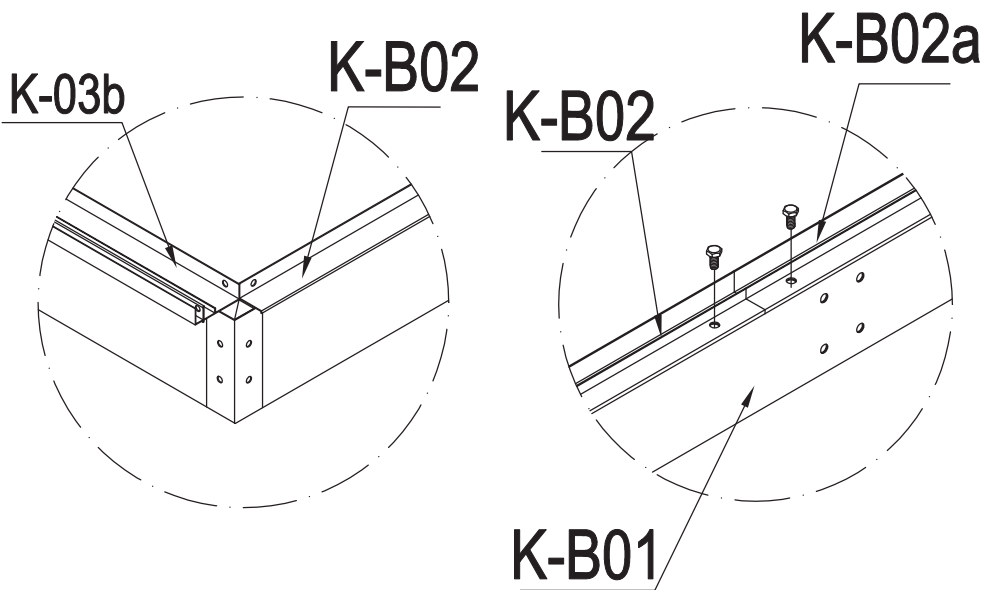
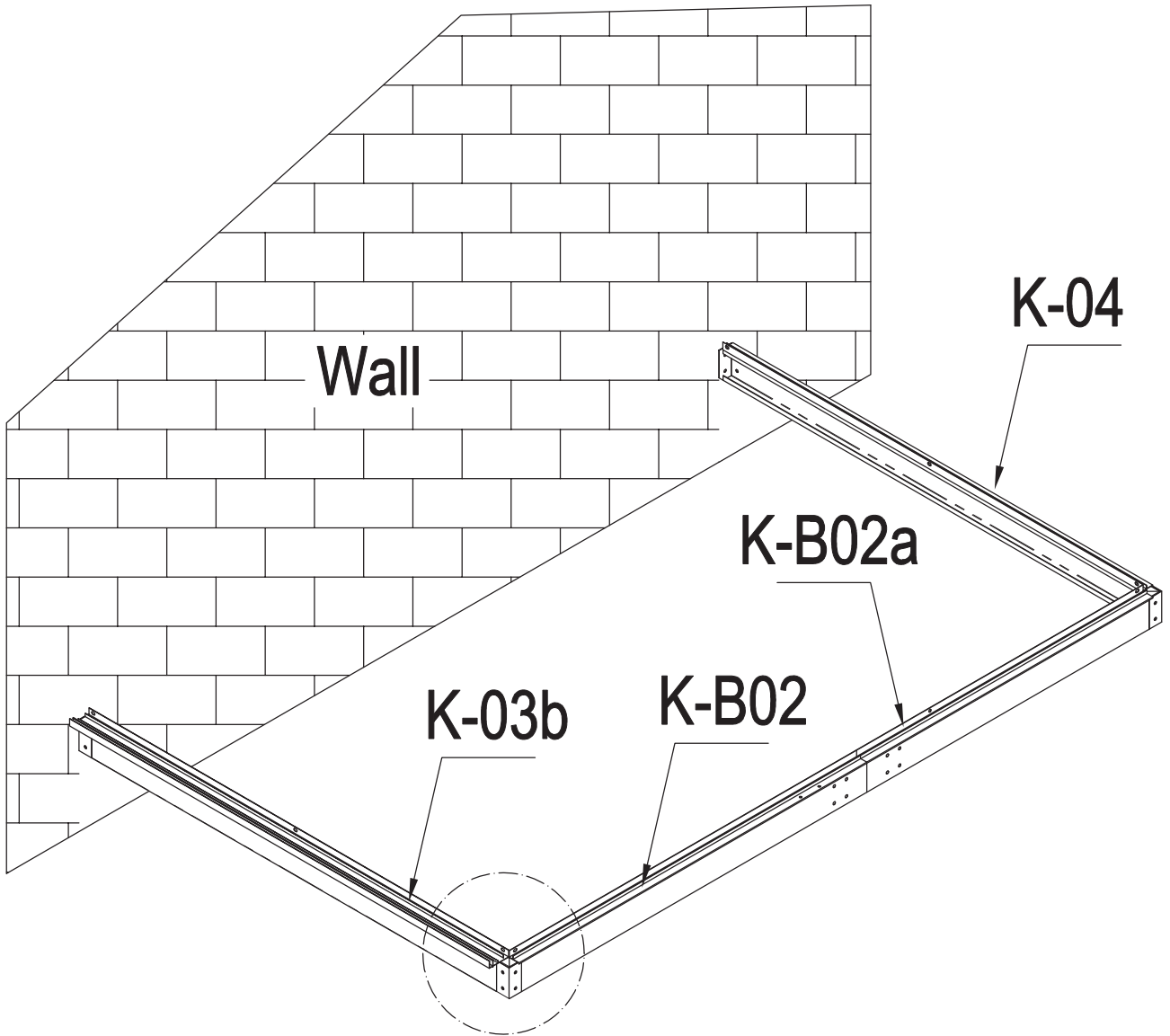





|   |       |    |
|---|-------|----|
|  | K-01  | 4  |
|  | K-B31 | 12 |



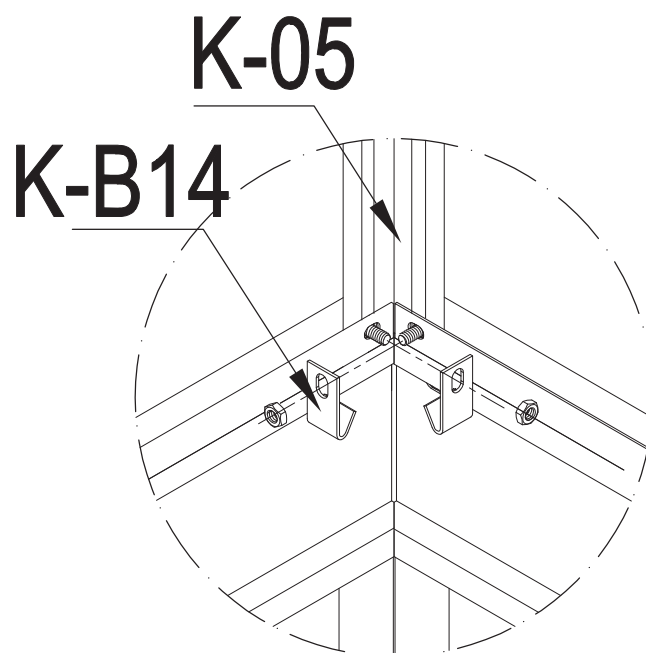
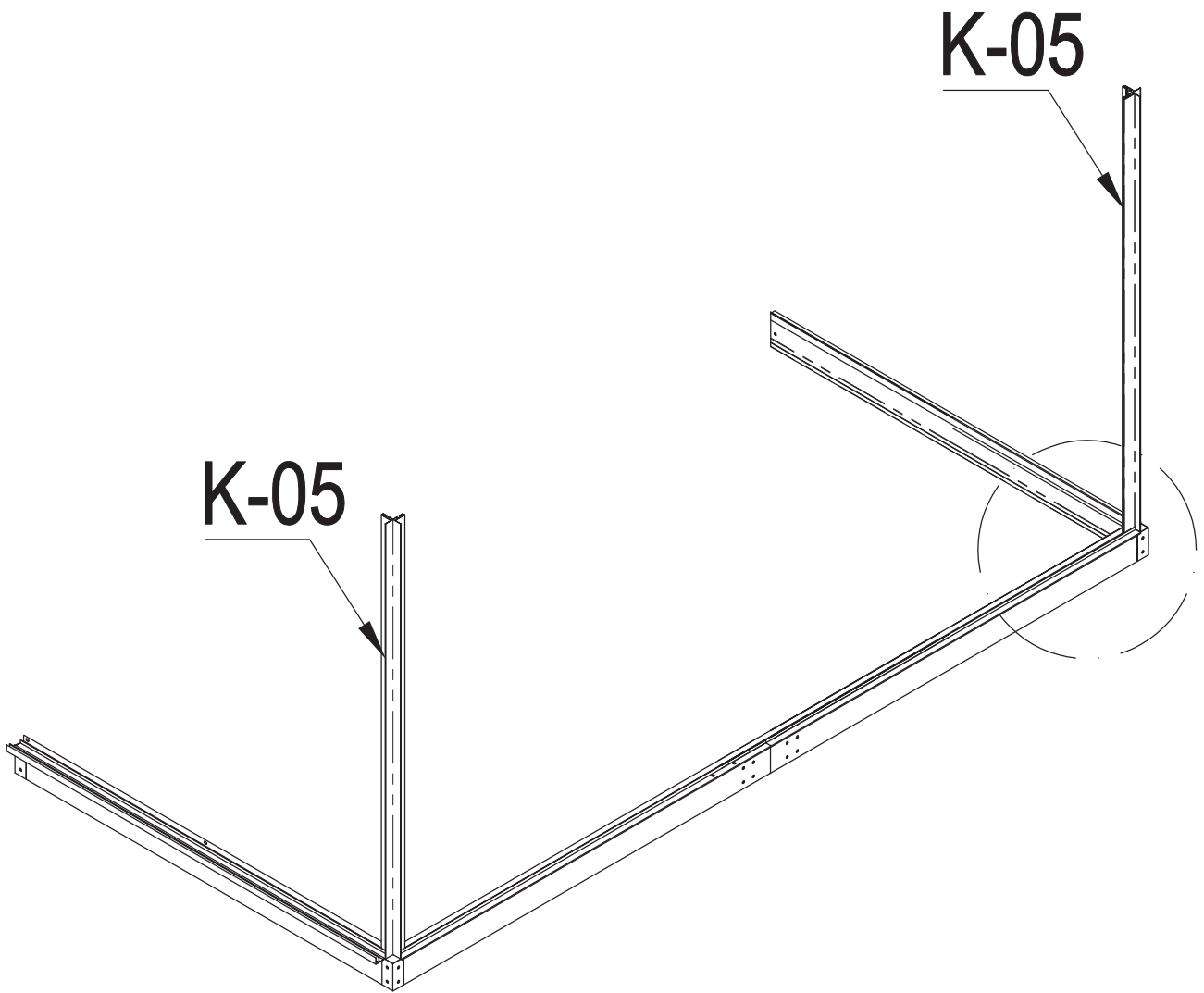





|   |        |   |
|---|--------|---|
|  | K-B02  | 1 |
|  | K-B02a | 1 |
|  | K-03b  | 1 |
|  | K-04   | 1 |
|  | K-B31  | 2 |

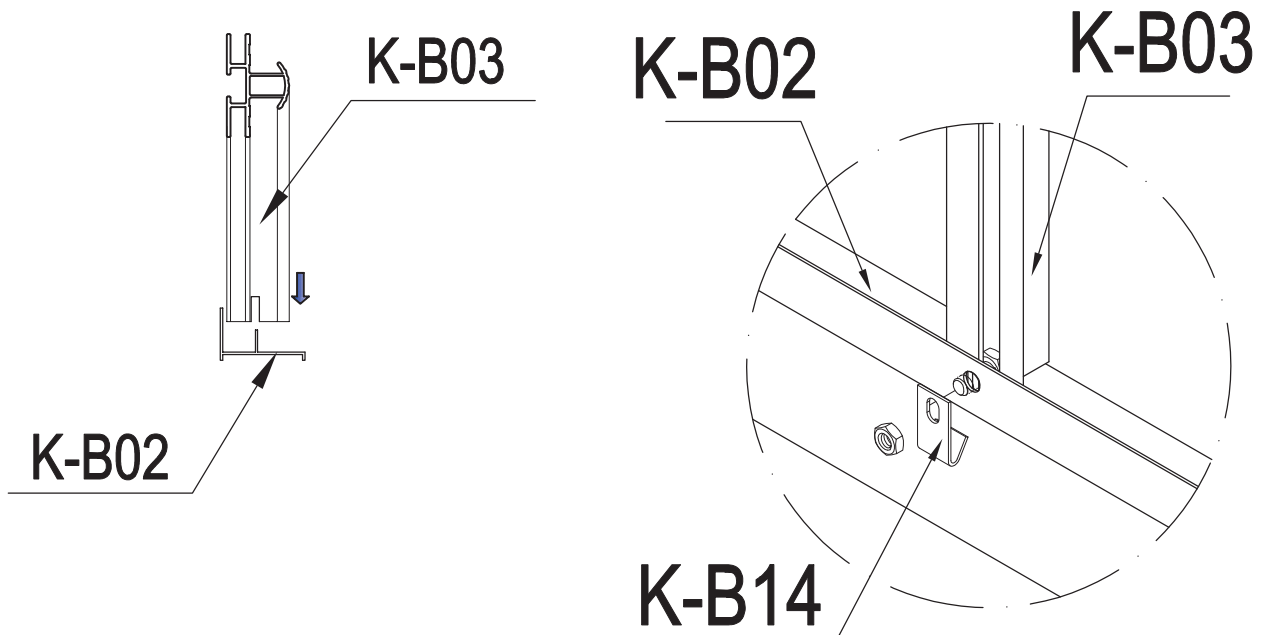
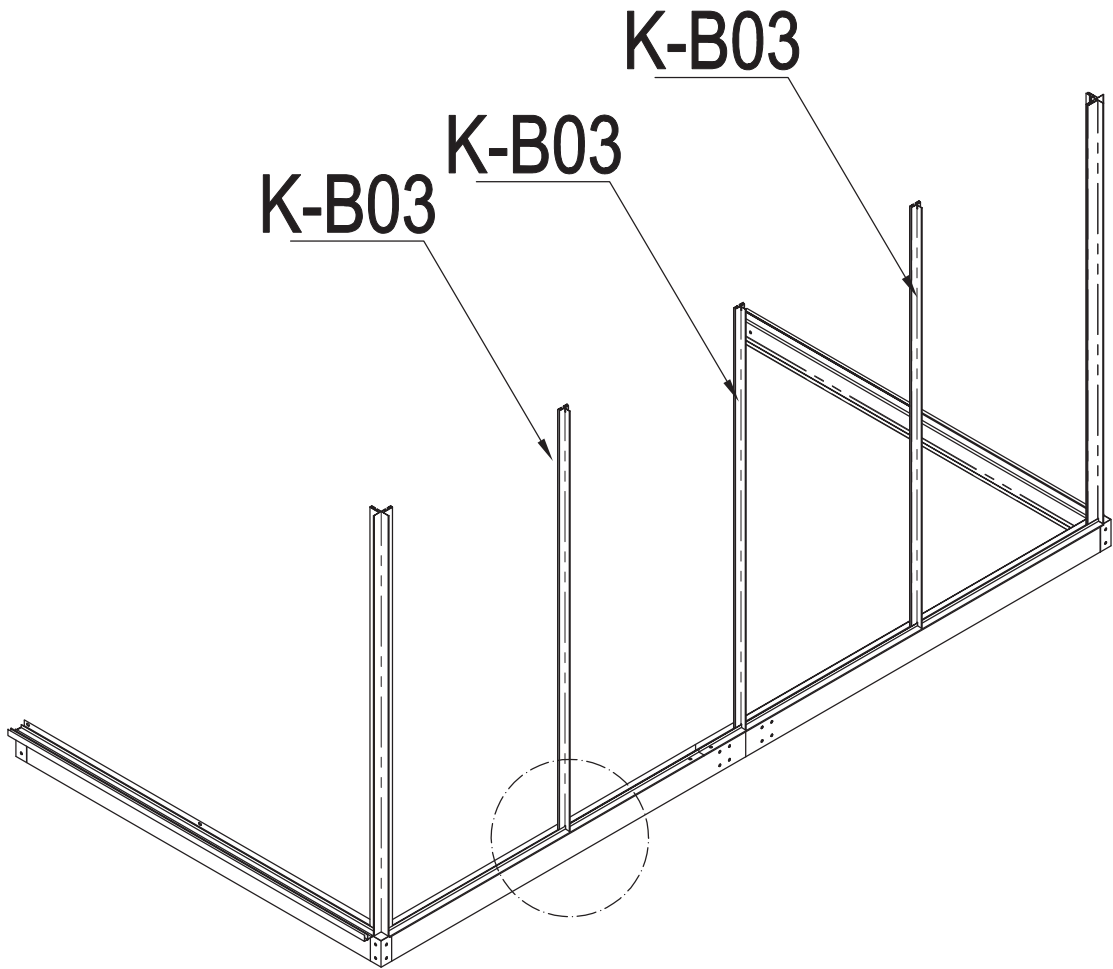



|   |       |   |
|---|-------|---|
|  | K-05  | 2 |
|  | K-B14 | 4 |
|  | K-B31 | 4 |

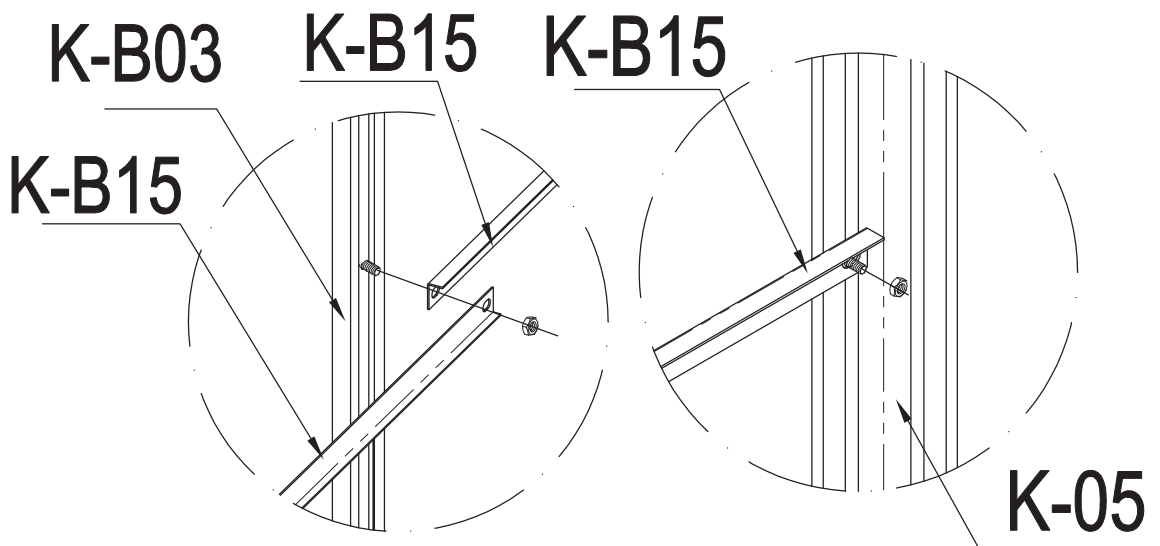
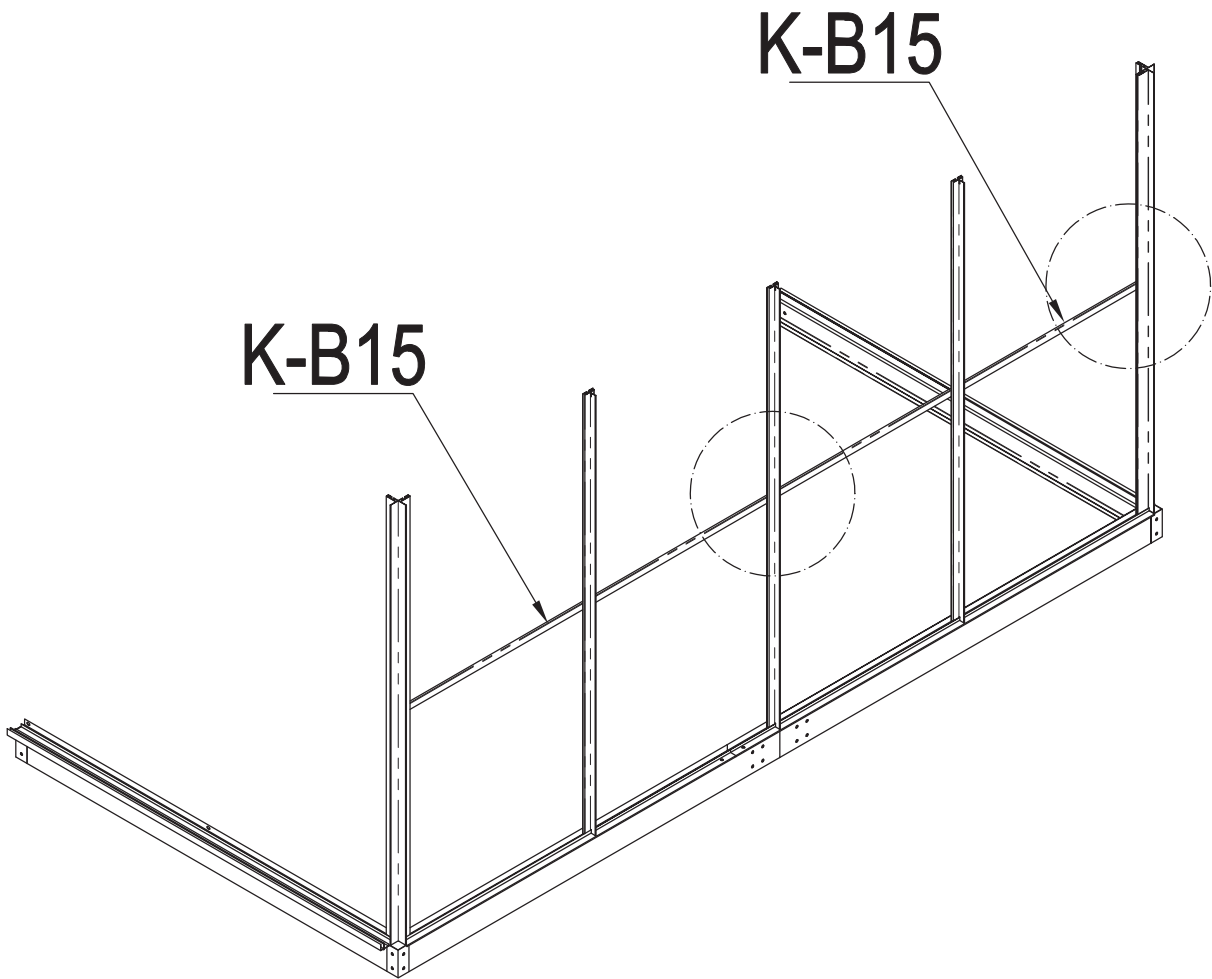

|   |       |   |
|---|-------|---|
|  | K-B03 | 3 |
|  | K-B14 | 3 |
|  | K-B31 | 3 |



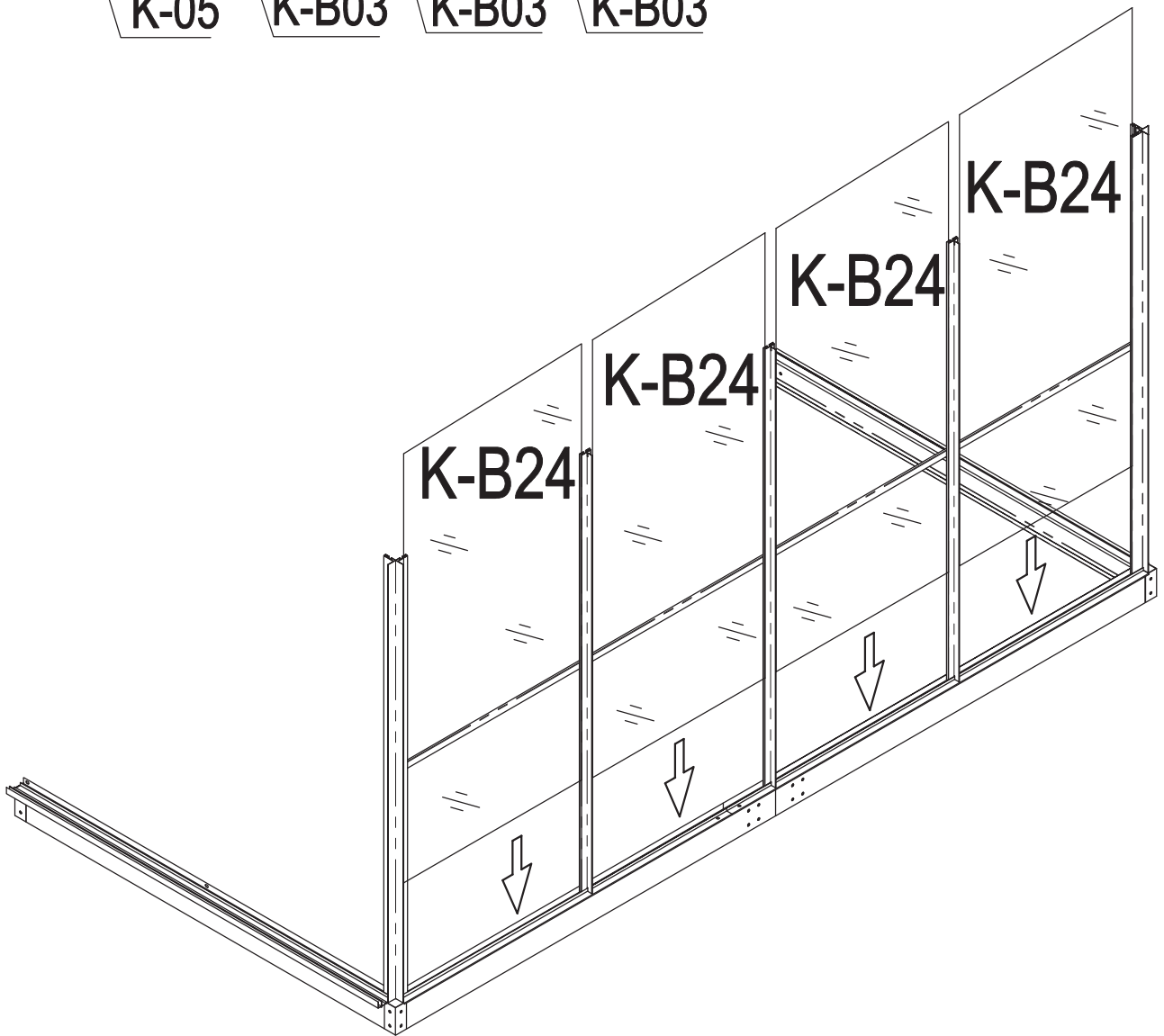
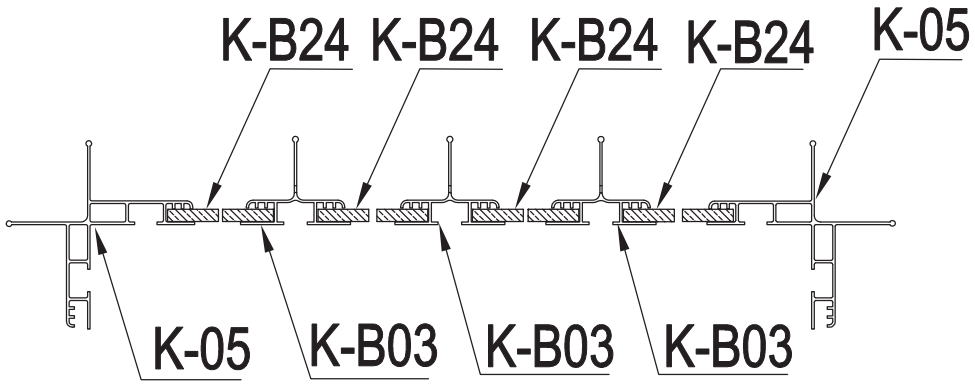

|   |       |   |
|---|-------|---|
|  | K-B15 | 2 |
|  | K-B31 | 5 |



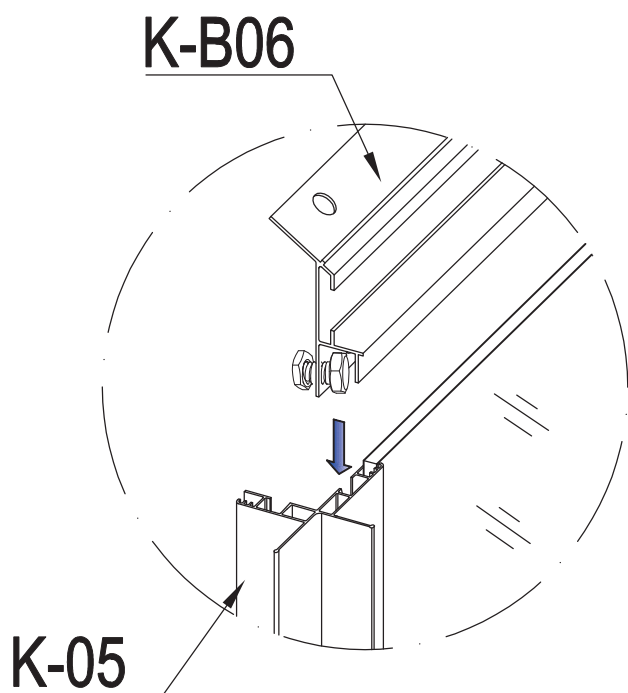
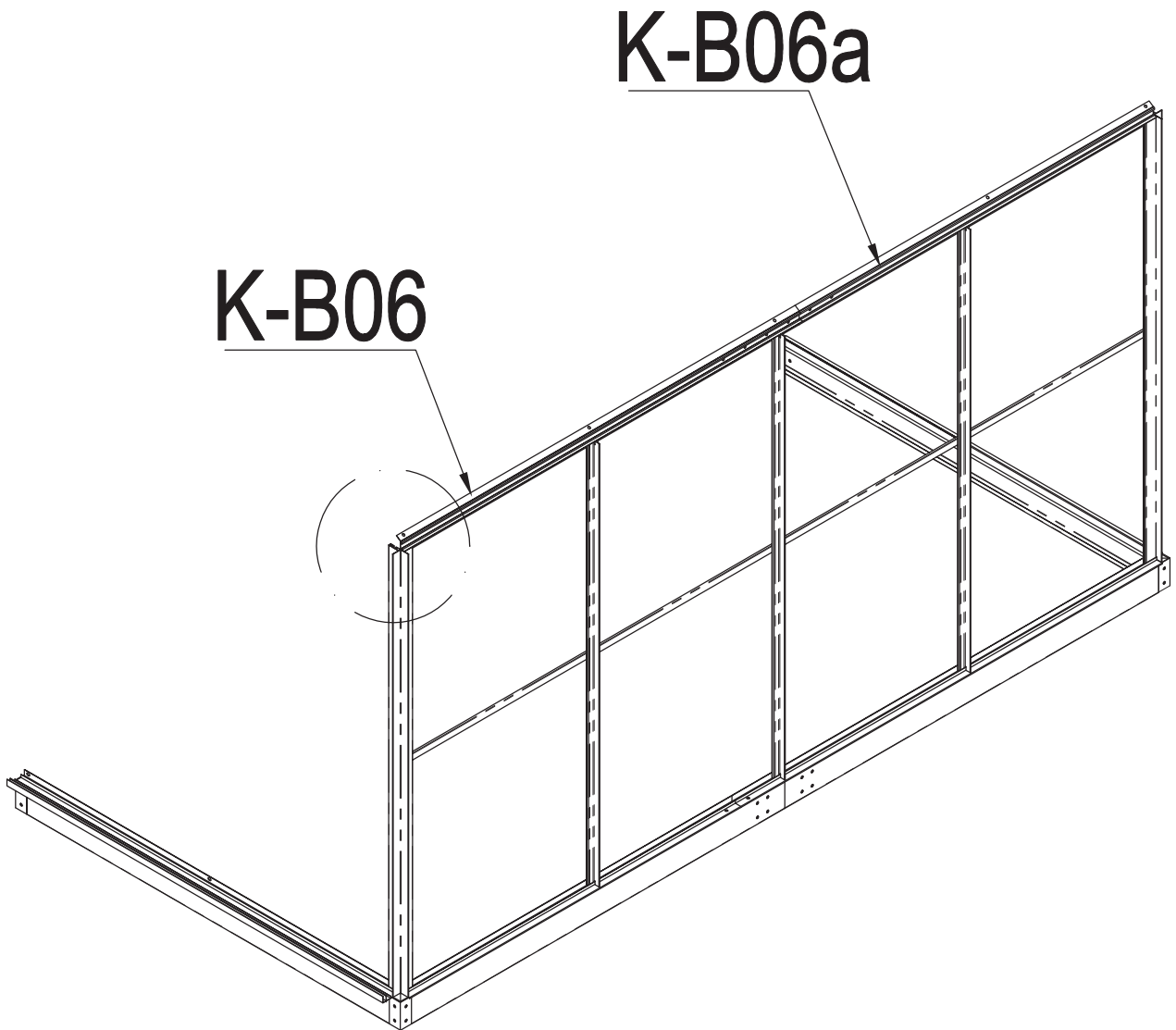

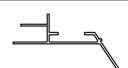
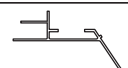

|  |       |   |
|--|-------|---|
|  | K-B24 | 4 |
|--|-------|---|

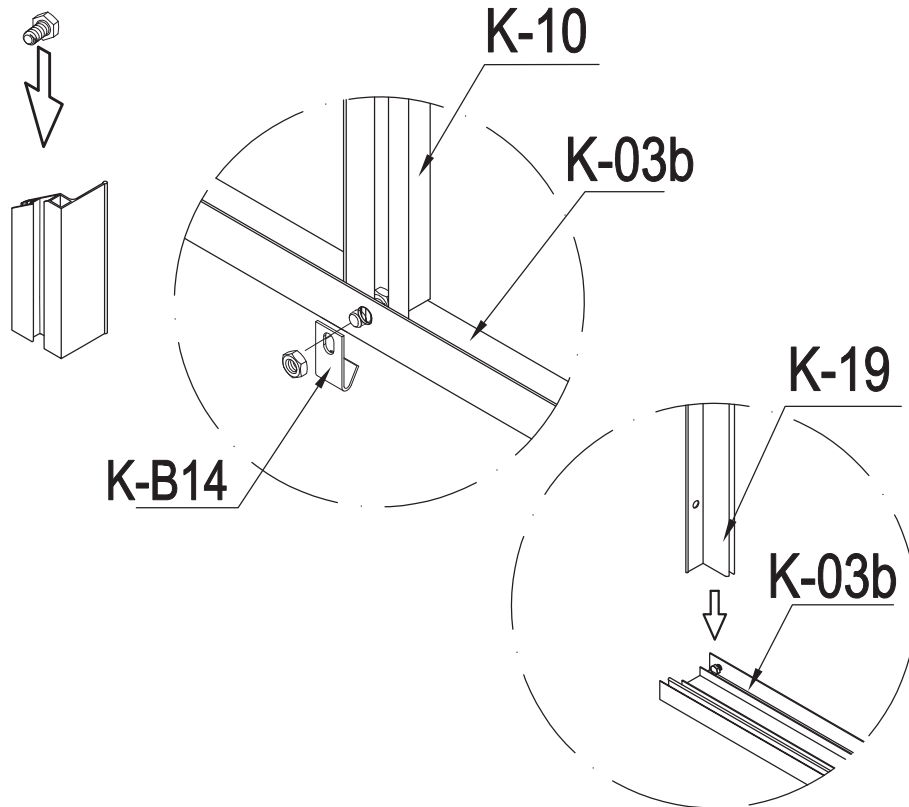
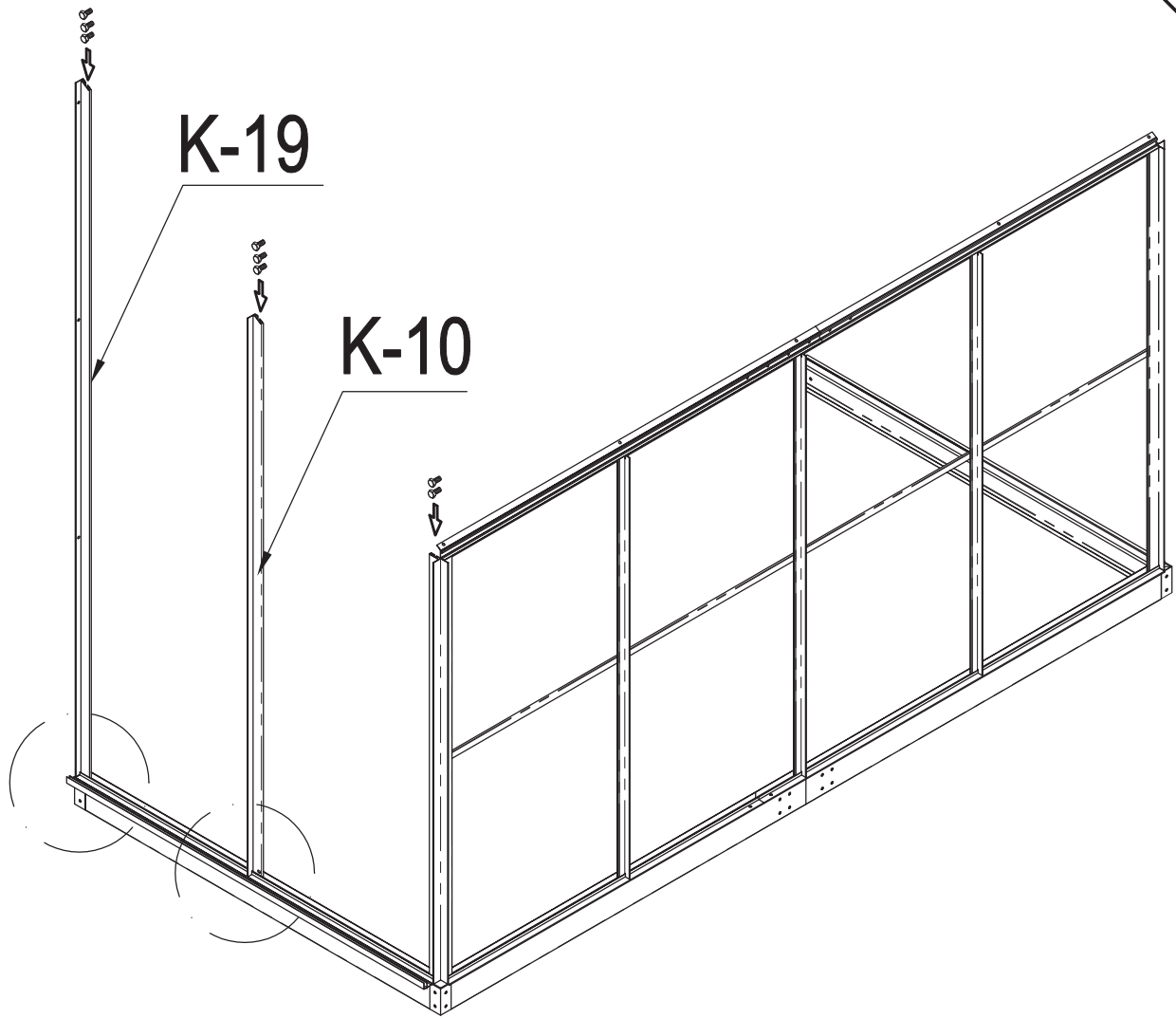



|   |        |   |
|---|--------|---|
|  | K-B06  | 1 |
|  | K-B06a | 1 |
|  | K-B31  | 5 |



|   |       |    |
|---|-------|----|
|  | K-10  | 1  |
|  | K-19  | 1  |
|  | K-B14 | 2  |
|  | K-B31 | 10 |
|  | K-B31 | 2  |

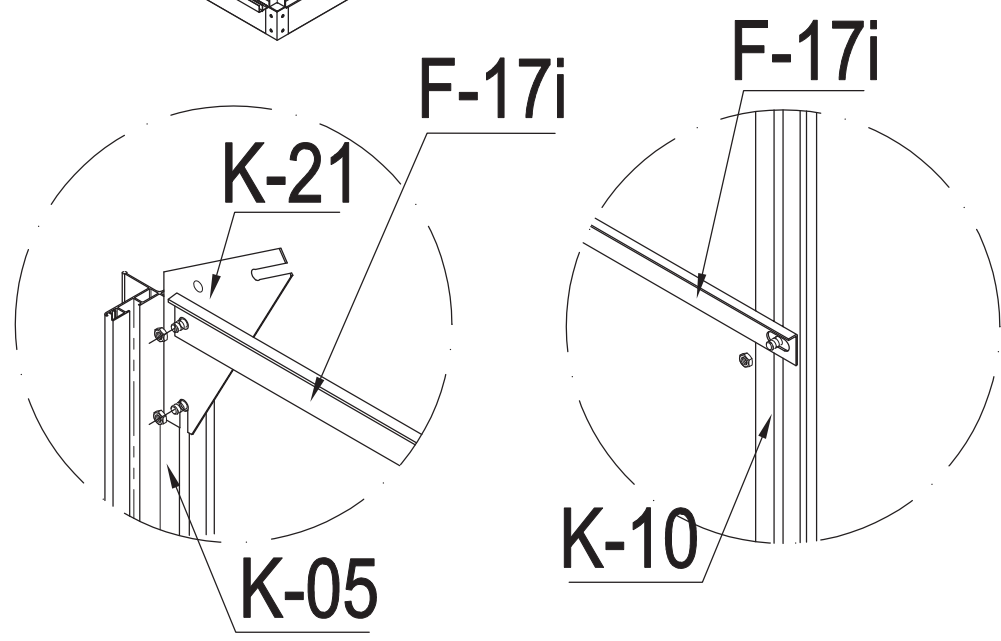
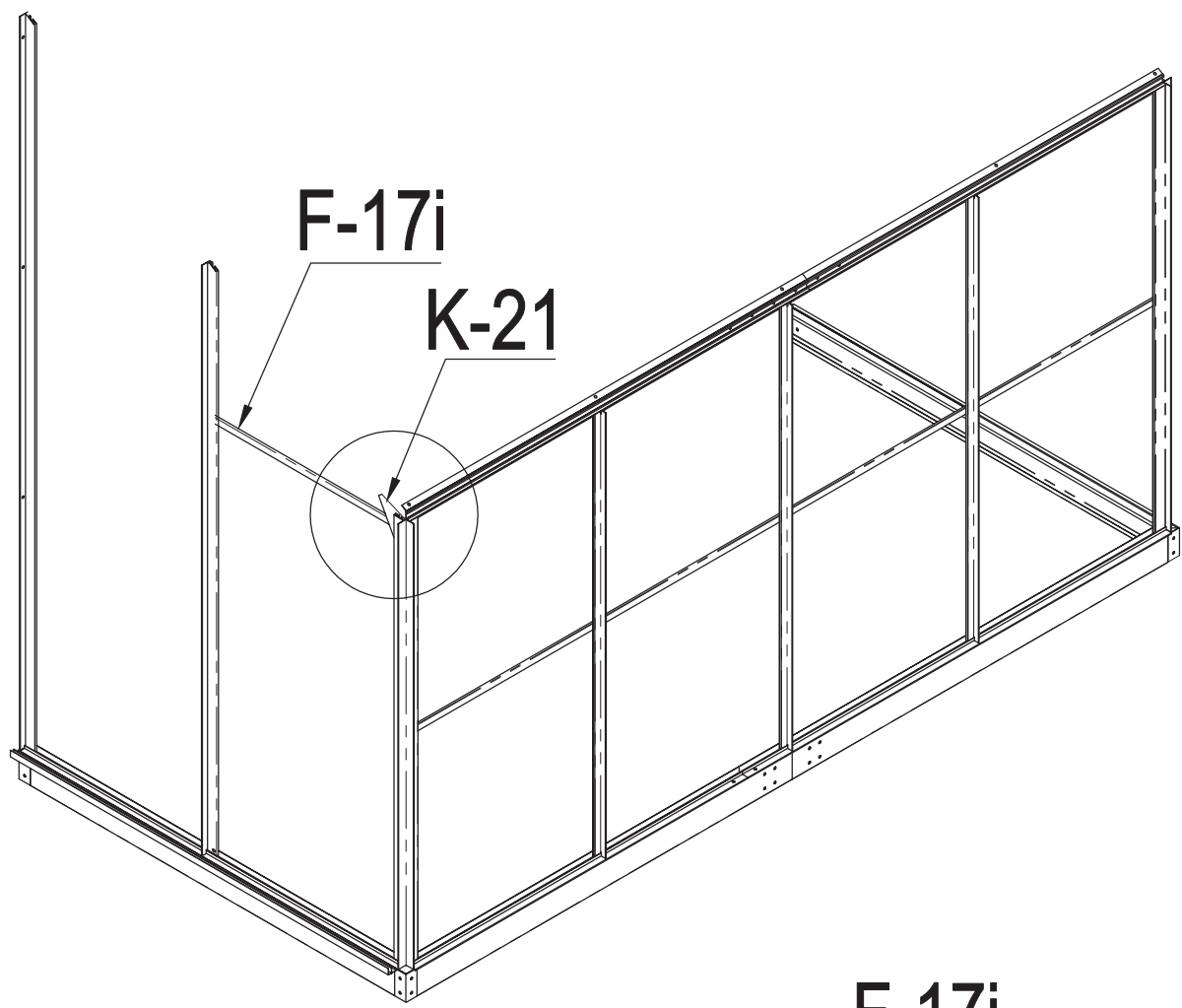

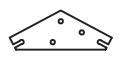



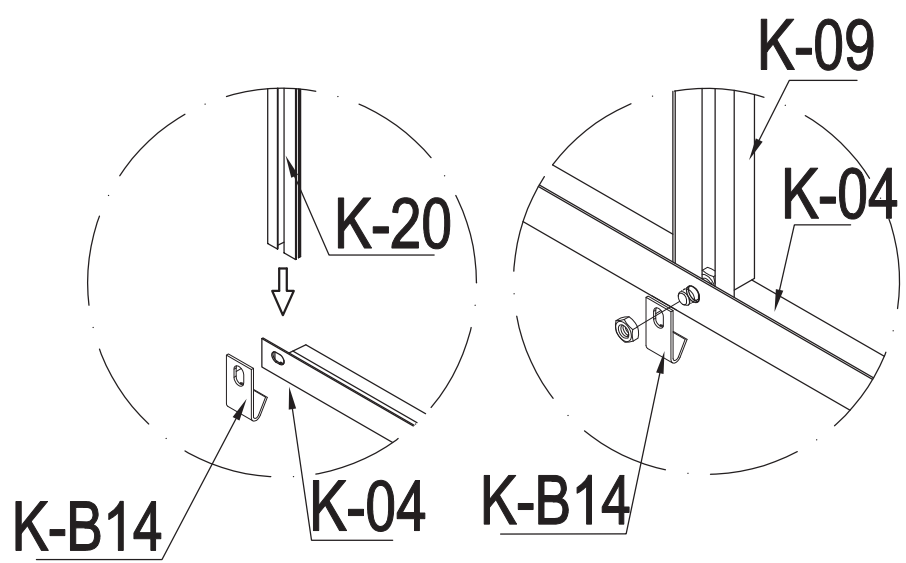
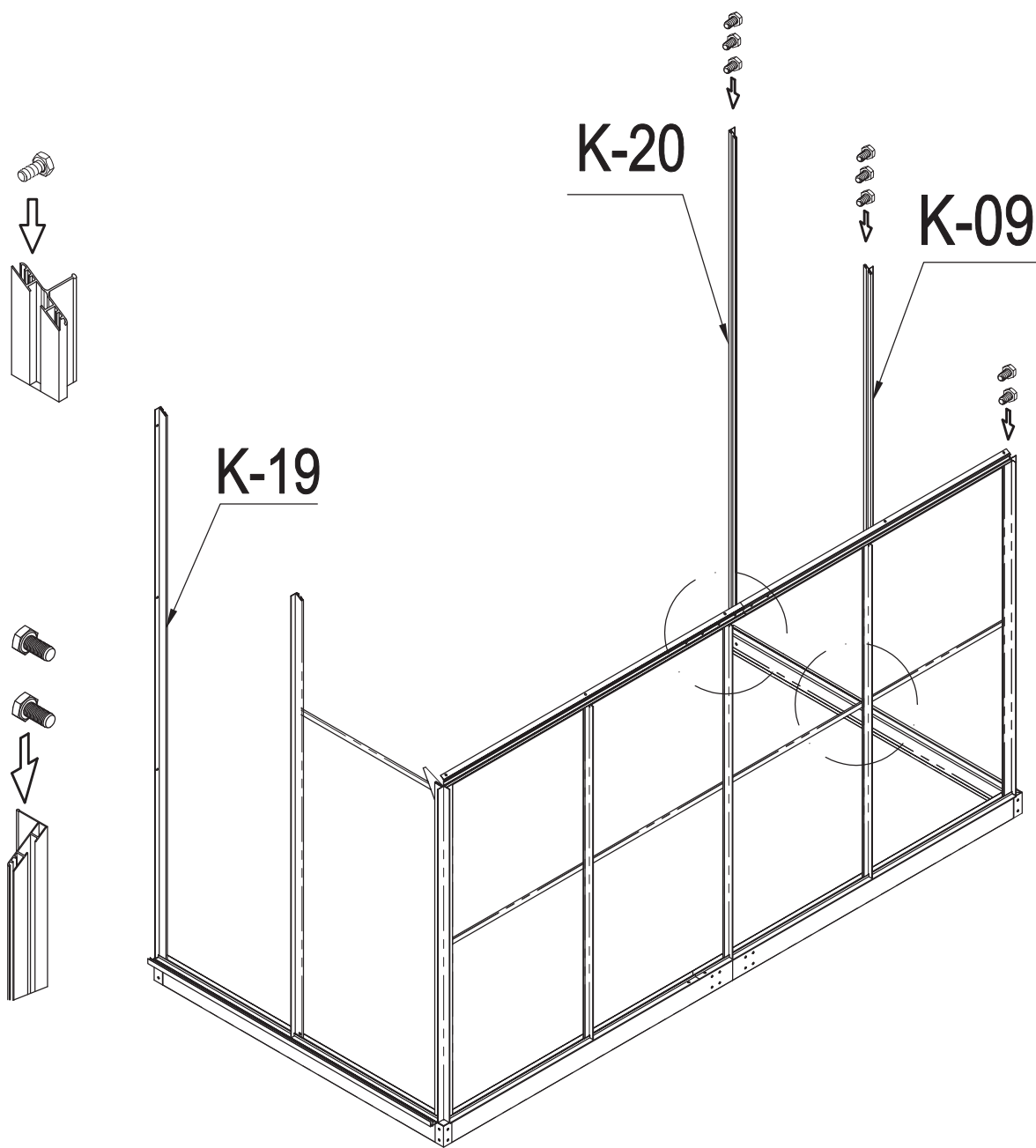

|   |       |   |
|---|-------|---|
|  | K-21  | 1 |
|  | F-17i | 1 |
|  | K-B31 | 3 |



11

|   |       |    |
|---|-------|----|
|  | K-09  | 1  |
|  | K-B14 | 2  |
|  | K-20  | 1  |
|  | K-B31 | 10 |
|  | K-B31 | 2  |

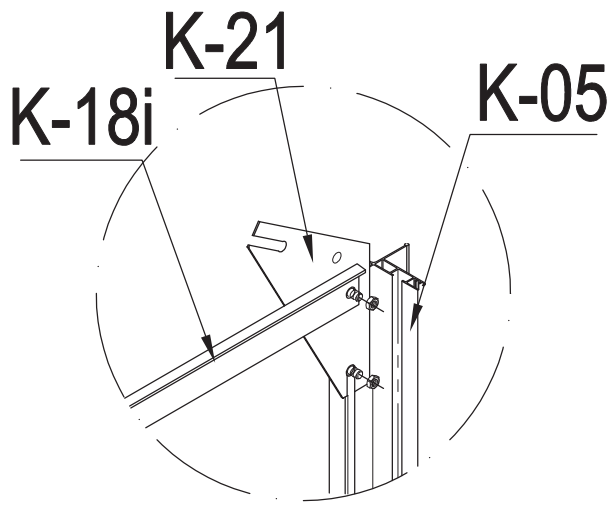
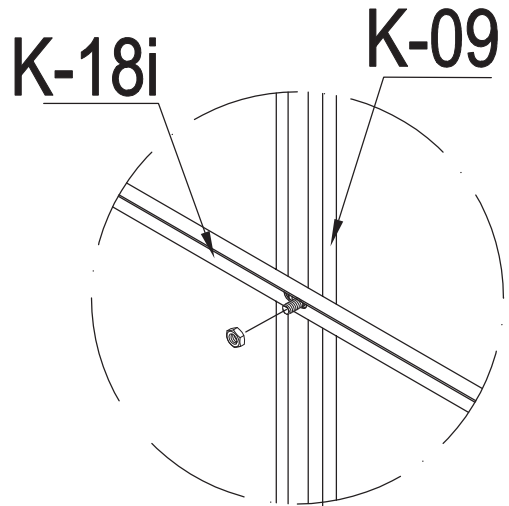
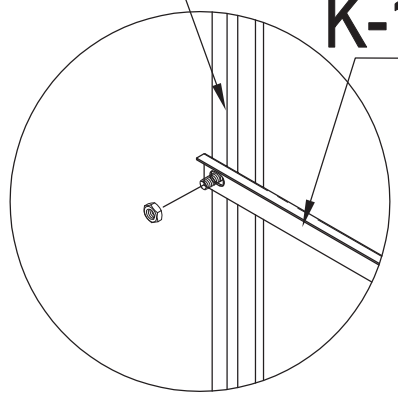
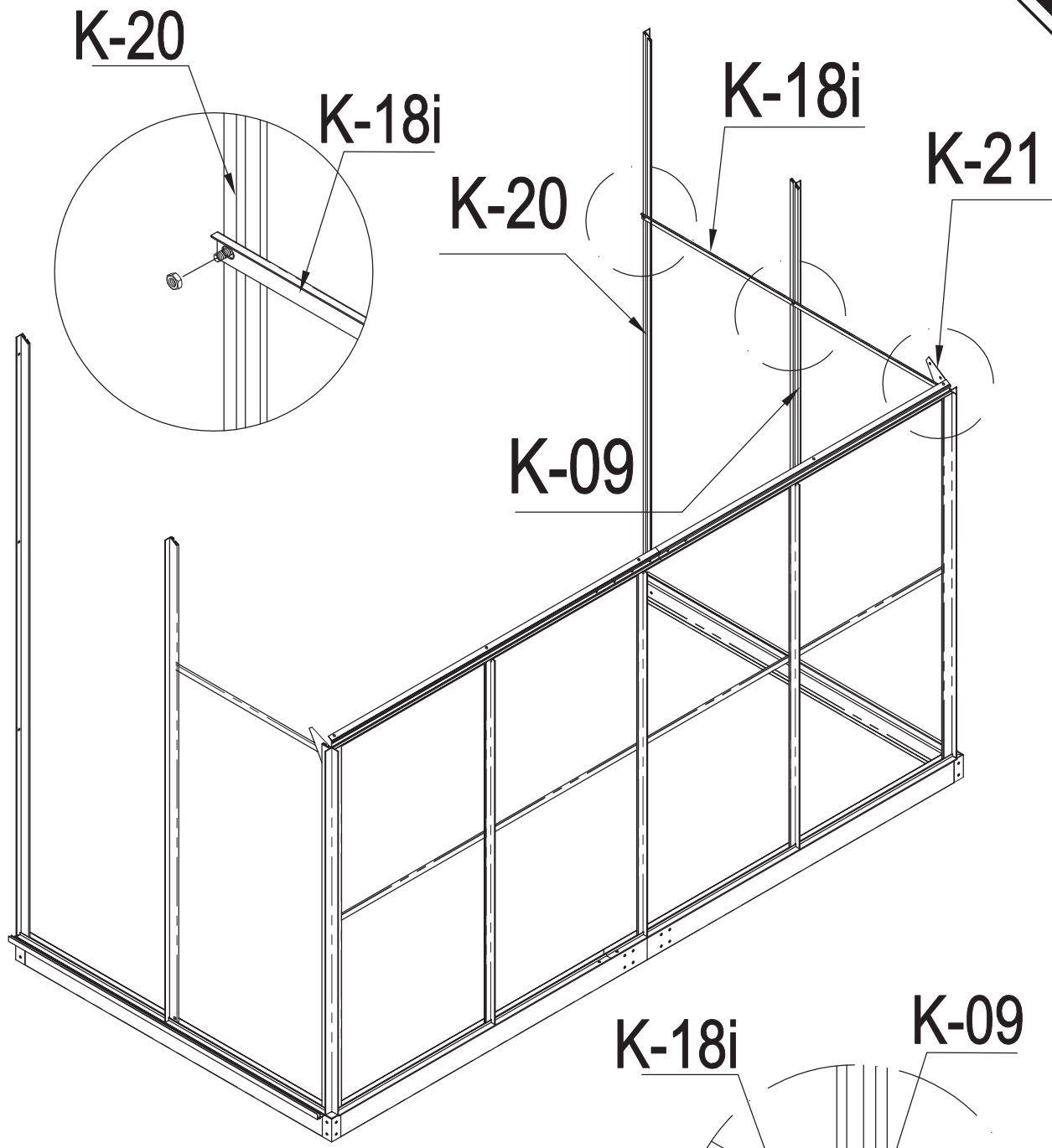

|  |       |   |
|--|-------|---|
|  | K-21  | 1 |
|  | F-18i | 1 |
|  | K-B31 | 4 |

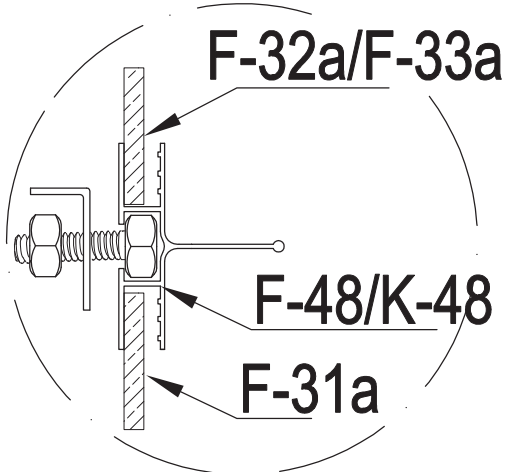
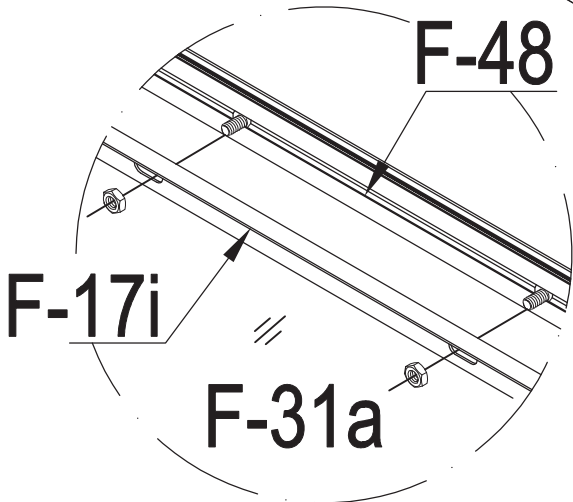
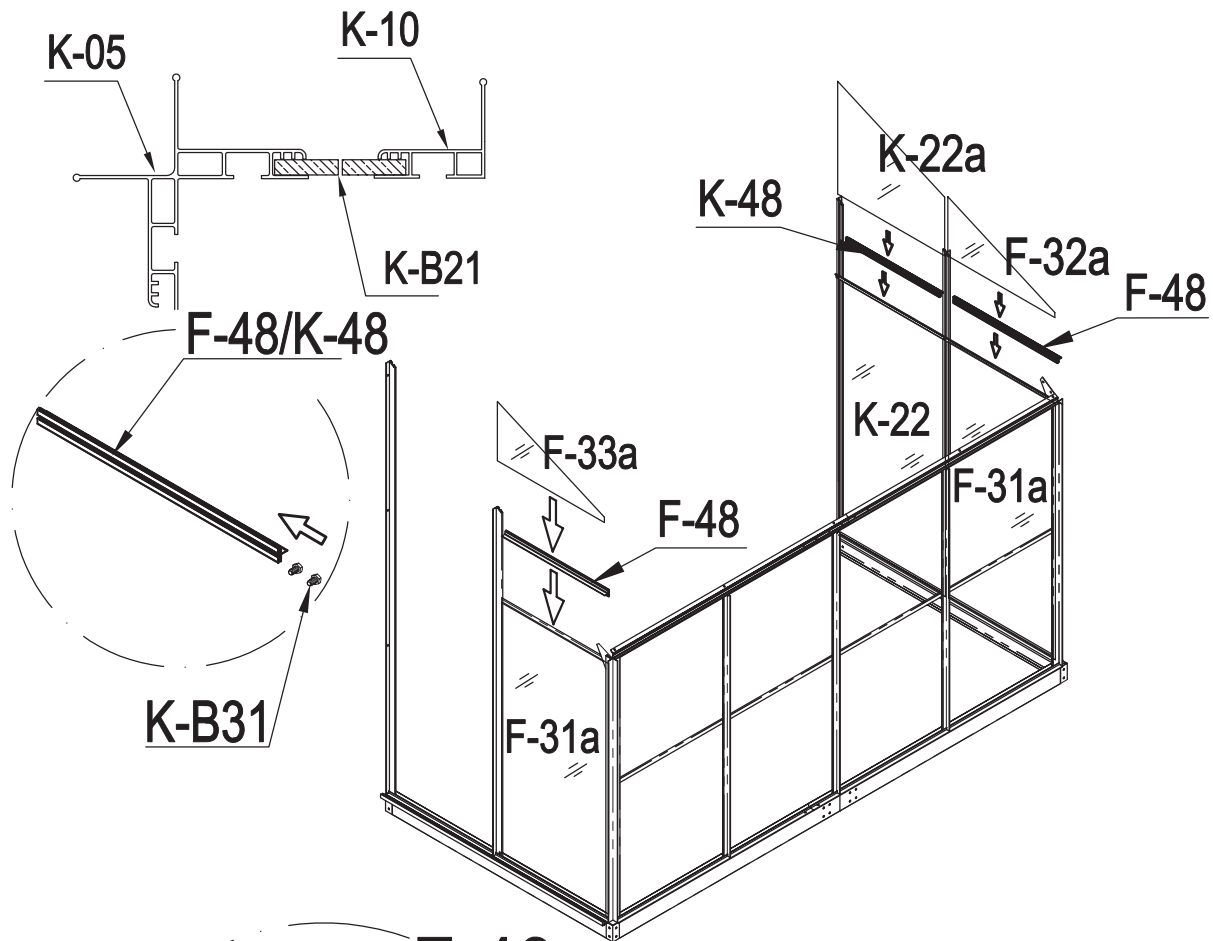

|  |       |   |
|--|-------|---|
|  | F-31a | 2 |
|  | K-22  | 1 |
|  | F-32a | 1 |
|  | F-33a | 4 |
|  | K-22a | 1 |
|  | F-48  | 2 |
|  | K-48  | 1 |
|  | K-B31 | 6 |
|  | K-B31 | 6 |

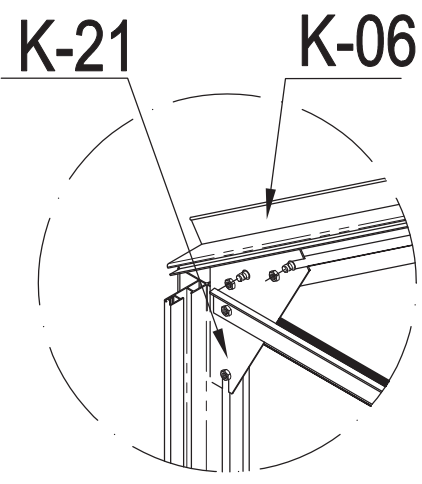

K-21

K-06

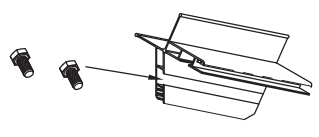

K-06

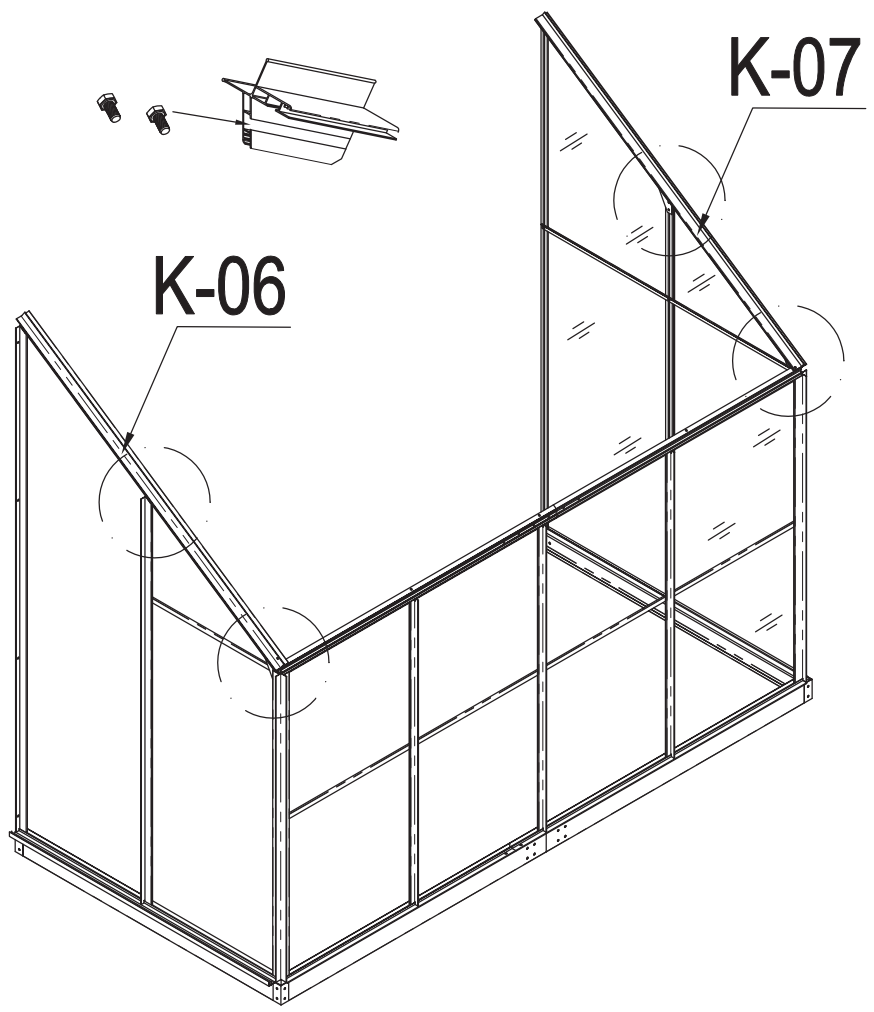

K-07

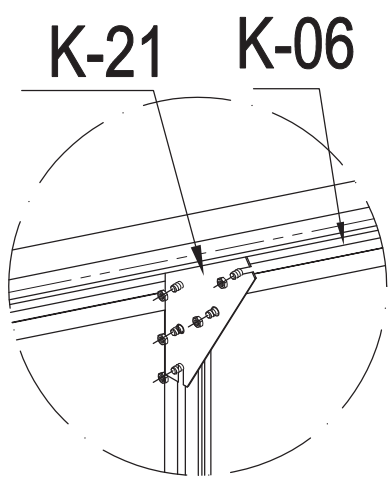

K-21

K-06

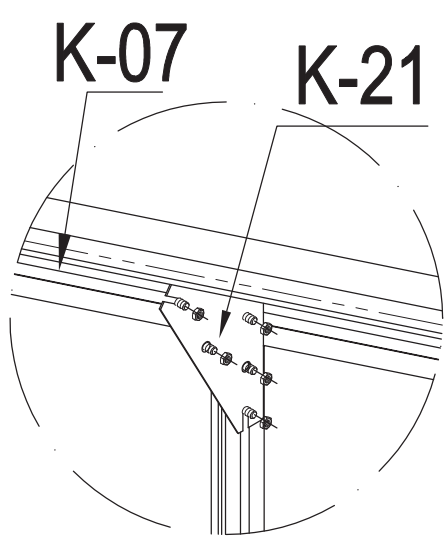

K-07

K-21

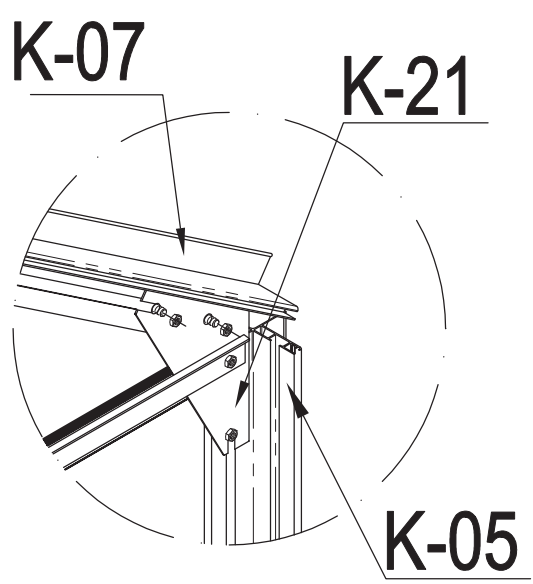



K-07

K-21

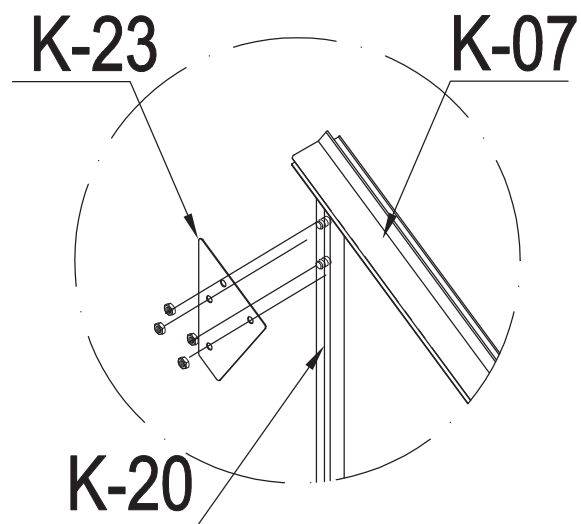
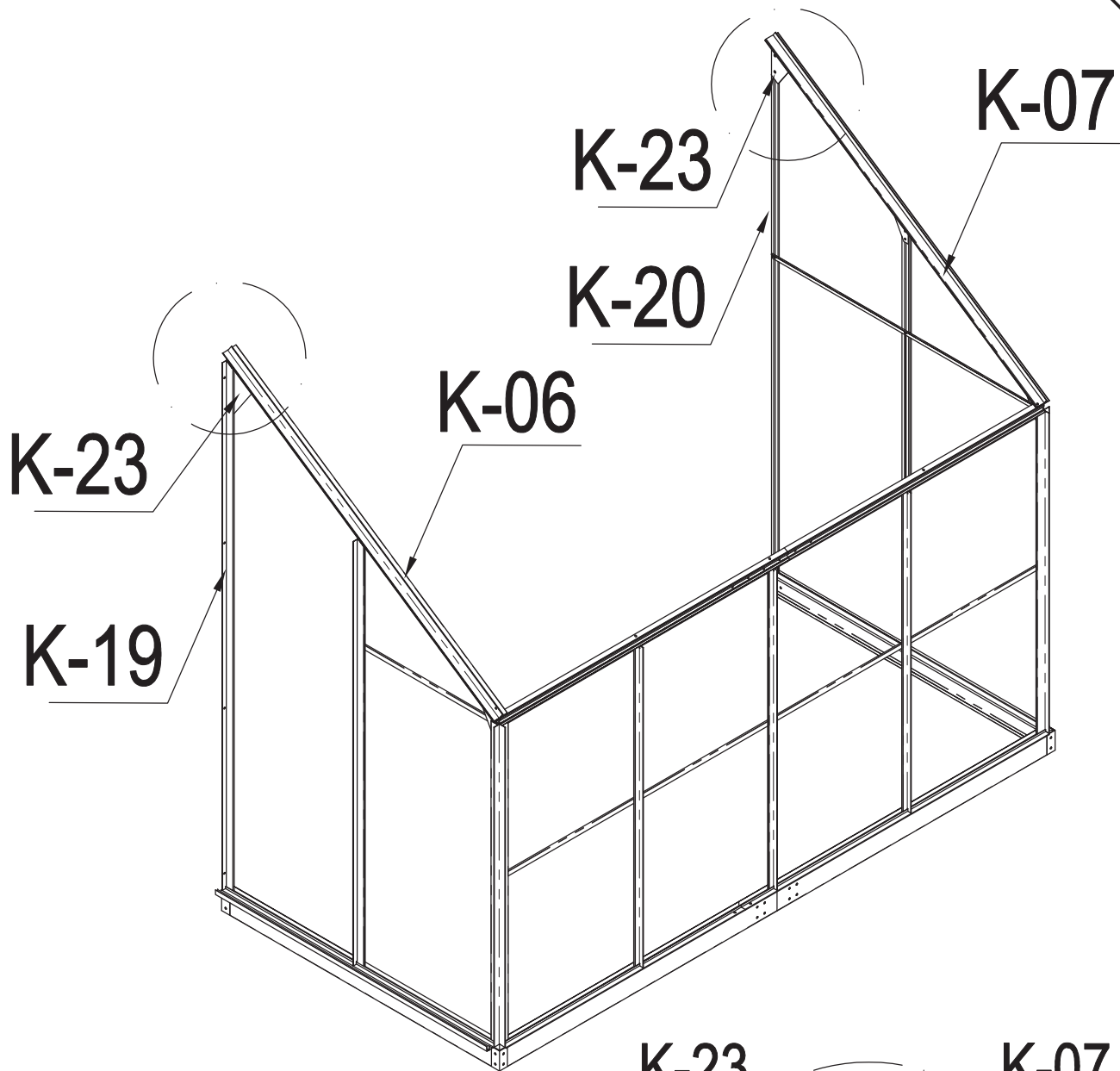

K-05

|  |       |    |
|--|-------|----|
|  | K-06  | 1  |
|  | K-07  | 1  |
|  | K-21  | 2  |
|  | K-B31 | 12 |
|  | K-B31 | 12 |



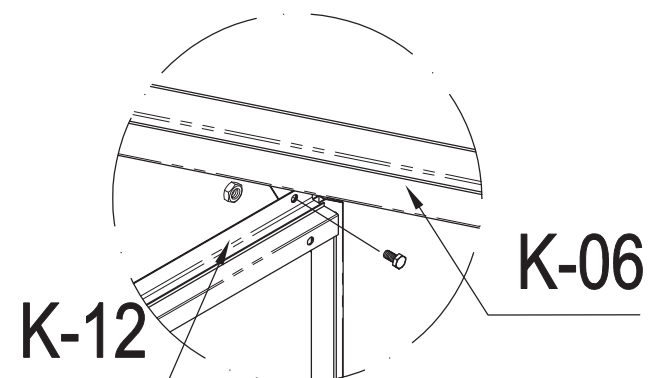
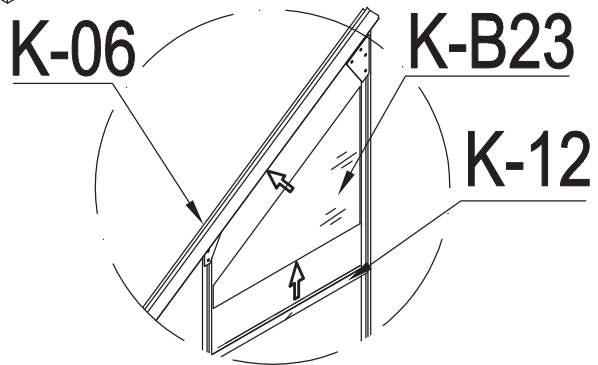
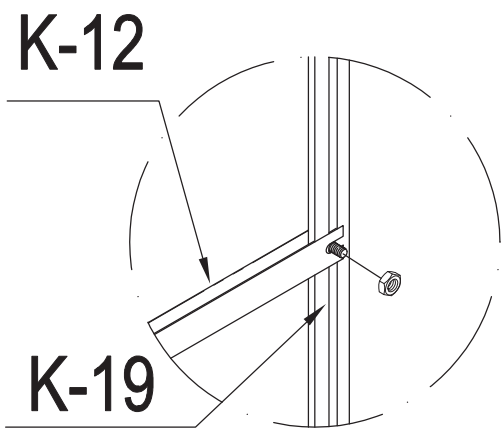
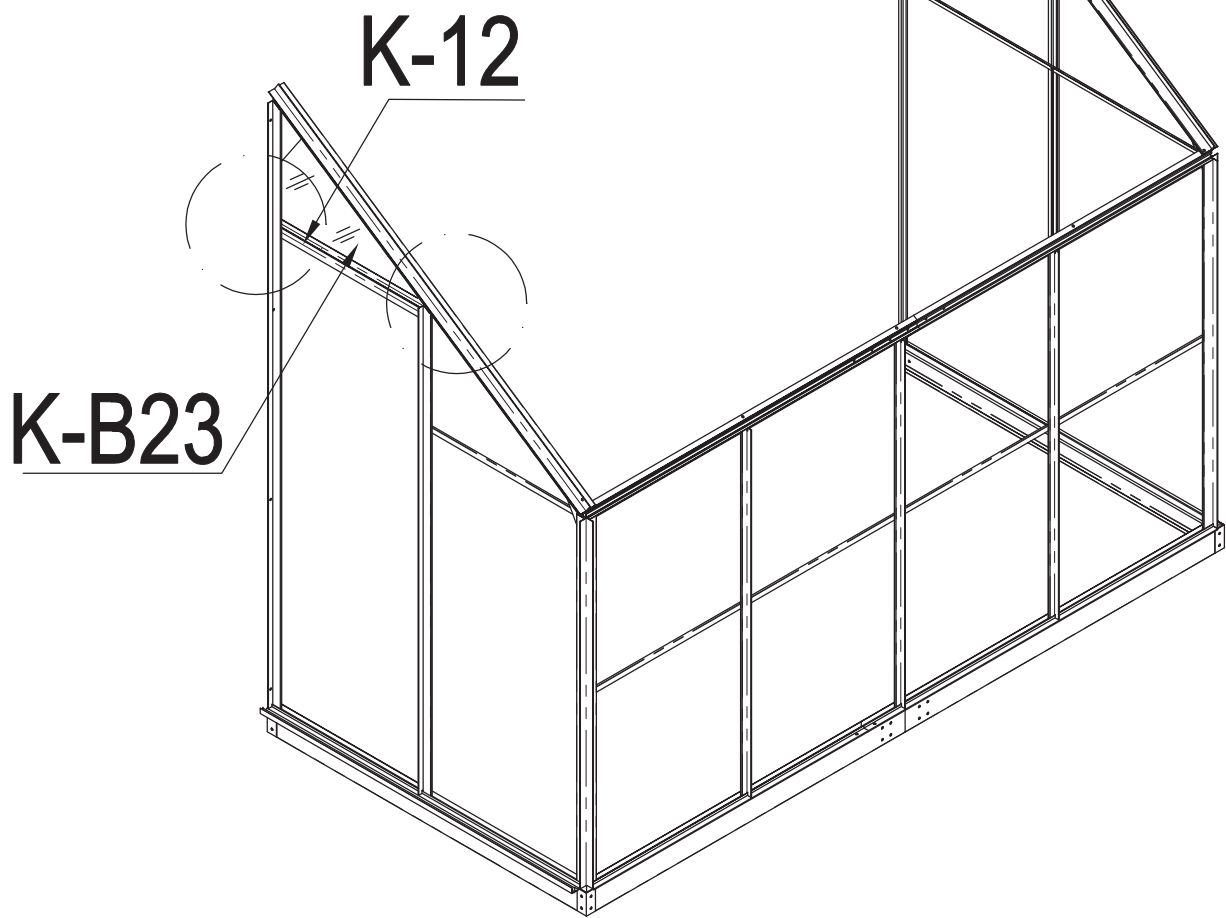



|   |       |   |
|---|-------|---|
|  | K-23  | 2 |
|  | K-B31 | 8 |



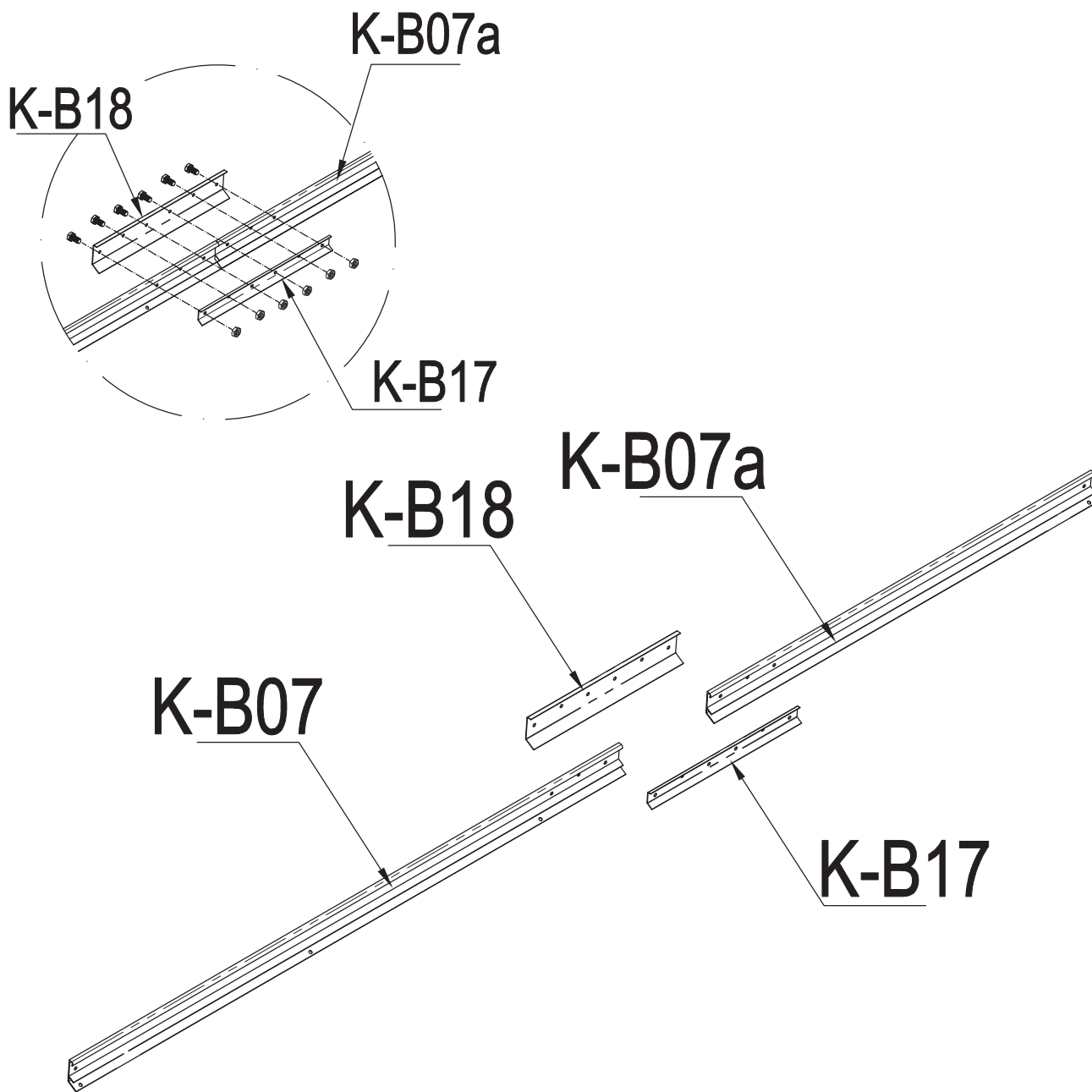

|   |       |   |
|---|-------|---|
|  | K-12  | 1 |
|  | K-B31 | 1 |
|  | K-B31 | 2 |





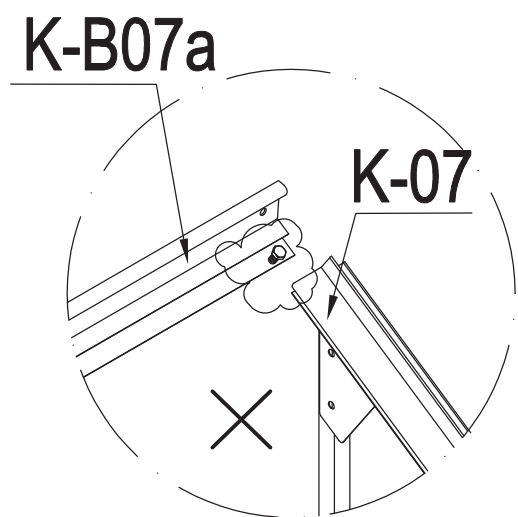
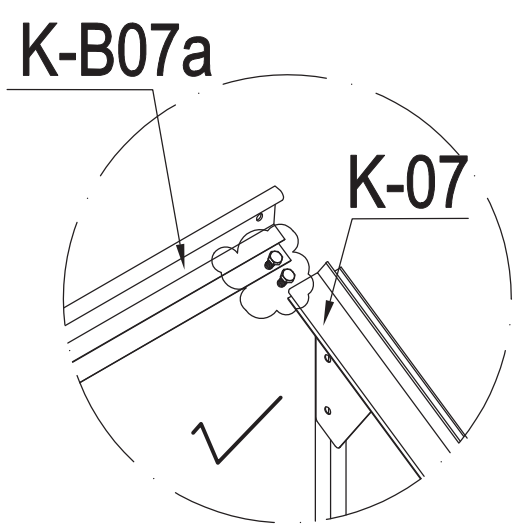
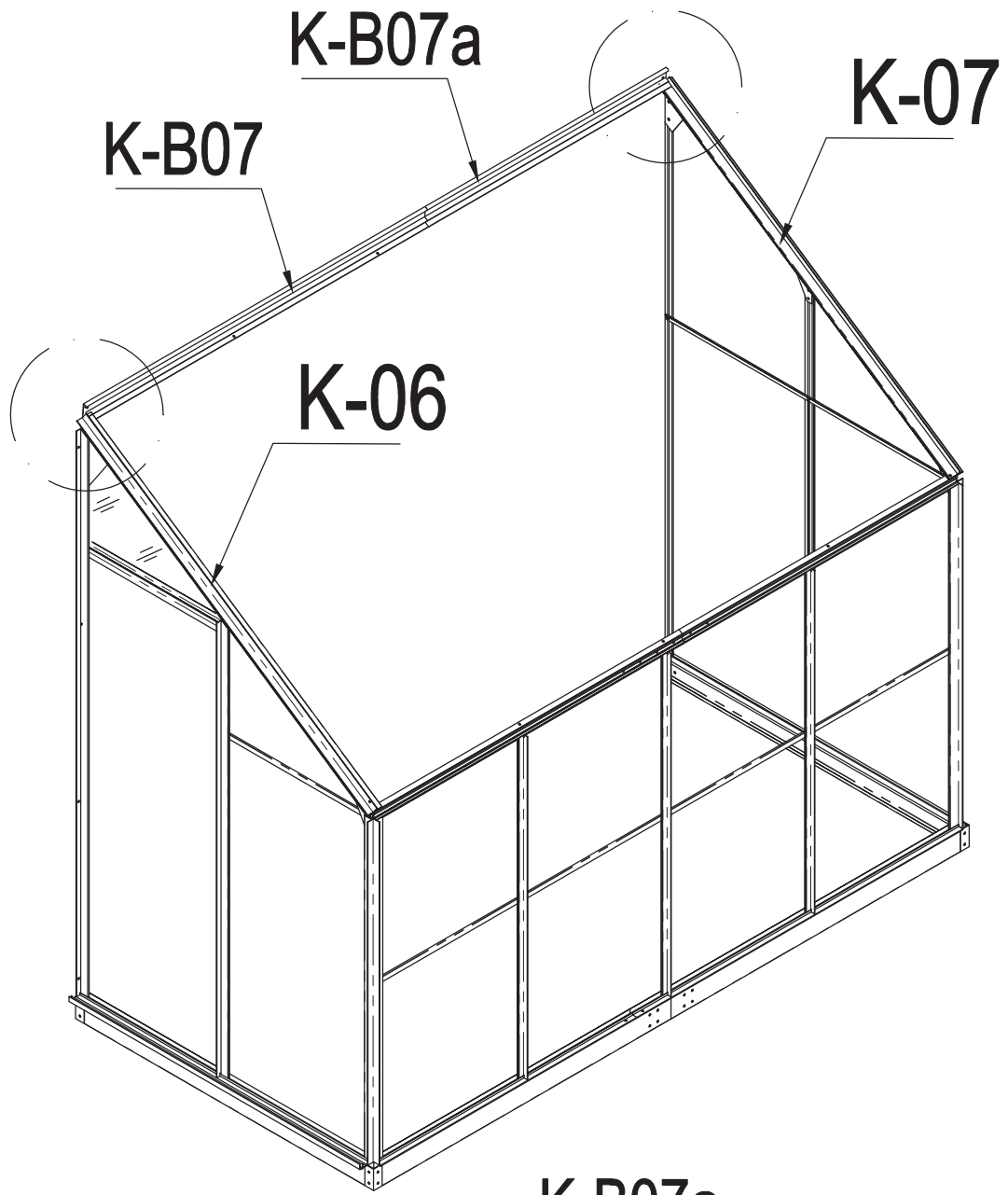

|   |       |   |
|---|-------|---|
|  | K-B17 | 1 |
|  | K-B18 | 1 |
|  | K-B31 | 6 |

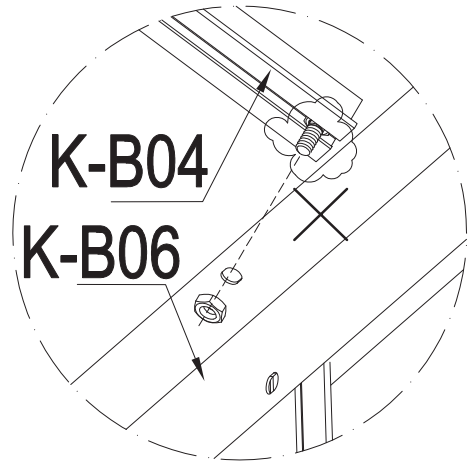
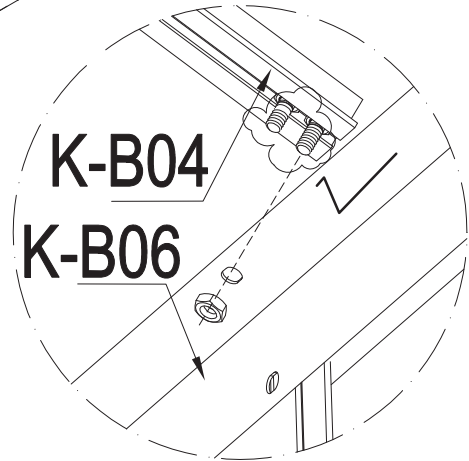
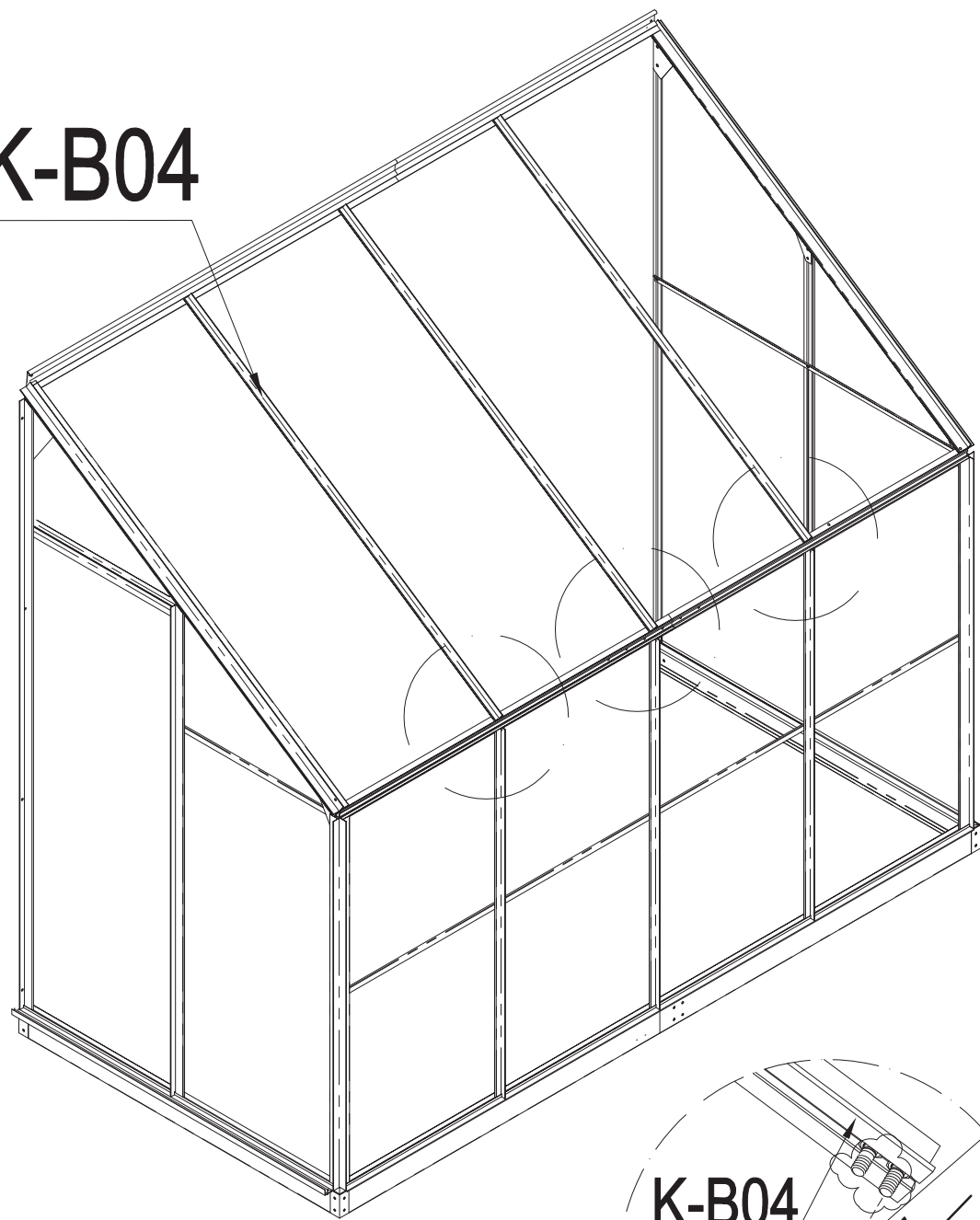

|   |       |   |
|---|-------|---|
|  | K-B31 | 4 |
|  | K-B31 | 2 |

K-B04



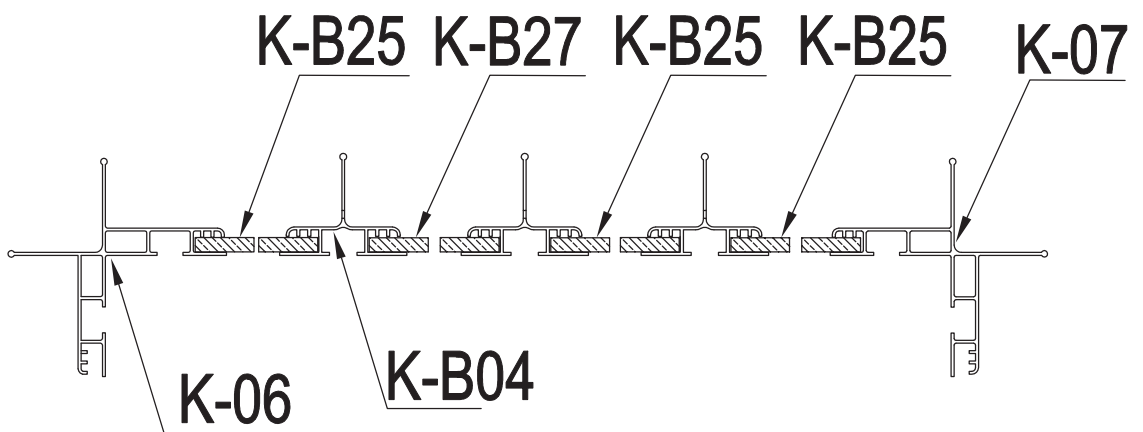
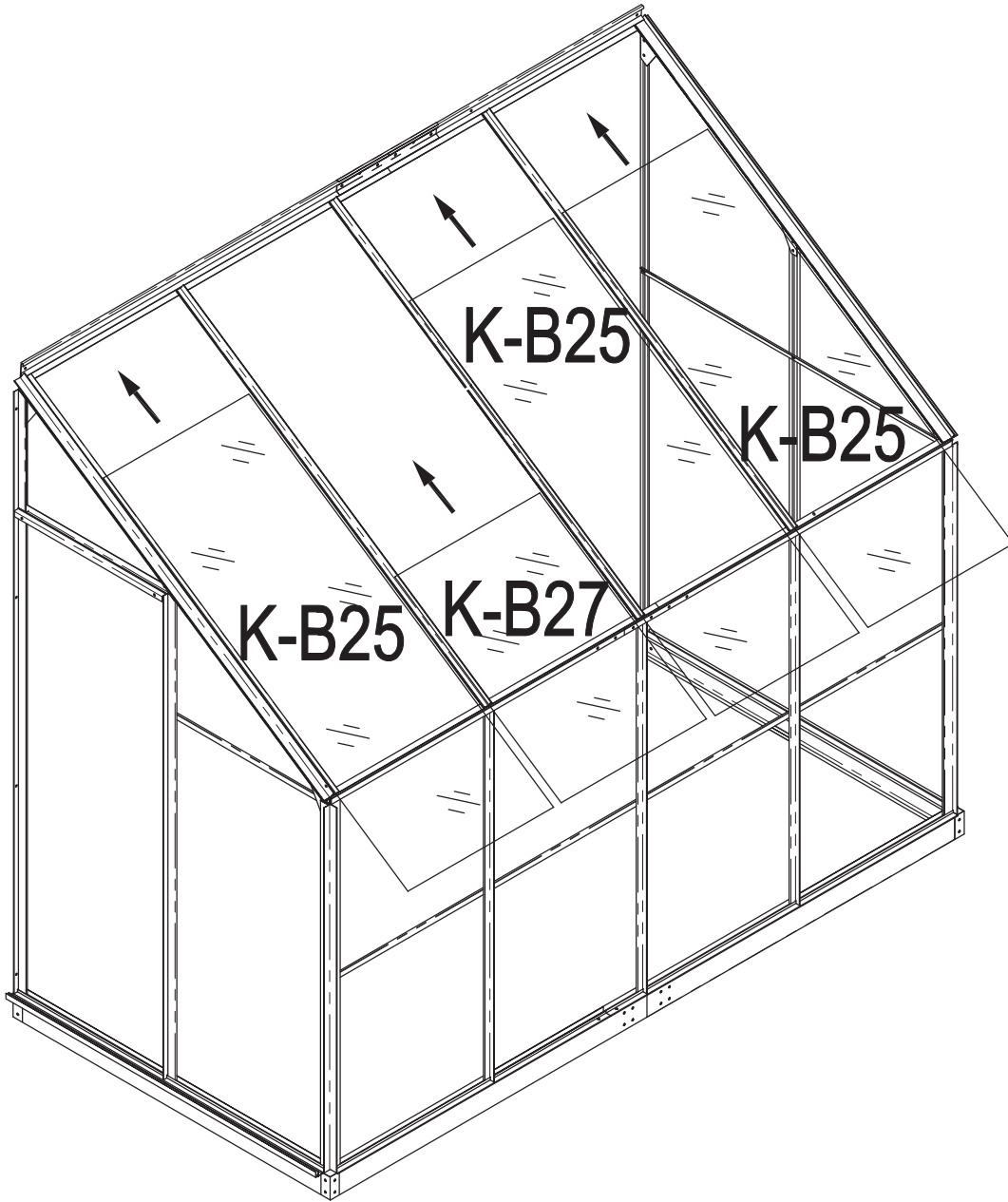

|   |       |   |
|---|-------|---|
|  | K-B04 | 3 |
|  | K-B31 | 9 |
|  | K-B31 | 6 |

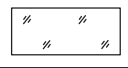
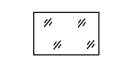

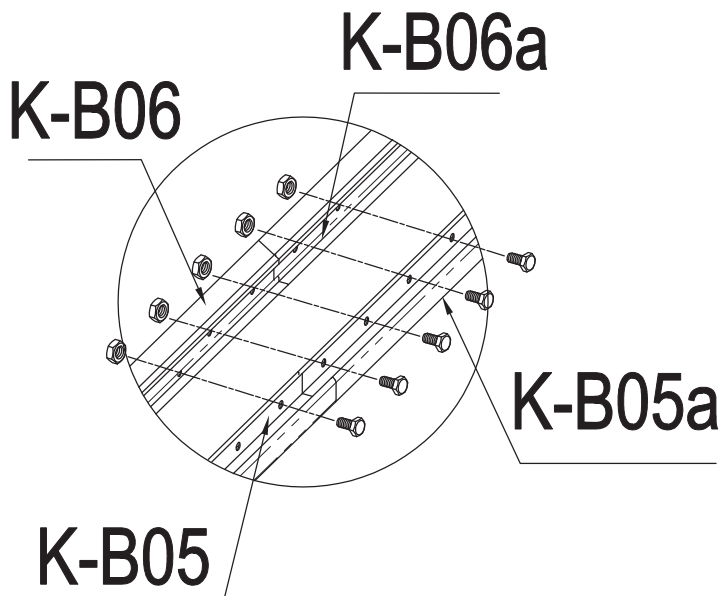
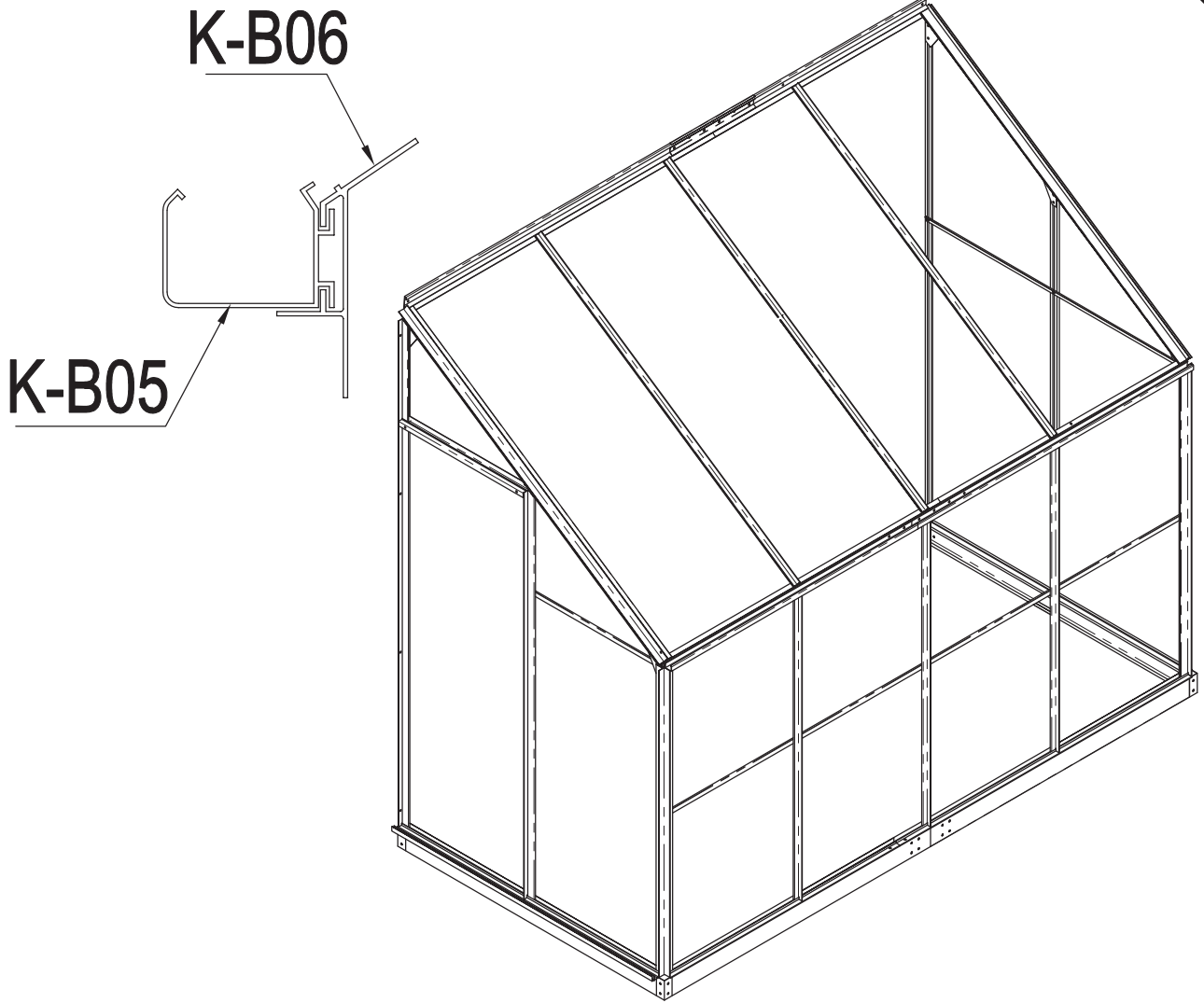
|   |       |   |
|---|-------|---|
|  | K-B25 | 3 |
|  | K-B27 | 1 |



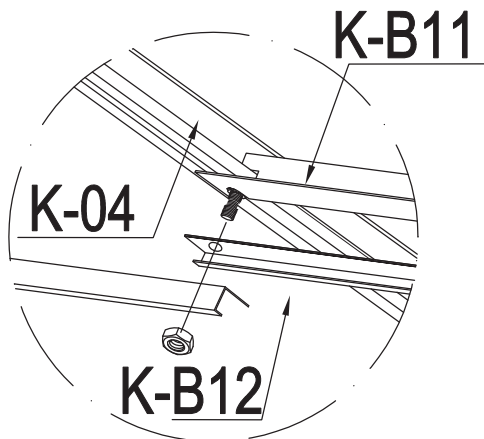
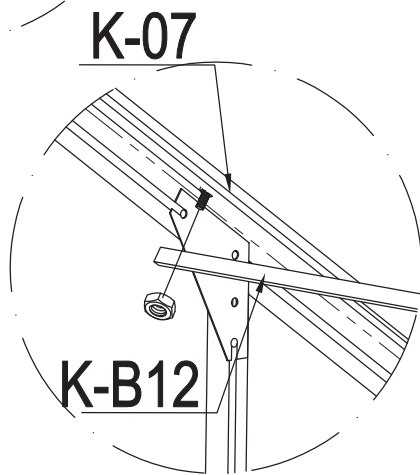
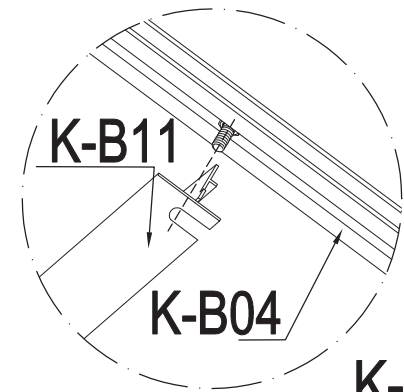
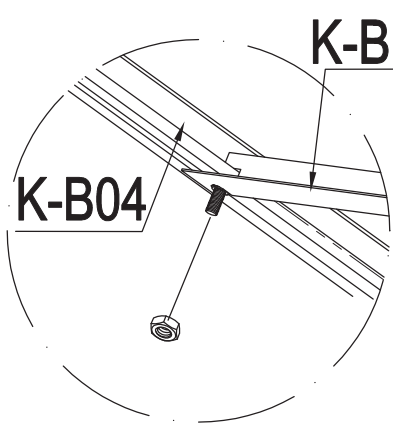
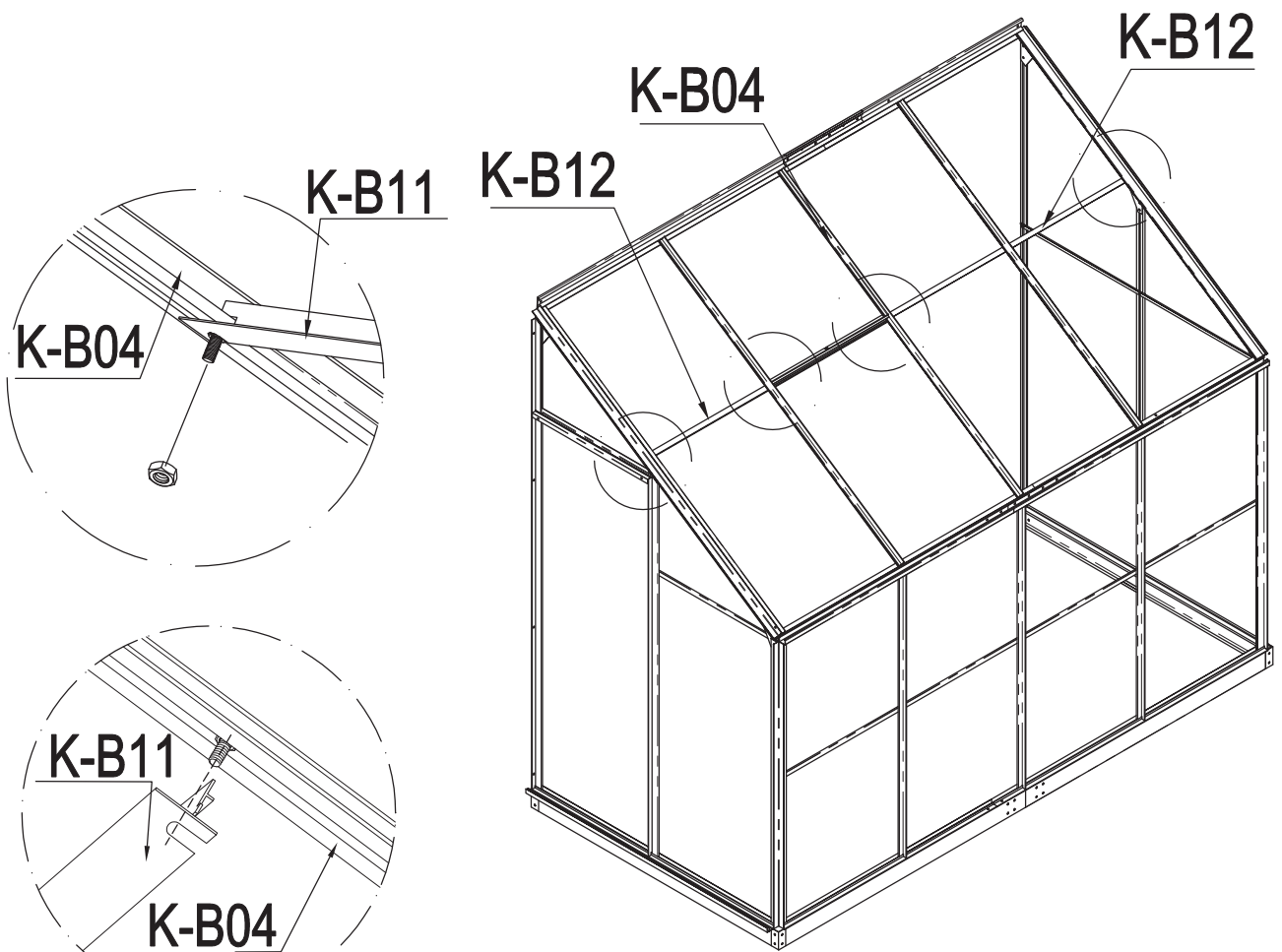

|   |        |   |
|---|--------|---|
|  | K-B05  | 1 |
|  | K-B05a | 1 |
|  | K-B31  | 6 |



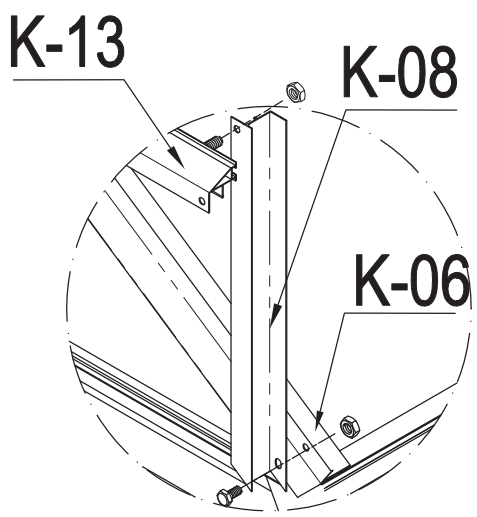
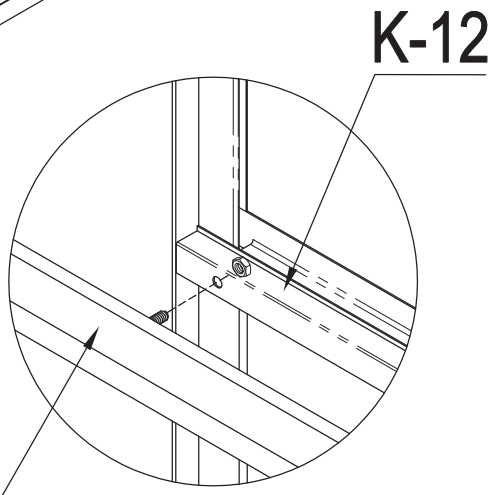
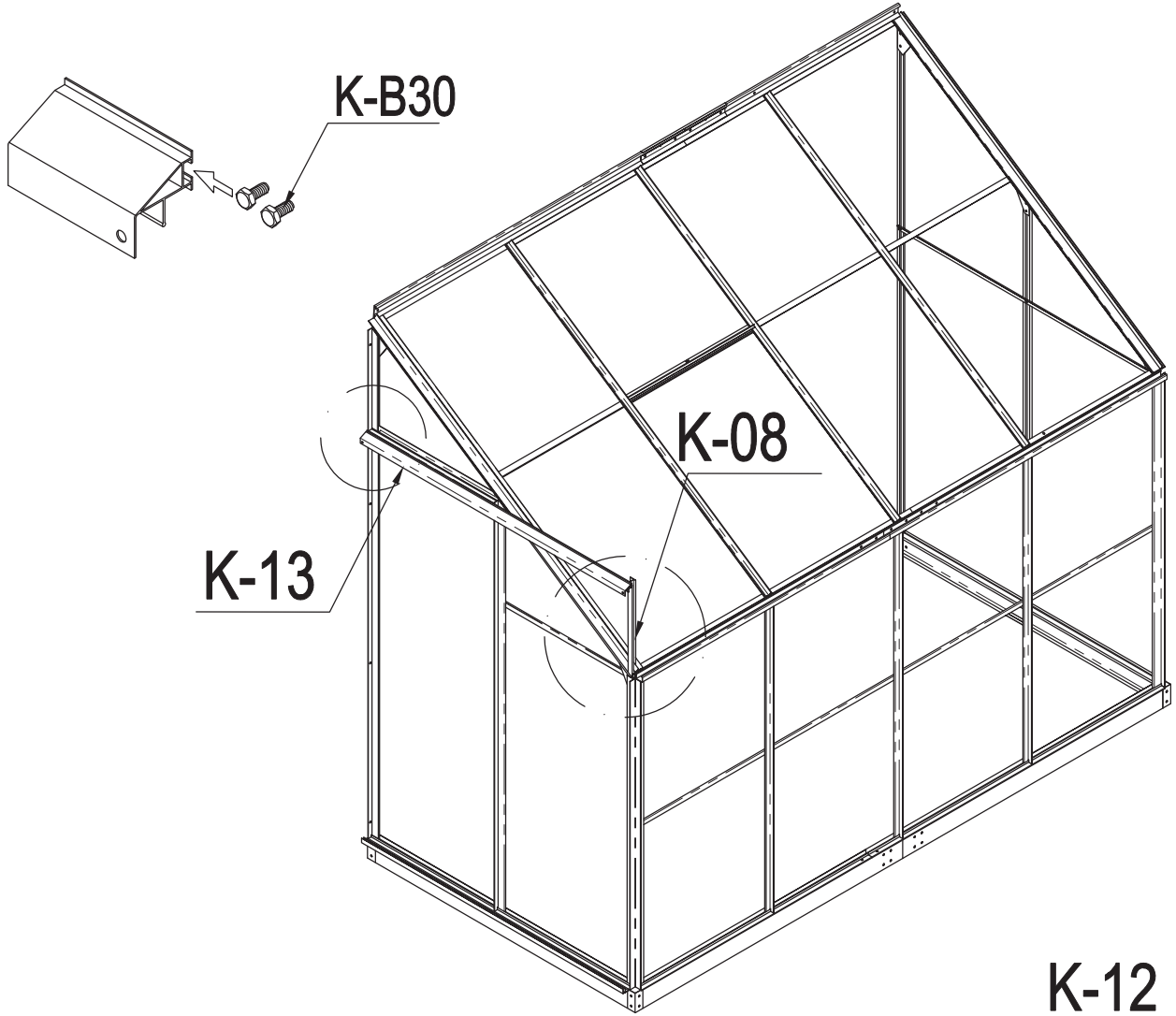

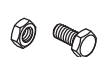

|   |       |   |
|---|-------|---|
|  | K-B11 | 1 |
|  | K-B12 | 2 |
|  | K-A31 | 5 |

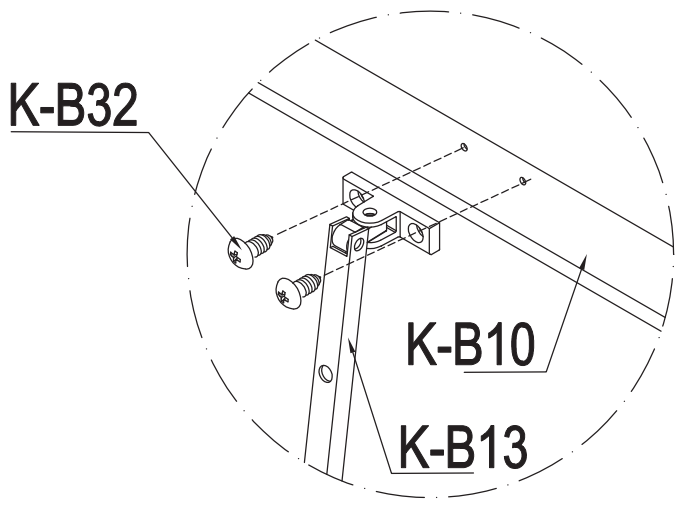
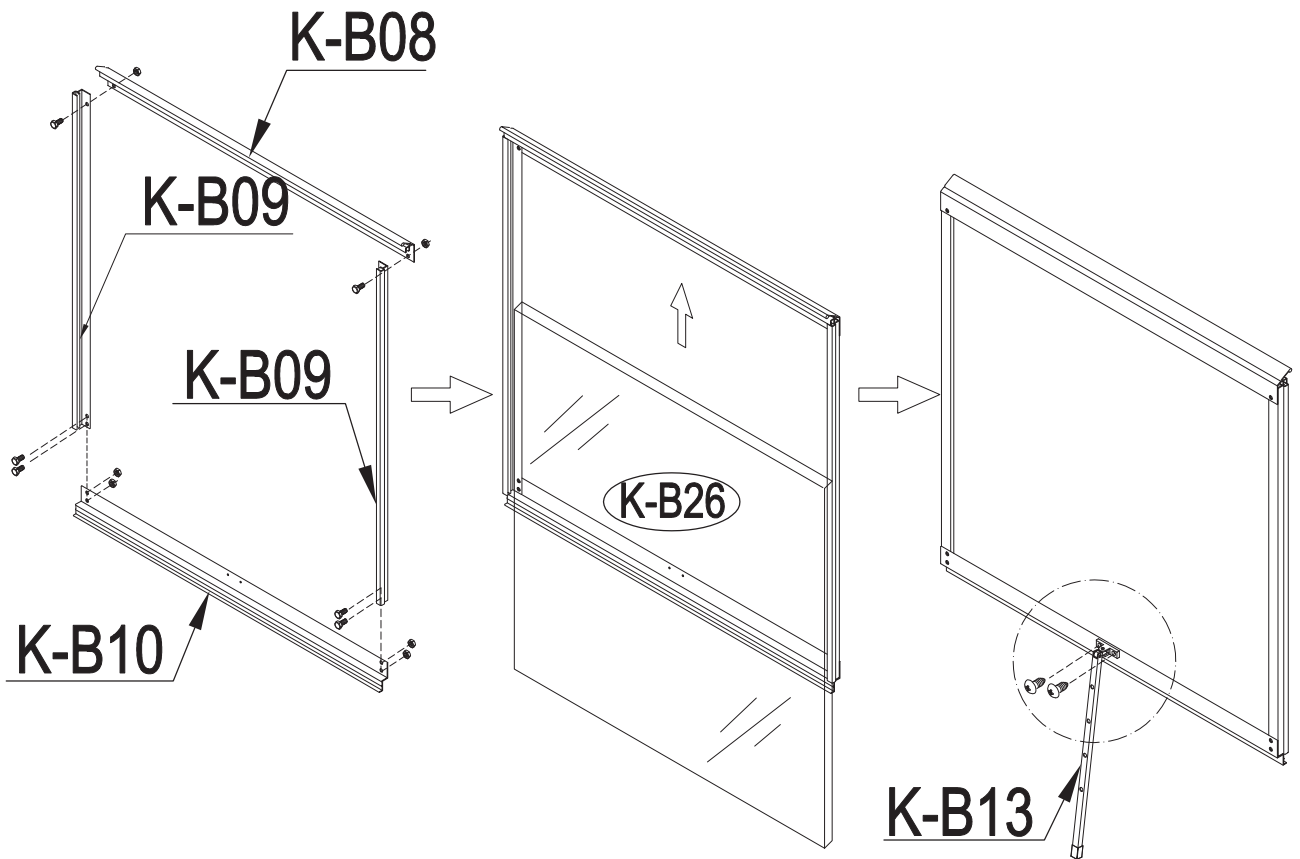

|   |       |   |
|---|-------|---|
|  | K-13  | 1 |
|  | K-08  | 1 |
|  | K-B31 | 4 |

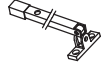

|   |       |   |
|---|-------|---|
|  | K-B08 | 1 |
|  | K-B09 | 2 |
|  | K-B10 | 1 |
|  | K-B13 | 1 |
|  | K-B32 | 2 |
|  | K-B31 | 6 |



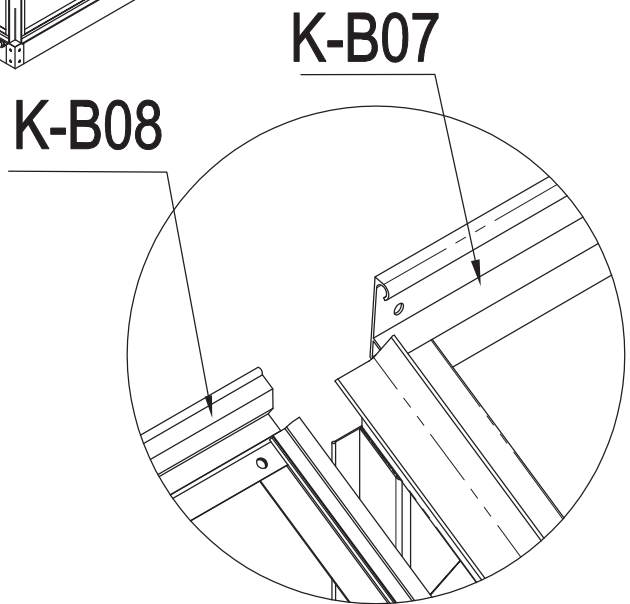
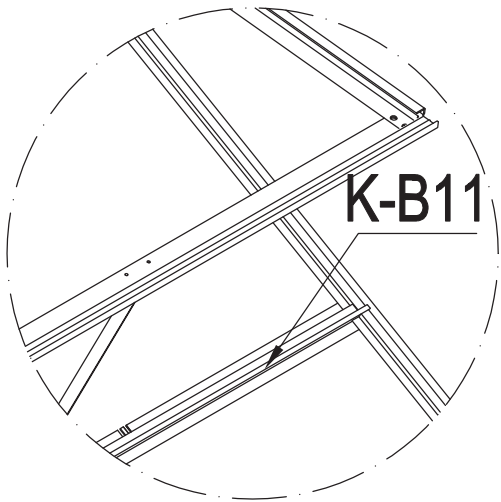
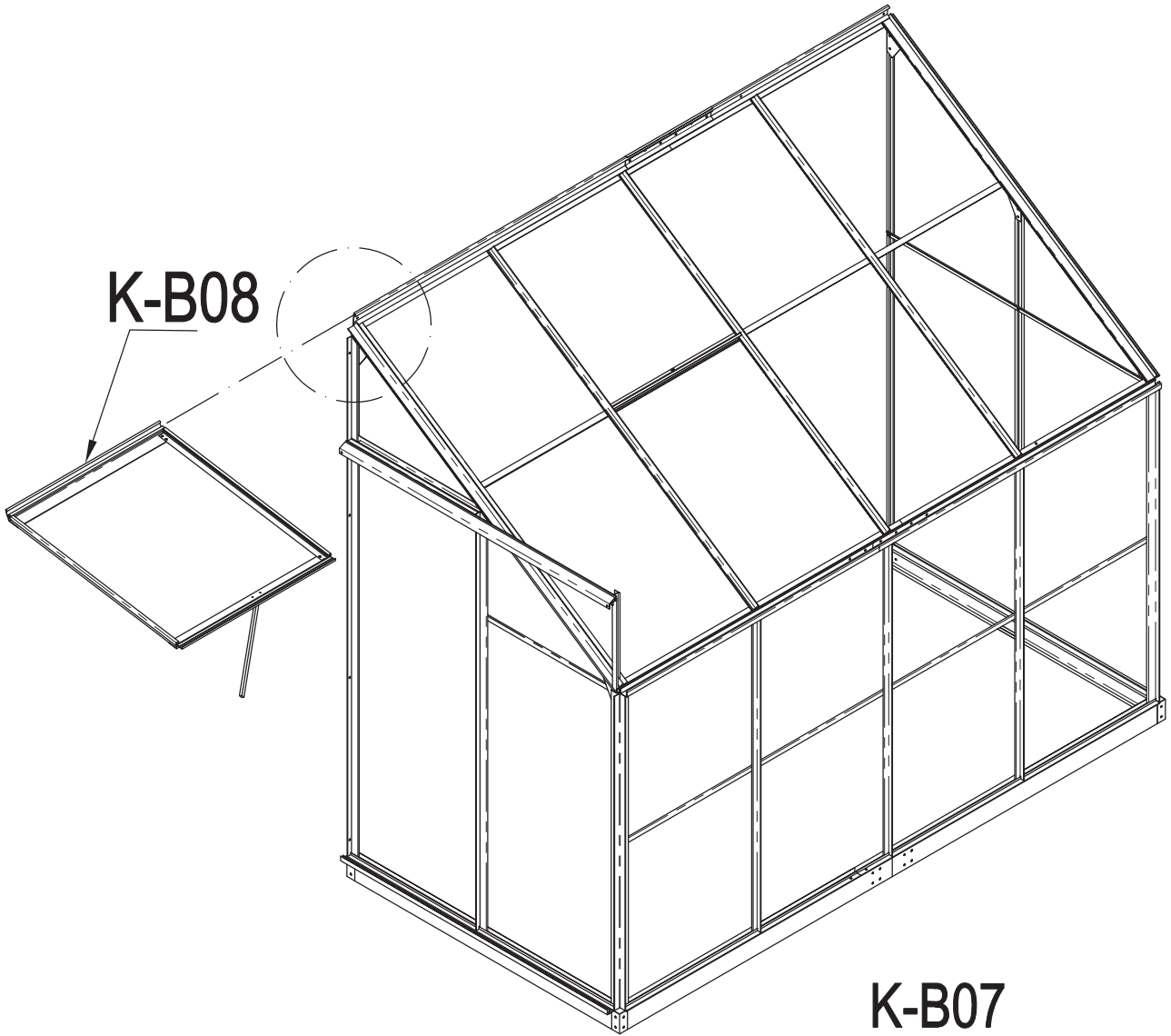



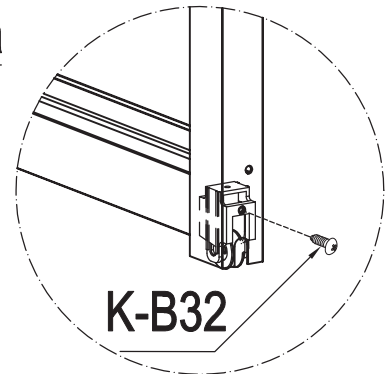
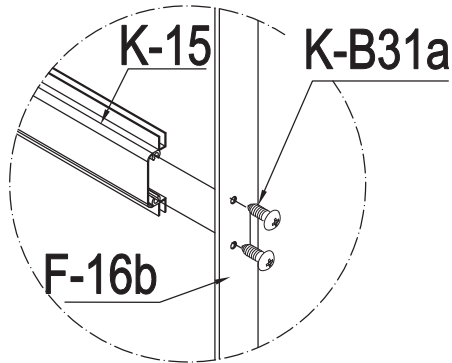
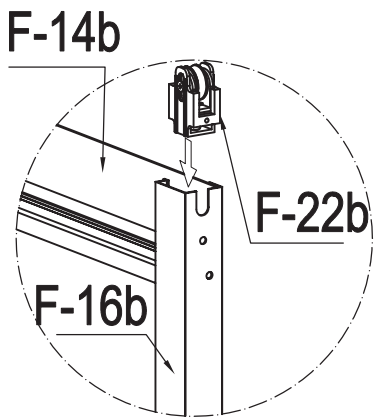
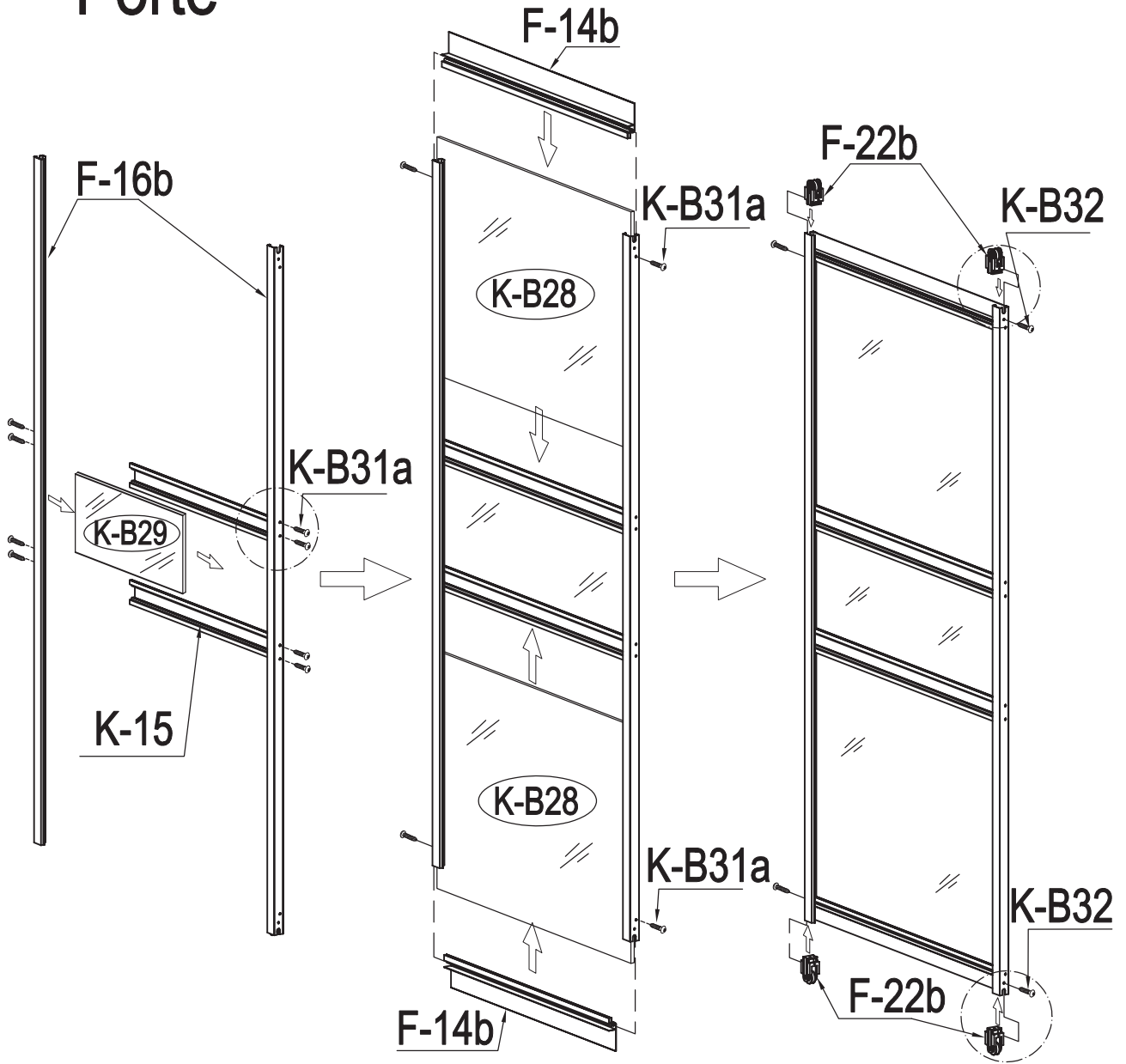

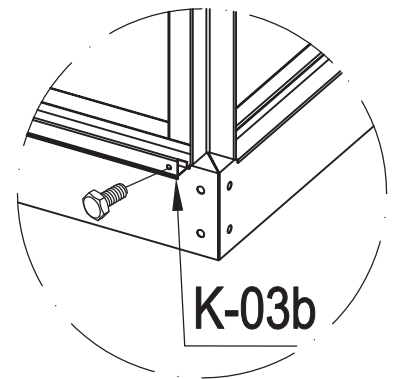
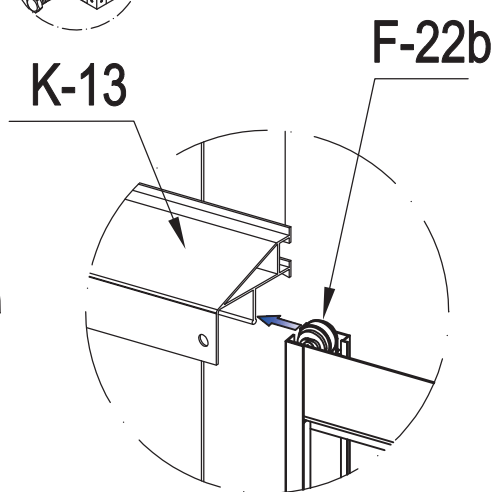
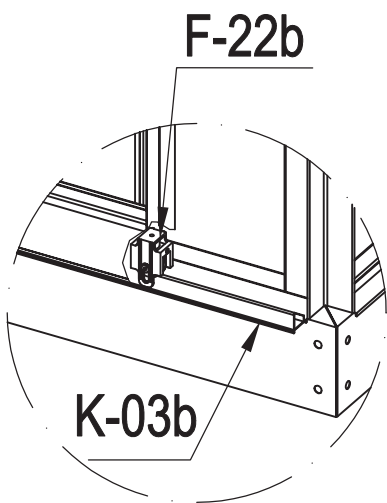
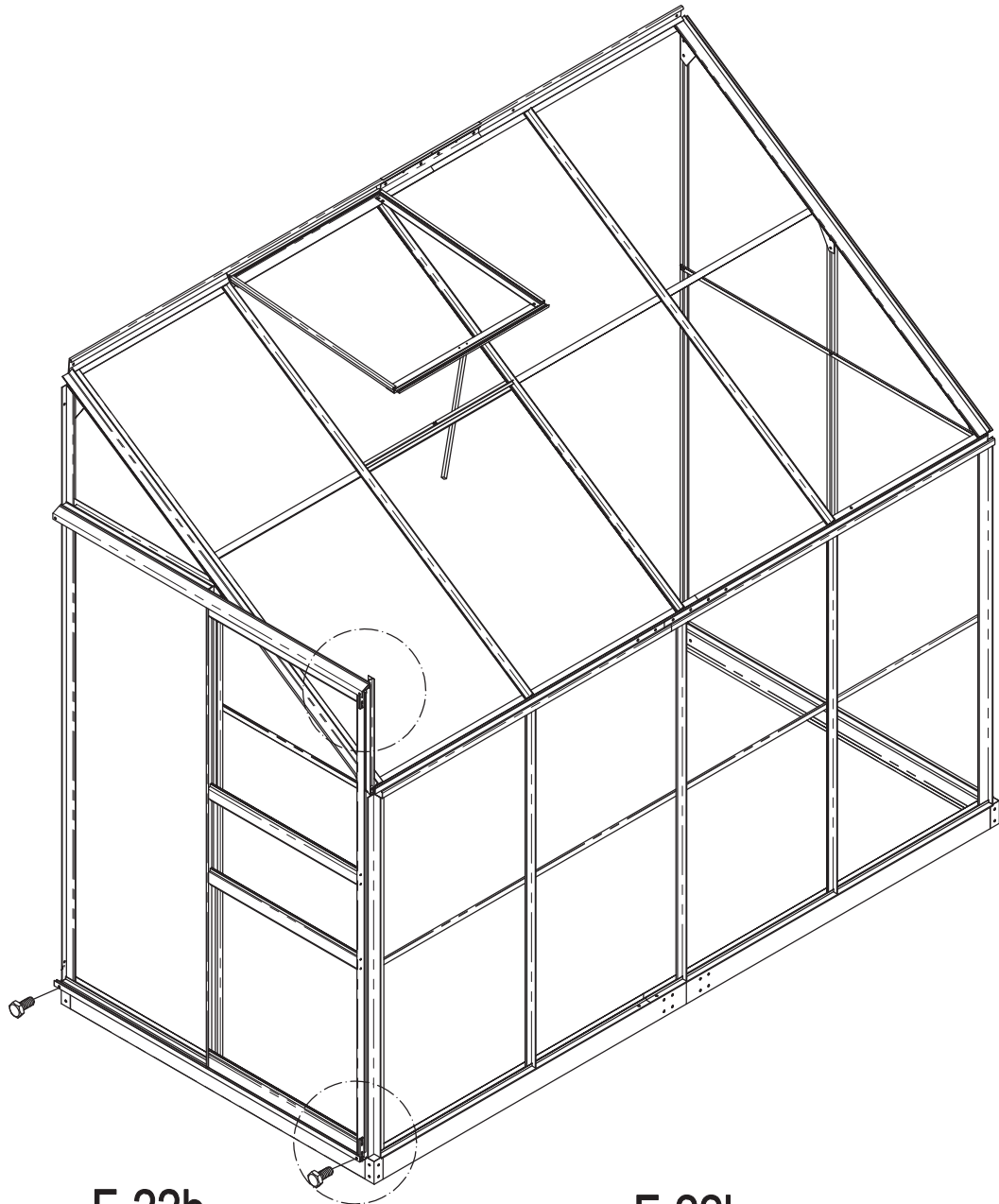
# Porte



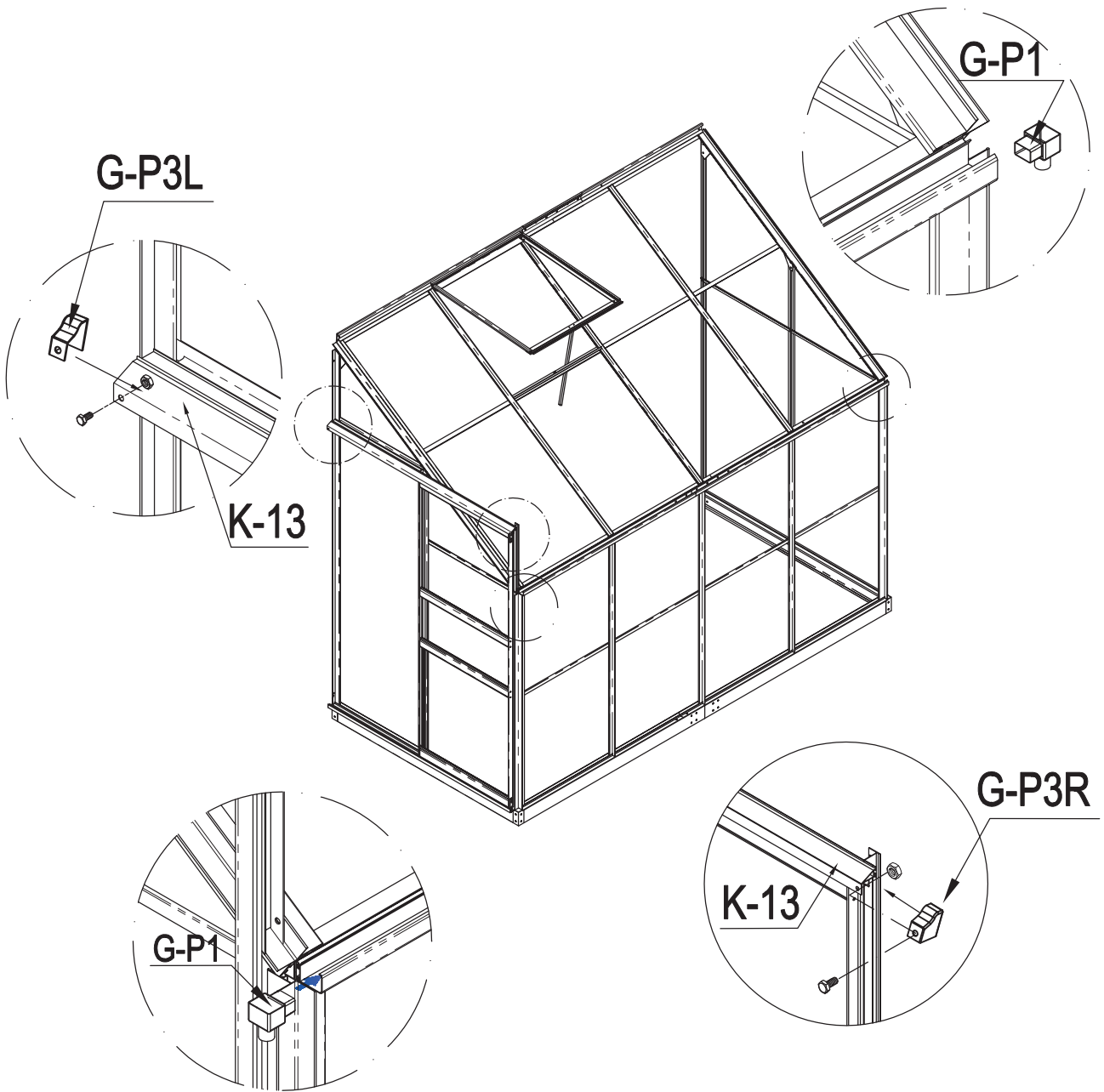

|   |       |   |
|---|-------|---|
|  | K-B31 | 2 |
|---|-------|---|



|   |       |   |
|---|-------|---|
|  | G-P3L | 1 |
|  | G-P1  | 2 |
|  | G-P3R | 1 |
|  | K-B31 | 2 |

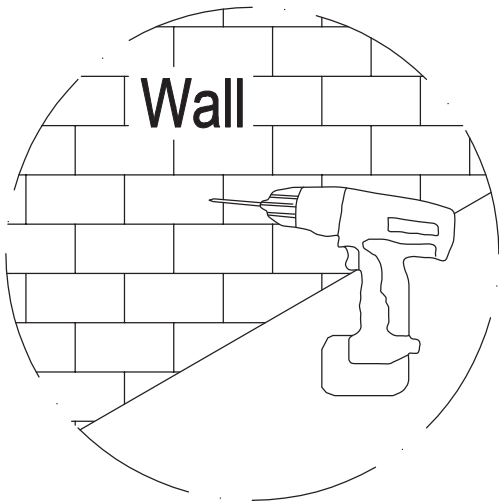
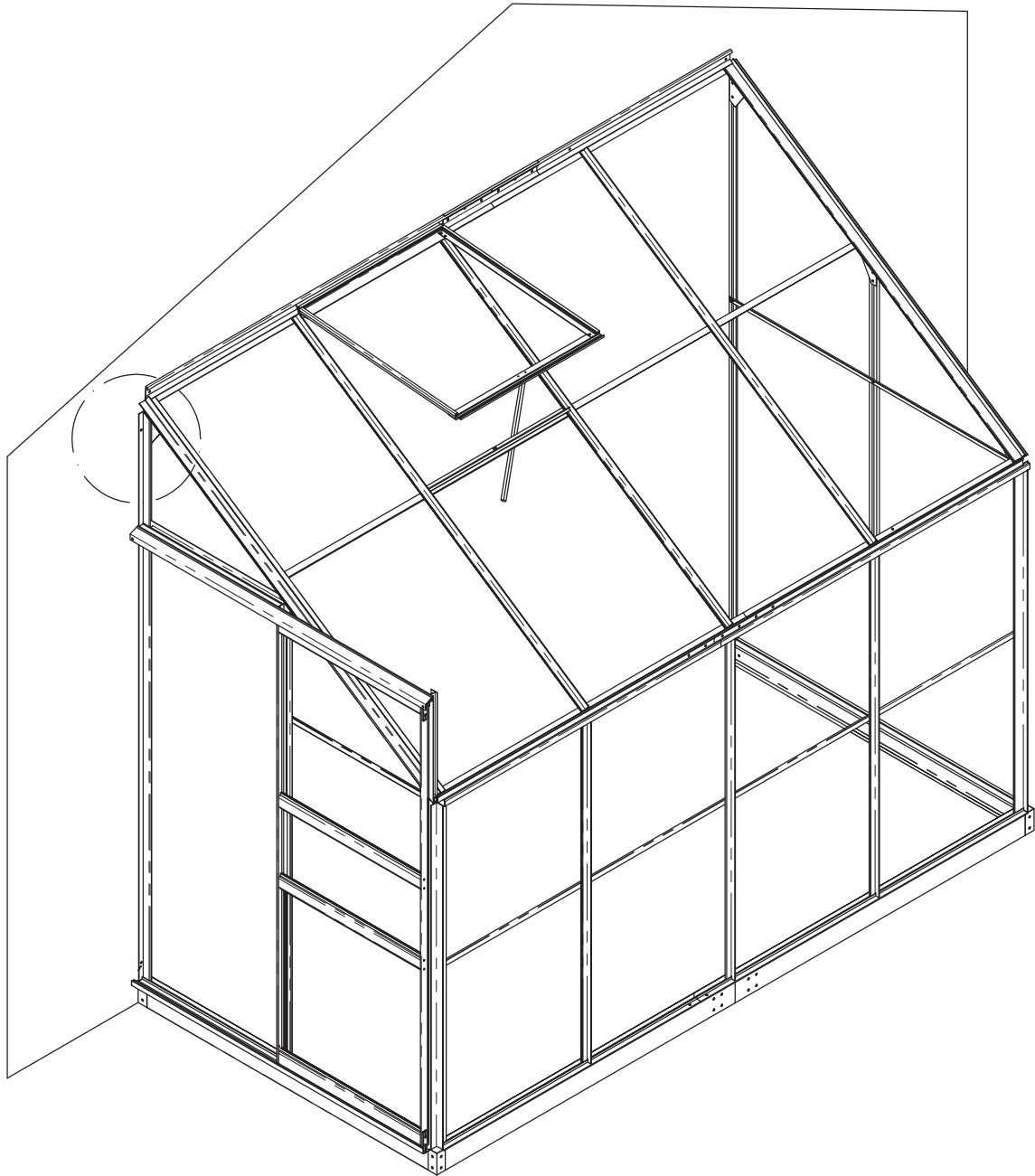

K-B19

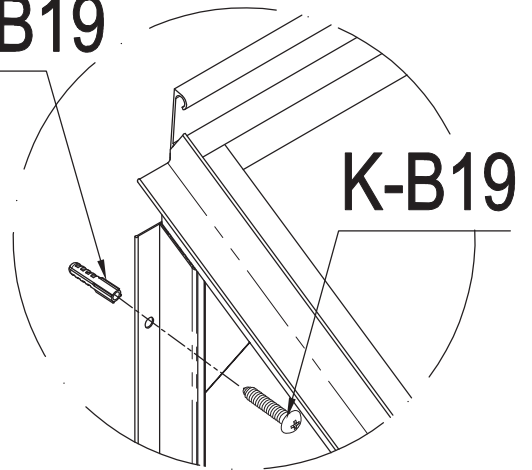

|   |       |    |
|---|-------|----|
|  | K-B19 | 12 |
|---|-------|----|

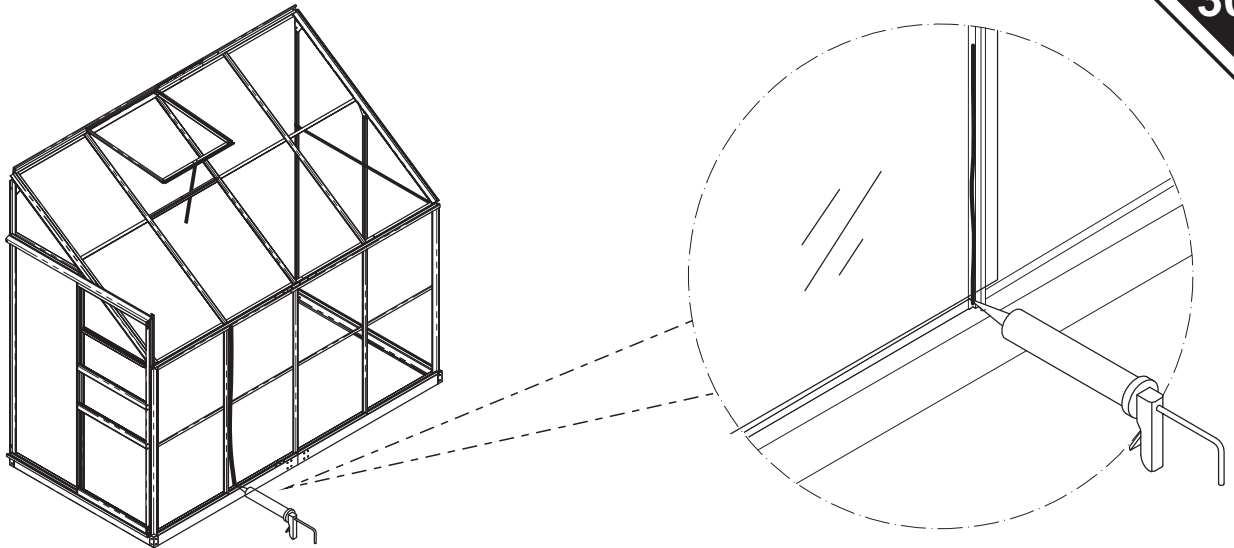
**ADVICE**

EN

It is not necessary but we would advise: For additional strength, you can also use some glue or tapes between the polycarbonate panel and the aluminium frame to enhance the stability.  
 Note: Silicone sealant and glue gun are not included in our tool kit. You can buy them locally. Only use silicone sealant suitable for aluminium

**CONSEILS**

FR

Ce n'est pas nécessaire mais nous vous conseillons:  
 Pour plus de solidité, vous pouvez également utiliser de la colle ou des rubans adhésifs entre le panneau en polycarbonate et le cadre en aluminium pour améliorer la stabilité.  
 Not : Le mastic silicone et le pistolet à colle ne sont pas inclus dans notre kit d'outils. Vous pouvez les acheter sur place. N'utilisez que du mastic silicone adapté à l'aluminium

**CONSEJO**

ES

No es necesario, pero le aconsejamos: Para mayor resistencia, también puede usar pegamento o cintas entre el panel de policarbonato y el marco de aluminio para mejorar la estabilidad.  
 Nota: El sellador de silicona y la pistola de pegamento no están incluidos en nuestro kit de herramientas. Puede comprarlos localmente. Sólo utilice el sellador de silicona adecuado para aluminio

**RAT**

DE

Es ist nicht notwendig, aber wir würden vorschlagen: Um die Festigkeit zu erhöhen, können Sie auch etwas Kleber oder Klebeband zwischen der Polycarbonatplatte und dem Aluminiumrahmen verwenden, um die Stabilität zu verbessern.  
 Hinweis: Silikondichtmittel und Klebepistole sind nicht in unserem Werkzeugsatz enthalten. Sie können sie vor Ort kaufen. Verwenden Sie nur für Aluminium geeignetes Silikondichtmittel

**SUGGERIMENTI**

IT

Non è necessario ma consigliamo: Per una maggiore resistenza, puoi anche usare della colla o dei nastri tra il pannello in polycarbonato e la struttura in alluminio per migliorare la stabilità.  
 Nota: il sigillante siliconico e la pistola per colla non sono inclusi nel nostro kit di attrezzi. Puoi acquistarli localmente. Utilizzare solo sigillante siliconico adatto per alluminio.

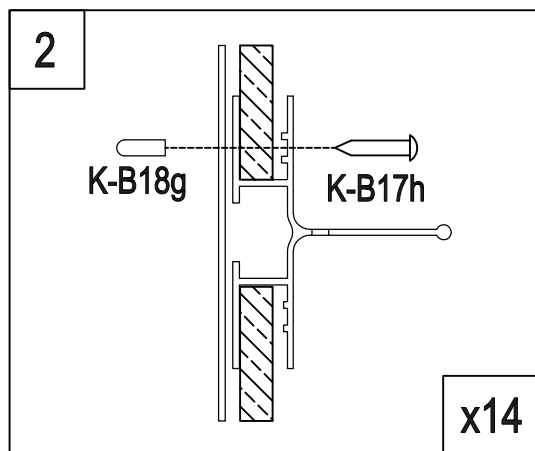
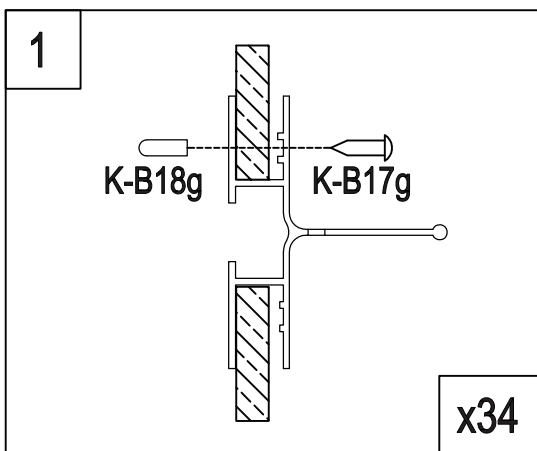
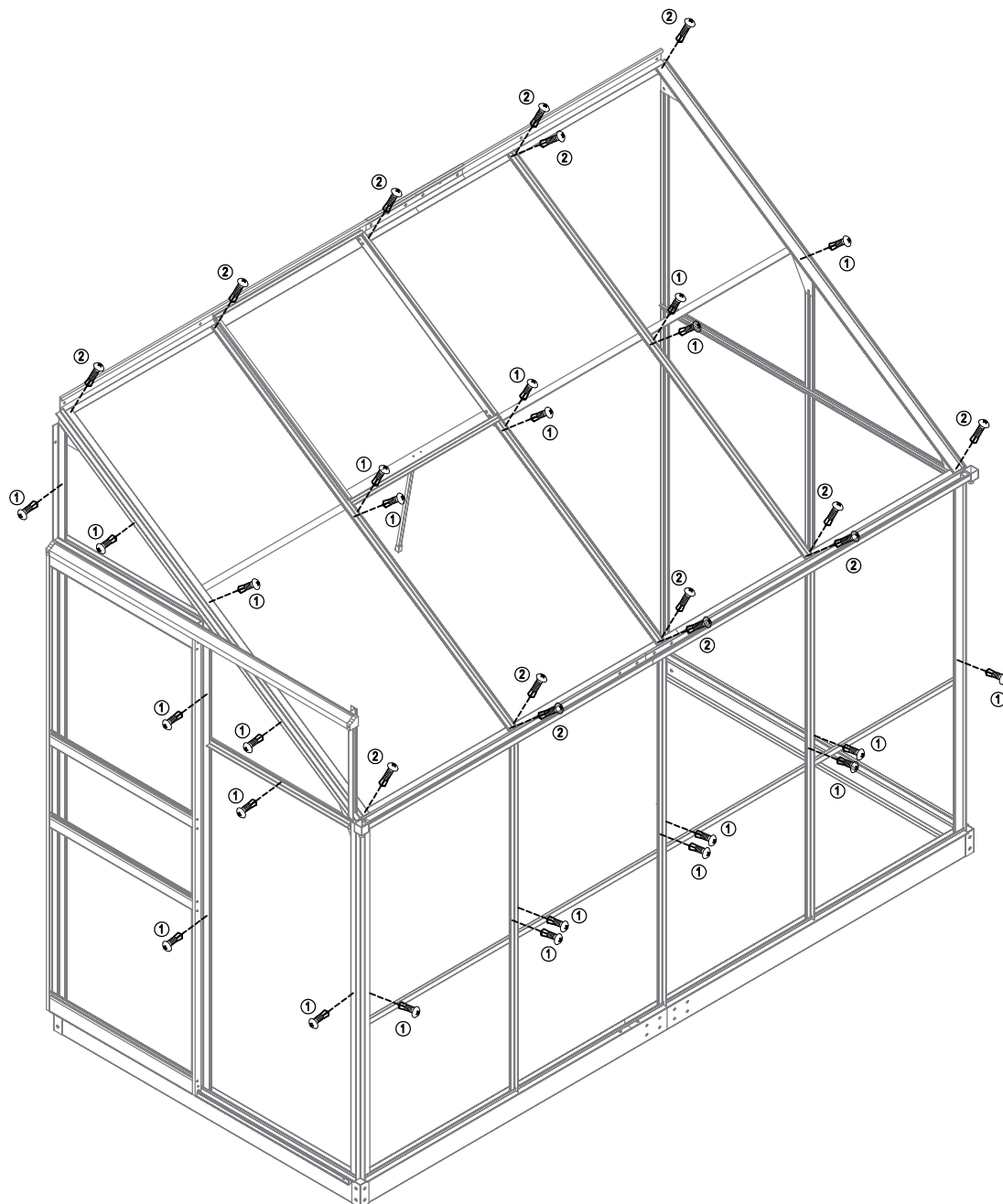

|   |        |    |
|---|--------|----|
|  | K-B17g | 34 |
|  | K-B17h | 14 |
|  | K-B18g | 48 |



EN

It is not necessary but we would advise:  
For additional strength, especially in the area with the strong wind weather, you can also drill the screws between the polycarbonate and the aluminum frame to enhance the stability.

Note: The screws are included in our tool kit.

FR

Ce n'est pas nécessaire mais nous vous conseillons:  
Pour plus de solidité, en particulier dans les zones où le vent est fort, vous pouvez également percer les vis entre le polycarbonate et le cadre en aluminium pour améliorer la stabilité.

Note: Les vis sont incluses dans notre kit d'outils.

ES

No es necesario, pero le aconsejamos:  
Para mayor resistencia, especialmente en el área con viento fuerte, también puede perforar los tornillos entre el policarbonato y el marco de aluminio para mejorar la estabilidad.

Nota: Los tornillos están incluidos en nuestro kit de herramientas.

DE

Es ist nicht notwendig, aber wir würden vorschlagen:  
Um die Festigkeit zu erhöhen, insbesondere in Gebieten mit starkem Wind, können Sie auch die Schrauben zwischen dem Polycarbonat und dem Aluminiumrahmen bohren, um die Stabilität zu verbessern.

Hinweis: Die Schrauben sind in unserem Werkzeugsatz enthalten.

IT

Non è necessario ma consigliamo:  
Per una maggiore resistenza, soprattutto nella zona con vento forte, potete forare e serrare le viti tra il policarbonato e la struttura in alluminio per migliorare la stabilità.

Nota: le viti sono incluse nel nostro kit di attrezzi.



US



001-877-644-9366  
customerservice@aosom.com

CA



001-855-537-6088  
customerservice@aosom.ca

UK



0044-800-240-4004  
enquiries@mhstar.co.uk

DE



0049-(0)40-88307530  
service@aosom.de

FR



0033-1-84166106  
contact@aosom.fr

ES



0034-931294512  
atencioncliente@aosom.es

IT



0039-0249471447  
clienti@aosom.it