

EN_ IMPORTANT, RETAIN FOR FUTURE REFERENCE: READ CAREFULLY.
FR_ IMPORTANT: A LIRE ATTENTIVEMENT ET À CONSERVER POUR CONSULTATION
ULTÉRIEURE.

ES_ IMPORTANTE, LEA Y GUARDE PARA FUTURAS REFERENCIAS.



DE_ „WICHTIG! SORGFÄLTIG LESEN UND FÜR SPÄTER NACHSCHLAGEN AUFBEWAHREN.“

IT_ IMPORTANTE! CONSERVARE IL PRESENTE MANUALE PER FUTURO RIFERIMENTO E
LEggerlo attentamente.

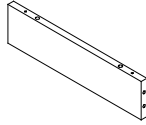
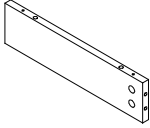
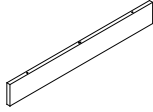
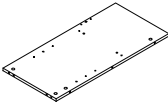
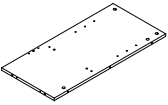
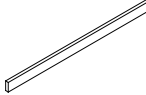
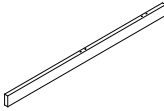
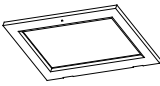

This product is packed in 2 outer boxes.
Please install it after all. Thank you!

PACKING DETAILS: TOTAL 2 BOXES

BOX-1/2

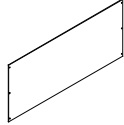
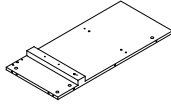
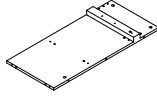
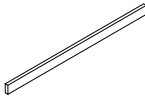
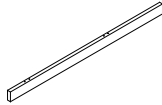
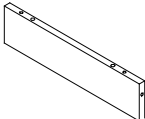
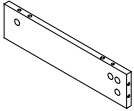
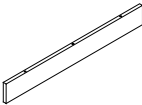
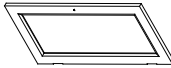
NO.	PARTS	QTY
2		x1
3		x1
4		x1
6		x1
7		x1
8		x1
9		x1
13		x1
14		x2

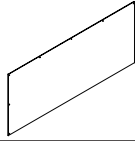
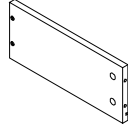
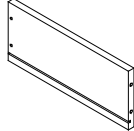
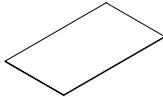
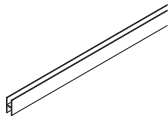
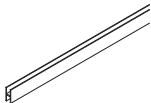
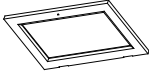
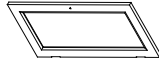
NO.	PARTS	QTY
15		x1
17		x1
18		x1
19		x1
20		x1
24		x1
25		x1
26		x1
27		x1

NO.	PARTS	QTY
28		x2
30		x1
31		x1
32		x1
34		x1
35		x1
36		x1
37		x1
		
<p>Hardware Kit</p>		

This product is packed in 2 outer boxes.
Please install it after all. Thank you!

PACKING DETAILS: TOTAL 2 BOXES

BOX-2/2

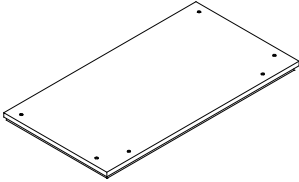
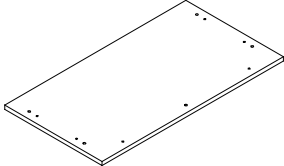
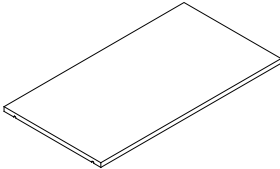
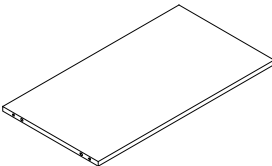
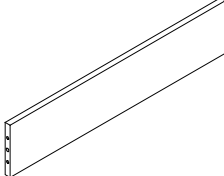
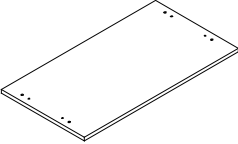
NO.	PARTS	QTY
1		x1
5		x1
10		x1
11		x2
12		x1
16		x1

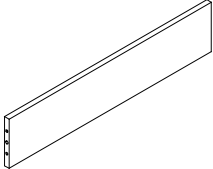
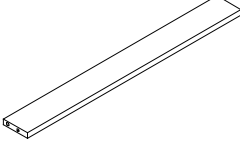
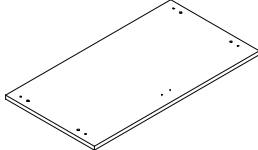
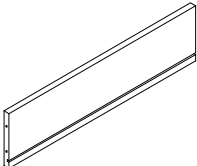
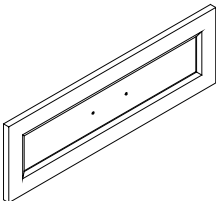
NO.	PARTS	QTY
21		x1
22		x1
23		x1
29		x1
33		x1

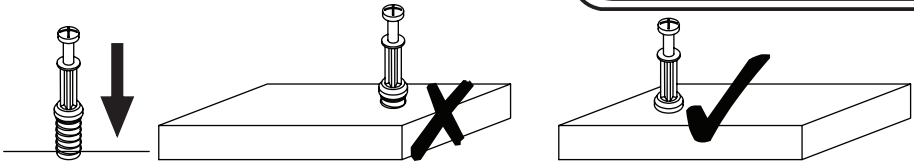

EN_ QUICKFIT: Tighten quickfit until shoulder is flush with panel. Do not overtighten or undertighten.

FR_ RACCORD RAPIDE: Faites serrer le raccord rapide jusqu'à ce que l'épaulement soit parfaitement encastré dans le panneau. Il ne faut ni trop serrer ni insuffisamment serrer.

ES_ QUICKFIT: Apriete quickfit hasta que el hombro se descargue con el panel. NO lo sobreapriete ni lo apriete poco.

DE_ QUICKFIT: Ziehen Sie den Quickfit fest, bis die Schulter mit der Platte bündig ist. Bitte nicht zu fest oder zu schwach anziehen.

IT_ MONTAGGIO RAPIDO: Stringere il montaggio rapido fino a quando la spalla è a filo con il pannello, non stringere troppo o troppo poco.

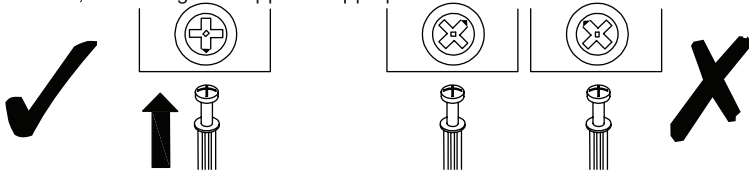

EN_ CAM LOCK: When fitting cam lock, ensure starting position is correct before you insert connecting quickfit.

FR_ SERRURE BATTEUSE: Avant d'insérer la serrure batteuse, veillez à la bonne orientation avant d'insérer le raccord rapide.

ES_ CIERRE DE LA CÁMARA: Cuando instale el cierre de la cámara, asegúrese de que la posición de inicio es correcta antes de que inserte el quickfit conector.

DE_ CAM-LOCK: Achten Sie bei der Montage des Cam-Locks auf die richtige Ausgangsposition, bevor Sie den Quickfit einsetzen.

IT_ BLOCCAGGIO A CAMMA: Quando si monta il bloccaggio a camma, assicurarsi che la posizione iniziale sia corretta prima di inserire il montaggio rapido di collegamento.

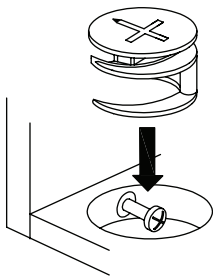

EN_ Quickfit head should be in the centre of the cam lock when the two panels are joined.

Cam lock should be inserted before quickfit.

FR_ Lorsque les deux panneaux sont assemblés, la tête du raccord rapide doit reposer au centre de la serrure batteuse.

Il faut insérer la serrure batteuse avant le raccord rapide.

ES_ El cabezal del quickfit debe estar en el centro del cierre de la cámara cuando se unan los dos paneles.

Se debe insertar el cierre de la cámara antes que el quickfit.

DE_ Der Quickfit-Kopf sollte sich in der Mitte des Cam-Locks befinden, wenn die beiden Platten zusammengefügt sind.

Der Cam-Lock sollte vor dem Quickfit eingesetzt werden.

IT_ La testa del montaggio rapido deve trovarsi al centro del bloccaggio a camma quando i due pannelli sono uniti.

Il Bloccaggio a Camma deve essere inserito prima del montaggio rapido.

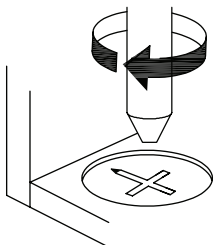

EN_ Turn cam lock clockwise to tighten.

FR_ Faites tourner la serrure batteuse dans le sens des aiguilles d'une montre pour la resserrer.

ES_ Gire el cierre de la cámara en sentido horario para apretarlo.

DE_ Drehen Sie den Cam-Lock im Uhrzeigersinn, um ihn festzuziehen.

IT_ Ruotare il bloccaggio a camma in senso orario per stringere.

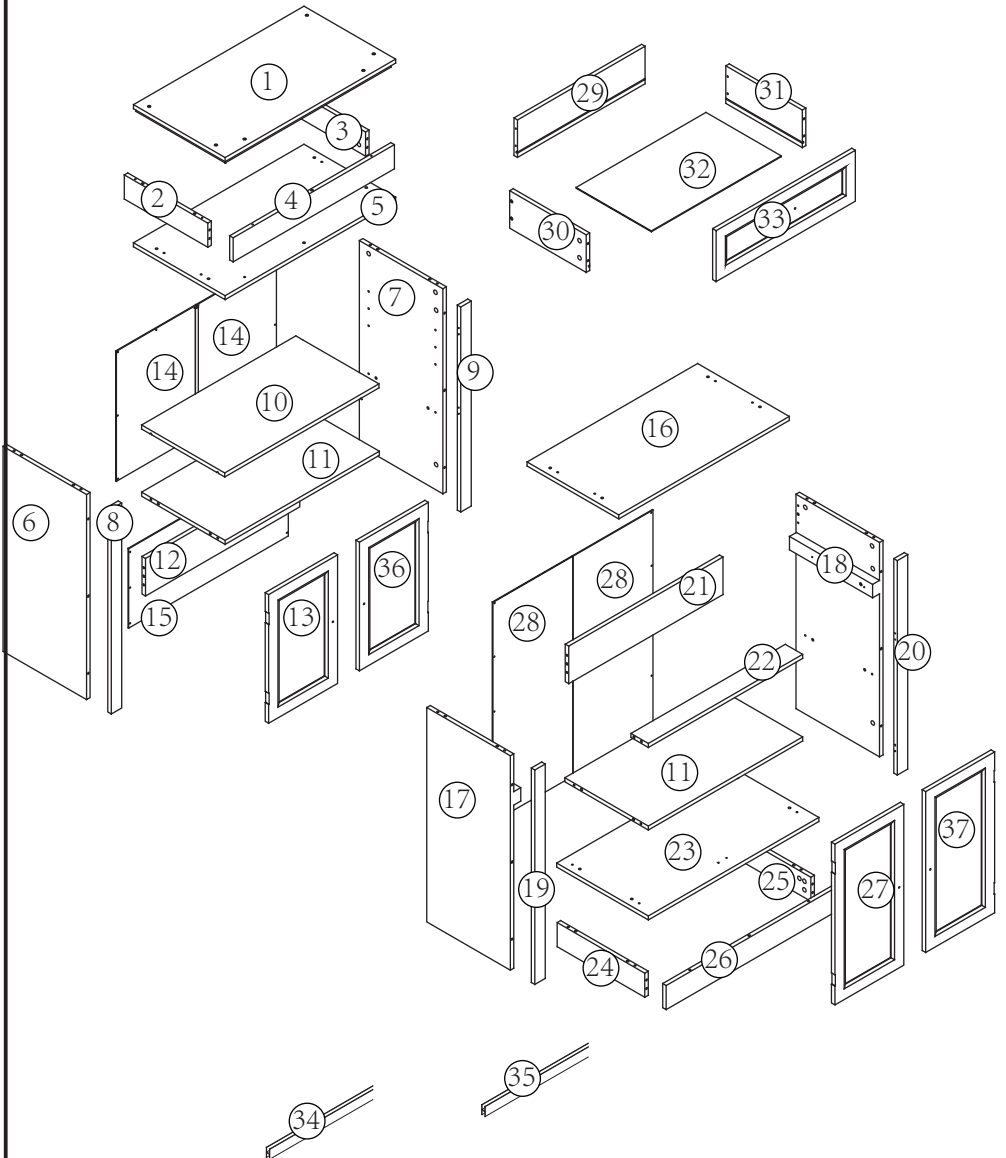

A x33

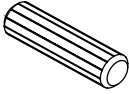

B x24

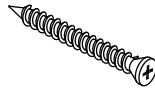

5X40mm

C x52

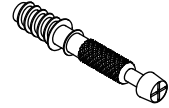

7X39mm

D x52



E x 8



F x 4



G x 8

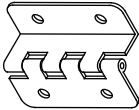

H x42



3.5X14mm

I x 2

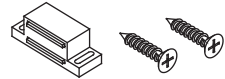

J x38



3X12mm

K x 8



L x52



M x 4

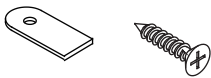

N x 1



O x 5



P x 2

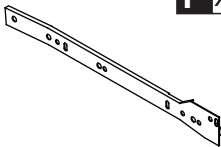

Q x 2

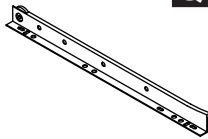

R x 4



S x 2

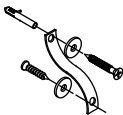

Assembly Instructions

1

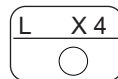
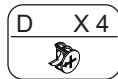
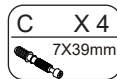
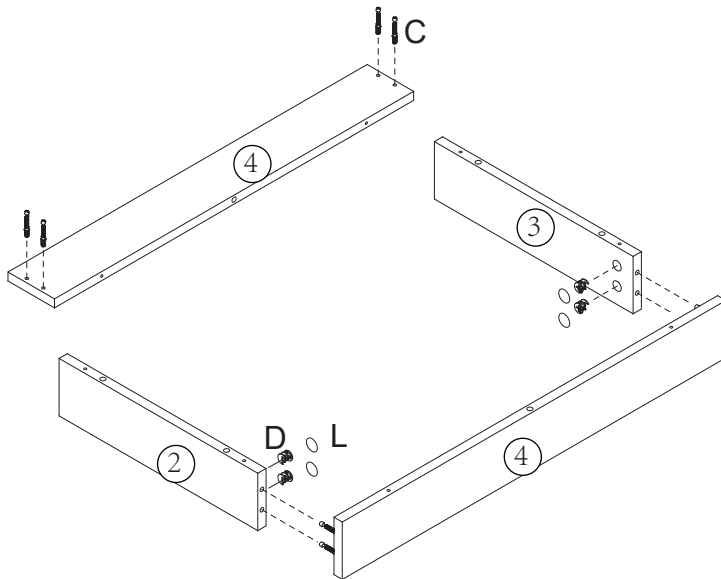

2

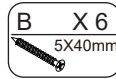
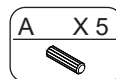
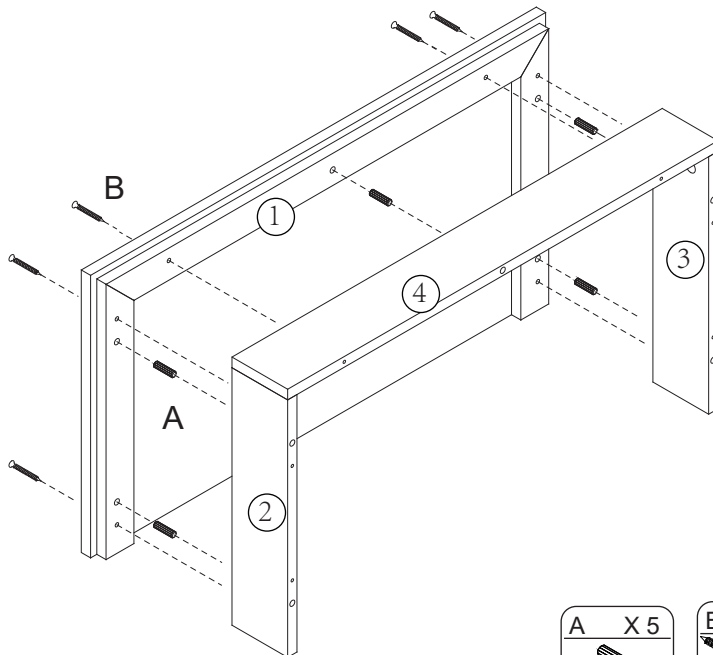

Assembly Instructions

3

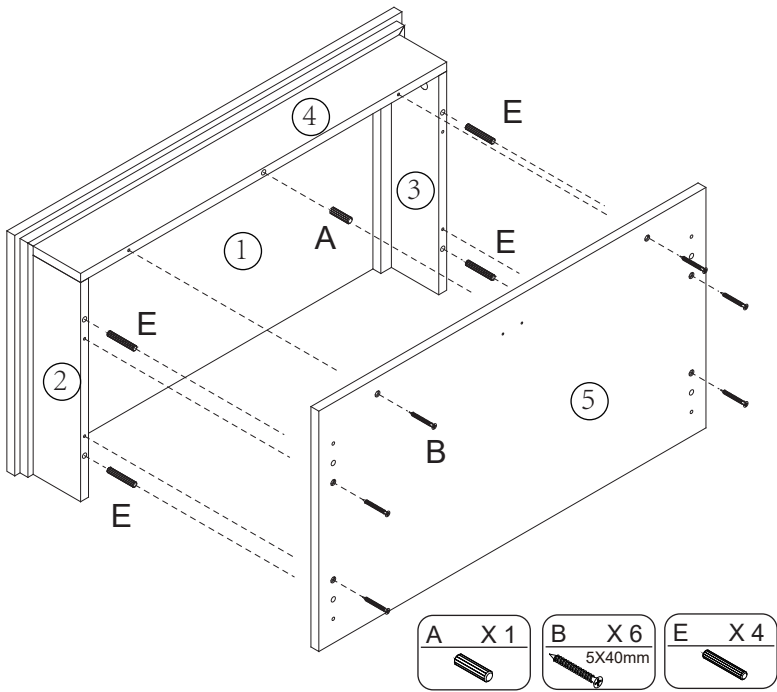

4

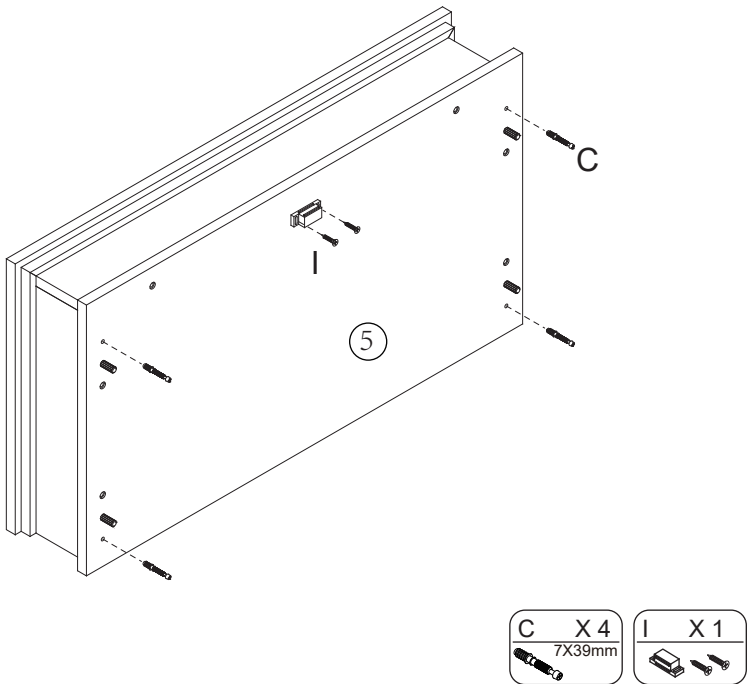

Assembly Instructions

5

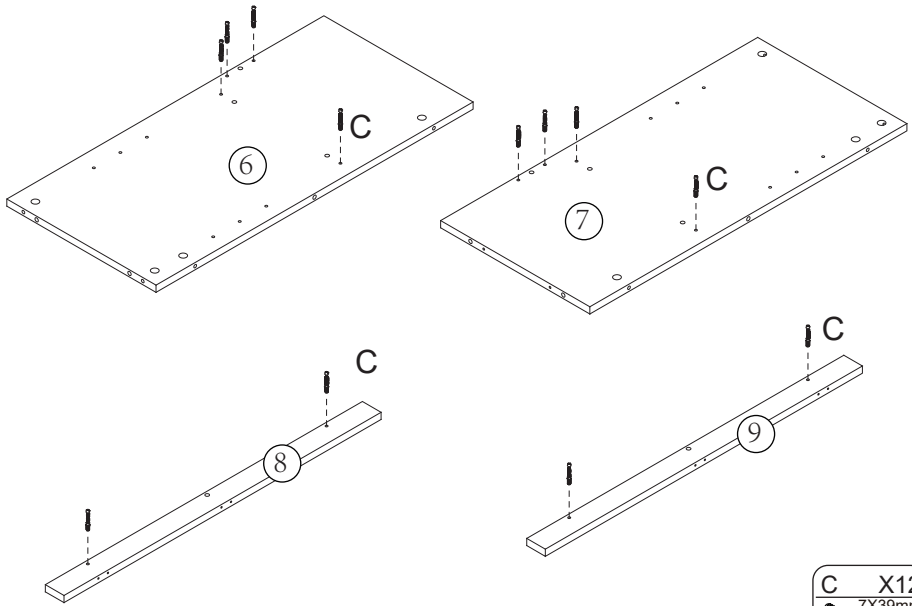

6

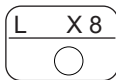
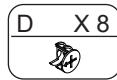
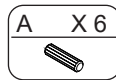
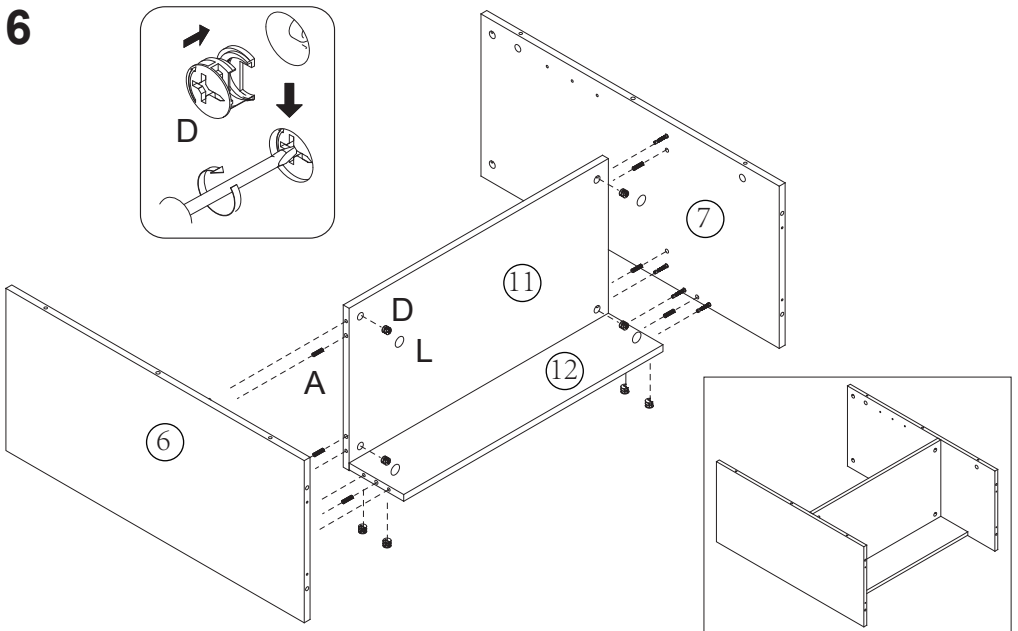

Assembly Instructions

7

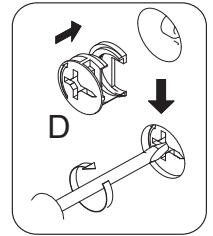
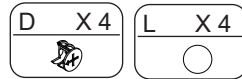
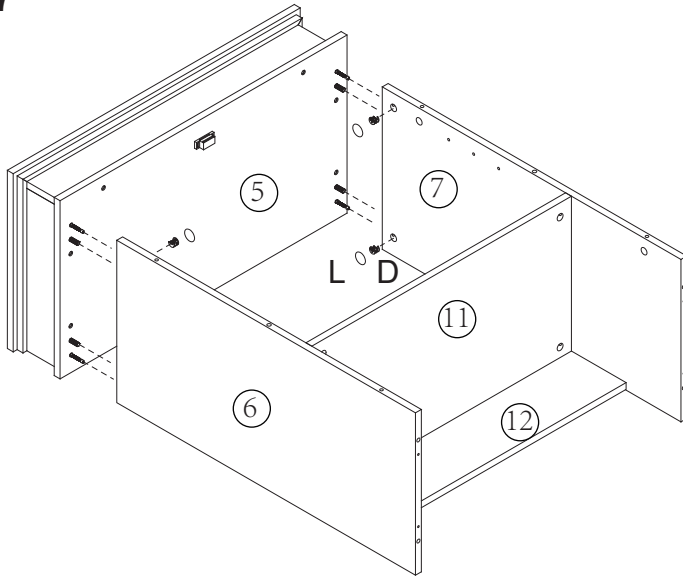

8

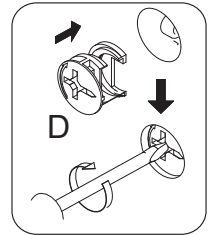
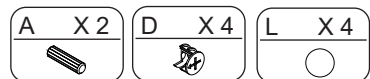
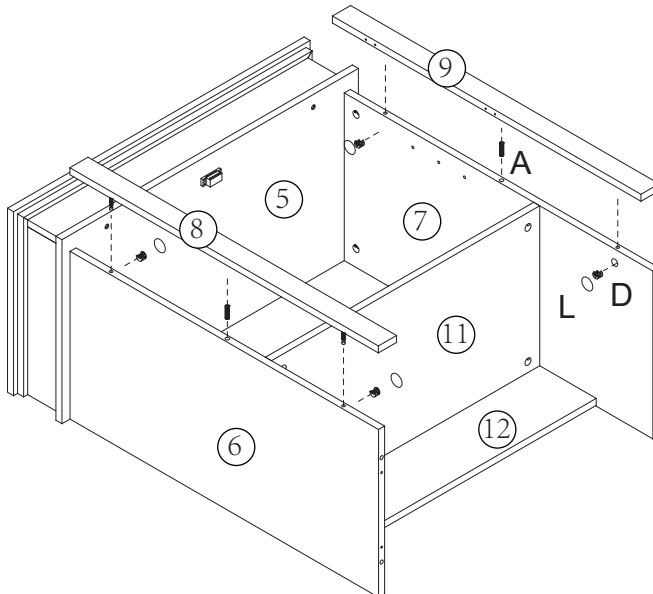

Assembly Instructions

9

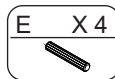
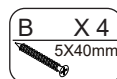
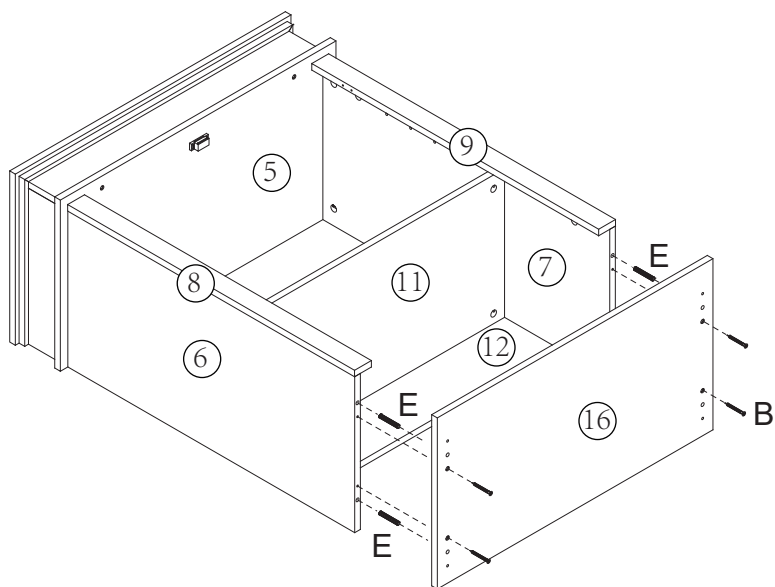

10

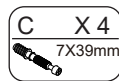
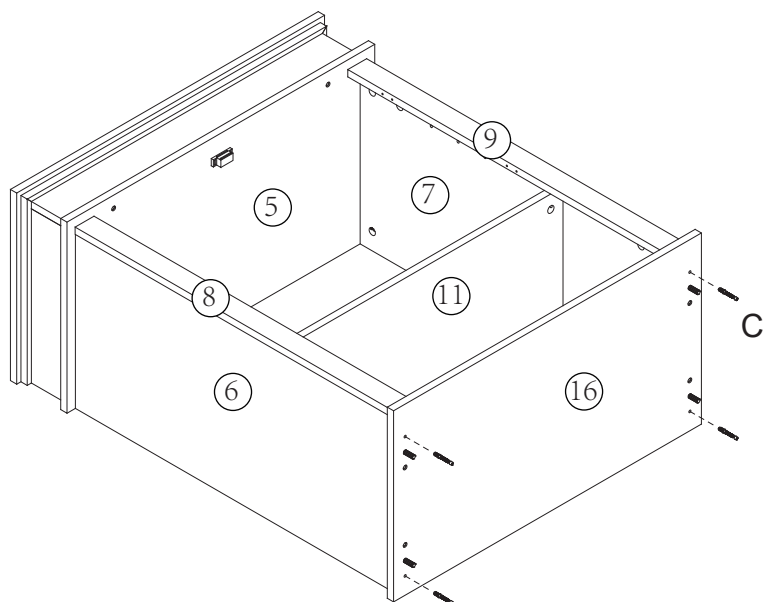

Assembly Instructions

11

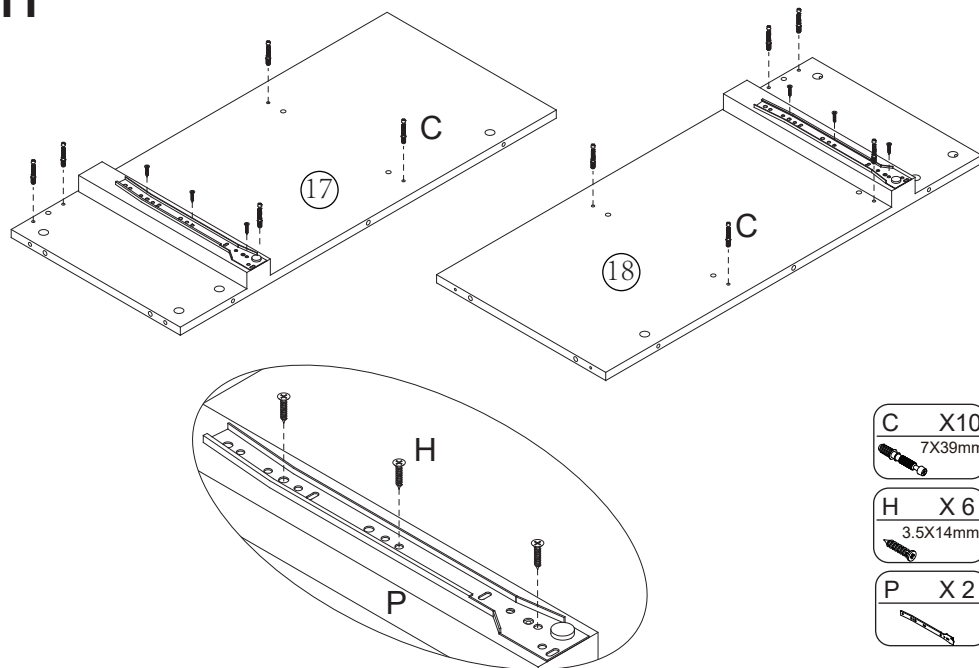

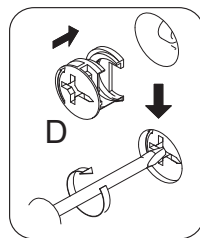
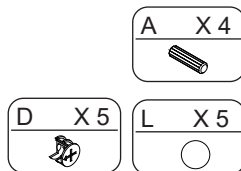
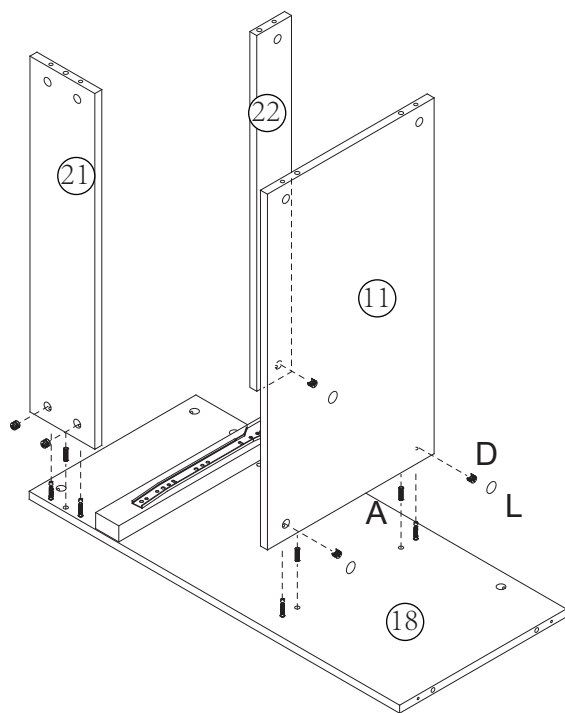

12

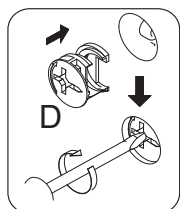
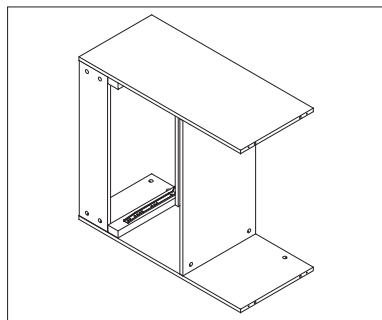
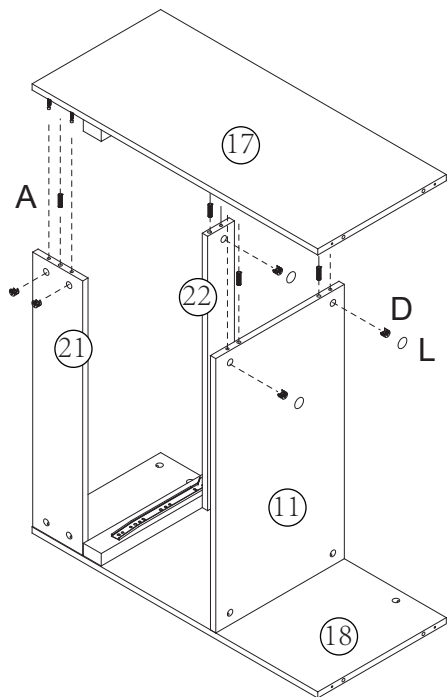

Assembly Instructions

13





A	X 4
	

D	X 5
	

L	X 5
	

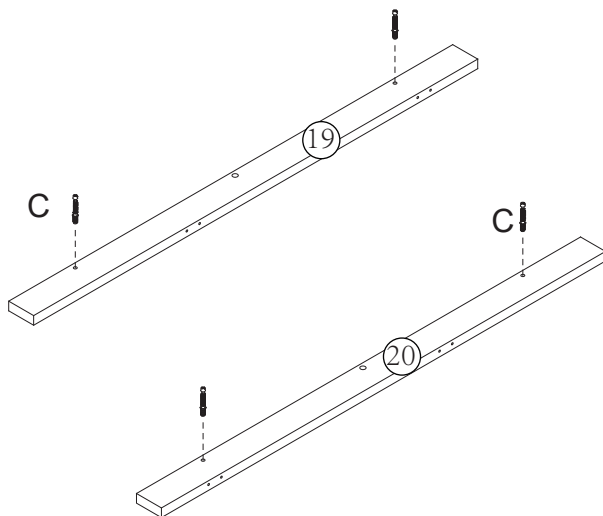
14



C	X 4
7X39mm	
	

Assembly Instructions

15

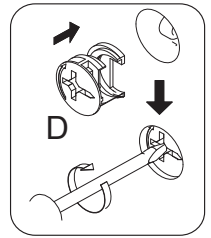
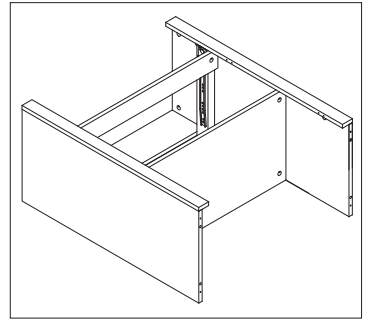
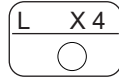
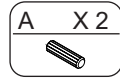
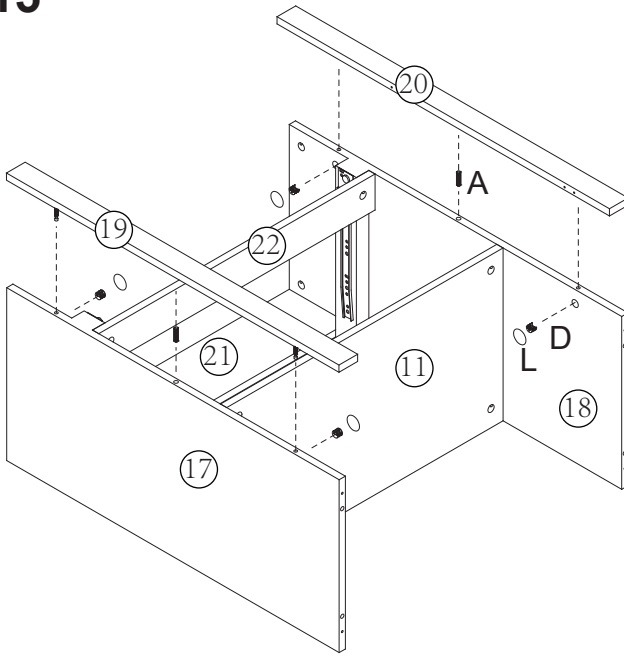

16

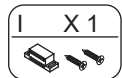
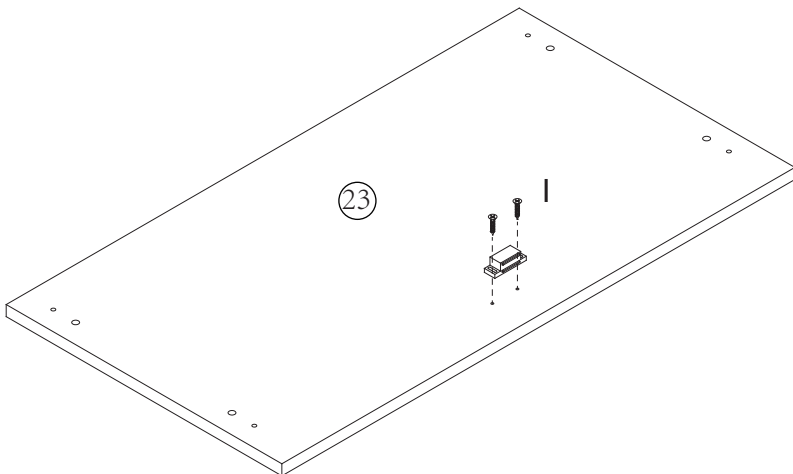

Assembly Instructions

17

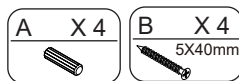
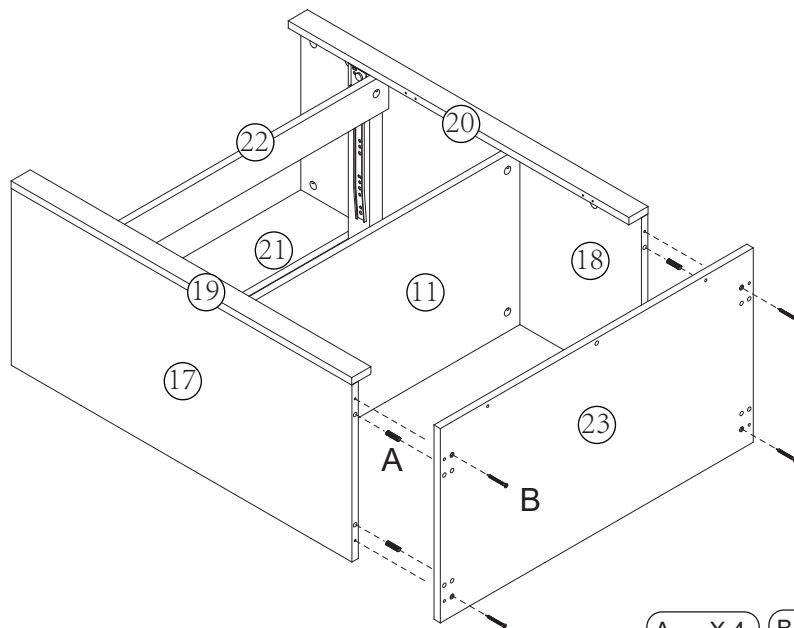

18

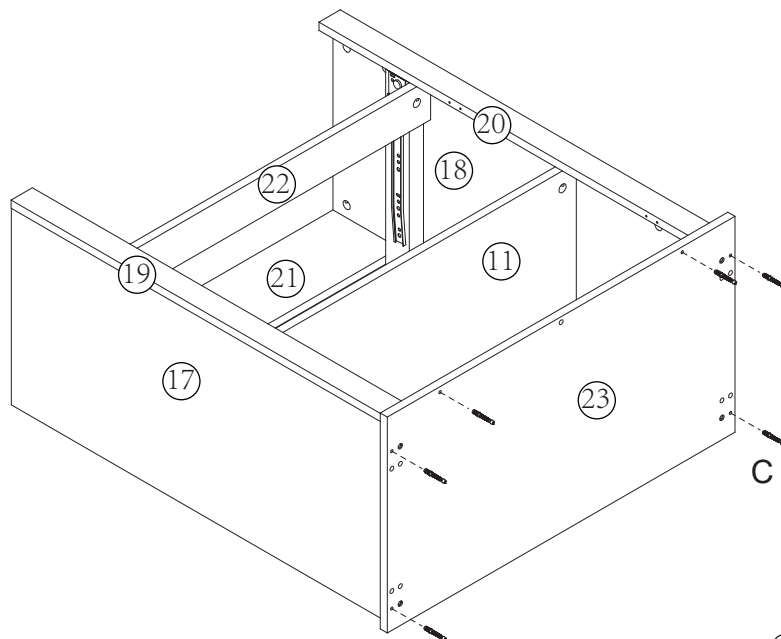

19

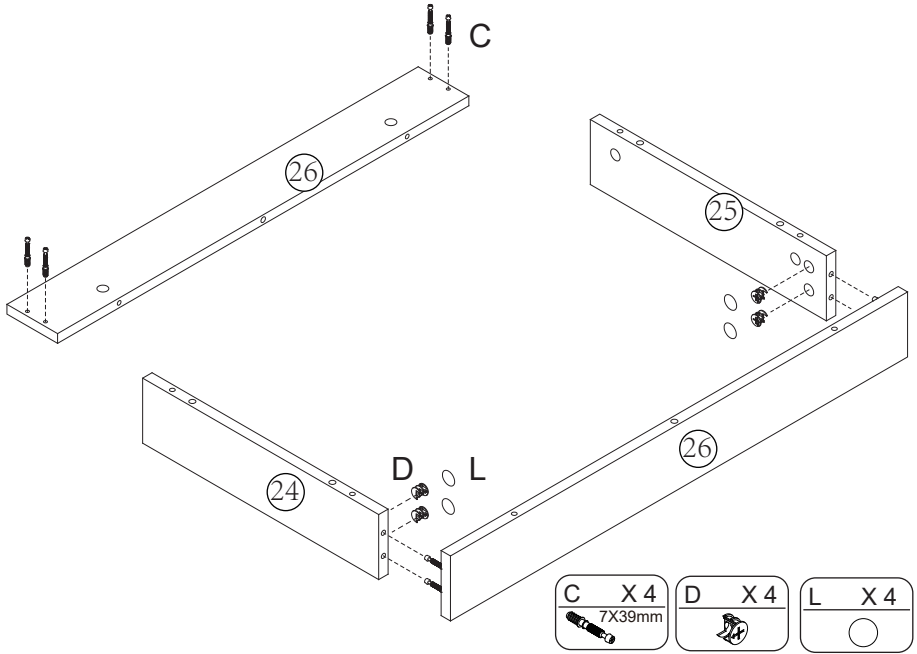

20

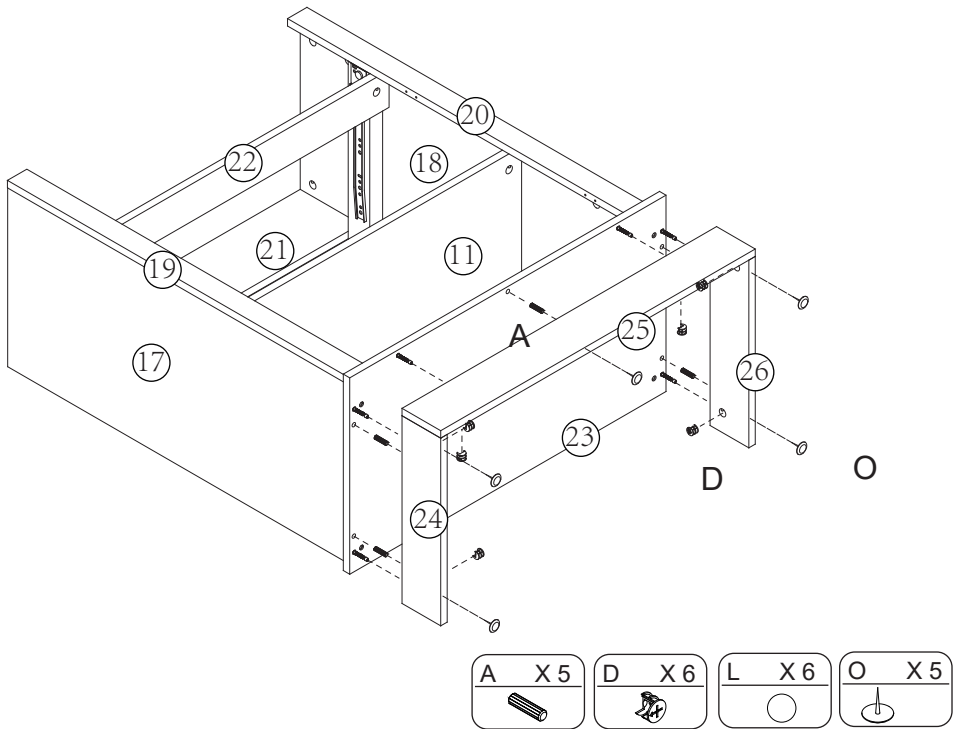

21

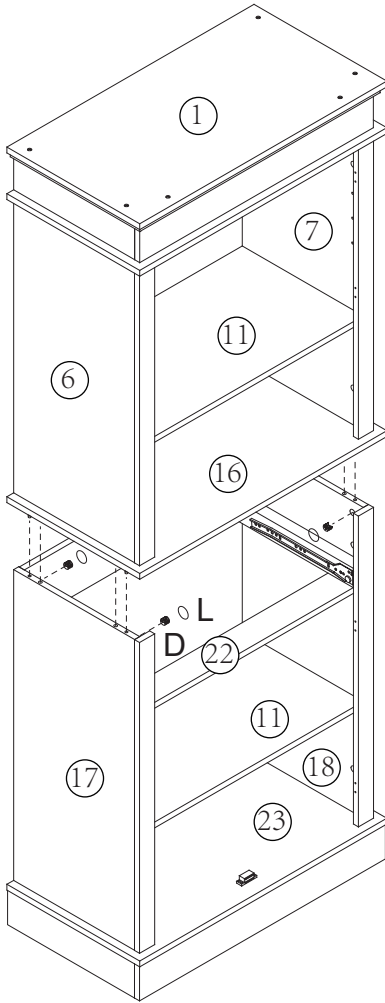

22

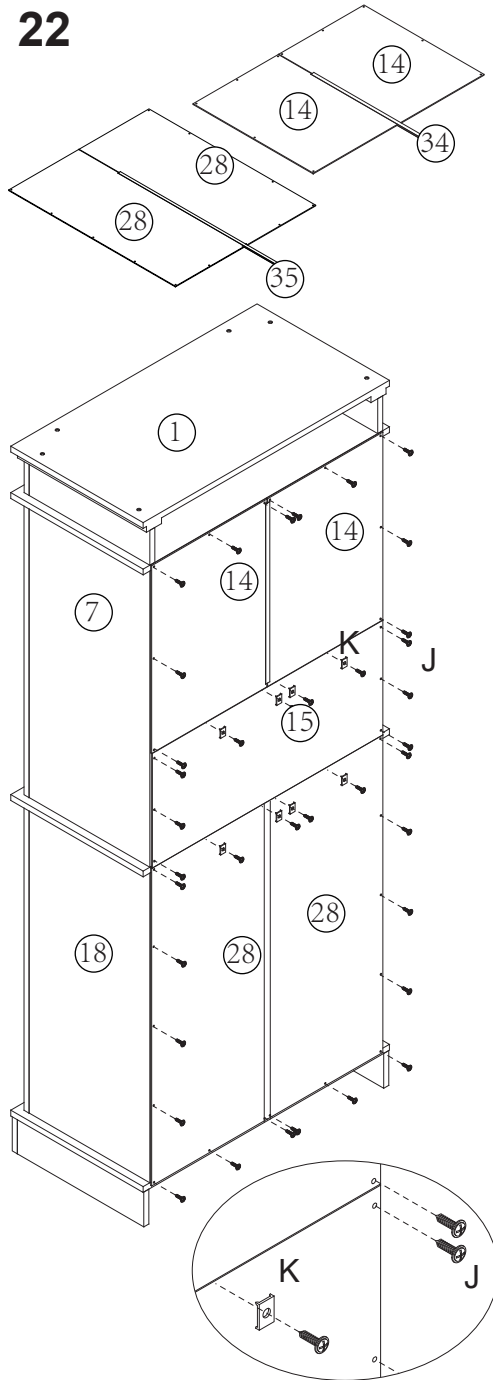

23

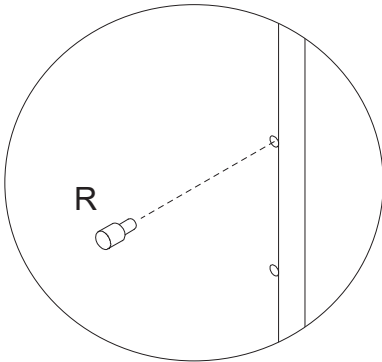
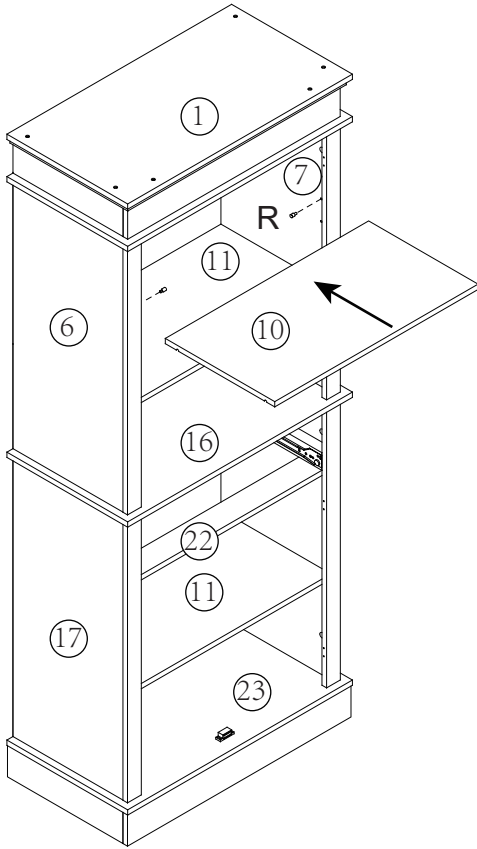

R X4



24

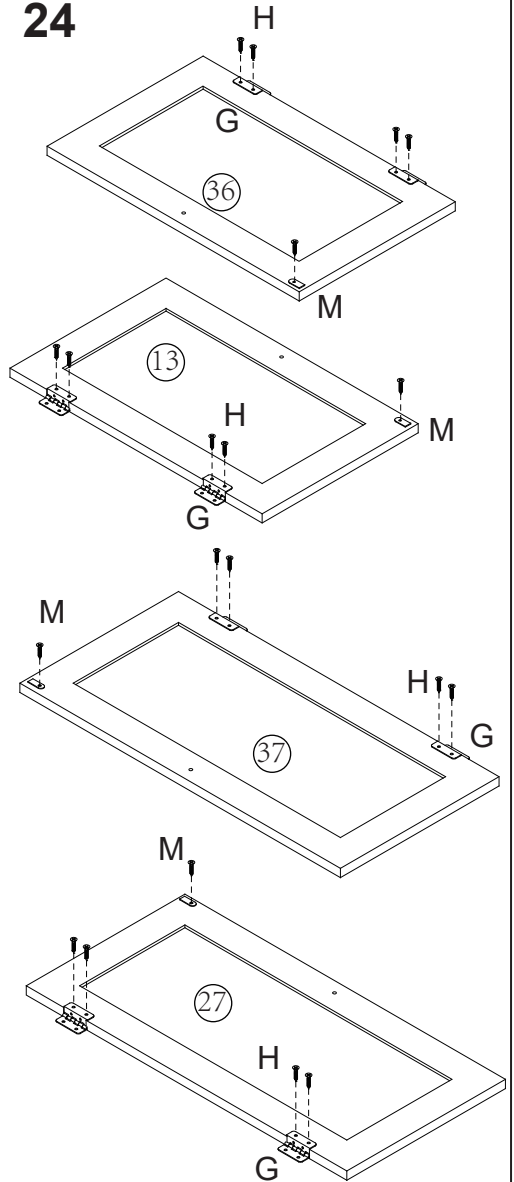

G X8



H X16
3.5X14mm



M X4



Assembly Instructions

25

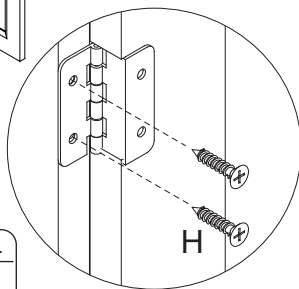
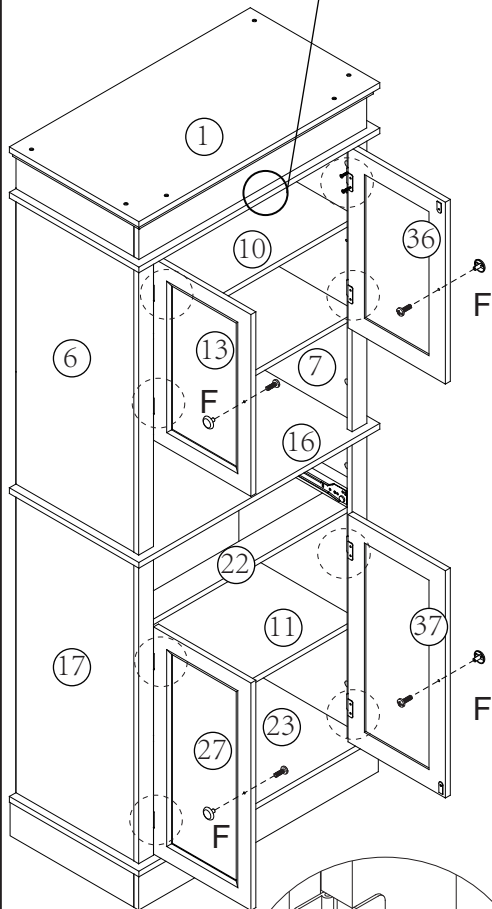
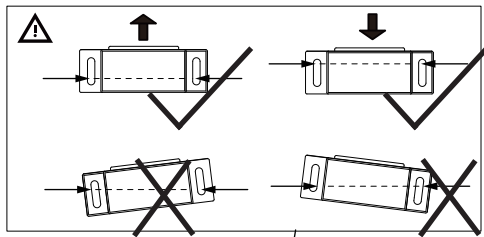

H X16
3.5X14mm

F X4

26

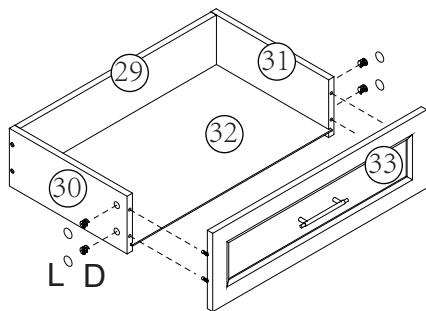
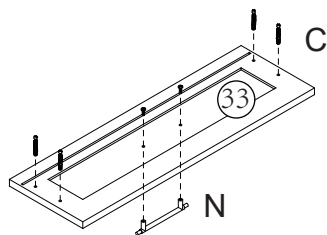
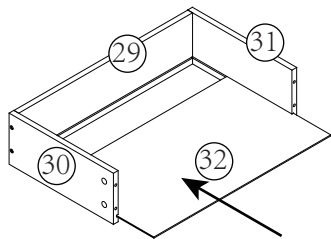
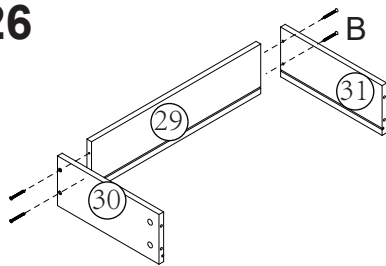

B X4
5X40mm

C X4
7X39mm

D X4

L X4

N X1

Assembly Instructions

27

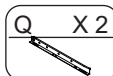
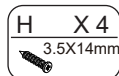
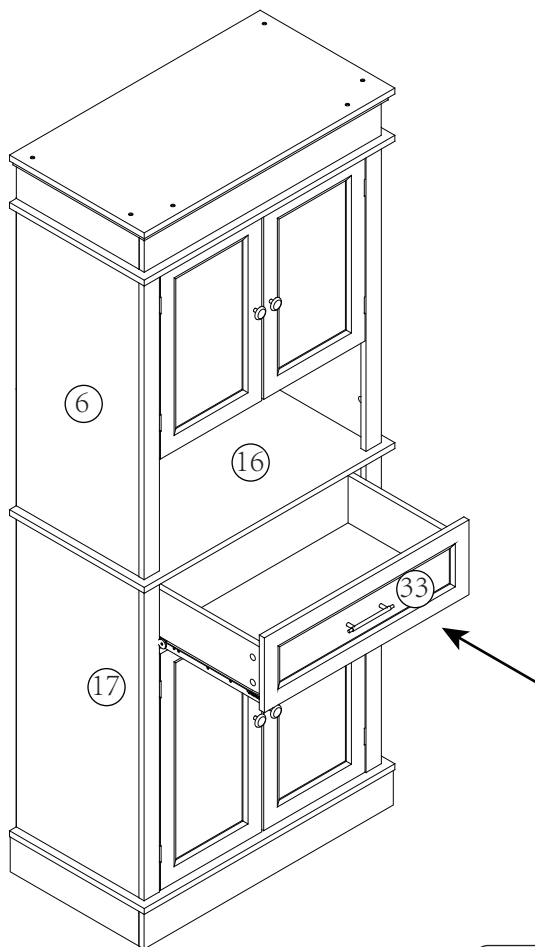
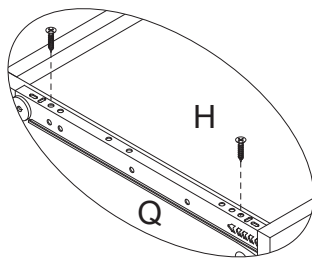
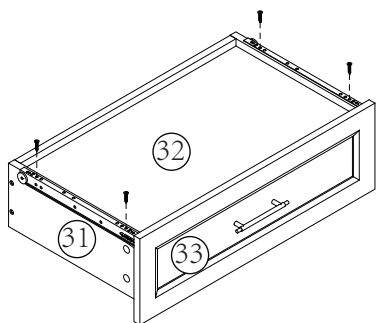

Assembly Instructions

28

