

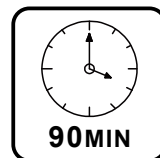

INcaj001_UK_FR_ES_DE_IT

831-572V00_831-572V70

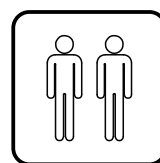
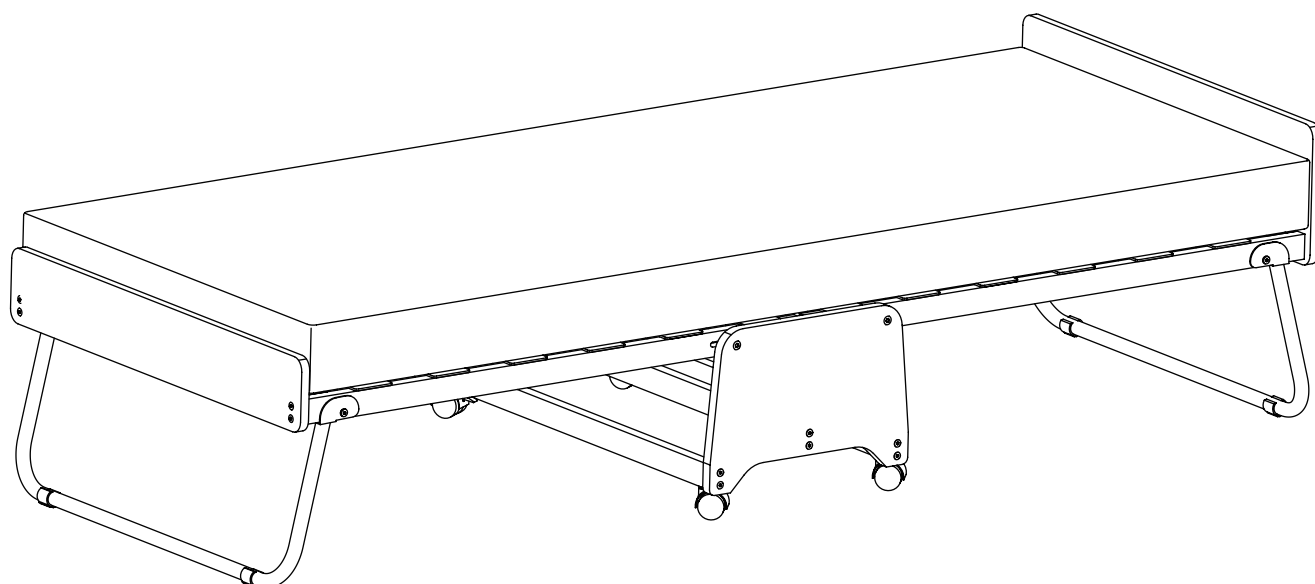

EN_ IMPORTANT, RETAIN FOR FUTURE REFERENCE: READ CAREFULLY.

FR_ IMPORTANT: A LIRE ATTENTIVEMENT ET À CONSERVER POUR CONSULTATION ULTÉRIEURE.

ES_ IMPORTANTE, LEA Y GUARDE PARA FUTURAS REFERENCIAS.

DE_ „WICHTIG! SORGFÄLTIG LESEN UND FÜR SPÄTER NACHSCHLAGEN AUFBEWAHREN.“

IT_ IMPORTANTE! CONSERVARE IL PRESENTE MANUALE PER FUTURO RIFERIMENTO E LEGGERLO ATTENTAMENTE.

PARTS

A x02



B x01



C x02

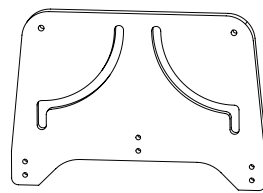

D x02

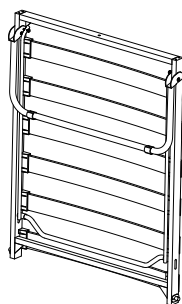

E x01

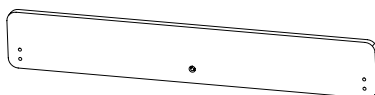

F x01

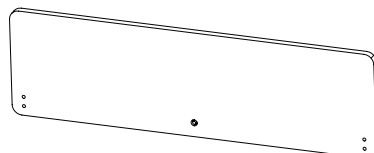

G x01

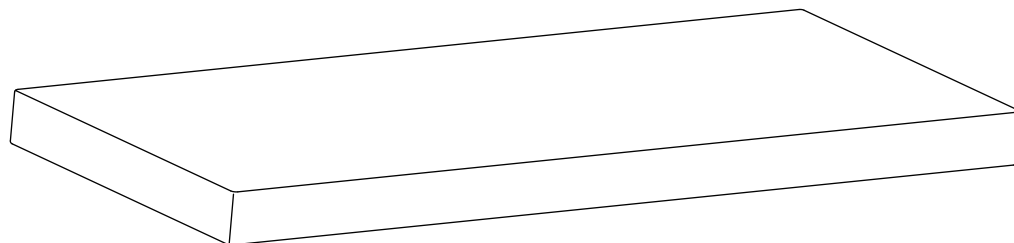

HARDWARE

1 x02
Wheels

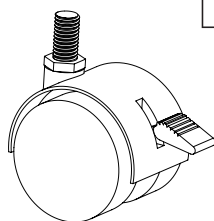

2 x02
Wheels

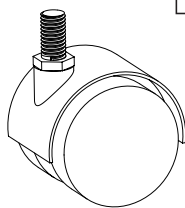

3 x12
M6x35
+1 (spare)

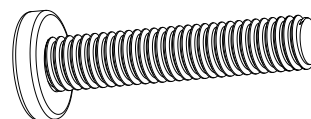

4 x10
M6x30
+1 (spare)

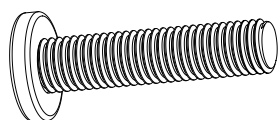

5 x04
Pad
+1 (spare)

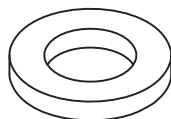

6 x01
4mm

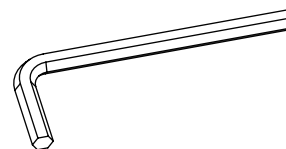

7 x01
12-14

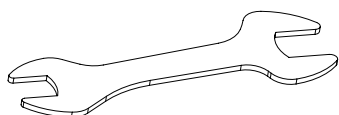



Note : Do not tighten bolts fully until all parts are connected!

Note : Ne serrez pas les boulons à fond tant que toutes les pièces ne sont pas connectées!

Hinweis: Ziehen Sie die Schrauben erst fest an, wenn alle Teile verbunden sind!

Nota: non serrare completamente i bulloni fino a tutte le parti non sono ancora collegate!

Nota: No apriete los tornillos completamente hasta que todas las partes están conectadas!

01

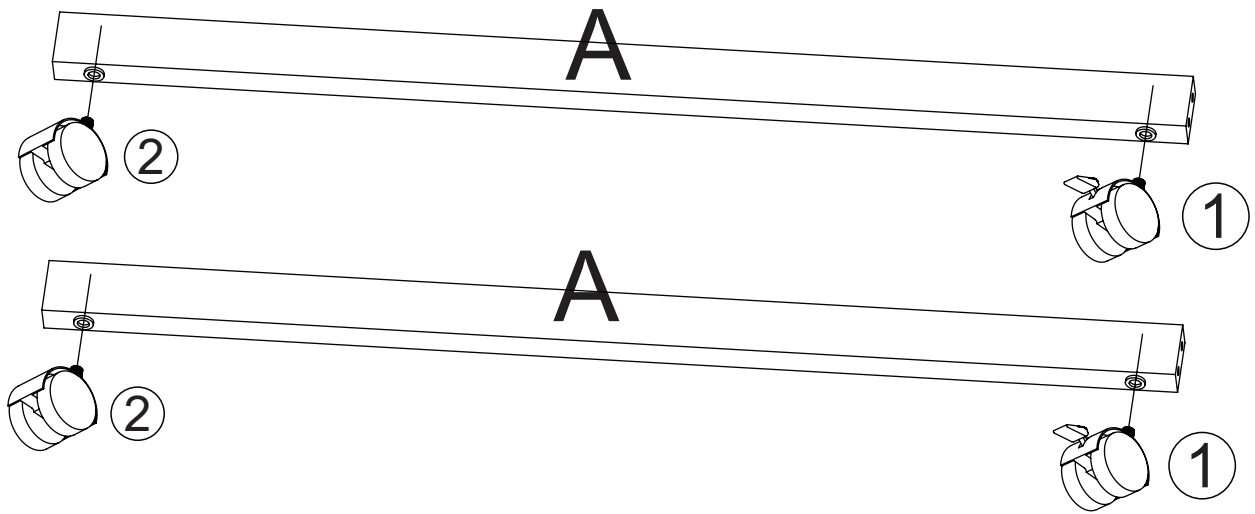
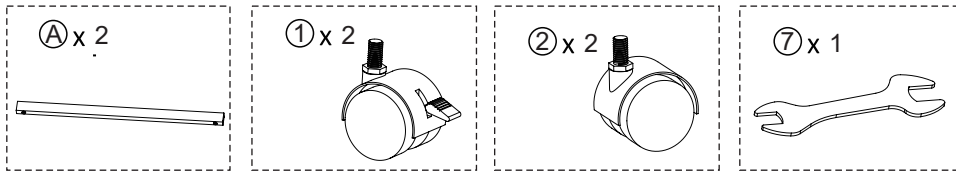

02

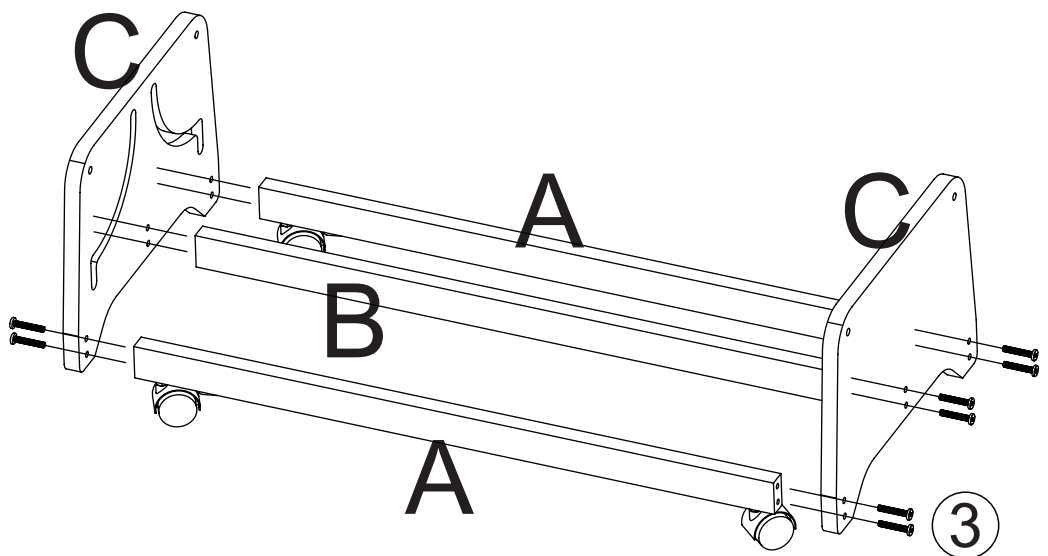
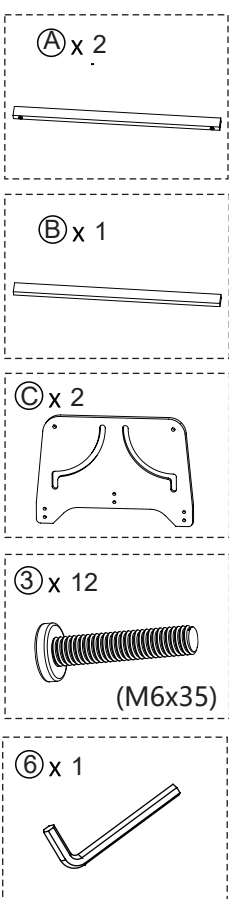

① x 2



⑥ x 1

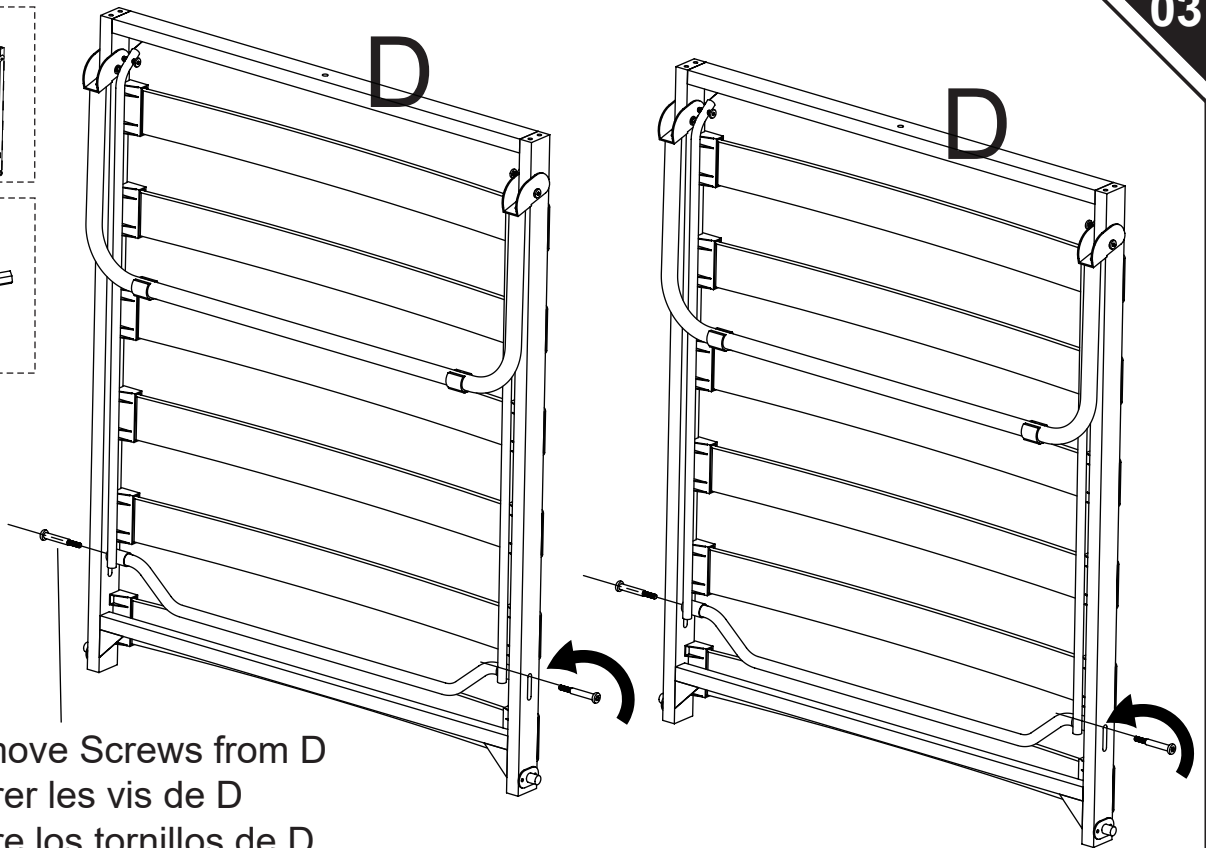

EN: Remove Screws from D

FR: Retirer les vis de D

ES: Retire los tornillos de D

DE: Schrauben von D entfernen

IT: Rimuovere le viti da D

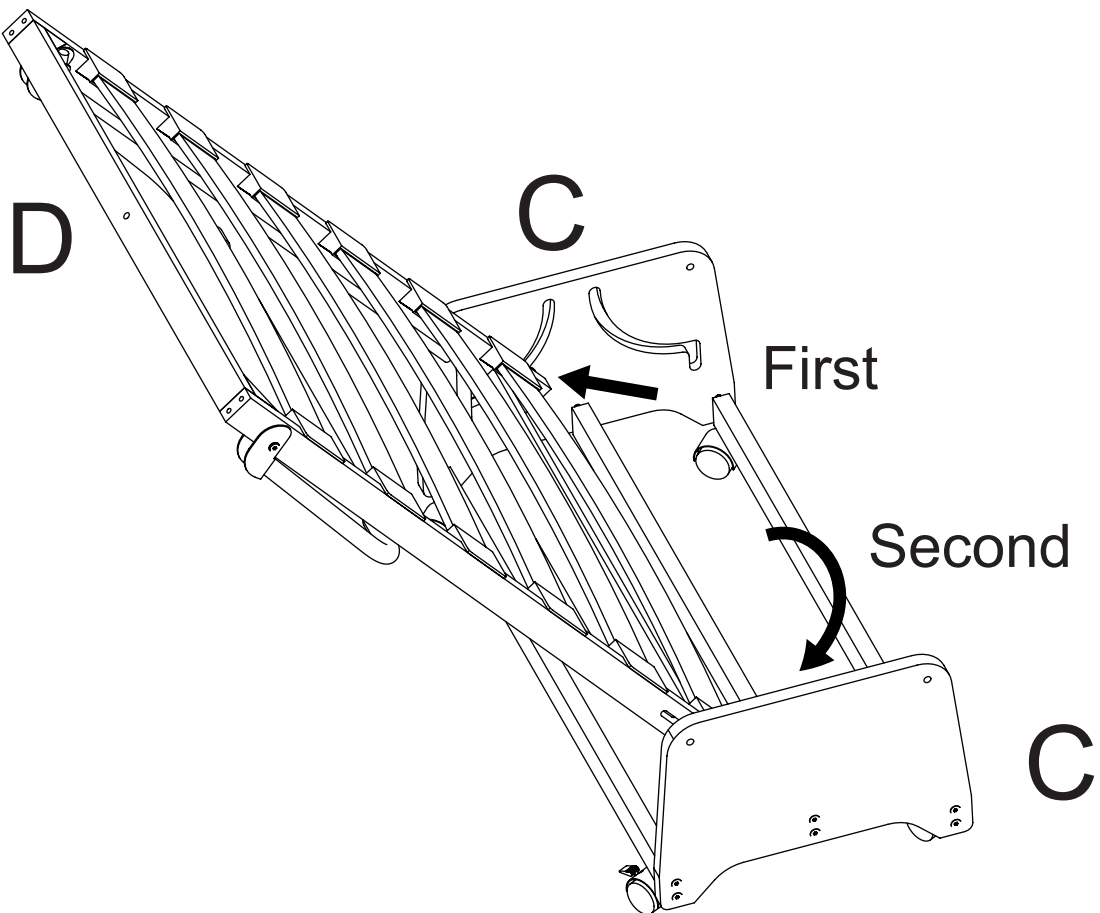

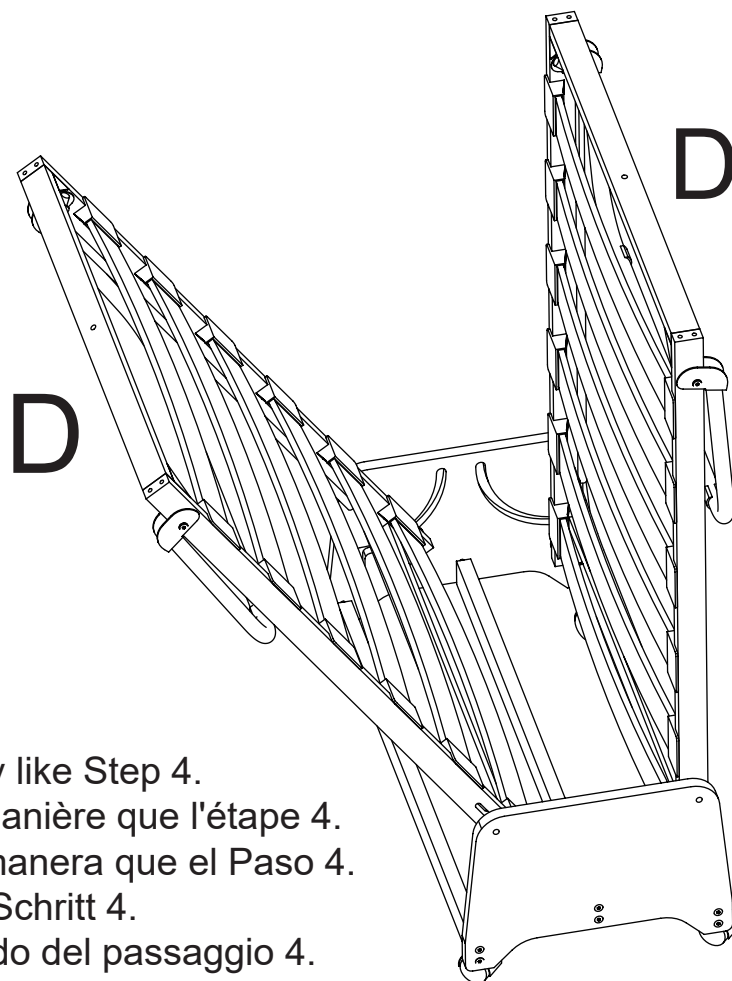

EN: The same way like Step 4.

FR: De la même manière que l'étape 4.

ES: De la misma manera que el Paso 4.

DE: Genauso wie Schritt 4.

IT: Allo stesso modo del passaggio 4.

Screws removed
from D x 4



⑤ x 4



⑥ x 1

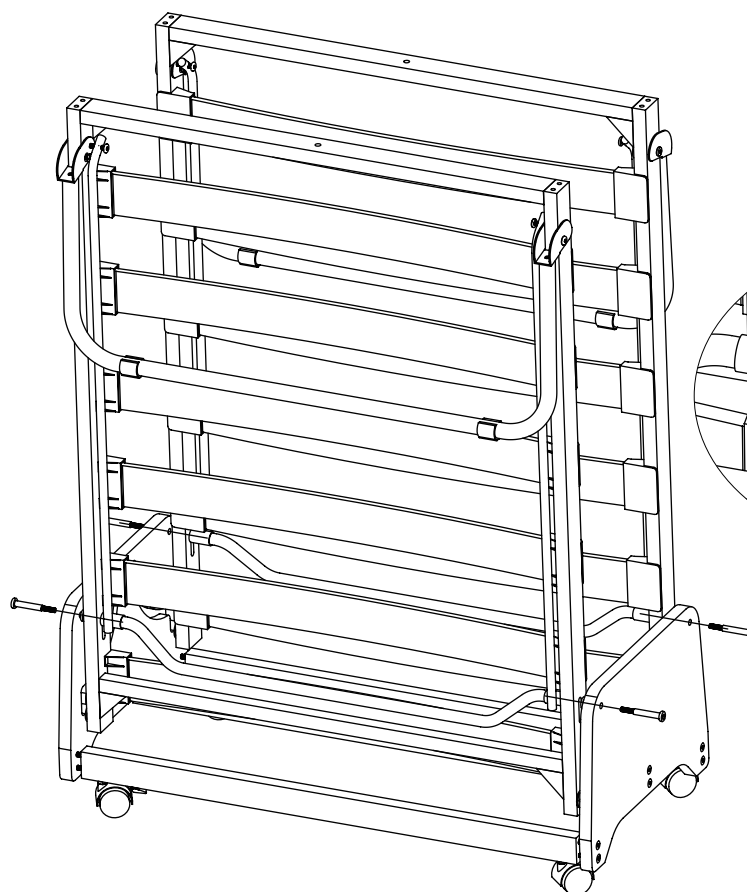

EN: Screws removed from D
FR: vis retirées de D
ES: tornillos retirados de D
DE: Schrauben von D entfernt
IT: viti rimosse da D

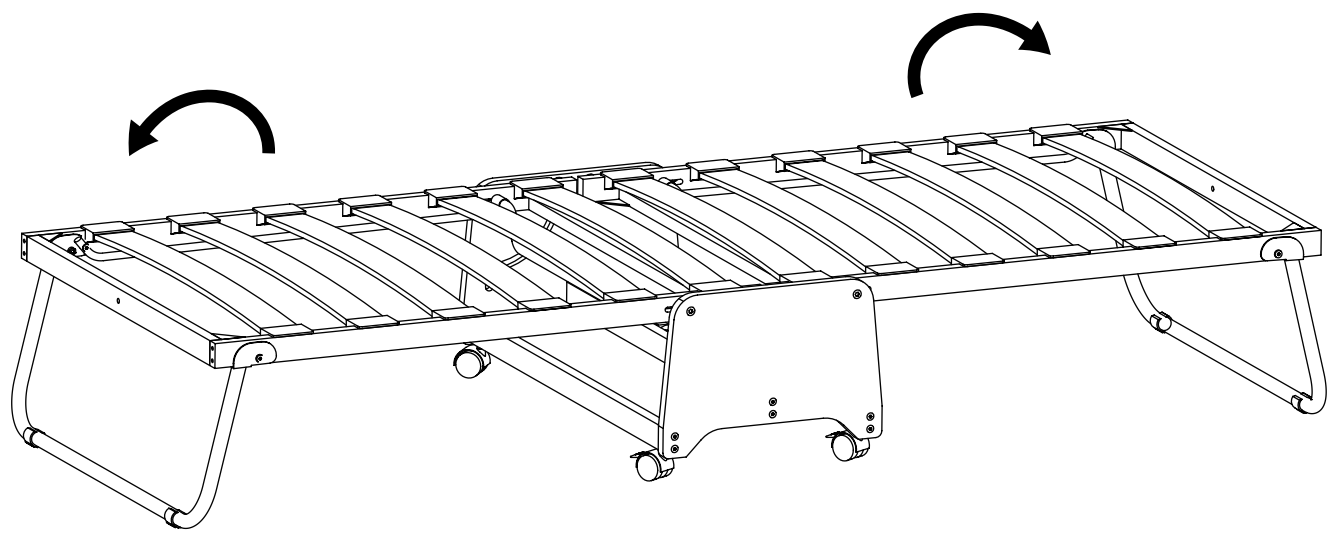
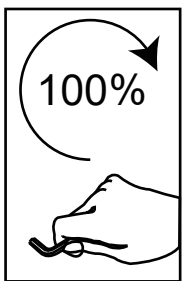
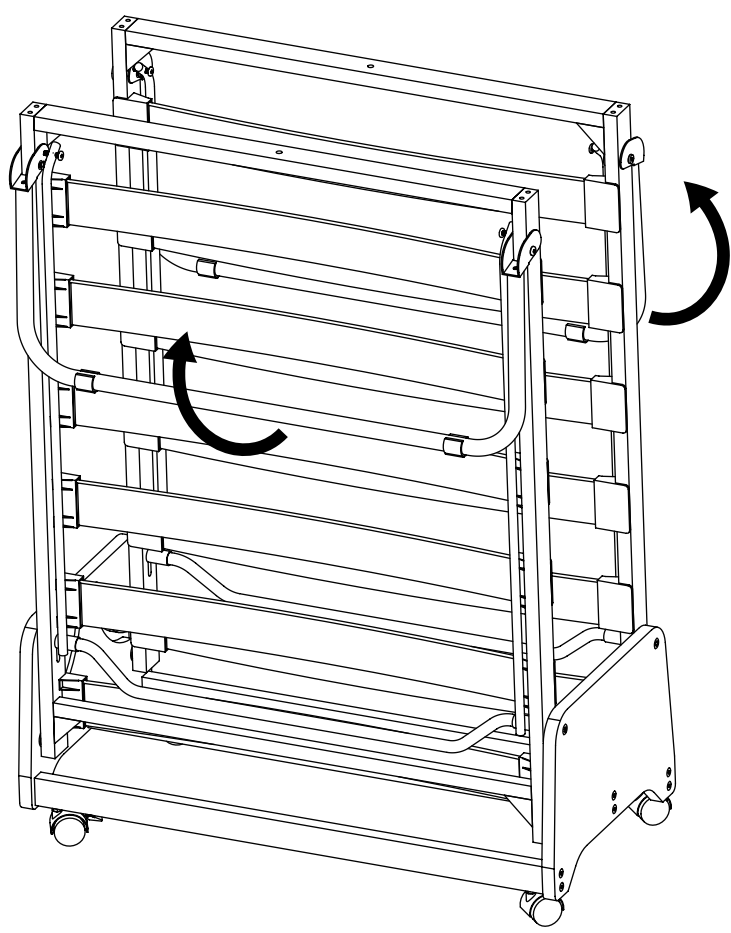
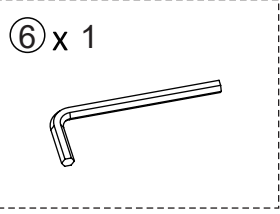

Ⓔ x 1

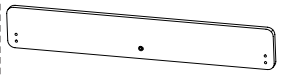

④ x 4

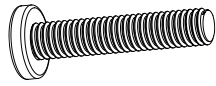

(M6x30)

⑥ x 1

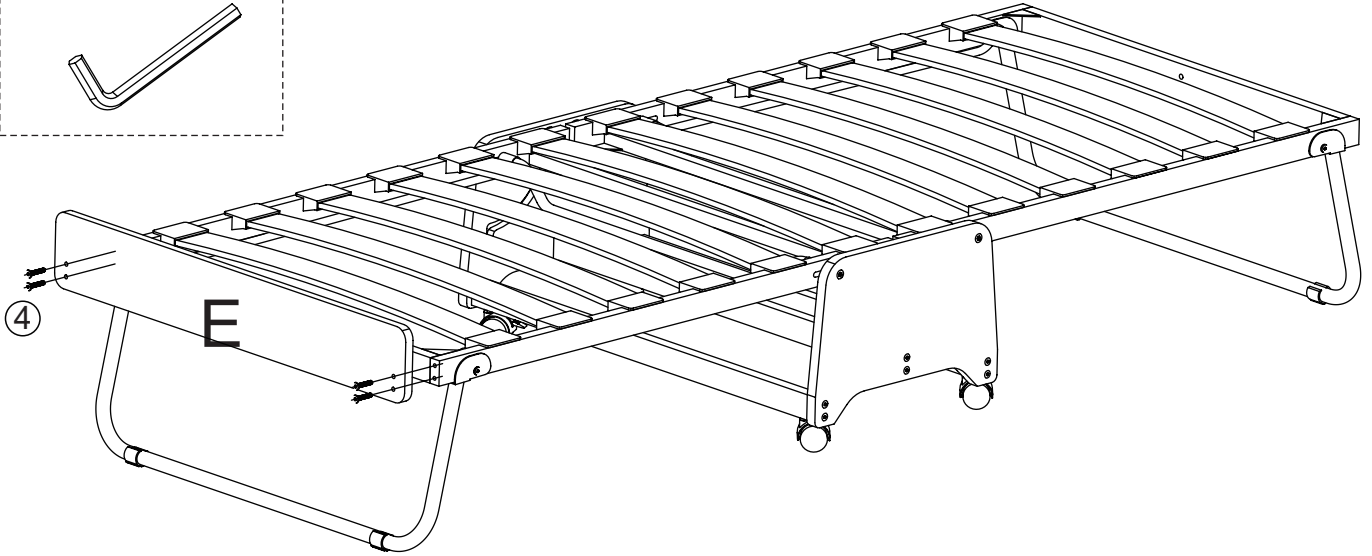
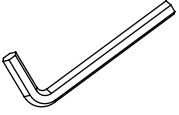

④ x 1

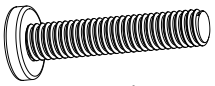

(M6x30)

Ⓒ x 1

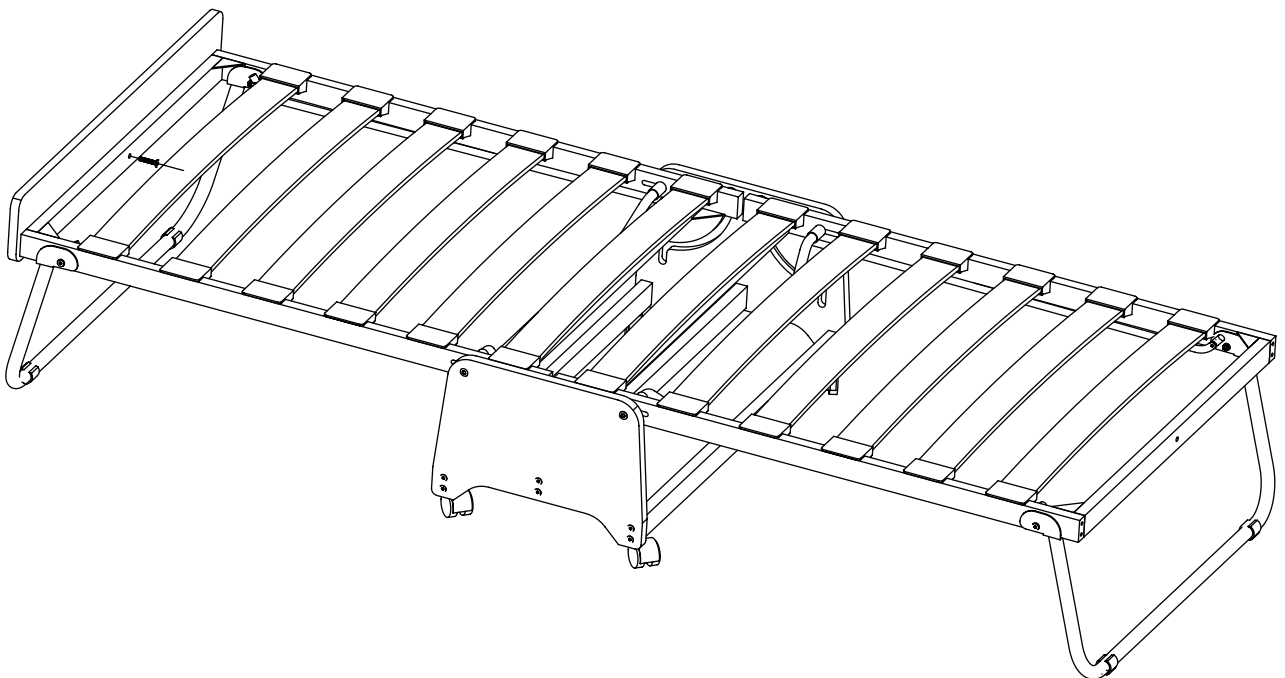
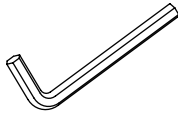

F x 1

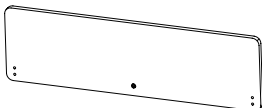

4 x 5

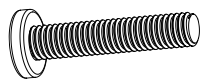

(M6x30)

6 x 1

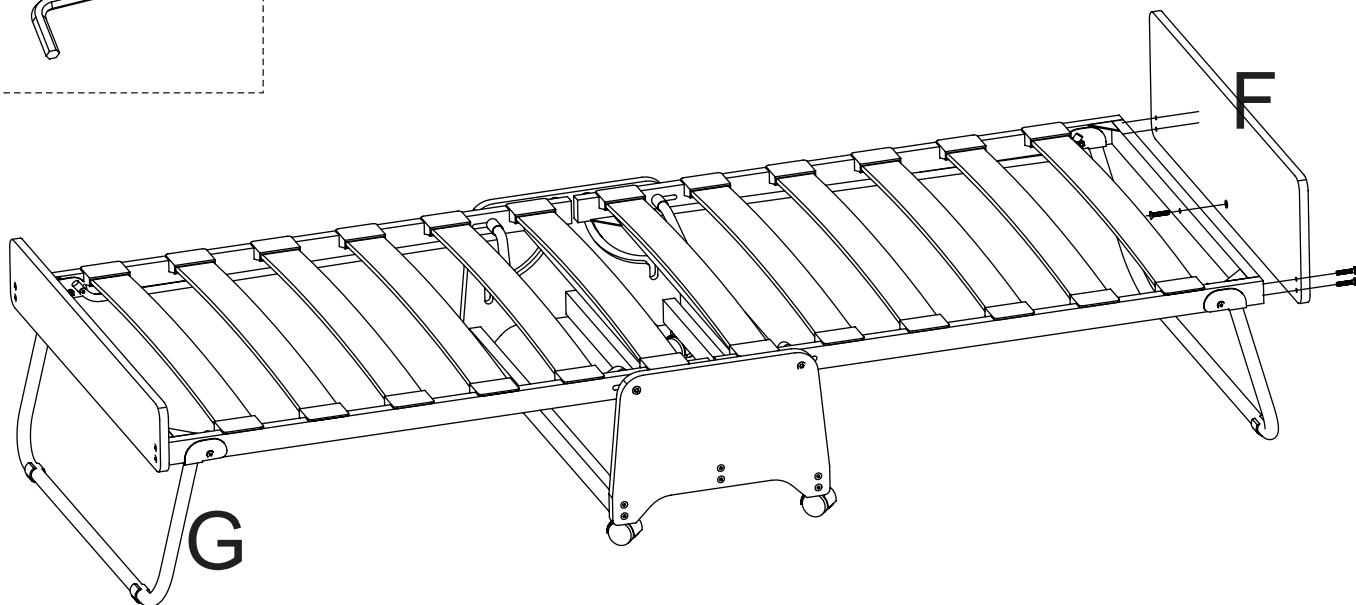
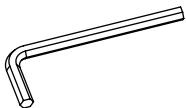

G x 1

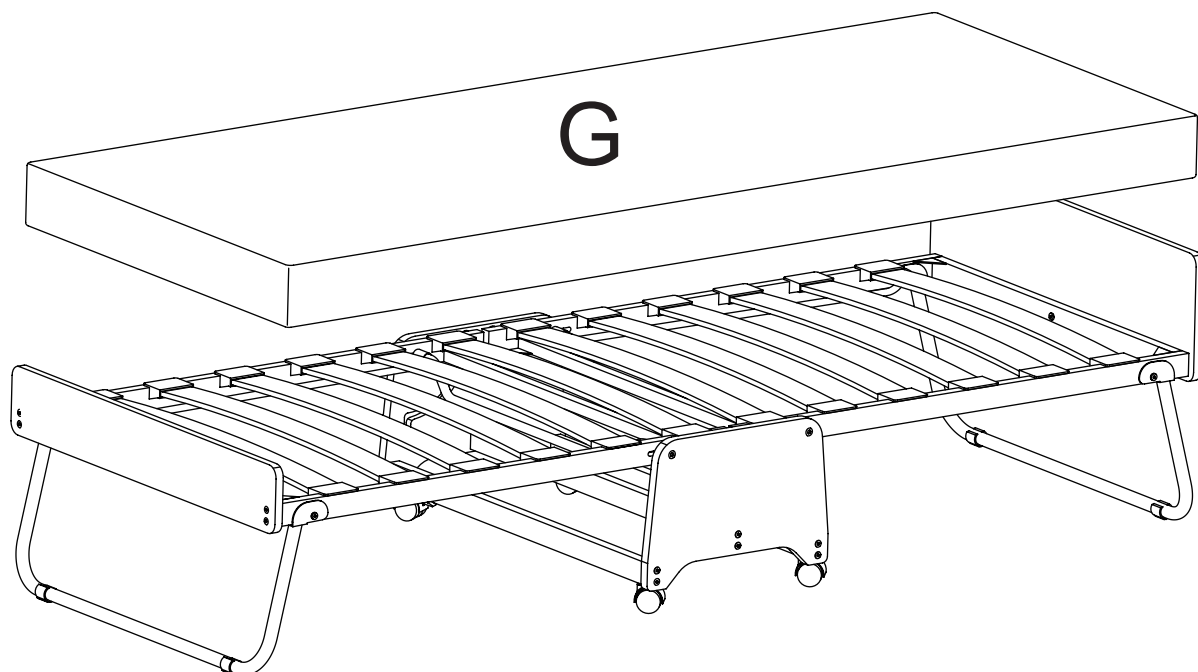
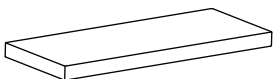

DONE

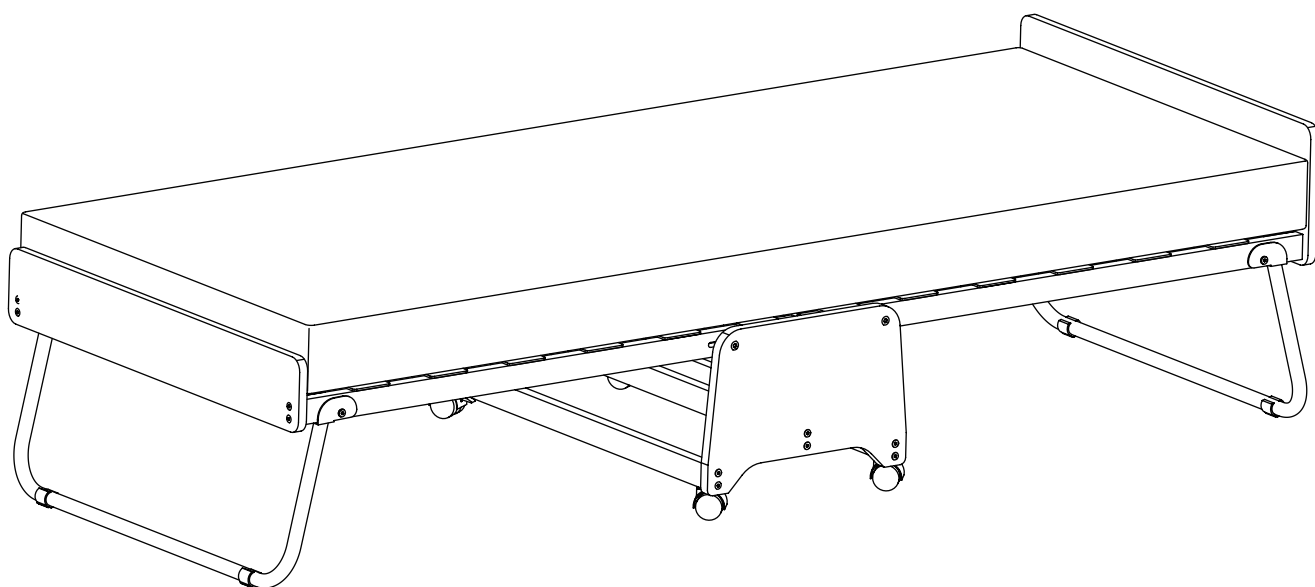

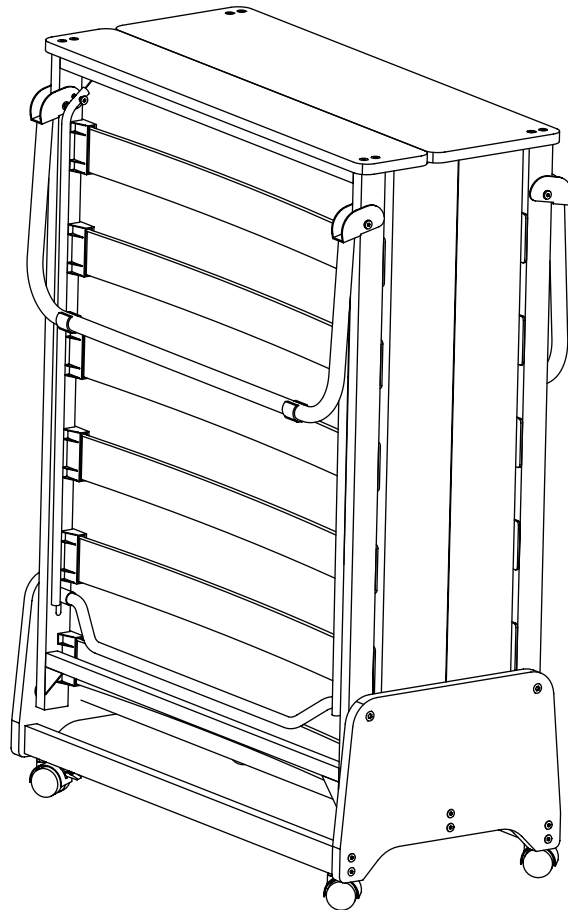
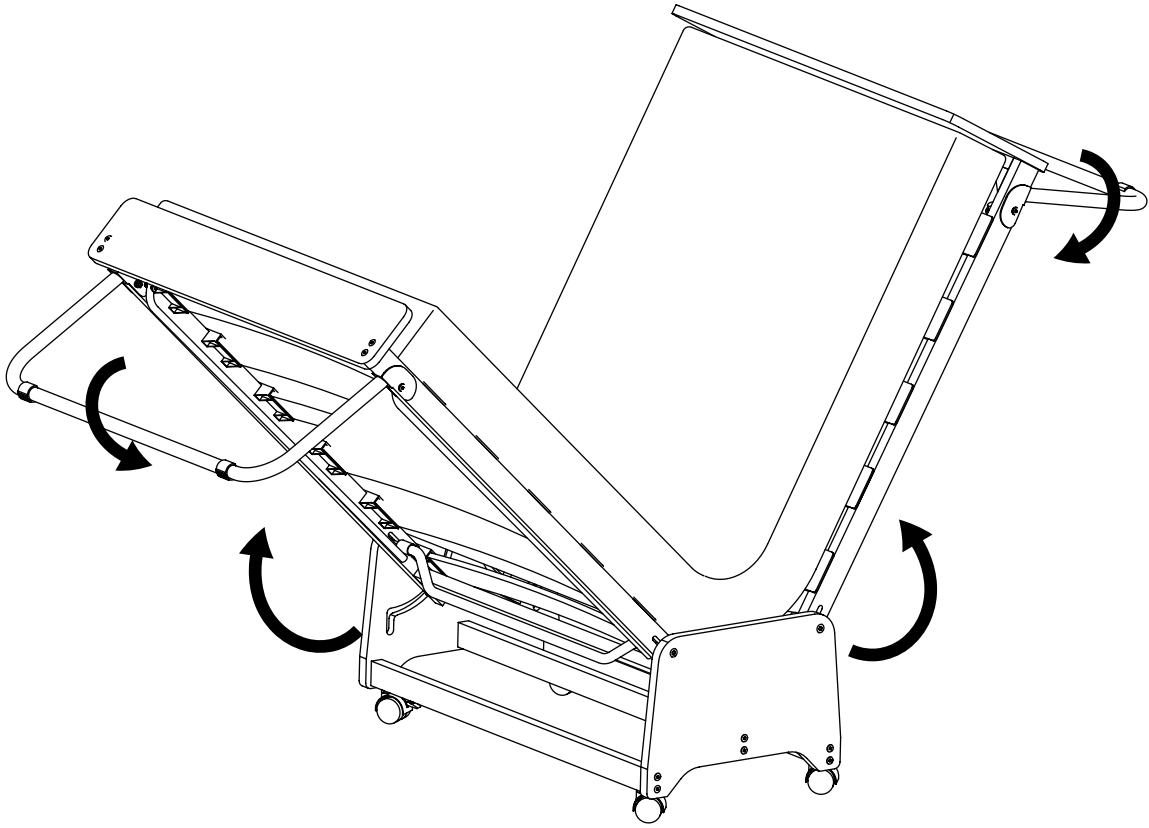



FR

**Pensez à
donner ou recycler.**



ou



ou



Association

Magasin

Déchèterie

<https://quefairedemesdechets.fr>