











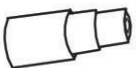

INcbb031\_US\_CA

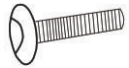
**921-342V80\_921-342V90**

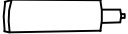
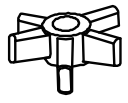
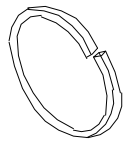

READ AND SAVE THIS INSTRUCTIONS FOR FUTURE USE

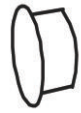
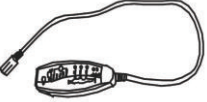
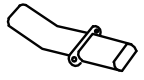
**ASSEMBLY & INSTRUCTION MANUAL**

 <b>A x 1</b>	 <b>E x 1</b>	 <b>I x 2</b>	 <b>M x 4</b>
 <b>B x 1</b>	 <b>F x 1</b>	 <b>J x 1</b>	 <b>N x 4</b>
 <b>C x 1</b>	 <b>G x 5</b>	 <b>K x 5</b>	 <b>O x 4</b>
 <b>D x 1</b>	 <b>H x 1</b>	 <b>L x 12</b>	 <b>P x 1</b>

M8\*40;

M6\*12;

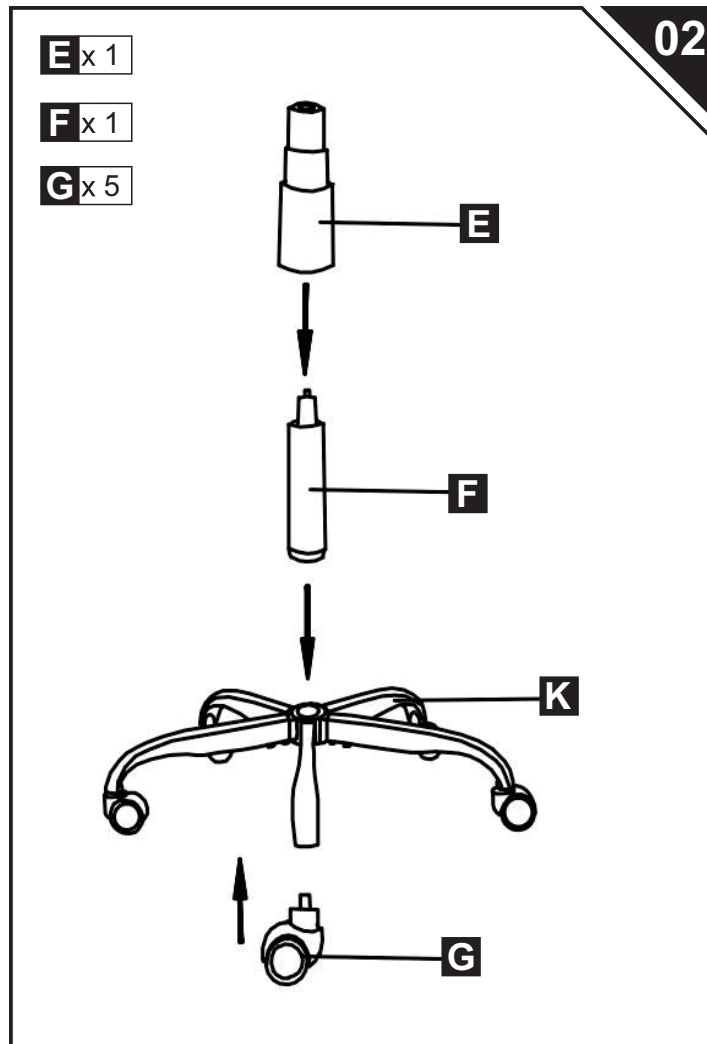
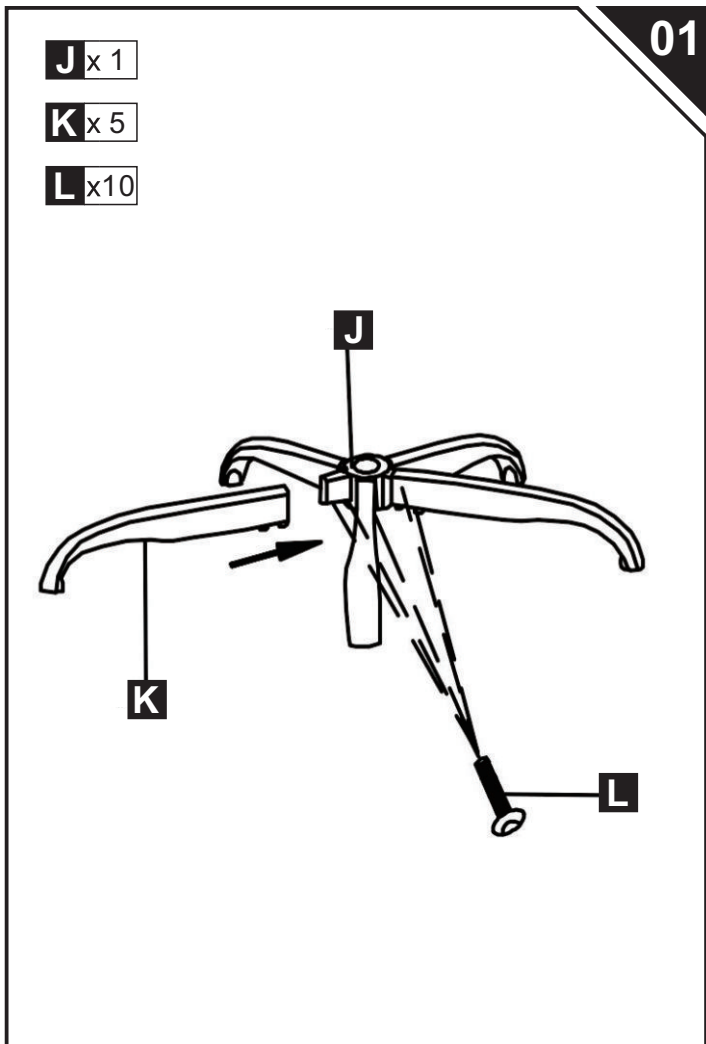

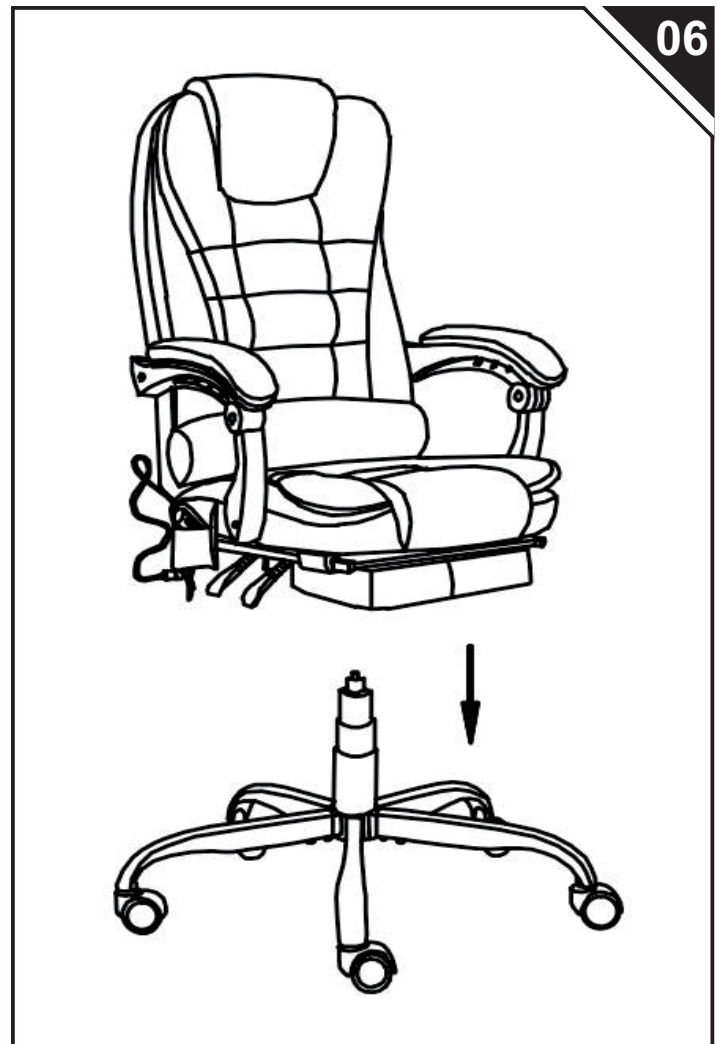
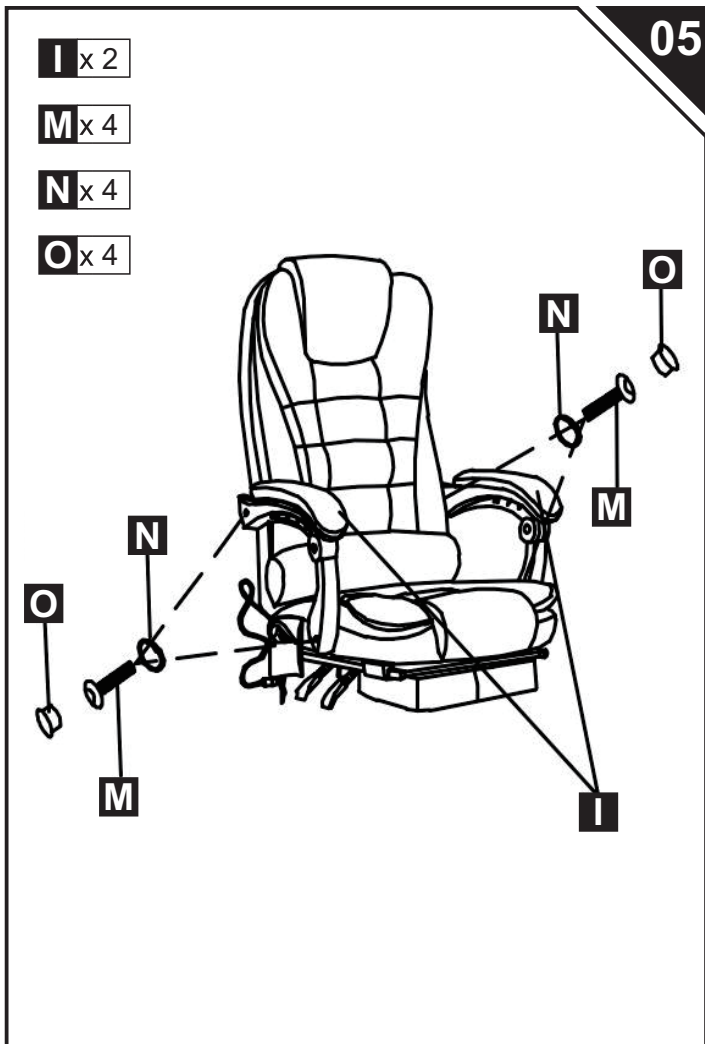
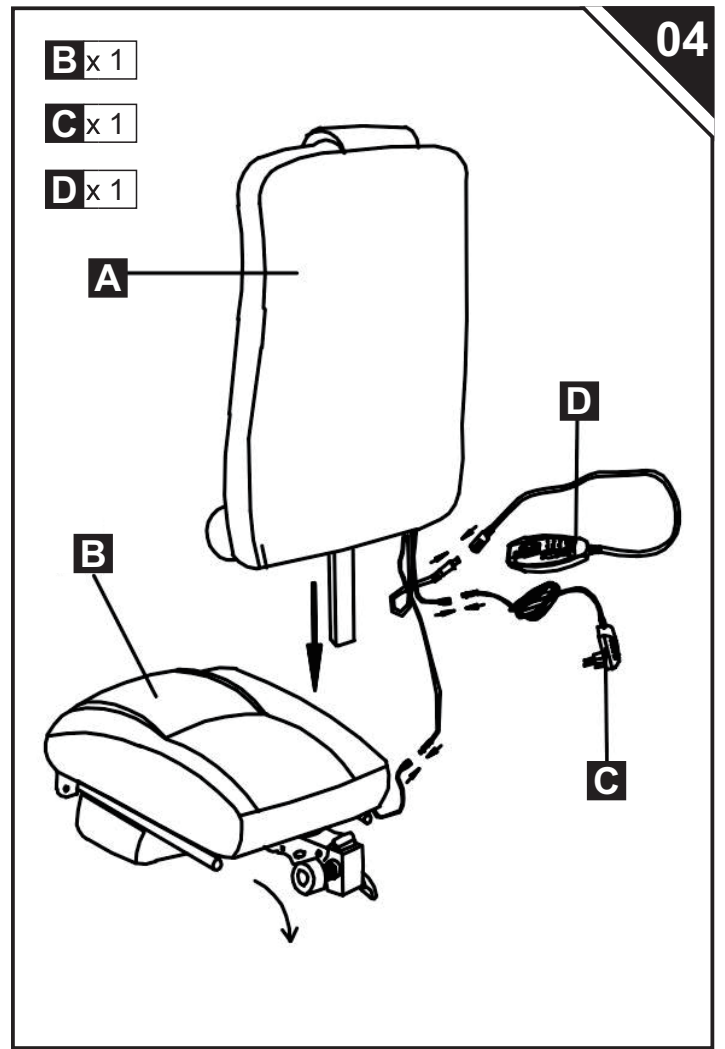
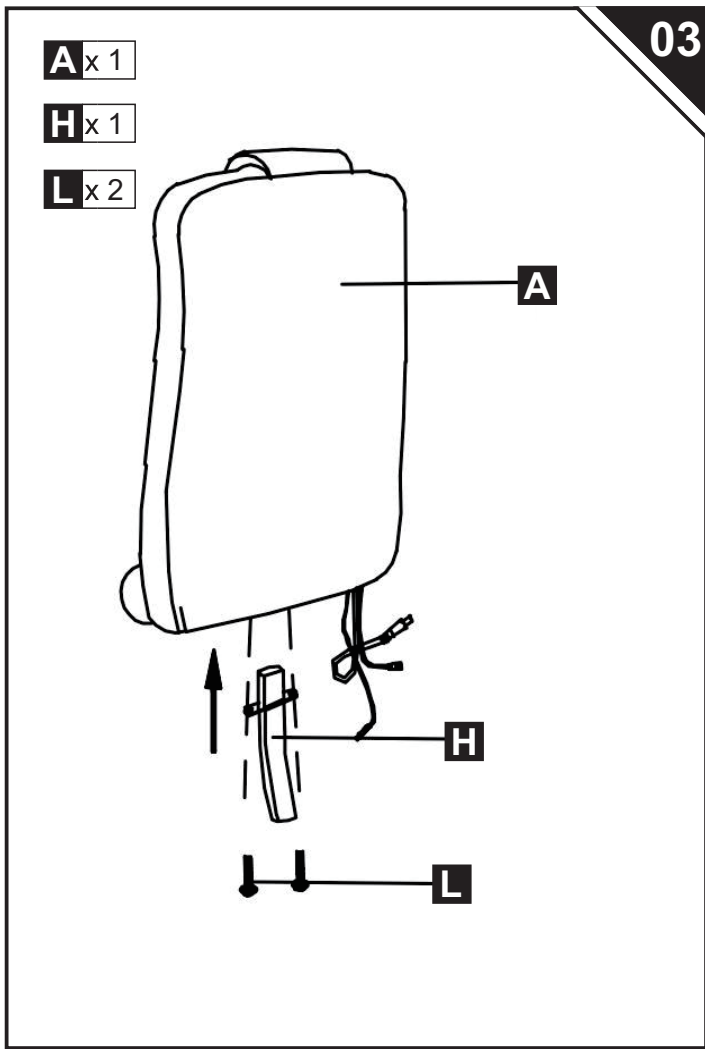

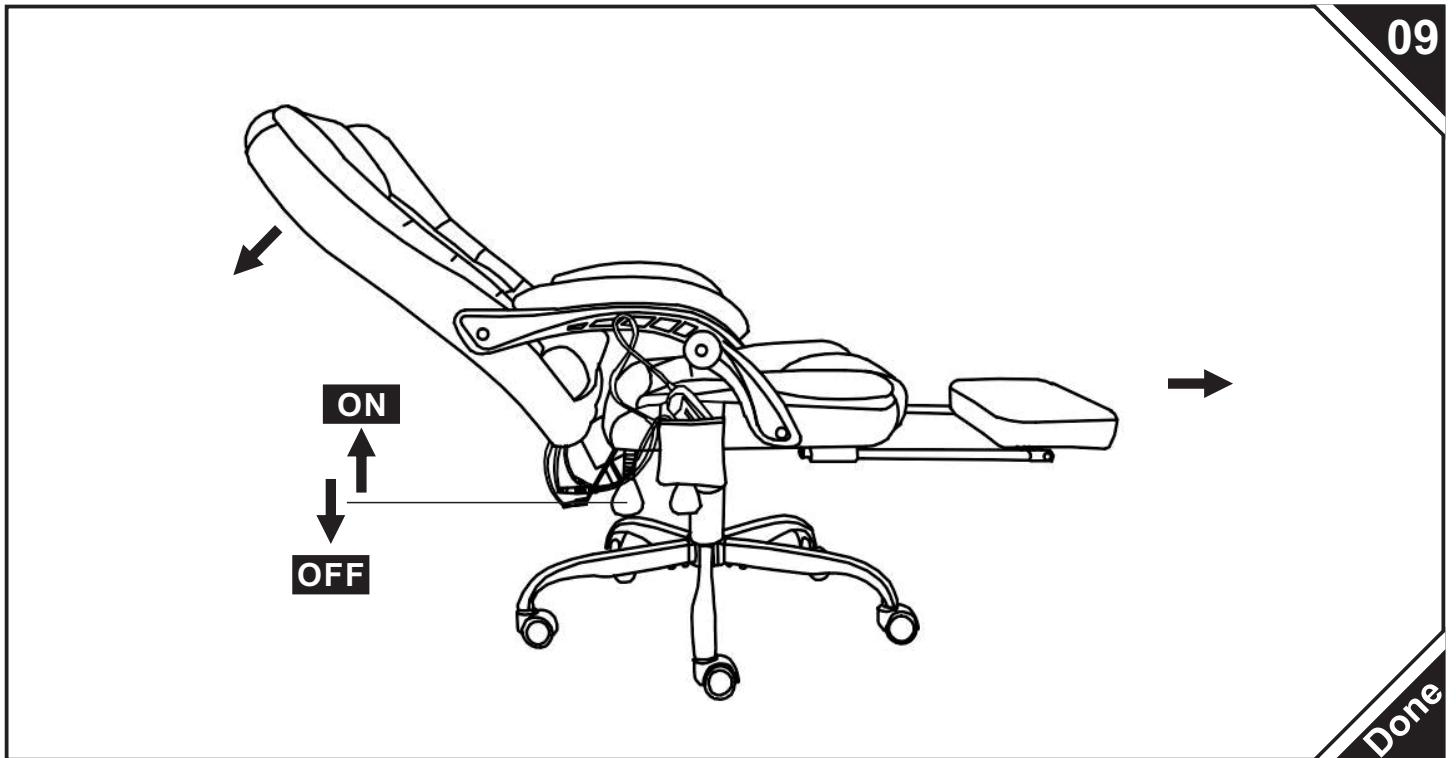
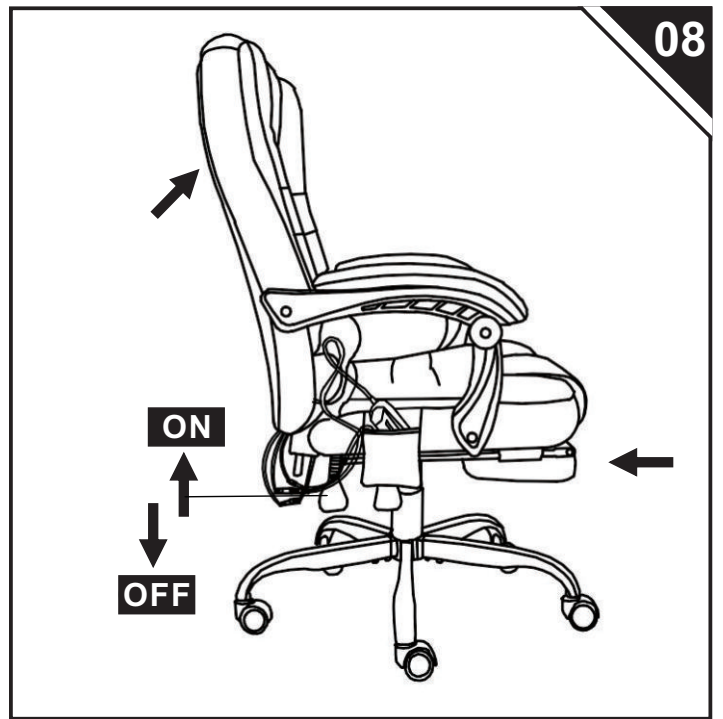
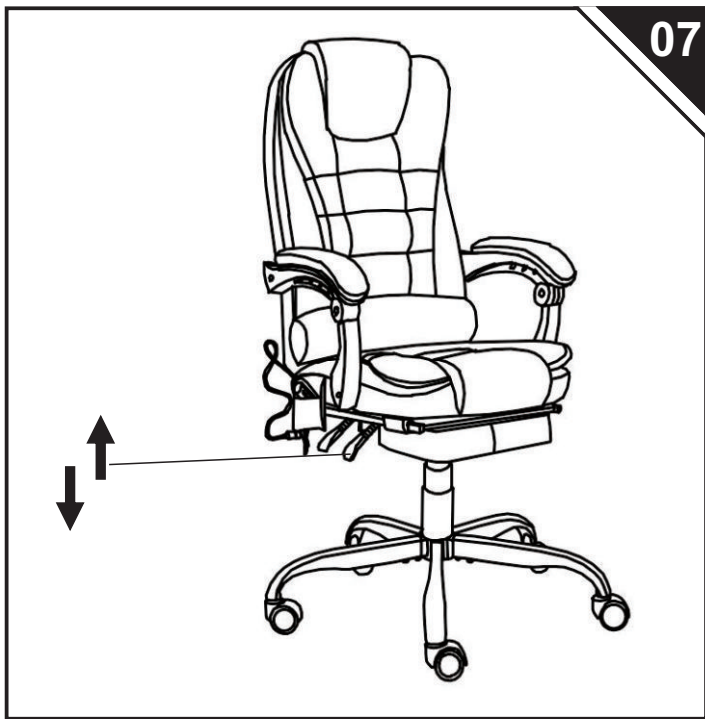

Done

Input voltage	100-240	V
Input AC frequency	50/60	Hz
Output voltage	12	V
Output current	1	A
Output power	12	W
Average active efficiency	85	%
Efficiency at low load (10 %)	76.58-75.32	%
No-load power consumption	0.074-0.099	W

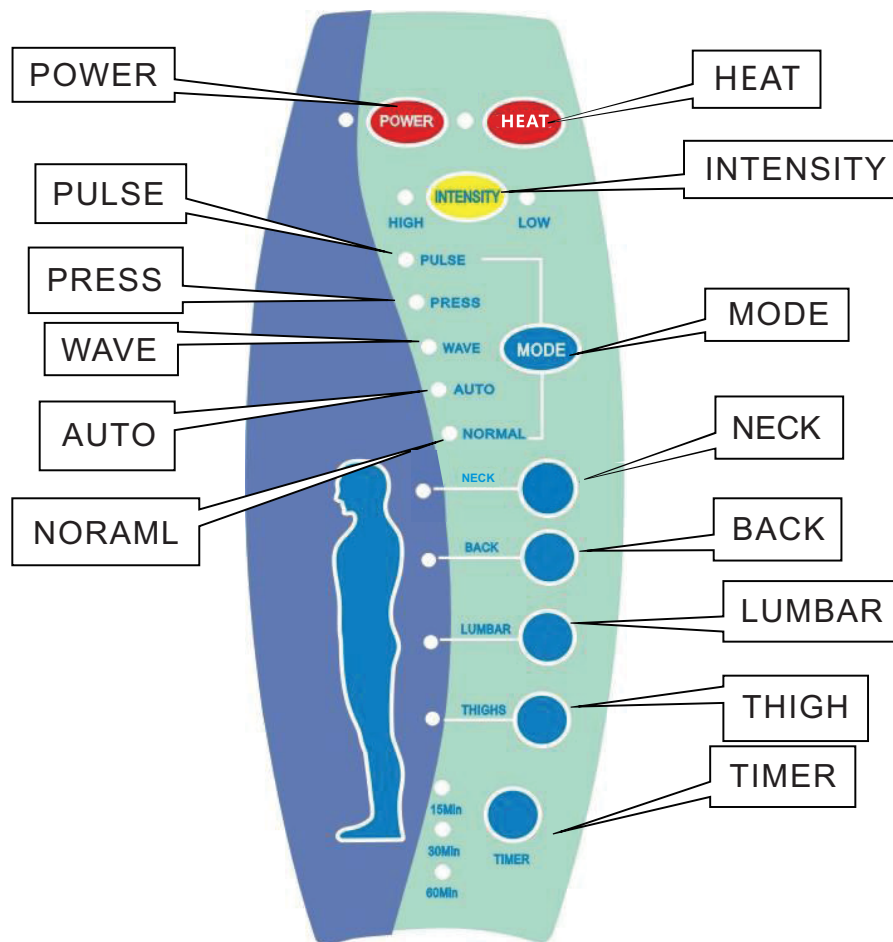

## I. Graphic presentation of Controller

1. POWER: turn on/off selection key
2. HEAT: heating on/off key
3. INTENSITY: strong/weak selection key.
4. MODE: working mode selection key
5. BACK: back massage function selection key
6. LUMBAR: lumbar massage function selection key
7. THIGH: thigh massage function selection key
8. TIMER: set working time key

## II. Operating Instructions

1. Insert the power into the DC socket
2. Press the POWER key to start the unit, when the unit will enter the first mode to run for 15min in the medium step, with all the corresponding indicators illuminated.
3. Press the HEAT to turn on the heating function.
4. Press the TIMER key, the unit's control time will switch between 15min, 30min and 60min.
5. Press the FUNCTION key to select different working modes(PULSE,PRESS,WAVE,AUTO,NORMAL)
6. Press the INTENSITY key to select the high and low the intensity of vibration.
7. Press the NECK,BACK,LUMBAR and THIGH key will to massage the different places of the body

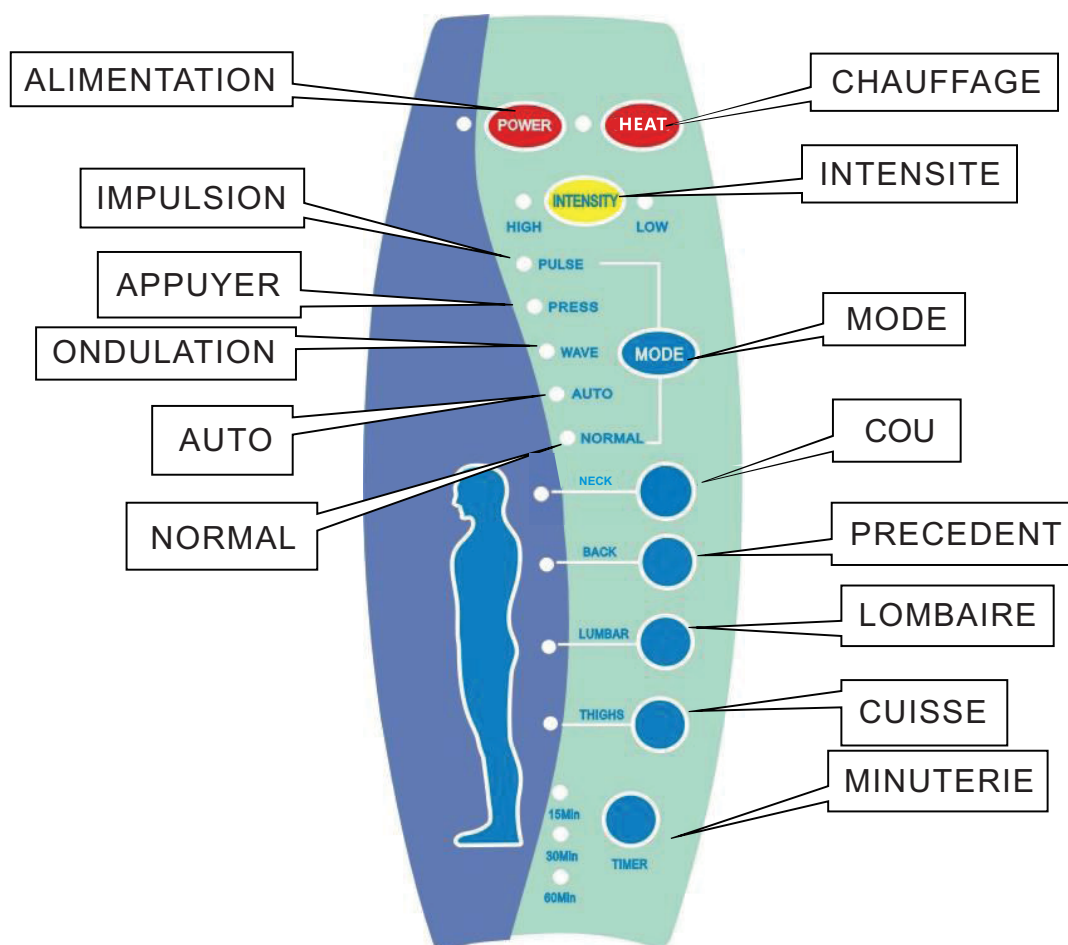

## I. Présentation graphique du contrôleur

1. ALIMENTATION : activer/désactiver la touche de sélection
2. CHAUFFAGE : touche marche/arrêt du chauffage
3. INTENSITE : touche de sélection forte/faible.
4. MODE : touche de sélection du mode de travail
5. DOS : touche de sélection de la fonction de massage du dos
6. LOMBAIRE : touche de sélection de la fonction de massage de lombaire
7. CUISSE : touche de sélection de la fonction de massage de cuisse
8. MUNUTERIE : définir la touche de temps de travail

## II. Instructions d'exploitation

1. Insérez la fiche d'alimentation dans la prise CC
2. Appuyez sur la touche ALIMENTATION pour démarrer l'appareil, lorsque l'appareil entrera dans le premier mode pour fonctionner pendant 15min dans l'étape moyenne, avec tous les voyants correspondants allumés.
3. Appuyez sur la touche CHAUFFAGE pour activer la fonction de chauffage.
4. Appuyez sur la touche MINUTERIE, le temps de contrôle de l'appareil passera entre 15min, 30min et 60min.
5. Appuyez sur la touche FONCTION pour sélectionner différents modes de travail (IMPULSION, PRESSE, ONDULATION, AUTO, NORMAL)
6. Appuyez sur la touche INTENSITÉ pour sélectionner la haute et la faible intensité des vibrations.
7. Appuyez sur la volonté de touche COU, DOS, LOMBAIRE et CUISSE pour masser les différents endroits du corps

US



001-877-644-9366  
customerservice@aosom.com

CA



001-855-537-6088  
customerservice@aosom.ca

UK



0044-800-240-4004  
enquiries@mhstar.co.uk

DE



0049-(0)40-88307530  
service@aosom.de

FR



0033-1-84166106  
contact@aosom.fr

ES



0034-931294512  
atencioncliente@aosom.es

IT



0039-0249471447  
clienti@aosom.it