

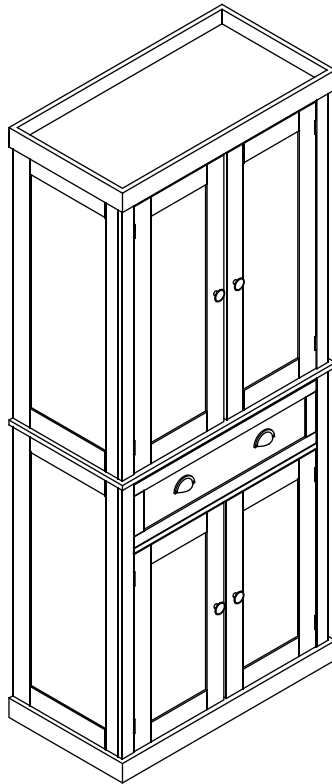

INcce012V02_UK_FR_ES_DE_IT

835-115



IMPORTANT, RETAIN FOR FUTURE REFERENCE: READ CAREFULLY

ASSEMBLY INSTRUCTION

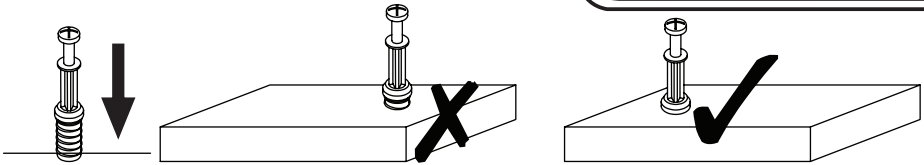

EN_QUICKFIT: Tighten quickfit until shoulder is flush with panel. Do not overtighten or undertighten.

FR_RACCORD RAPIDE: Faites serrer le raccord rapide jusqu'à ce que l'épaulement soit parfaitement encastré dans le panneau. Il ne faut ni trop serrer ni insuffisamment serrer.

ES_QUICKFIT: Apriete quickfit hasta que el hombro se descargue con el panel. NO lo sobreapriete ni lo apriete poco.

DE_QUICKFIT: Ziehen Sie den Quickfit fest, bis die Schulter mit der Platte bündig ist. Bitte nicht zu fest oder zu schwach anziehen.

IT_MONTAGGIO RAPIDO: Stringere il montaggio rapido fino a quando la spalla è a filo con il pannello, non stringere troppo o troppo poco.

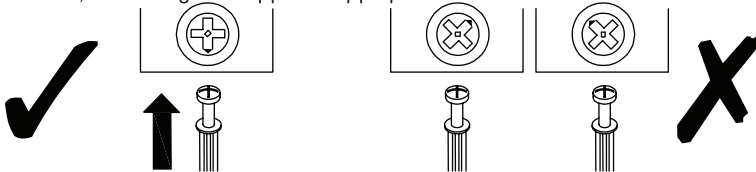

EN_CAM LOCK: When fitting cam lock, ensure starting position is correct before you insert connecting quickfit.

FR_SERRURE BATTEUSE: Avant d'insérer la serrure batteuse, veillez à la bonne orientation avant d'insérer le raccord rapide.

ES_CIERRE DE LA CÁMARA: Cuando instale el cierre de la cámara, asegúrese de que la posición de inicio es correcta antes de que inserte el quickfit conector.

DE_CAM-LOCK: Achten Sie bei der Montage des Cam-Locks auf die richtige Ausgangsposition, bevor Sie den Quickfit einsetzen.

IT_BLOCCAGGIO A CAMMA: Quando si monta il bloccaggio a camma, assicurarsi che la posizione iniziale sia corretta prima di inserire il montaggio rapido di collegamento.

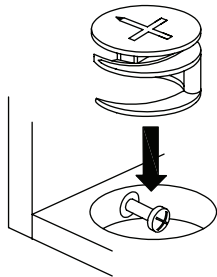

EN_Quickfit head should be in the centre of the cam lock when the two panels are joined.

Cam lock should be inserted before quickfit.

FR_Lorsque les deux panneaux sont assemblés, la tête du raccord rapide doit reposer au centre de la serrure batteuse. Il faut insérer la serrure batteuse avant le raccord rapide.

ES_El cabezal del quickfit debe estar en el centro del cierre de la cámara cuando se unan los dos paneles.

Se debe insertar el cierre de la cámara antes que el quickfit.

DE_Der Quickfit-Kopf sollte sich in der Mitte des Cam-Locks befinden, wenn die beiden Platten zusammengefügt sind.

Der Cam-Lock sollte vor dem Quickfit eingesetzt werden.

IT_La testa del montaggio rapido deve trovarsi al centro del bloccaggio a camma quando i due pannelli sono uniti.

Il Bloccaggio a Camma deve essere inserito prima del montaggio rapido.

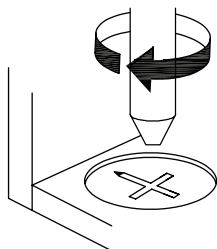

EN_Turn cam lock clockwise to tighten.

FR_Faites tourner la serrure batteuse dans le sens des aiguilles d'une montre pour la resserrer.











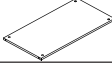

ES_Gire el cierre de la cámara en sentido horario para apretarlo.

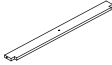
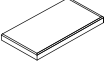
DE_Drehen Sie den Cam-Lock im Uhrzeigersinn, um ihn festzuziehen.

IT_Ruotare il bloccaggio a camma in senso orario per stringere.

PACKING DETAILS:TOTAL 2 BOXES









BOX 1/2:













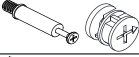







PART NO.	PARTS	QTY
1		x1
4		x1
5		x1
9		x1
12		x1
13		x1
15		x1
16		x1
17		x1
18		x1
19		x1
20		x1
21		x1
22		x1

This product is packed in 2 outer boxes. Please install it after all. Thank you!



PACKING DETAILS:TOTAL 2 BOXES

BOX 2/2:

PART NO.	PARTS	QTY
2		x1
3		x1
6		x2
7		x1
8		x1
10		x1
11		x1
14		x1
22		x2

PART NO.	PARTS	QTY
A		x8 +1(spare)
B		x4 +1(spare)
C		x26 +1(spare)
D		x8 +1(spare)
E		x36 +2(spare)
F		x2
G		x2
H		x4
I		x4 +1(spare)
J		x2
K		x4
L		x12 +1(spare)
M		x2 +1(spare)
N		x8
O		x6 +1(spare)
P		x12 +1(spare)
Q		x4
R		x2
S		x2 +1(spare)
T		x2 +1(spare)

This product is packed in 2 outer boxes.
Please install it after all.Thank you!

U		x4 +1(spare)
V		x26+1(spare)

Assembly Instructions

1

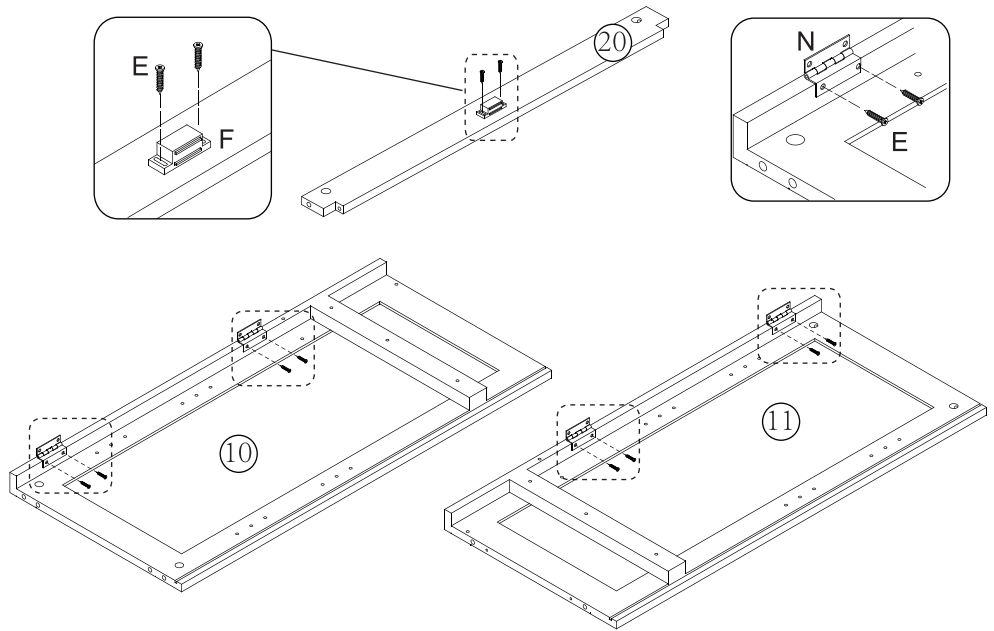

2

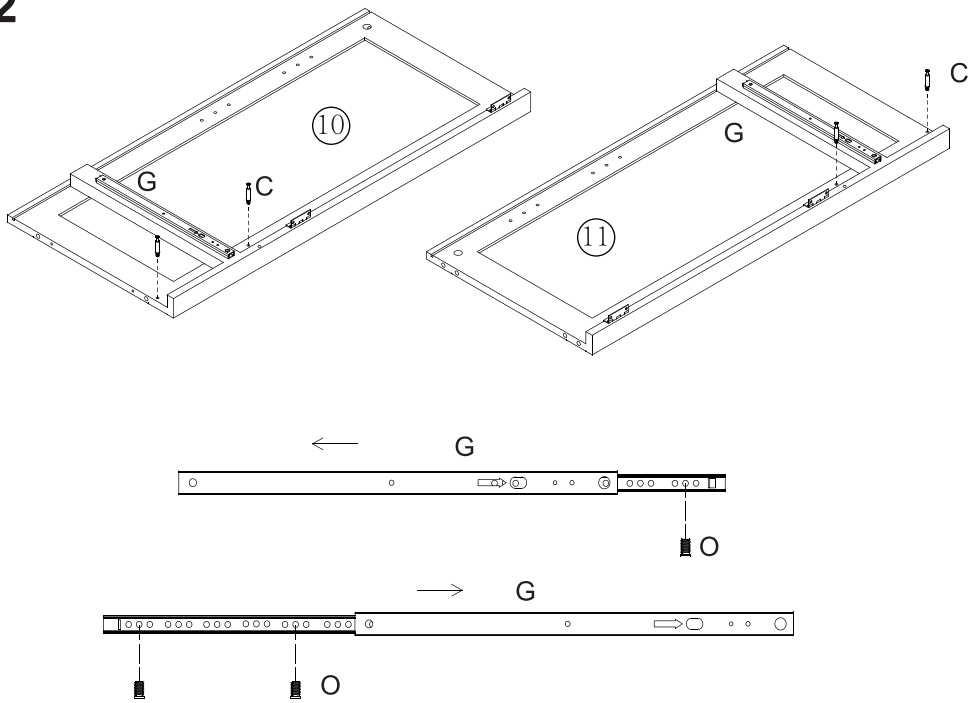

Assembly Instructions

3

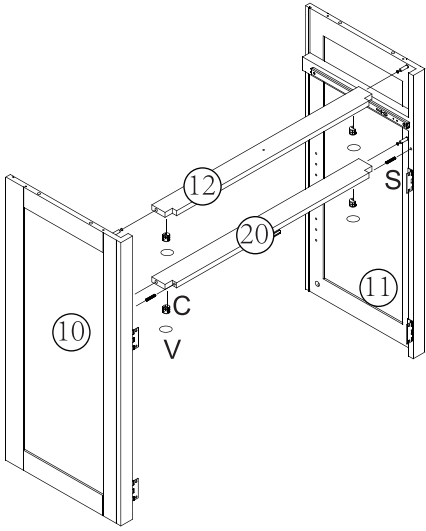

4

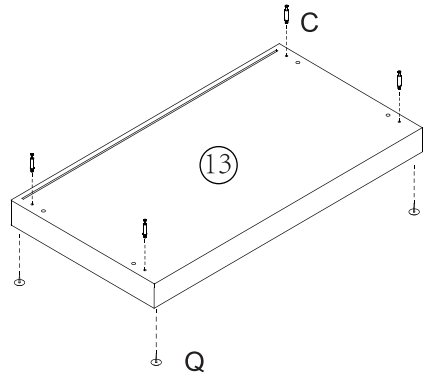

5

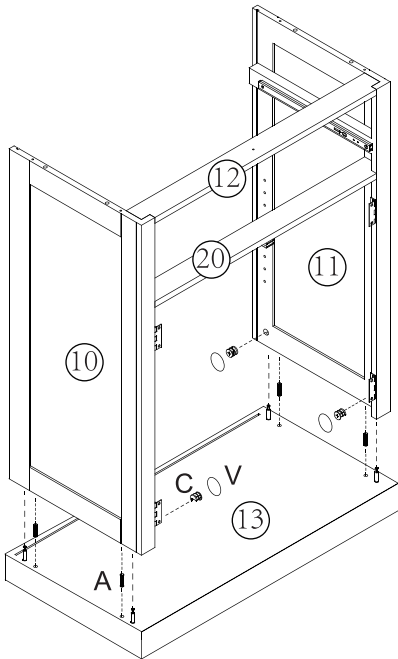

6

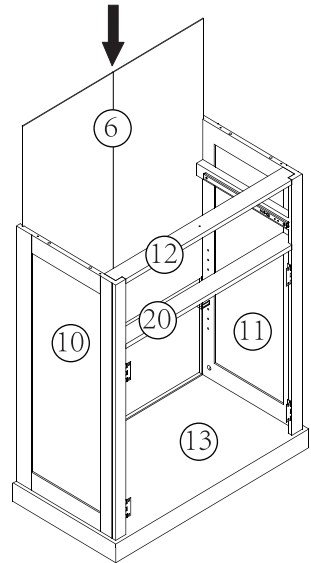

Assembly Instructions

7

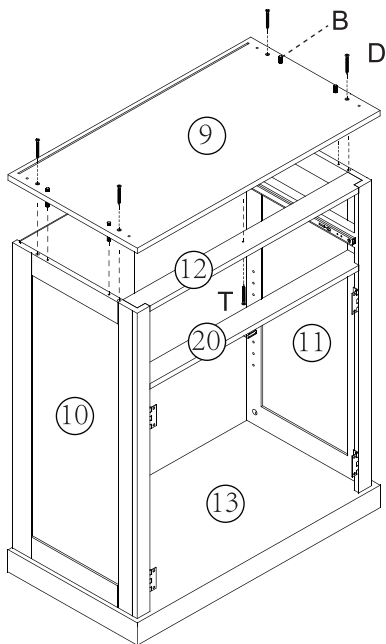

8

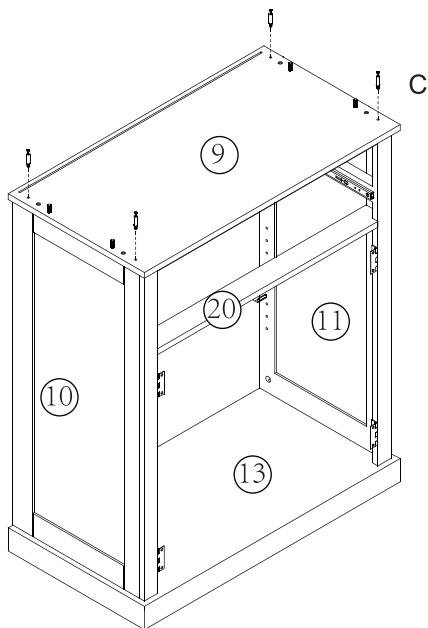

Assembly Instructions

9

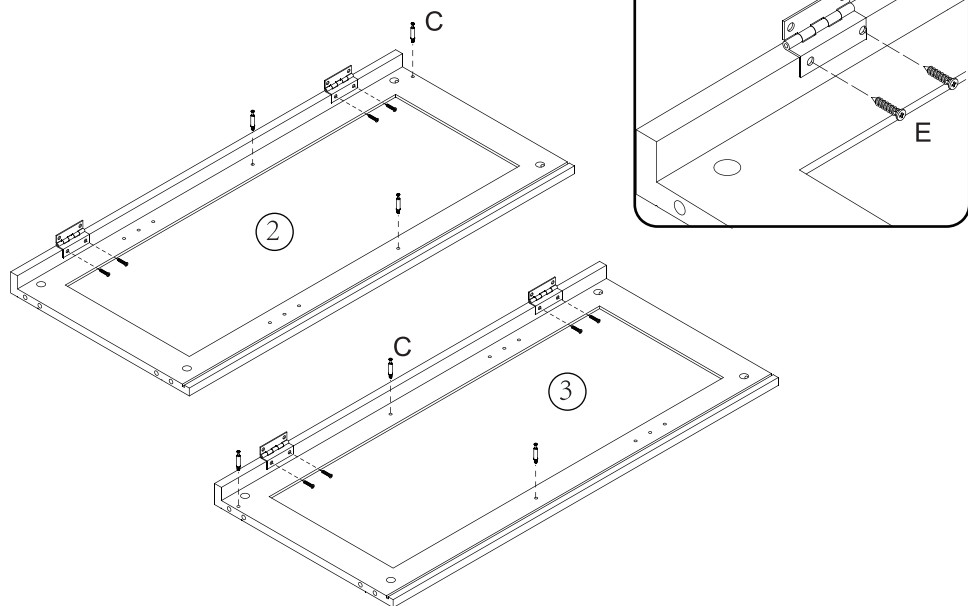

10

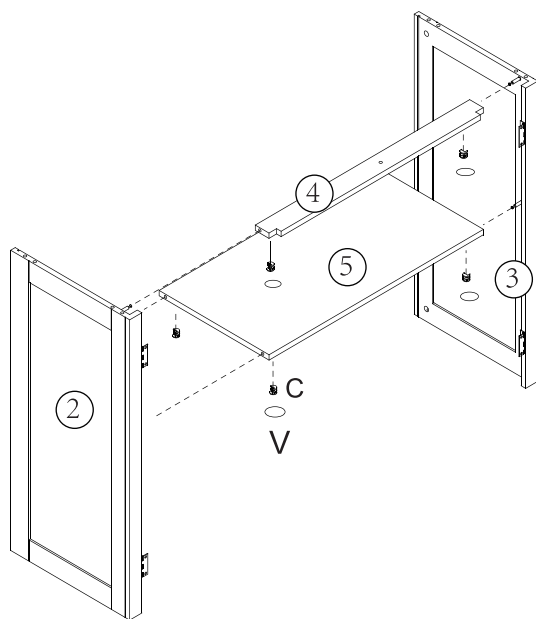

Assembly Instructions

11

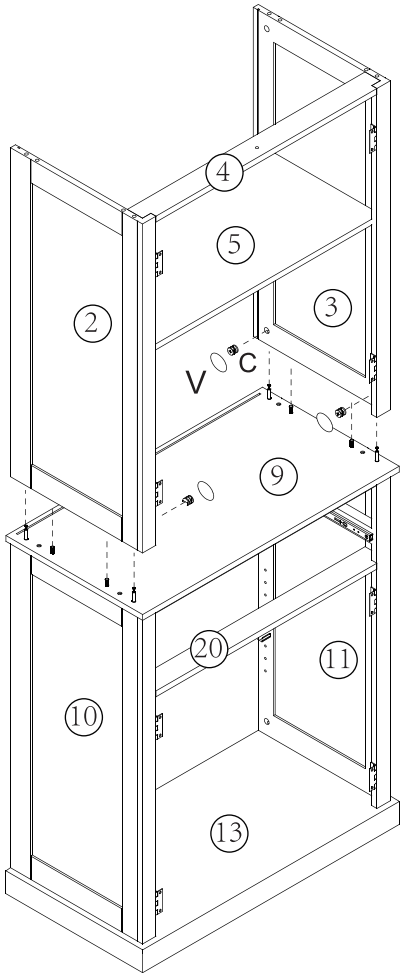

12

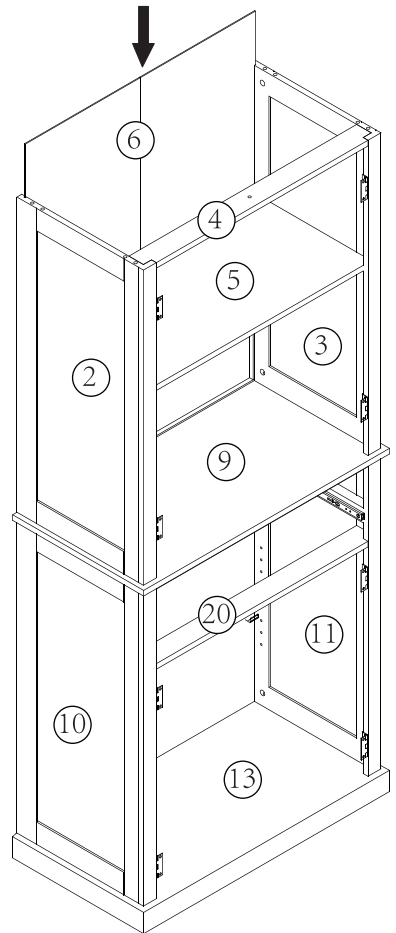

Assembly Instructions

13

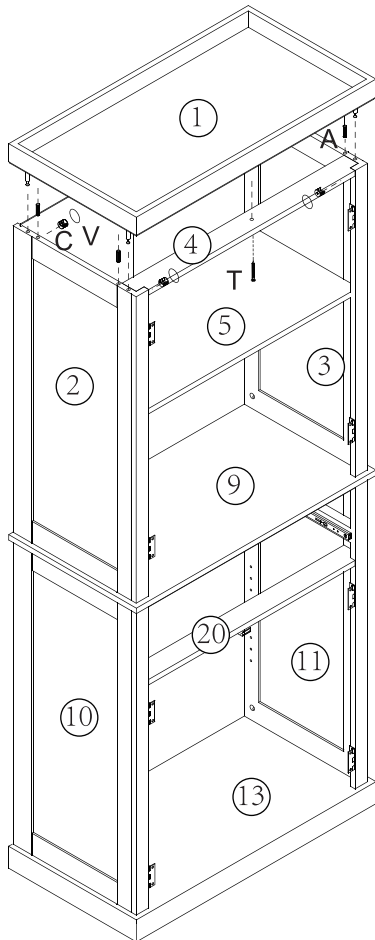
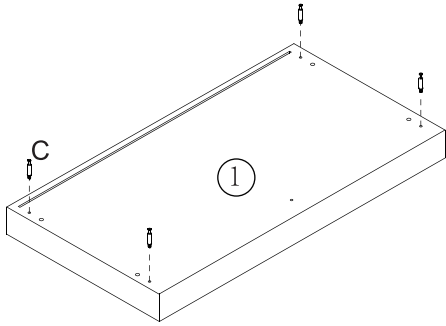

14

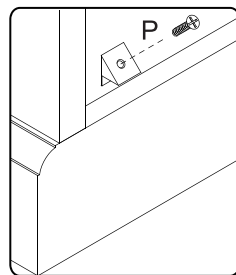
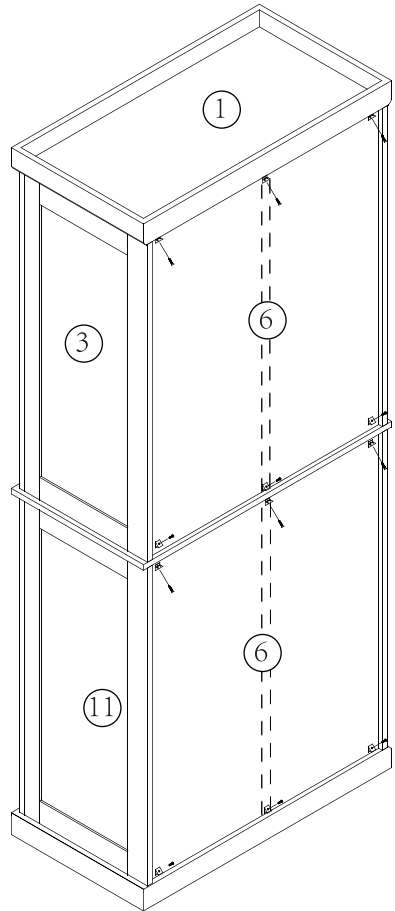

Assembly Instructions

15

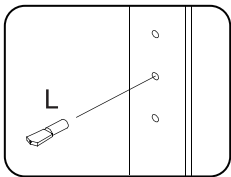
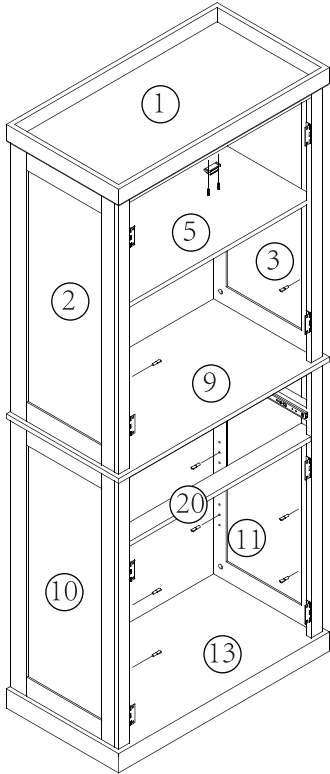
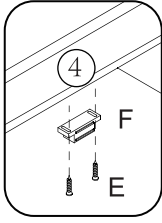

16

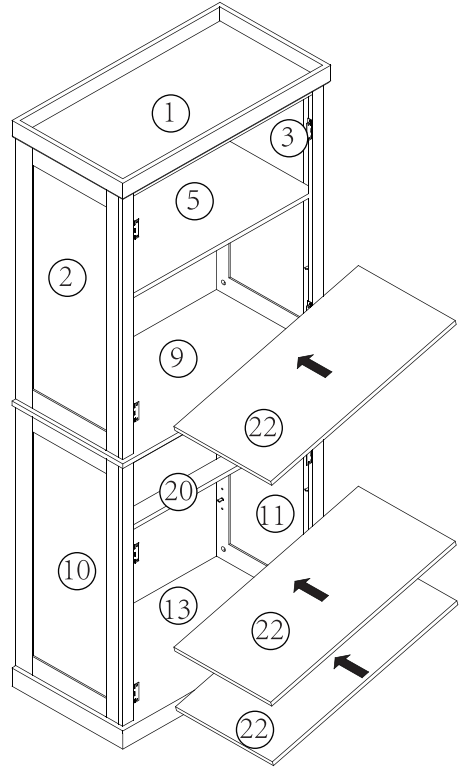

17

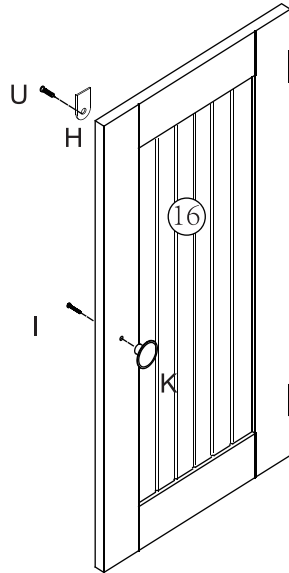
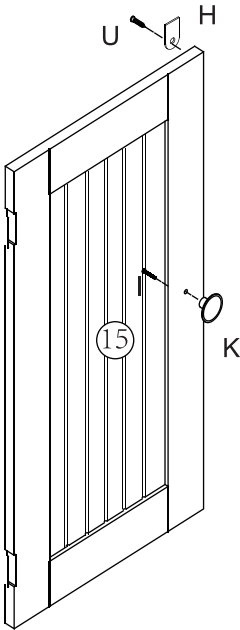
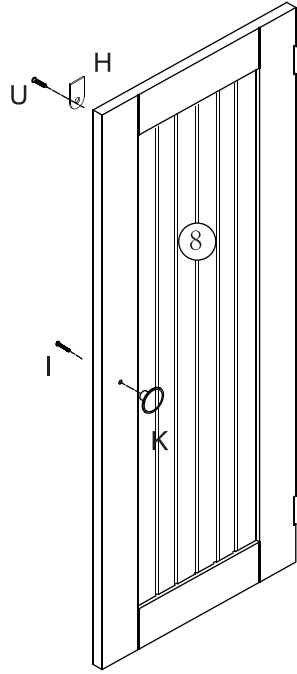
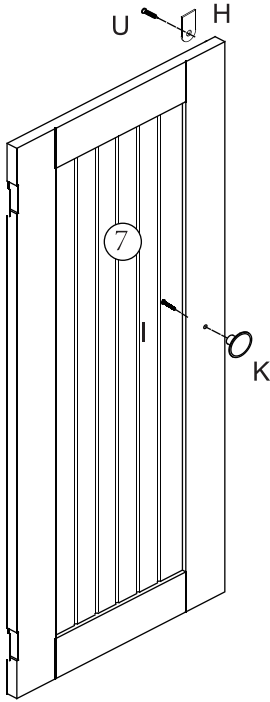

18

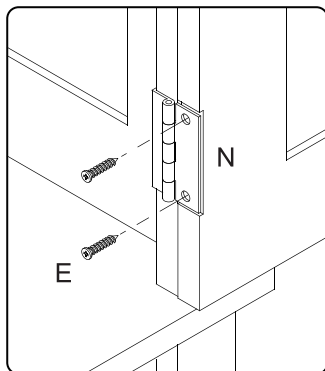
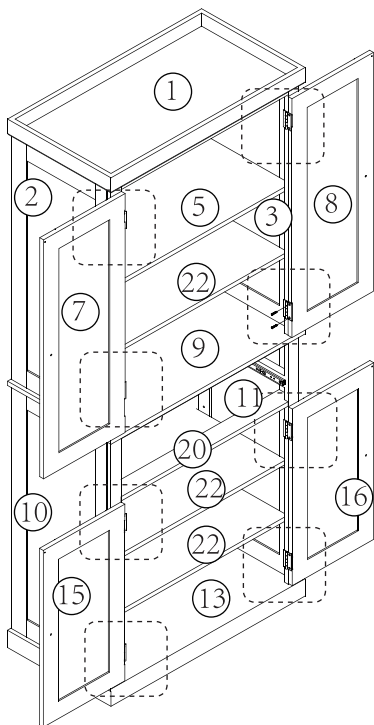

19

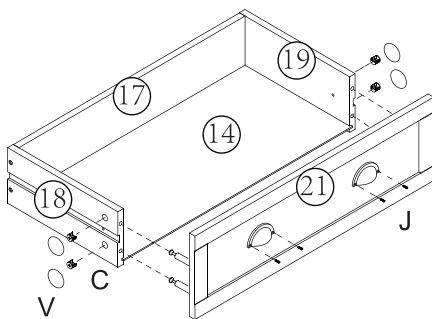
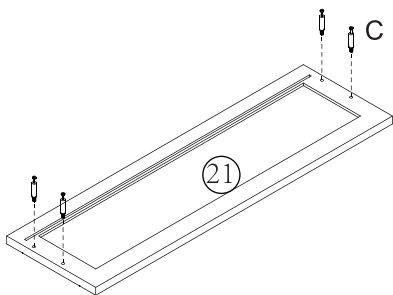
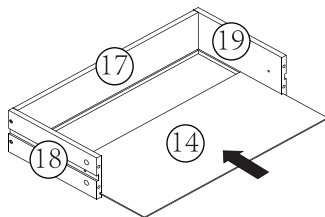
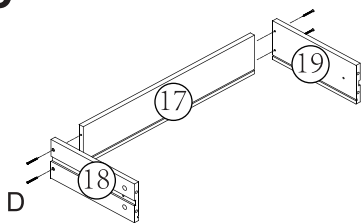

20

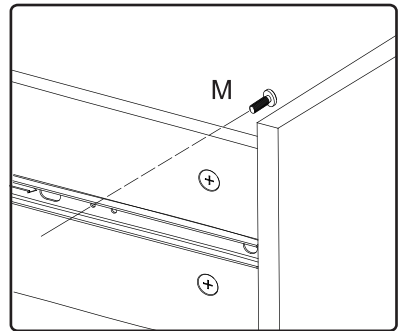
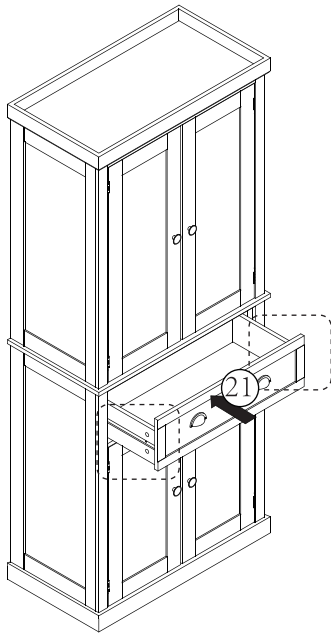

21

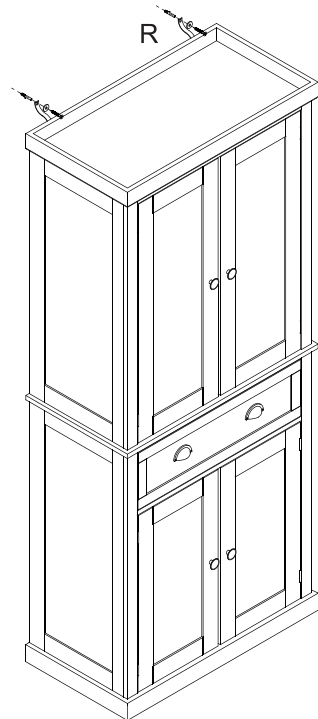
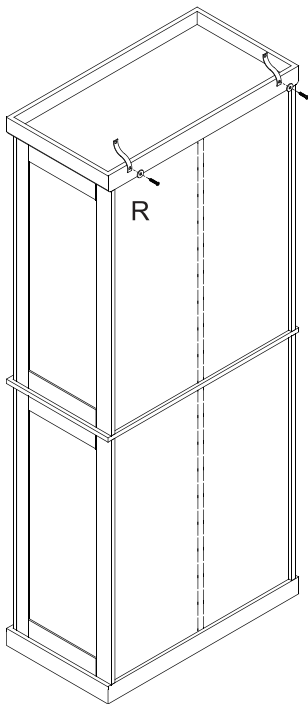

IMPORTER**EN**

MH STAR UK LTD
Unit 27, Perivale Park,
Horsenden lane South
Perivale, UB6 7RH
MADE IN CHINA

IMPORTATEUR**FR**

MH FRANCE
2 Rue Maurice Hartmann
92130 Issy Les Moulineaux
France
FABRIQUÉ EN CHINE

IMPORTADOR POR**ES**

SPANISH AOSOM, S.L.
C. roc gros no.15, 08550 Els hostalets de Balenya, Spain
B66295775
www.aosom.es
atencioncliente@aosom.es
TEL: 931294512
HECHO EN CHINA

IMPORTEUR**DE**

MH Handel GmbH
Wendenstraße 309
D-20537 Hamburg
Germany
IN CHINA HERGESTELLT

IMPORTATO DA**IT**

AOSOM Italy srl
Centro Direzionale Milanofiori
Strada 1 Palazzo F1
20057 Assago (MI)
P.I.: 08567220960
FATTO IN CINA