

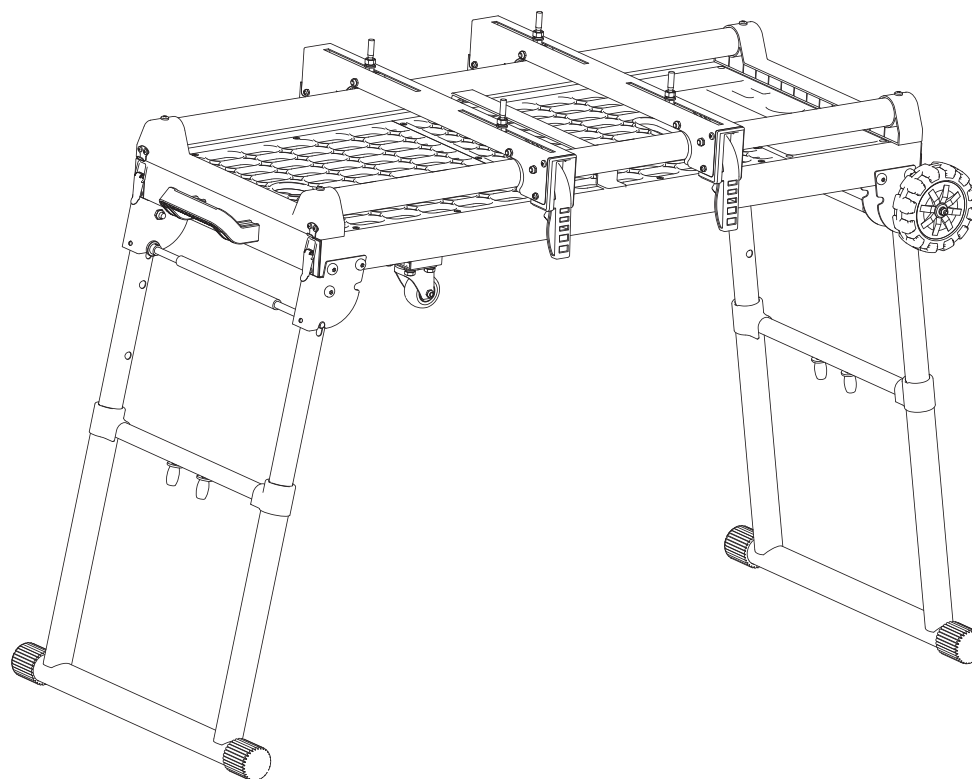

INcea055_US_FR_IT

B71-053_B71-053V80



IMPORTANT, RETAIN FOR FUTURE REFERENCE: READ CAREFULLY

ASSEMBLY INSTRUCTION

COMPONENTS

Ensure All components are present. If any components are missing, do not proceed with assembly.

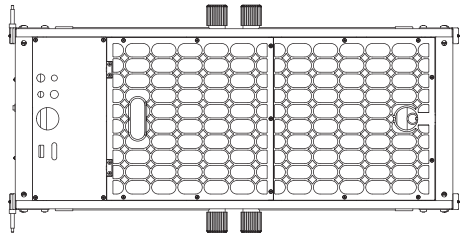

A

B

C

D

E



F

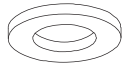

G



H



I



J



K

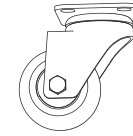

L

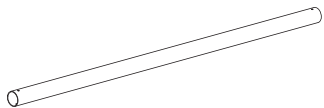

M

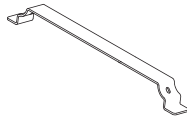

N

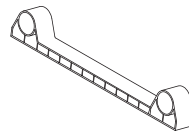

O

Part	Description	Qty
------	-------------	-----

A.	Stand	x1
B.	Handle	x1
C.	M6 Nut	x4
D.	M6x35	x2
E.	5" Wheel	x2
F.	Ø6 Washer	x2
G.	Ø8 Washer	x8
H.	M8 Spring Washer	x8
I.	M8x16	x8
J.	Tool Mount	x2
K.	Screw	x6
L.	Swivel Wheel	x2
M.	Top Tube	x2
N.	Central Support	x1
O.	Plastic Base	x2

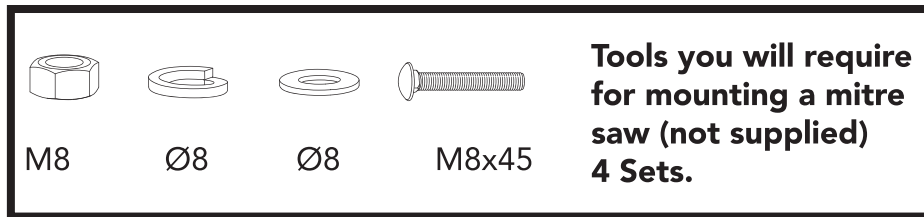
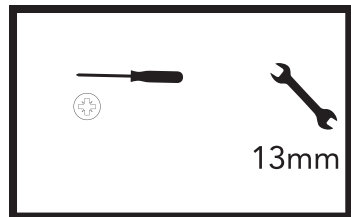

Tools you will require for mounting a mitre saw (not supplied) 4 Sets.

ASSEMBLY

WARNING Exercise caution. There is a potential for finger pinch/entrapment.

Components required to complete this assembly step.

I x8

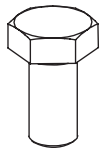

G x8

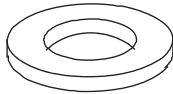

H x8



L x2



- Lay the stand (A) top surface on the floor
- Press the Leg Lock Lever and lift leg until the lever clicks into place
- Use **M8x16 bolt (I)** and **Ø8 Washer (G)** to assemble the **Swivel Wheels (L)**
- Lift the stand

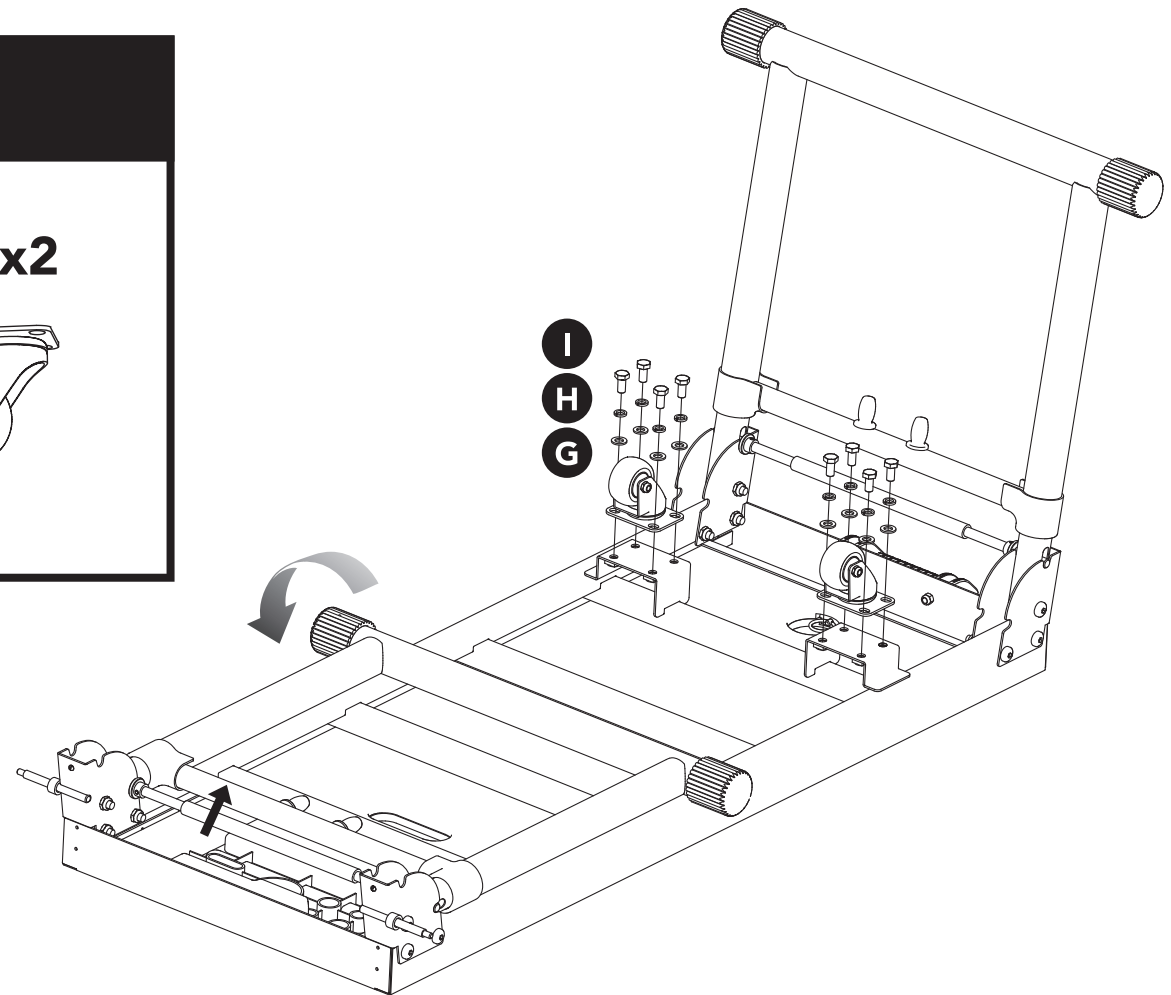

ASSEMBLY

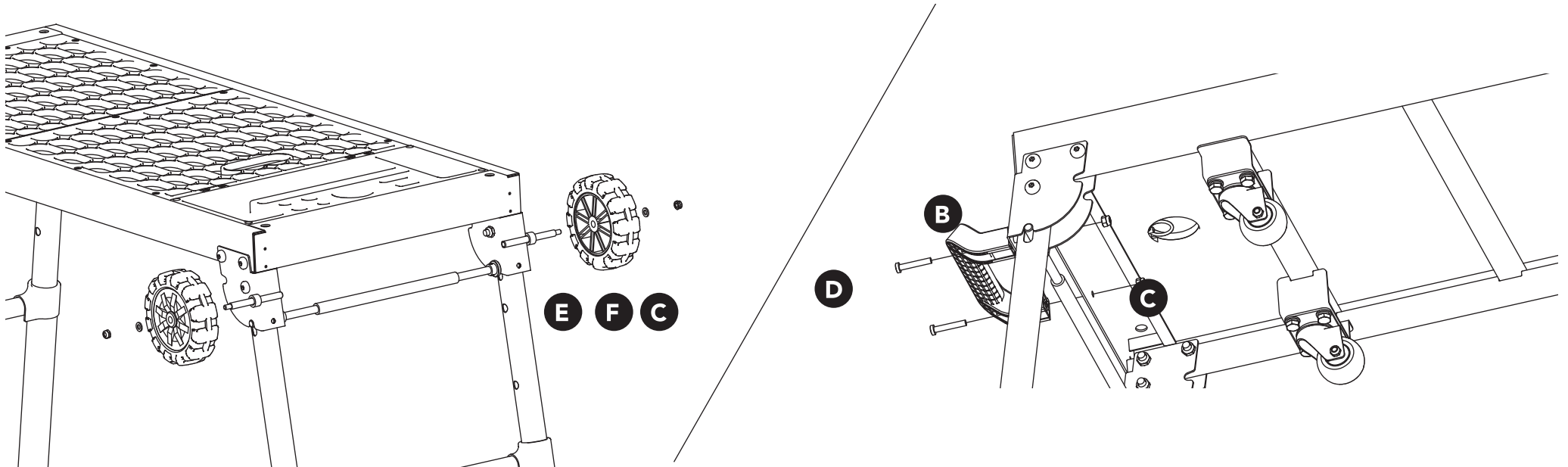

Components required to complete this assembly step.

F x2

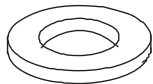

E x2



C x4



D x2

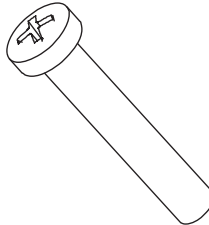

B x1

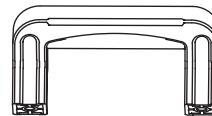

- Use the **M6 Nut (C)** and **Ø6 Washer (F)** to assemble the **5" Wheel (E)** to the axle.
- Use the **M6x35 Bolt (D)** and **M6 Nut (C)** to assemble the **Handle (B)**.

ASSEMBLY

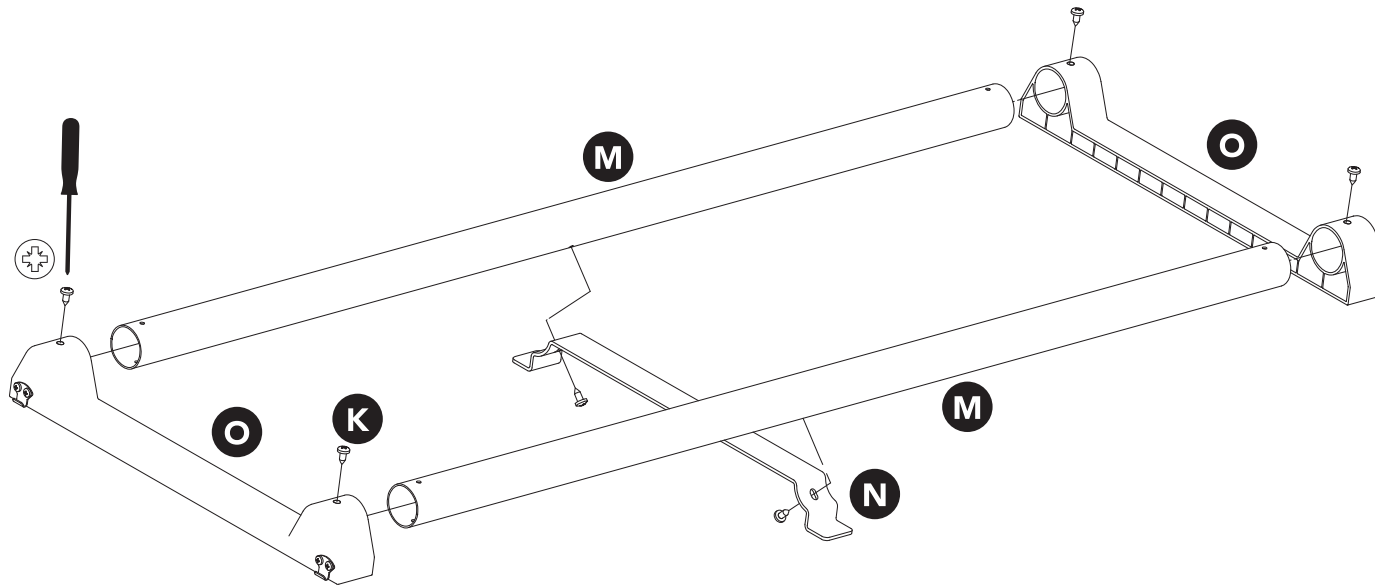

Components required to complete this assembly step.

M x2

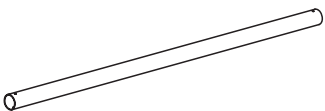

O x2

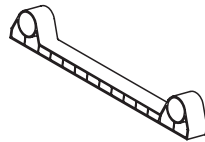

N x1

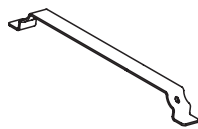

K x6

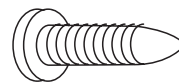

- Insert the **Top Tube (M)** into the **Plastic Base (O)** and fix with the **Screws (K)**
- Attach the **Central Support (N)** to the **Top Tube (M)** with the **Screws (K)**

ASSEMBLY

- Put the assembled work top onto the stand and fix it by the 4 lock catches.

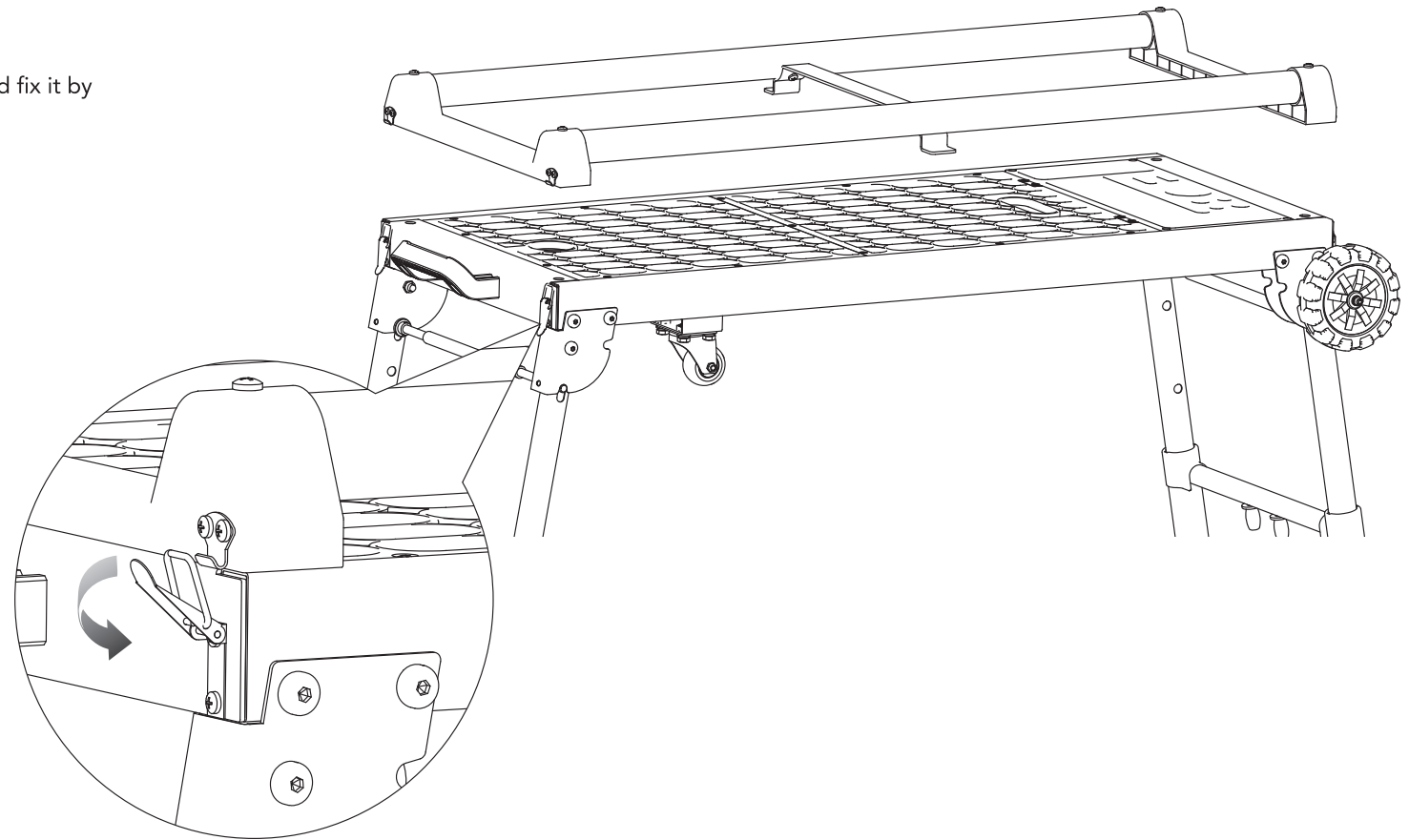

ASSEMBLY SETTING THE HEIGHT

- Clench the button inside and pull the bench up and down to adjust to the desired height.
- Ensure the locking pin locks securely at the new height.

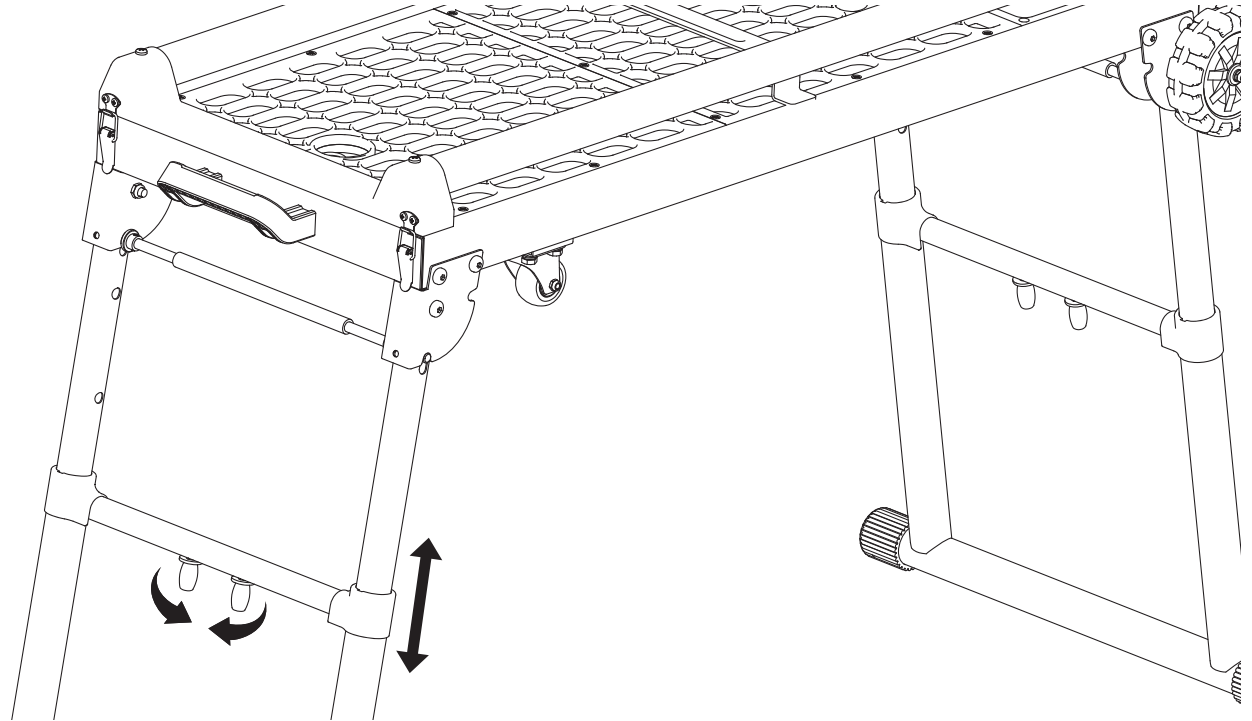

MOUNTING A MITRE SAW TO THE STAND

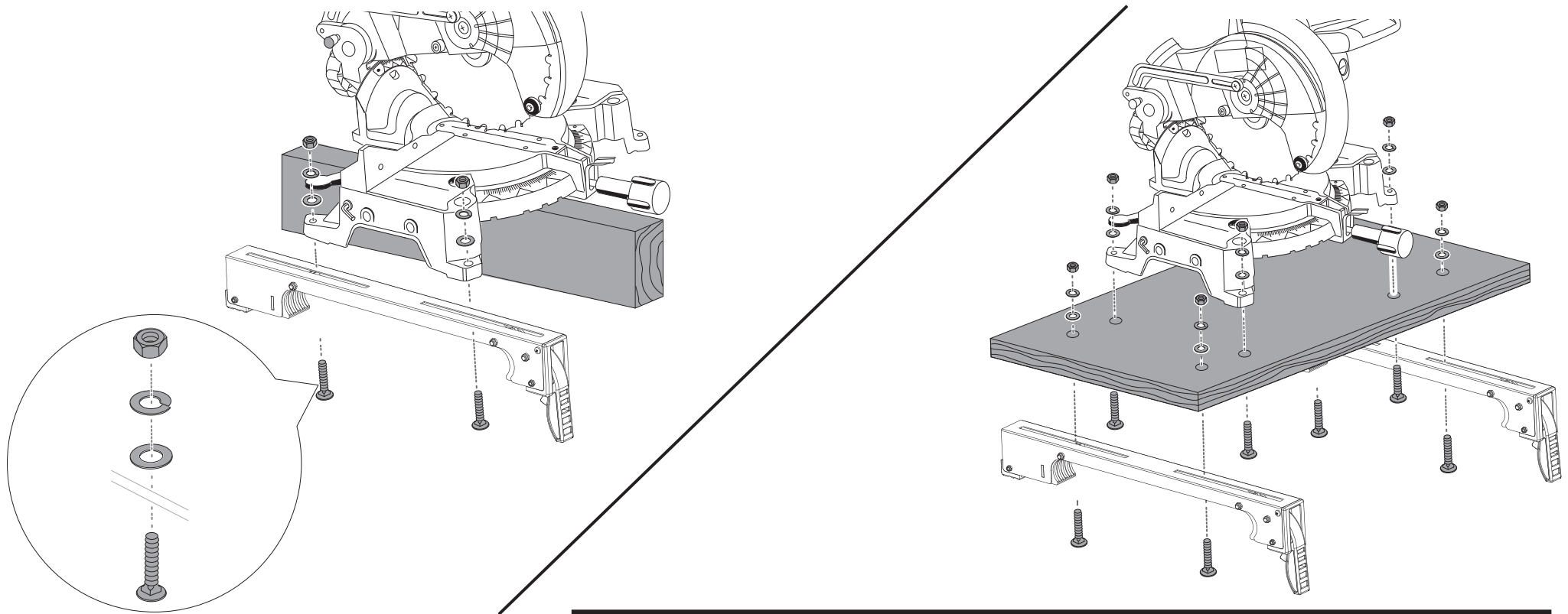

- Unplug the saw and the saw arm in the downwards position.
- Place a tool mount underneath the saw, aligning the mounting holes on the mitre saw base with the slot in the top of the tool mount.
- Fix the carriage bolt up through both the tool mount and the mounting hole on the saw.
- Secure in place using a flat washer. Lock the washer and nut, repeat through the other end of the tool mount.

Components required to complete this assembly step (not supplied)

x8

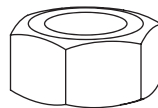

x8



x8



x8

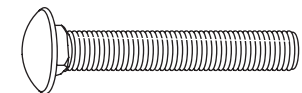

MOUNTING A MITRE SAW TO THE STAND

- Use the Handles located at the rear of the tool mounts to aid in installing or removing saw and bracket assembly
- Lift the saw and tool mount assembly, allowing the assembly to tilt slightly toward your body
- Hook the front edge of the tool mount assembly onto the front rail of the stand.
- Lower the tool mount assembly to allow the rear edge of the tool mount to seat fully over the rear rail

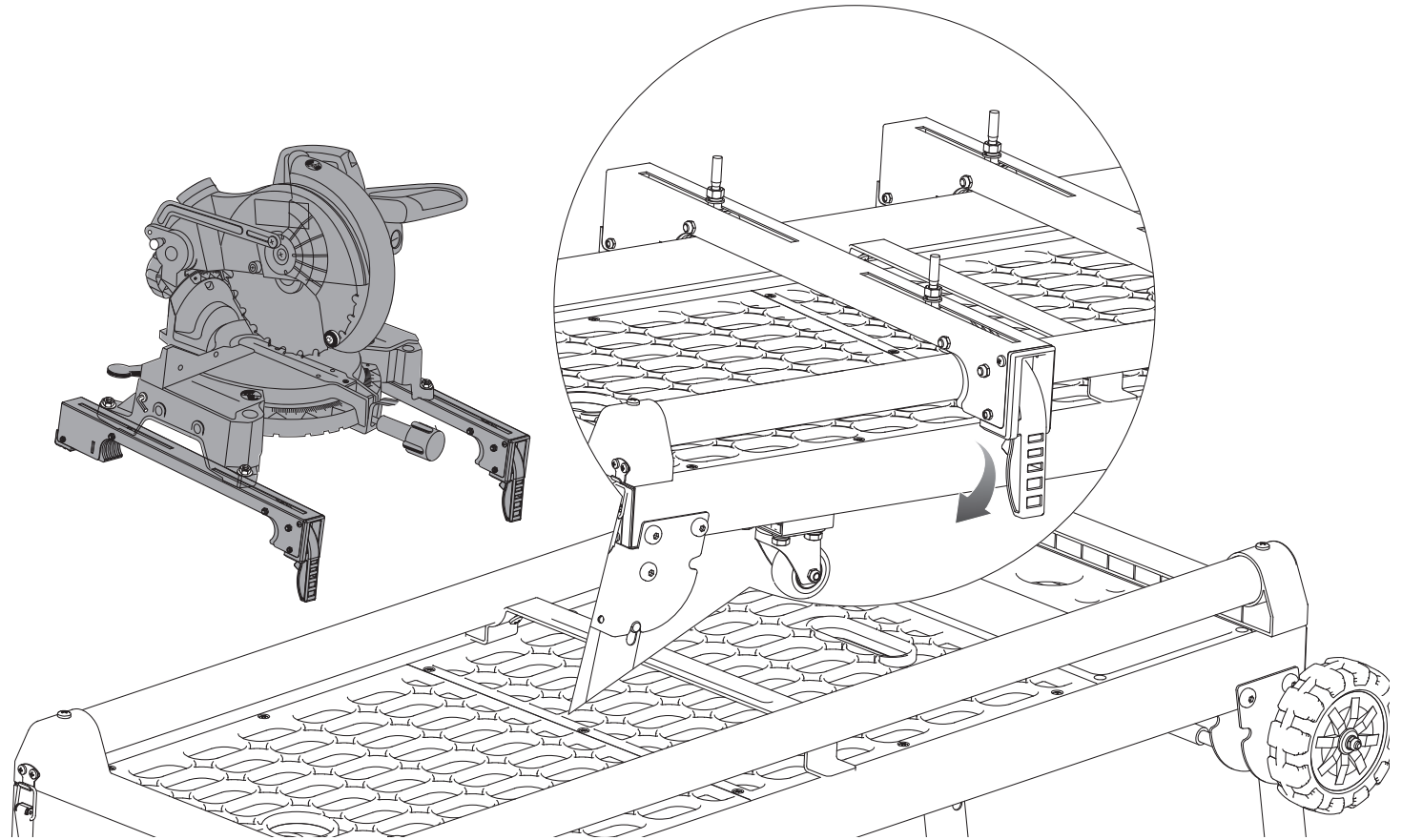

UNMOUNTING A MITRE SAW FROM THE STAND

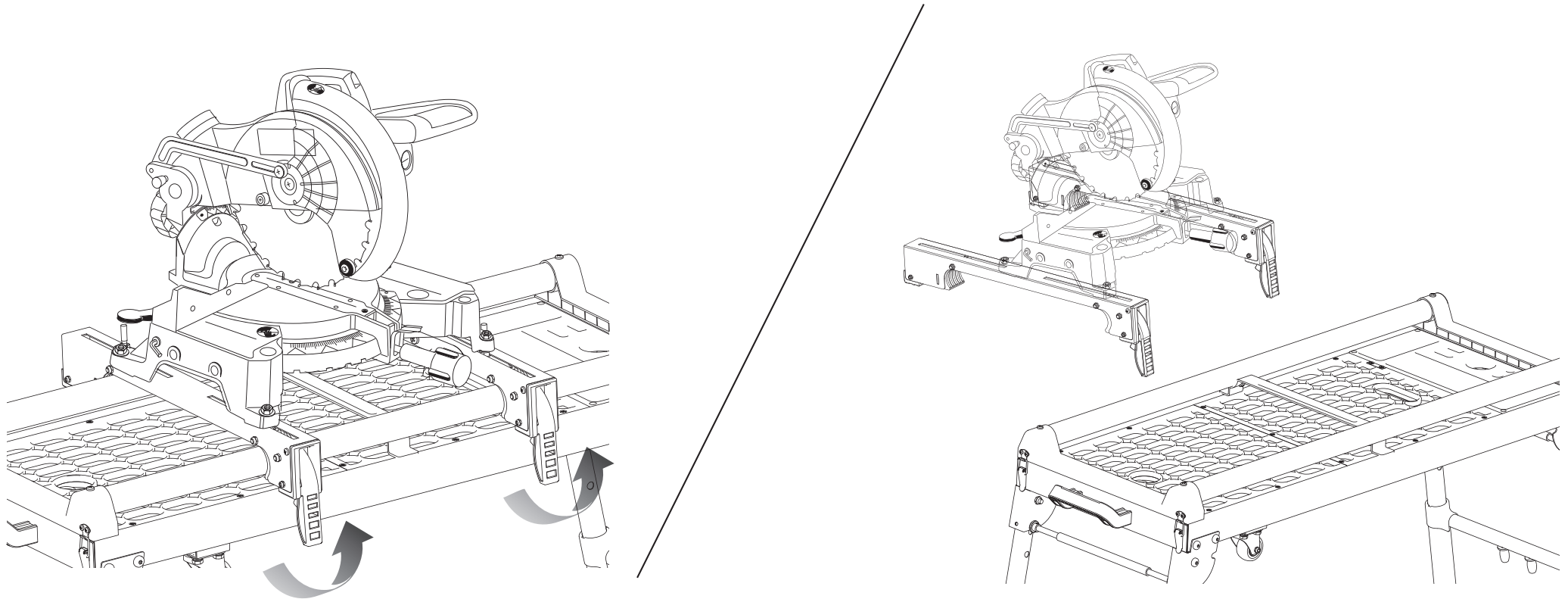

- Raise the **Locking Levers (J)** to unlock the saw and the tool mounts
- Grasp the handles on either side of the assembly and lift away from the rear rail of the stand to disengage
- With the assembly tilted slightly toward you, lift the front part of the assembly to disengage from the front of the rail stand

ASSEMBLY

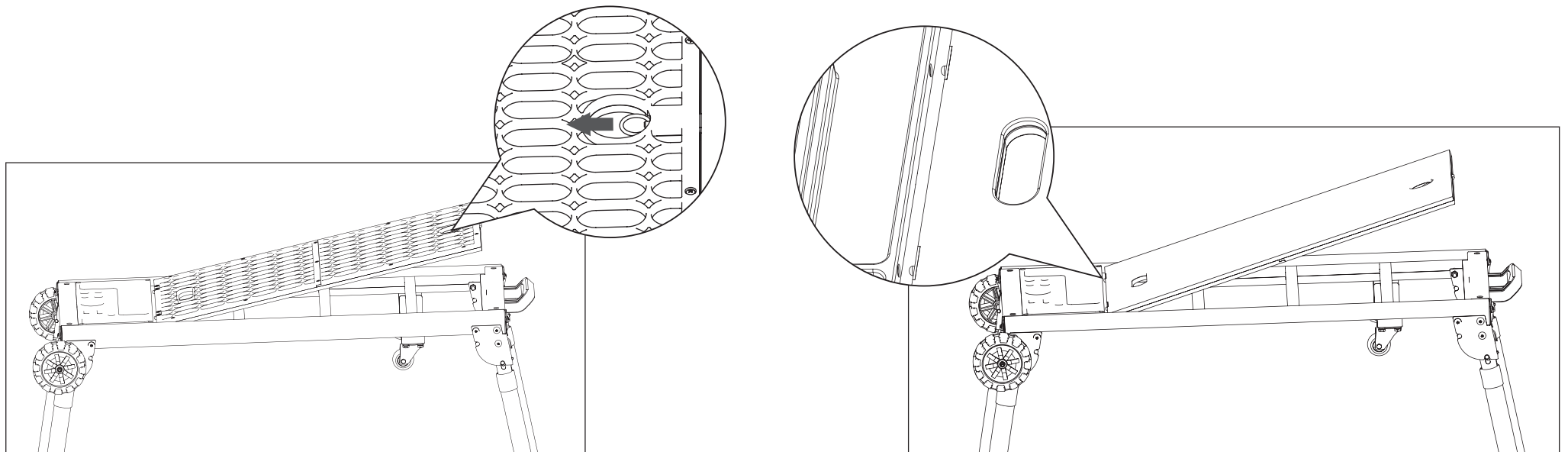

FOLDING THE STAND

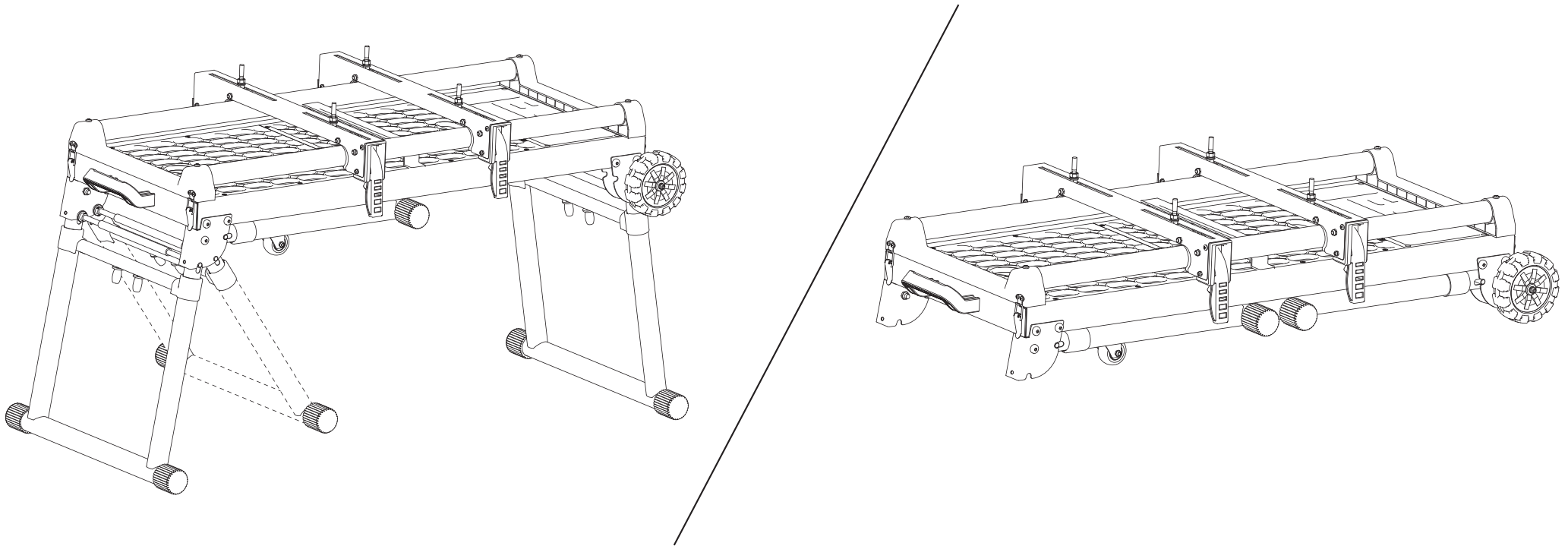

- Press the Locking Lever until the legs are fully folded

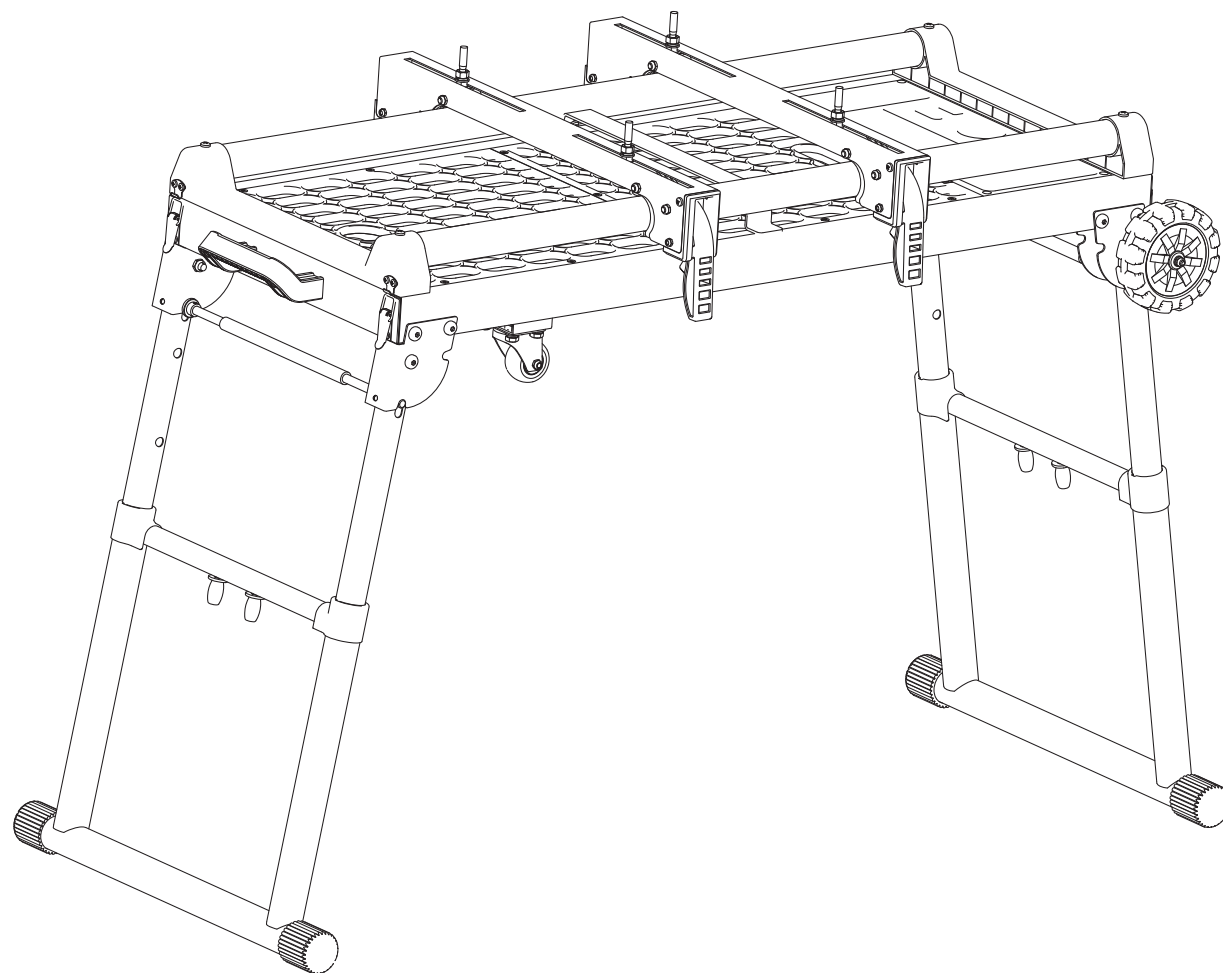

PIÈCES DÉTACHÉES

Assurez-vous que toutes les pièces sont présentes. Si des pièces sont manquantes, ne procédez pas à l'assemblage.

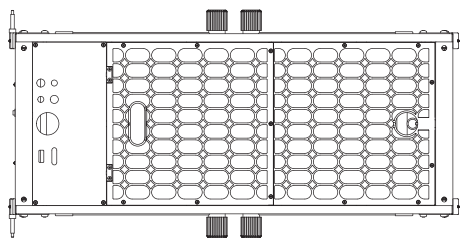

A

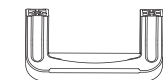

B



C



D



E



F



G



H



I



J



K



L

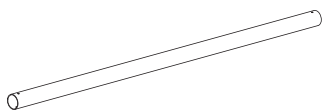

M

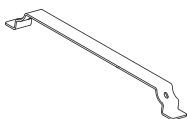

N

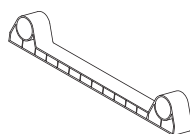

O

Pièce	Description	Qté
A.	Stand	x1
B.	Poignée	x1
C.	Ecrou M6	x4
D.	M6x35	x2
E.	Roue de 5 pouces	x2
F.	Rondelle ϕ 6	x2
G.	Rondelle ϕ 8	x8
H.	Rondelle élastique M8	x8
I.	M8x16	x8
J.	Support d'Outil	x2
K.	Vis	x6
L.	Roue pivotante	x2
M.	Tube supérieur	x2
N.	Support central	x1
O.	Base en plastique	x2

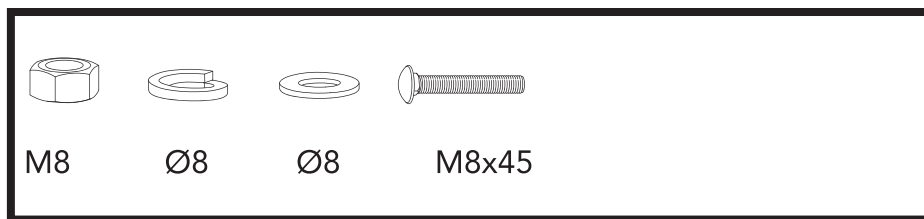
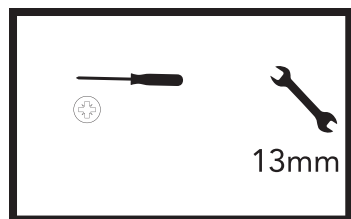

ASSEMBLAGE AVERTISSEMENT Faites preuve de prudence. Il existe un risque de pincement ou de serrage des doigts.

Les pièces nécessaires pour réaliser cette étape de montage.

I x8

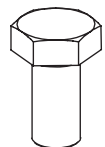

G x8

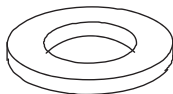

H x8



L x2



- Posez la surface supérieure du stand (A) sur le sol.
- Appuyez sur le levier de verrouillage du pied et soulevez le pied jusqu'à ce que le levier s'enclenche en place.
- Utilisez le boulon M8x16 (I) et la rondelle ϕ 8 (G) pour assembler les roues pivotantes (L).
- Soulevez le stand

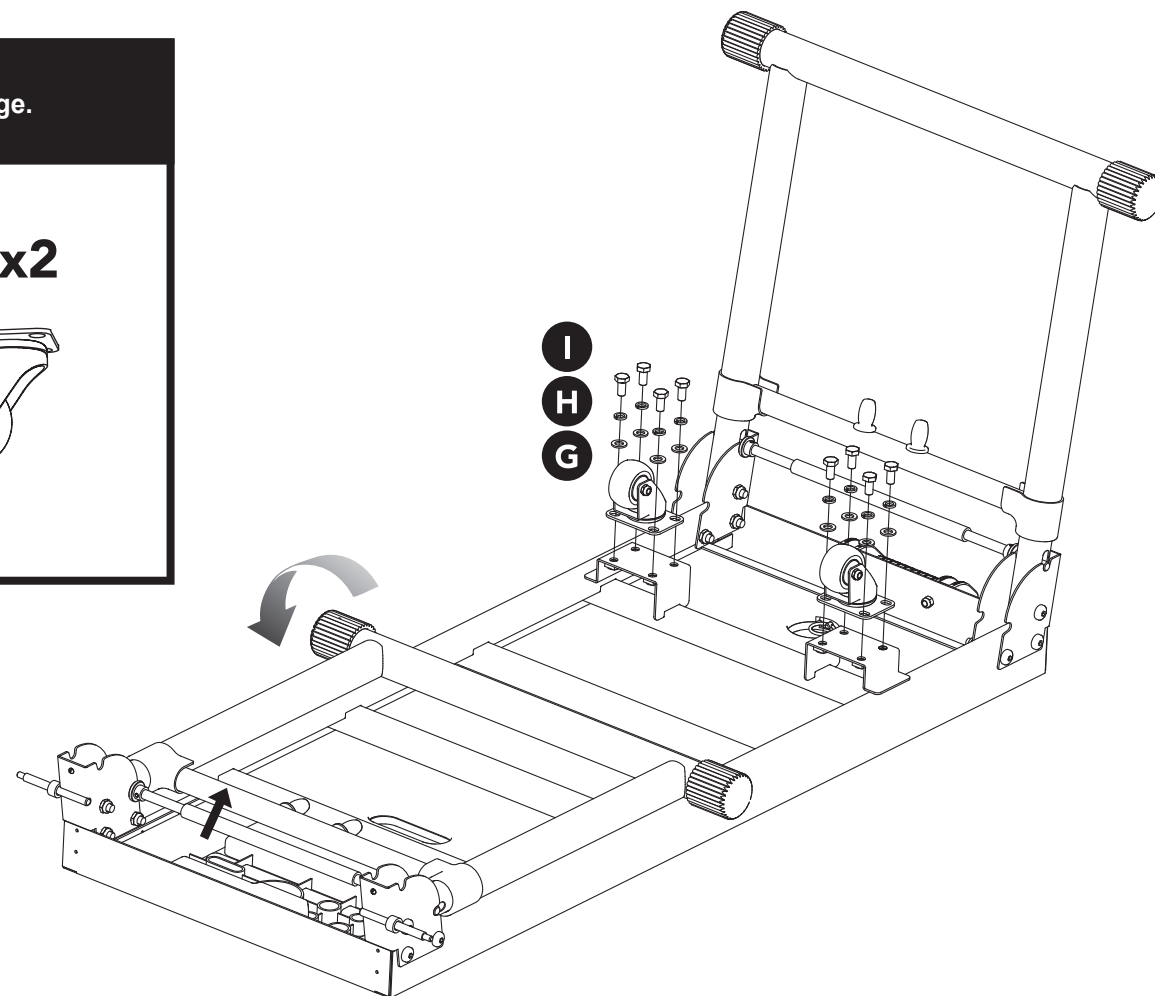

ASSEMBLAGE

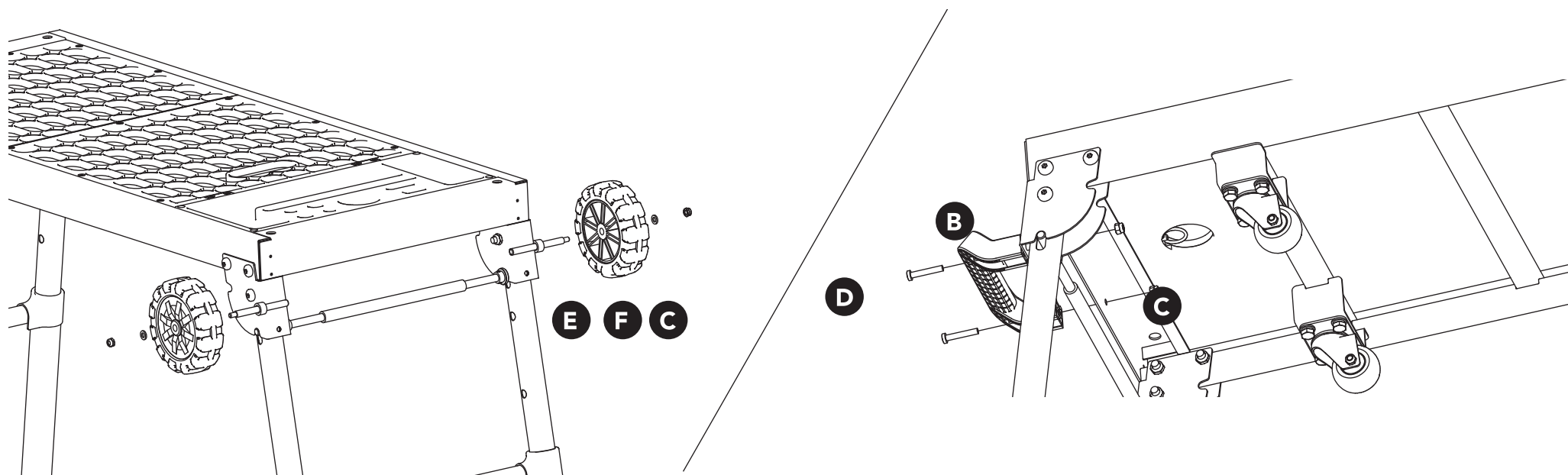

Les pièces nécessaires pour réaliser cette étape de montage.

F x2

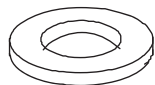

E x2



C x4

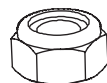

D x2

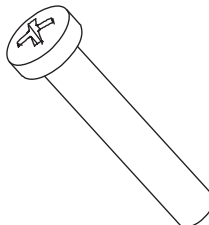

B x1

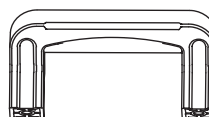

- Utilisez l'écrou M6 (C) et la rondelle ϕ 6 (F) pour assembler la roue 5" (E) à l'axe.
- Utilisez le boulon M6x35 (D) et l'écrou M6 (C) pour assembler la poignée (B).

ASSEMBLAGE

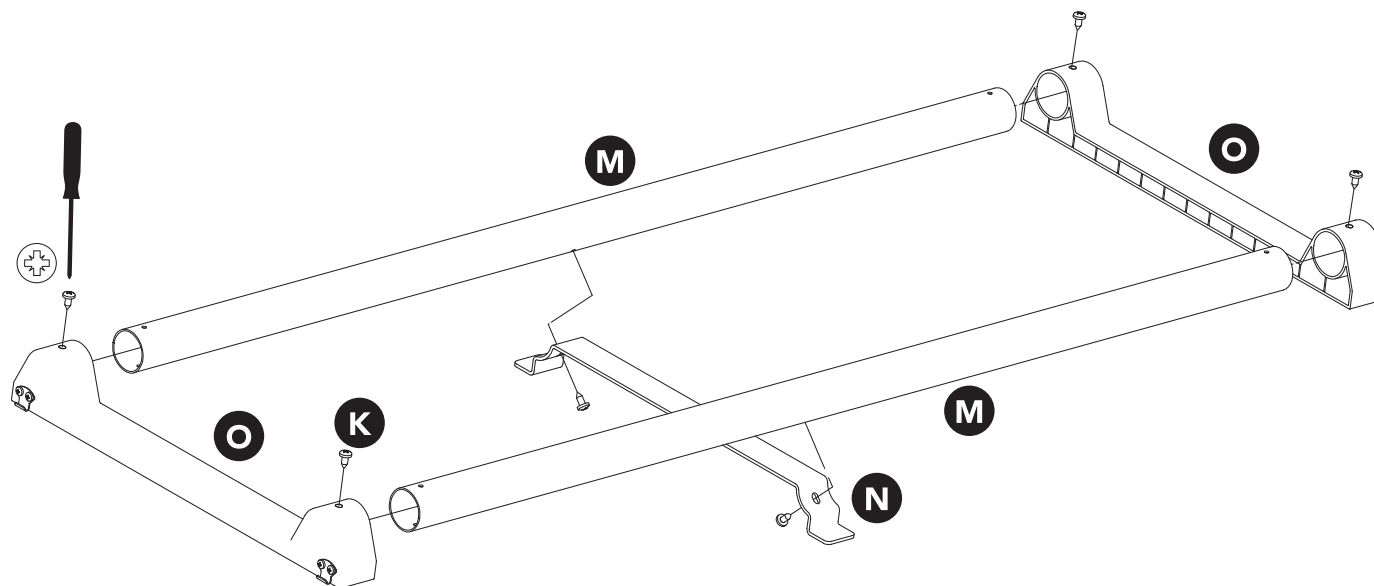

Les pièces nécessaires pour réaliser cette étape de montage.

M x2

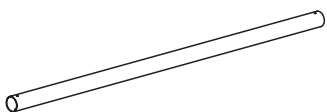

O x2

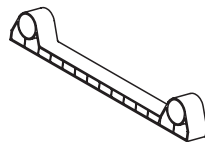

N x1

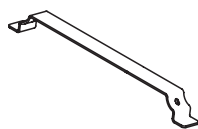

K x6

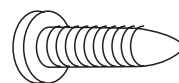

- Insérez le tube supérieur (M) dans la base en plastique (O) et fixez-le avec les vis (K).
- Fixez le support central (N) au tube supérieur (M) avec les vis (K)

ASSEMBLAGE

- Placez le plan de travail assemblé sur le stand et fixez-le à l'aide des 4 loquets de verrouillage.

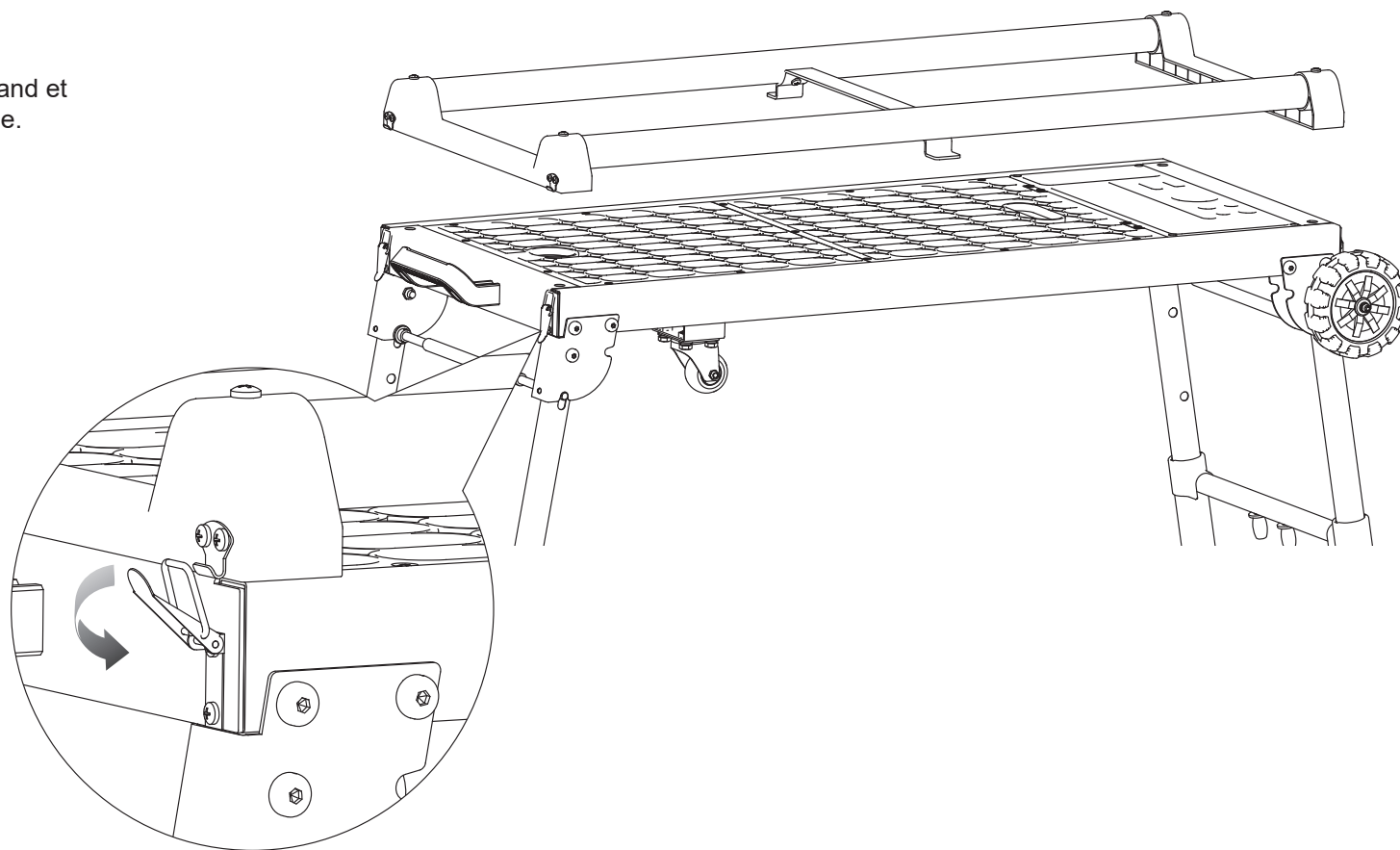

ASSEMBLAGE RÉGLAGE DE LA HAUTEUR

- Serrez le bouton à l'intérieur et tirez la table de haut en bas pour l'ajuster à la hauteur désirée.
- Assurez-vous que la goupille de verrouillage se bloque fermement à la nouvelle hauteur.

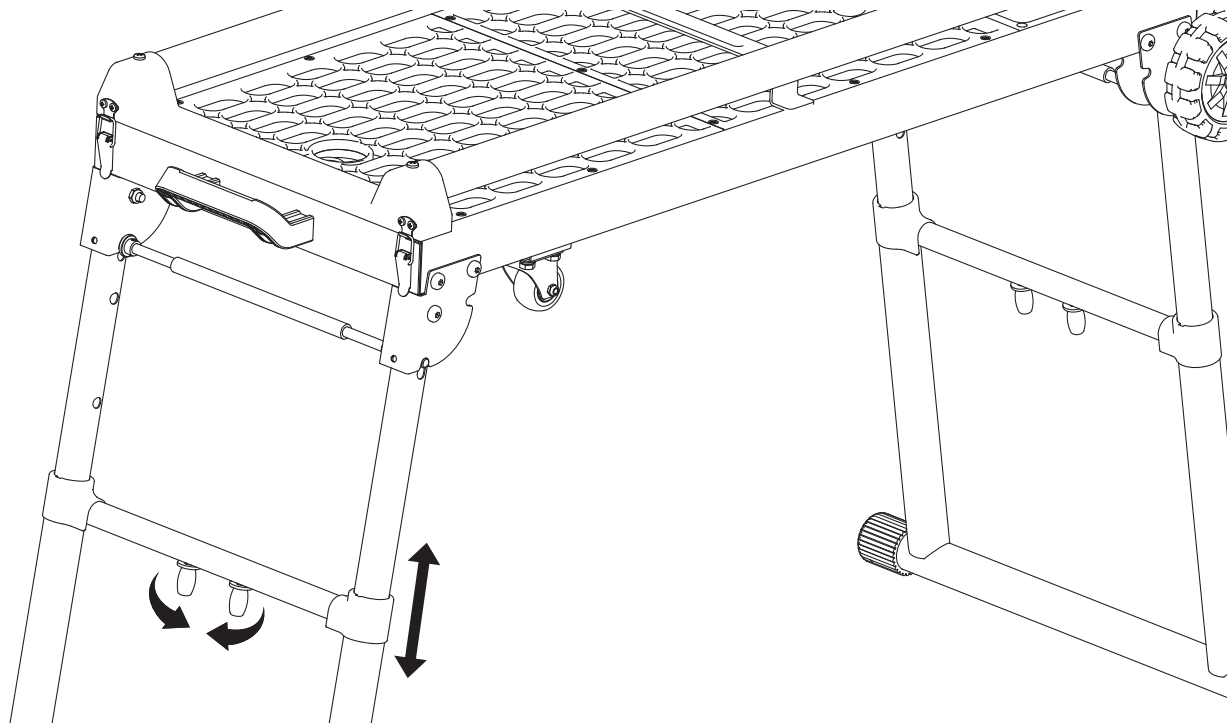

MONTAGE D'UNE SCIE À ONGLET SUR LE STAND

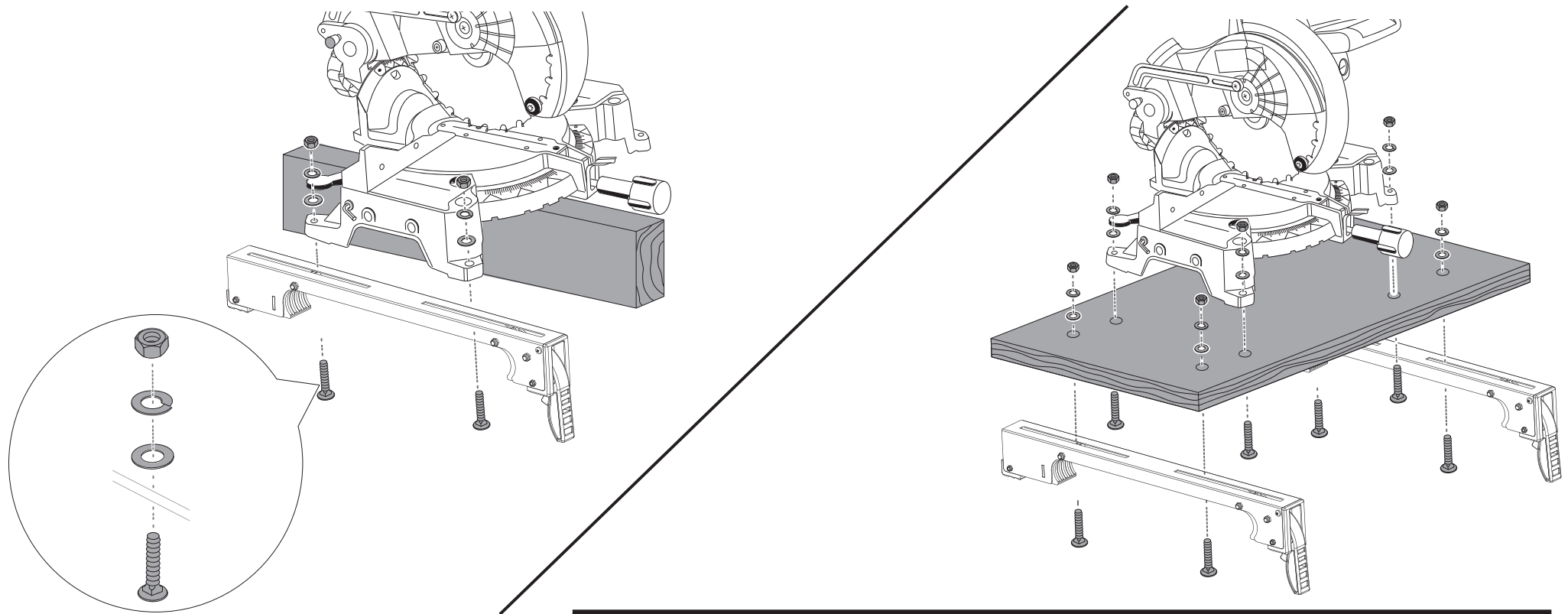

- Débranchez la scie et le bras de la scie en position basse.
- Placez un support d'outil sous la scie, en alignant les trous de montage de la base de la scie à onglet avec la fente du haut du support d'outil.
- Fixez le boulon de chariot à travers le support d'outil et le trou de montage de la scie.
- Fixez-le en place à l'aide d'une rondelle plate. Bloquez la rondelle et l'écrou, puis répétez l'opération à l'autre extrémité du support d'outil

Les pièces nécessaires pour réaliser cette étape de montage. (non fournies)

x8

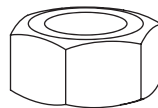

x8



x8



x8

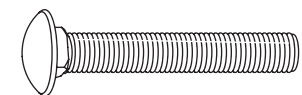

MONTAGE D'UNE SCIE À ONGLET SUR LE STAND

- Utilisez les poignées situées à l'arrière des supports d'outils pour faciliter l'installation ou le retrait de l'ensemble scie et support.
- Soulevez l'ensemble scie et support d'outil, en laissant l'ensemble s'incliner légèrement vers votre corps.
- Accrochez le bord avant de l'ensemble de support d'outil sur le rail avant du stand.
- Abaissez l'ensemble de support d'outil pour permettre au bord arrière du support d'outil de se placer complètement sur le rail arrière.

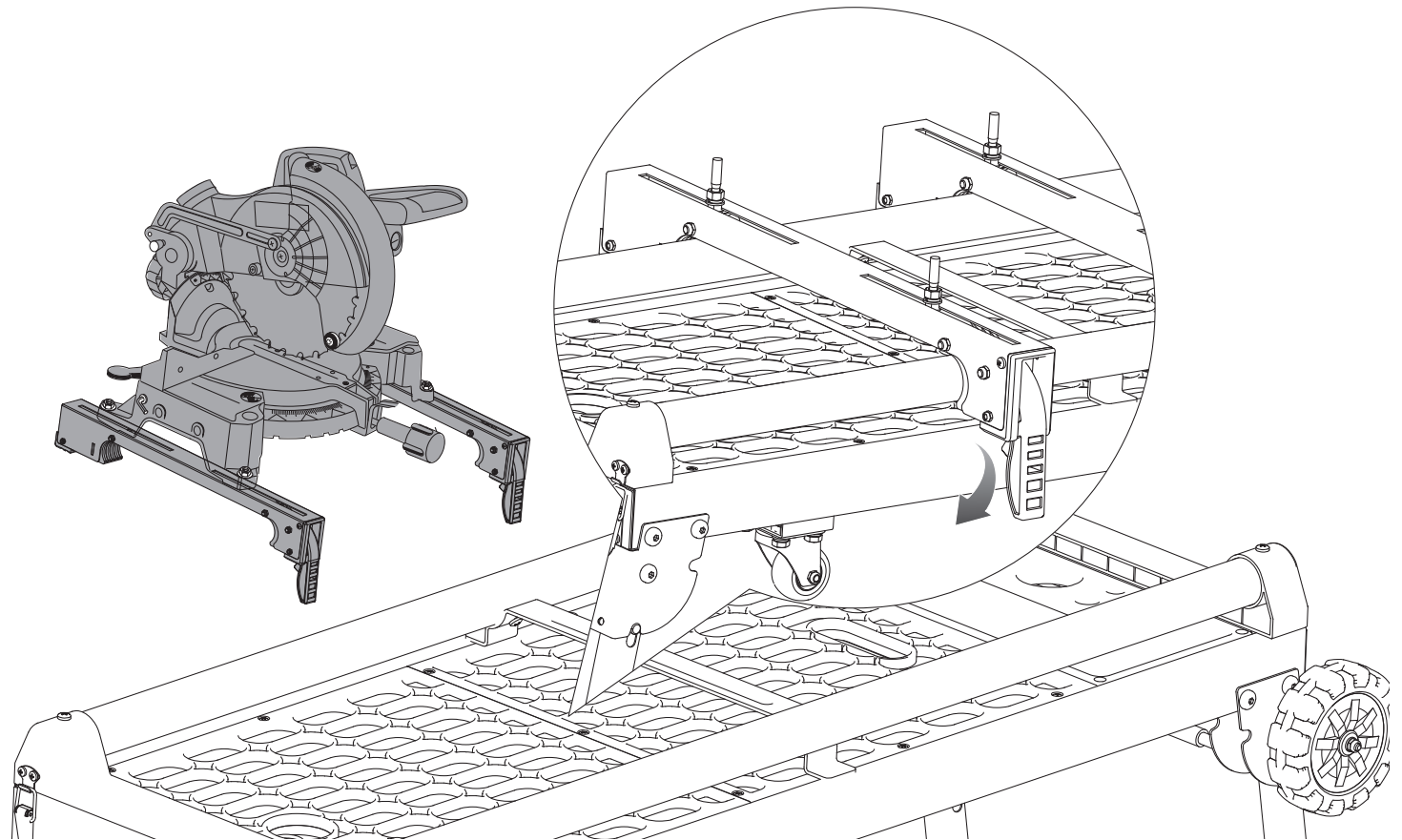

DÉMONTAGE DE LA SCIE À ONGLET DU STAND

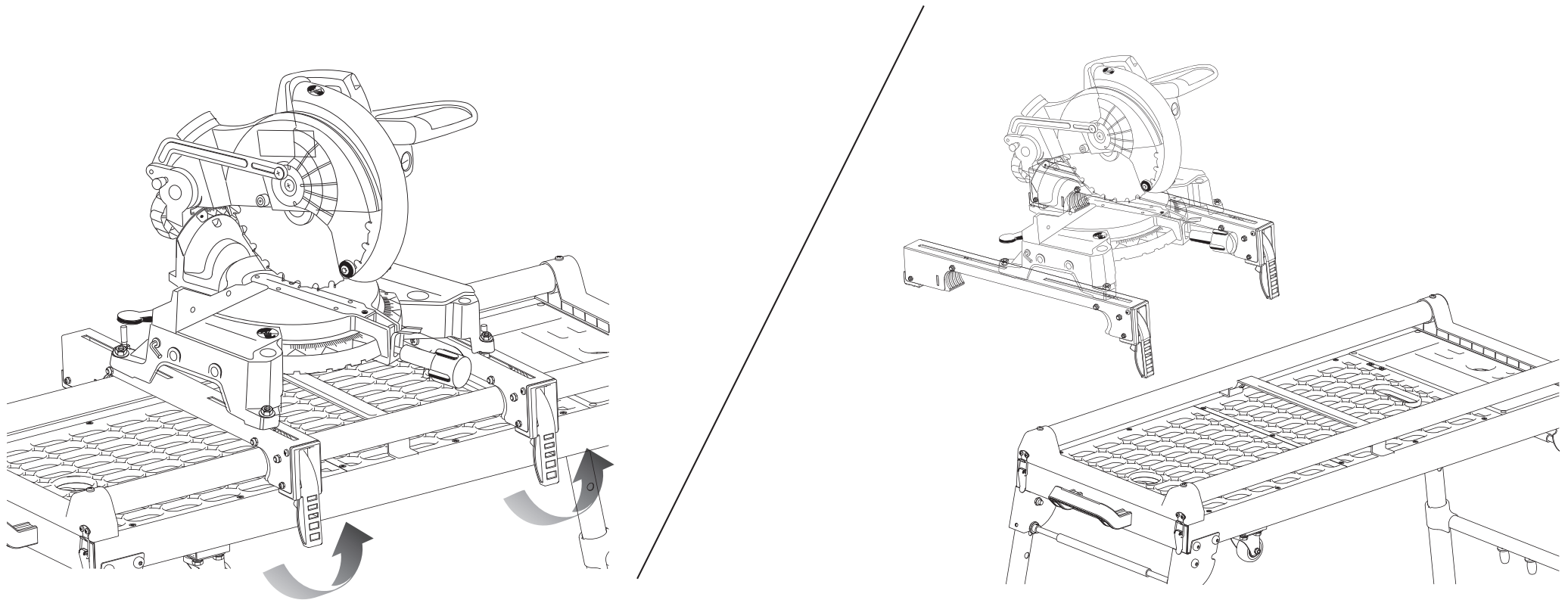

- Soulevez les leviers de verrouillage (J) pour déverrouiller la scie et les supports d'outils.
- Saisissez les poignées de chaque côté de l'ensemble et soulevez-le pour l'éloigner du rail arrière du stand et le désengager.
- Avec l'ensemble légèrement incliné vers vous, soulevez la partie avant de l'ensemble pour la dégager de l'avant du rail du stand.

ASSEMBLAGE

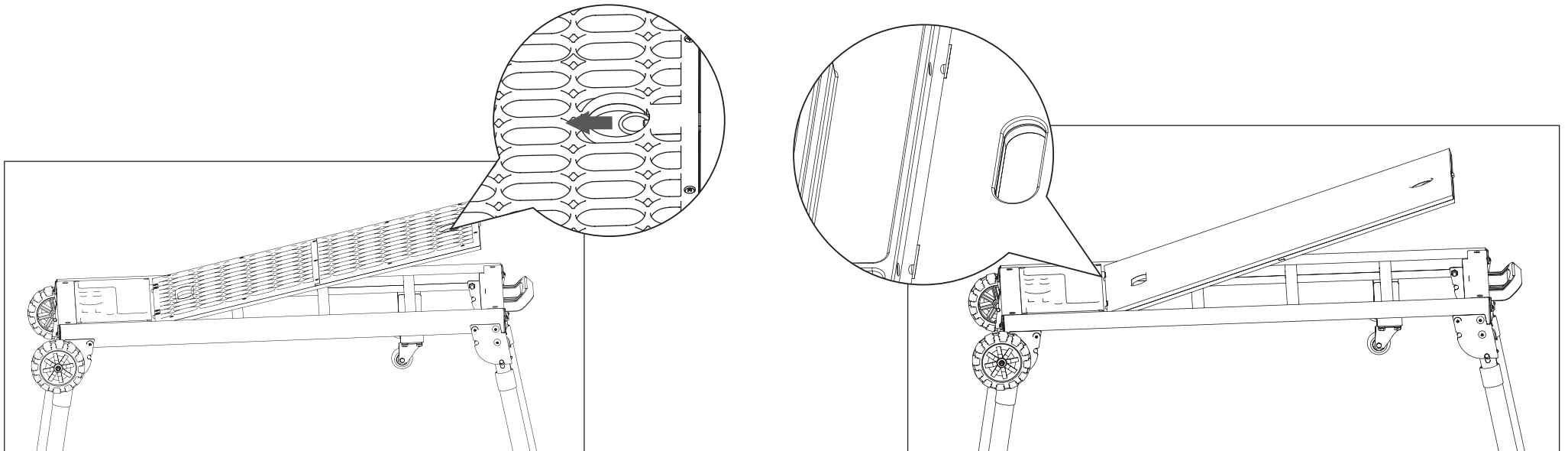

PLIER LE STAND

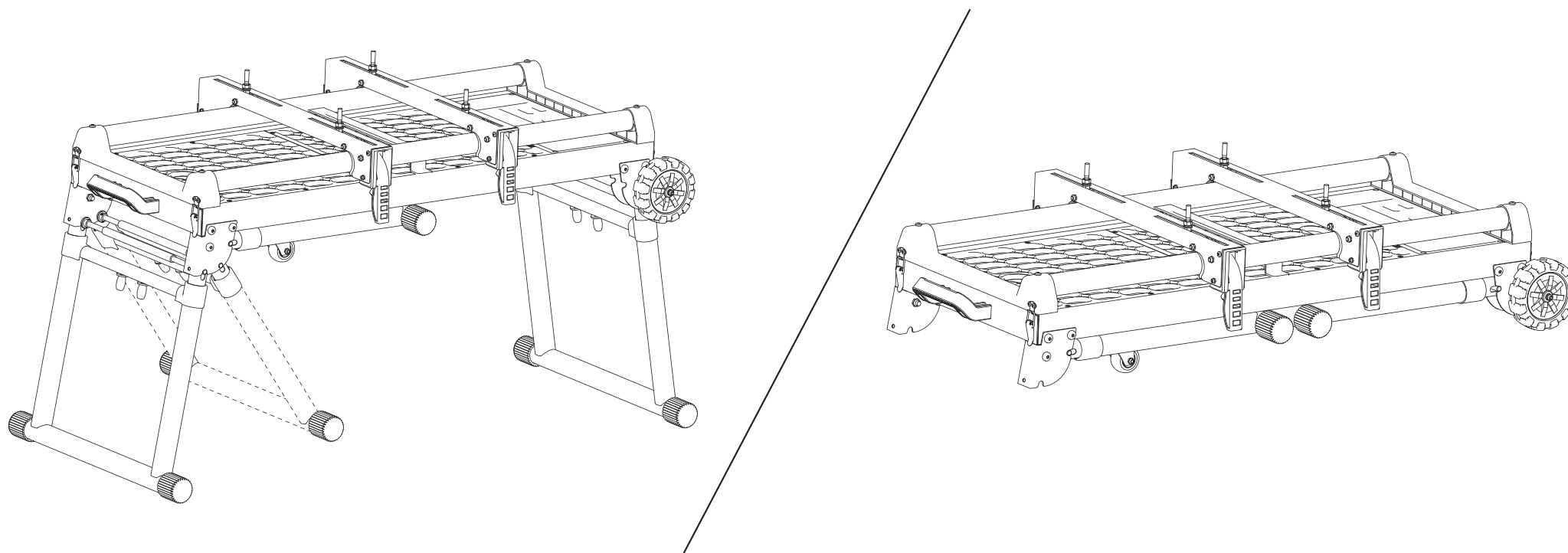

- Appuyez sur le levier de verrouillage jusqu'à ce que les pieds soient entièrement repliés.

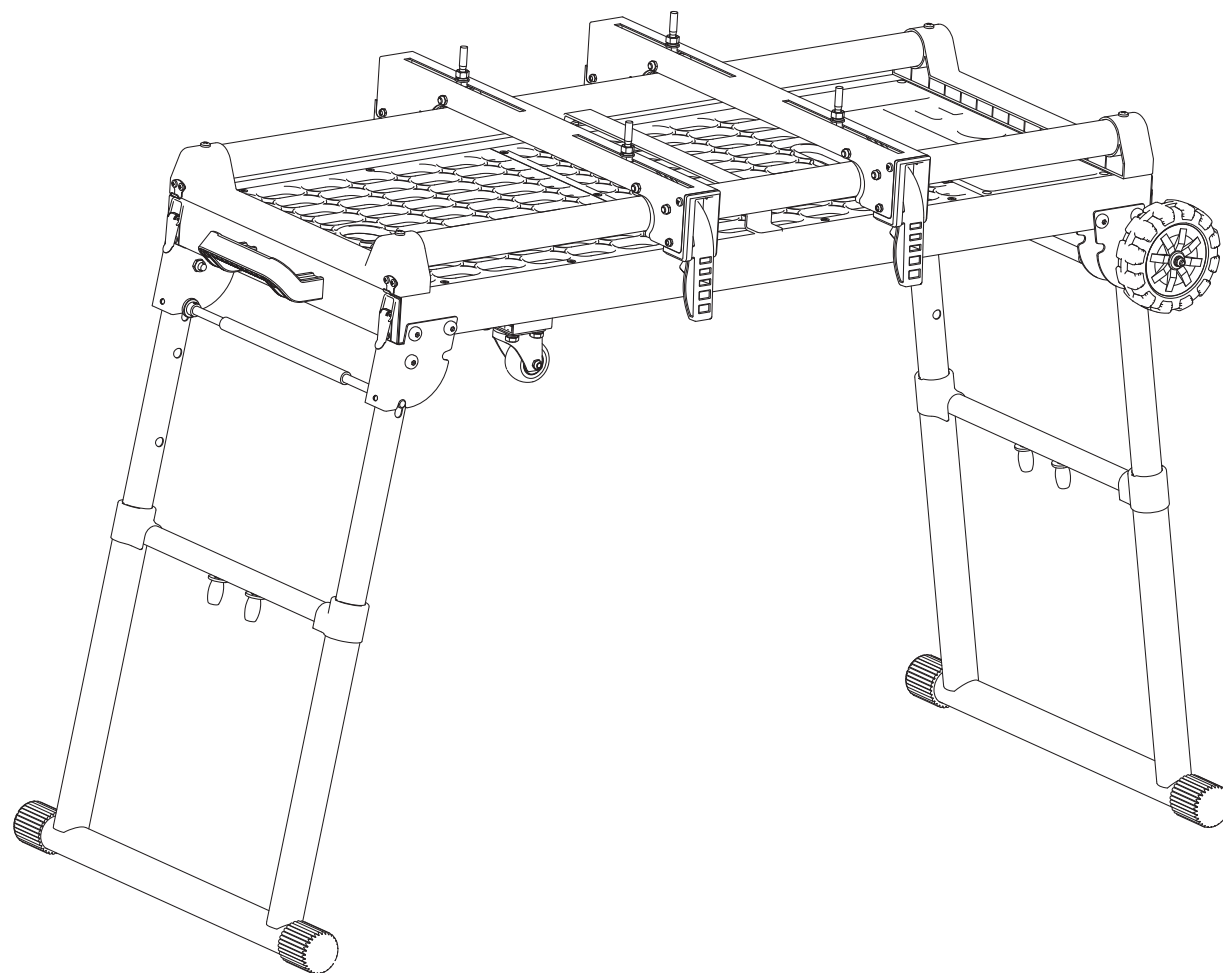

COMPONENTI

Assicurarsi che tutti i componenti siano al completo. Qualora mancassero dei componenti, non procedere con il montaggio.

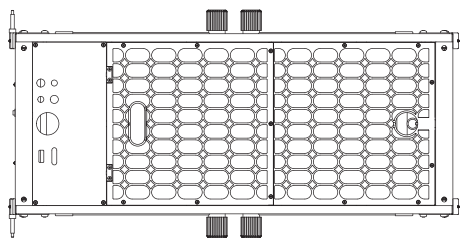

A

B

C

D

E



F



G



H



I



J



K



L

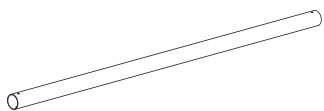

M

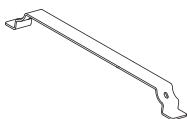

N

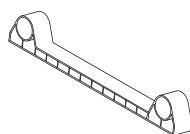

O

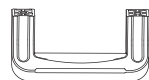

Parte	Descrizione	Qta'
A.	Ripiano	x1
B.	Maniglia	x1
C.	M6 dado	x4
D.	M6x35	x2
E.	5" ruota	x2
F.	φ 6 Rondella	x2
G.	φ 8 Rondella	x8
H.	M8 Rondella elastica	x8
I.	M8x16	x8
J.	Morsetto per attrezzi	x2
K.	Vite	x6
L.	Ruota girevole	x2
M.	Tubo superiore	x2
N.	Supporto centrale	x1
O.	Base in plastica	x2

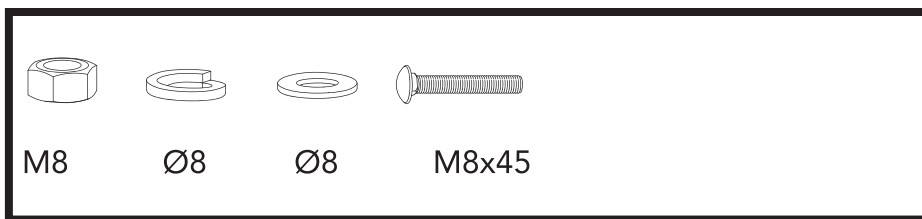
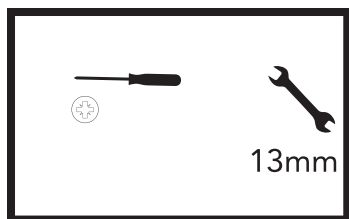

ASSEMBLAGGIO AVVERTENZA Prestare attenzione. Esiste il rischio di pizzicamento / intrappolamento delle dita.

Componenti necessari per completare questa fase di assemblaggio.

I x8

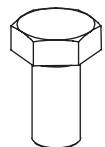

G x8

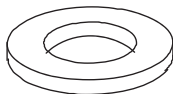

H x8



L x2



- Appoggiare il ripiano superiore del supporto (A) per terra
- Premere la leva di blocco della gamba e sollevarla finché la leva non scatta in posizione
- Utilizzare un bullone M8x16 (I) e una rondella ϕ 8 (G) per assemblare le ruote girevoli (L)
- Sollevare il ripiano

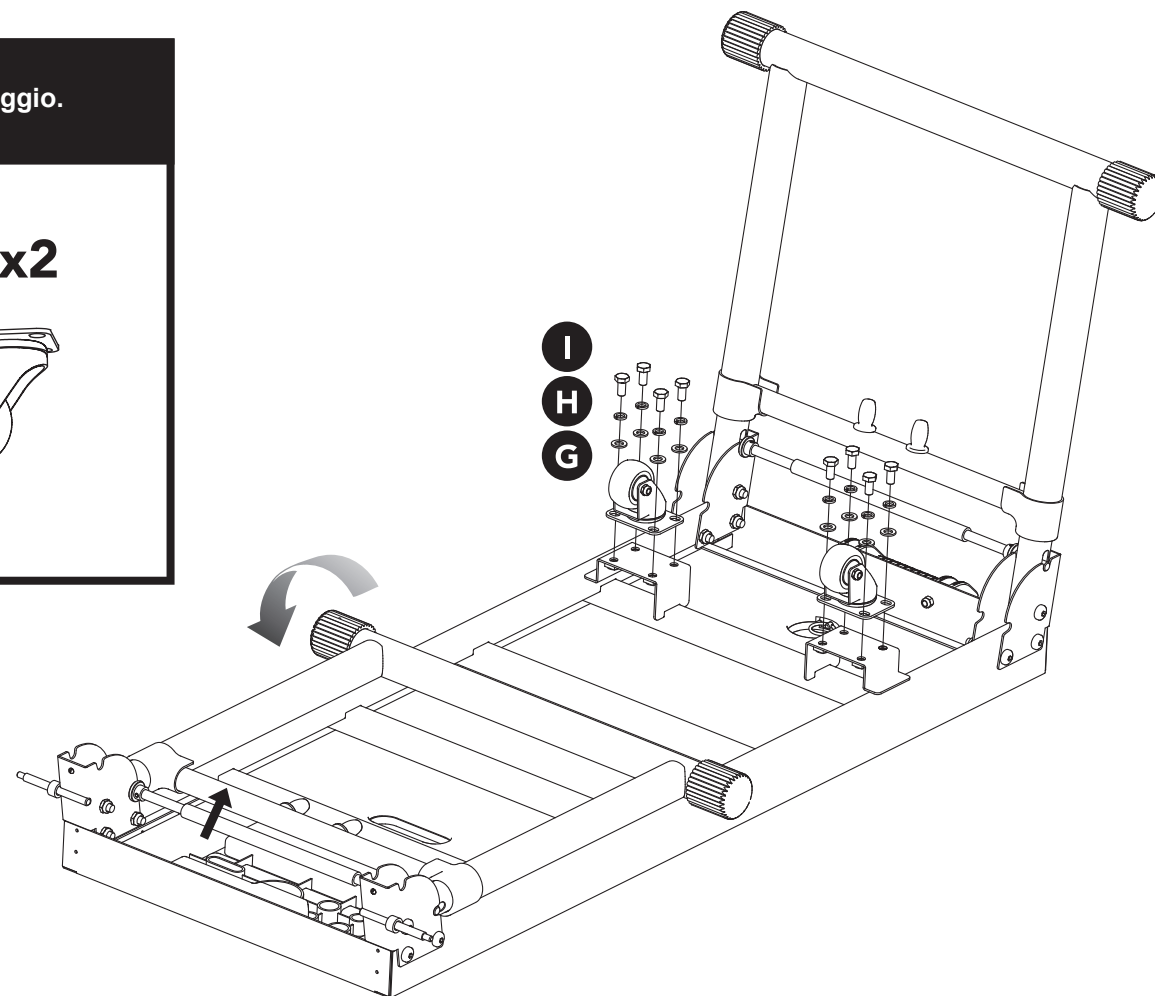

ASSEMBLAGGIO

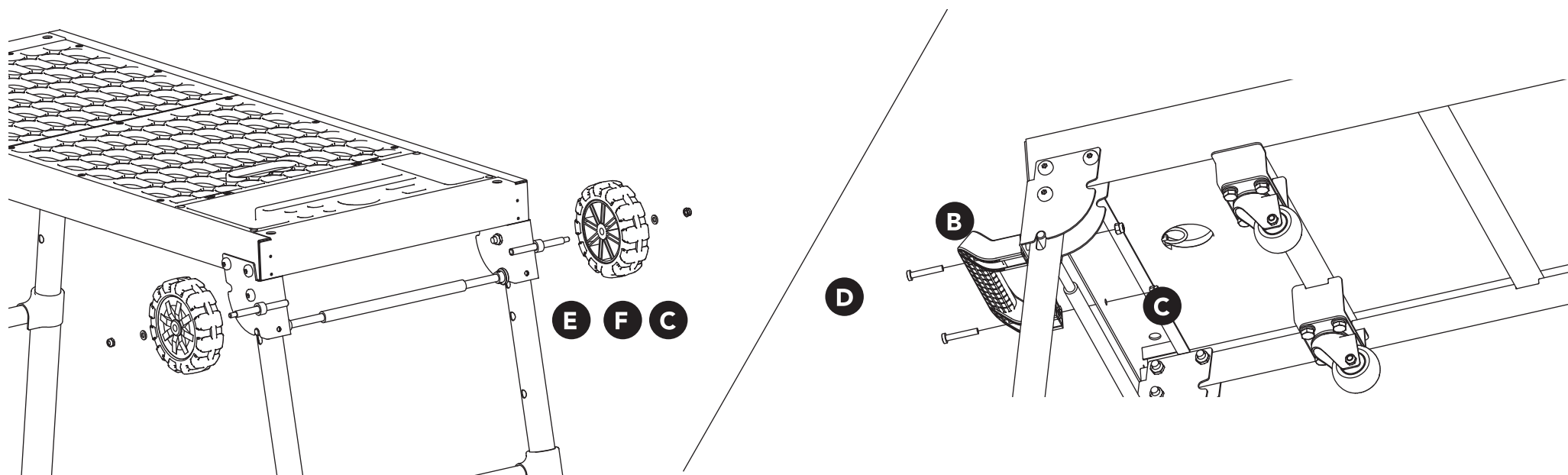

Componenti necessari per completare questa fase del montaggio.

F x2

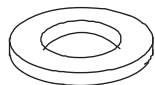

E x2



C x4

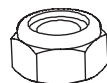

D x2

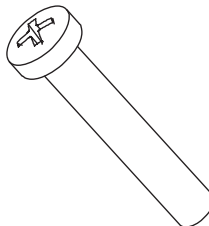

B x1

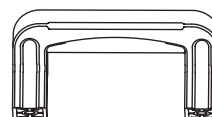

- Utilizzare un dado da M6 (C) e una rondella ϕ 6 (F) per montare la ruota da 5" (E) sull'asse.
- Utilizzare un bullone M6x35 (D) e un dado M6 (C) per montare la maniglia (B).

ASSEMBLAGGIO

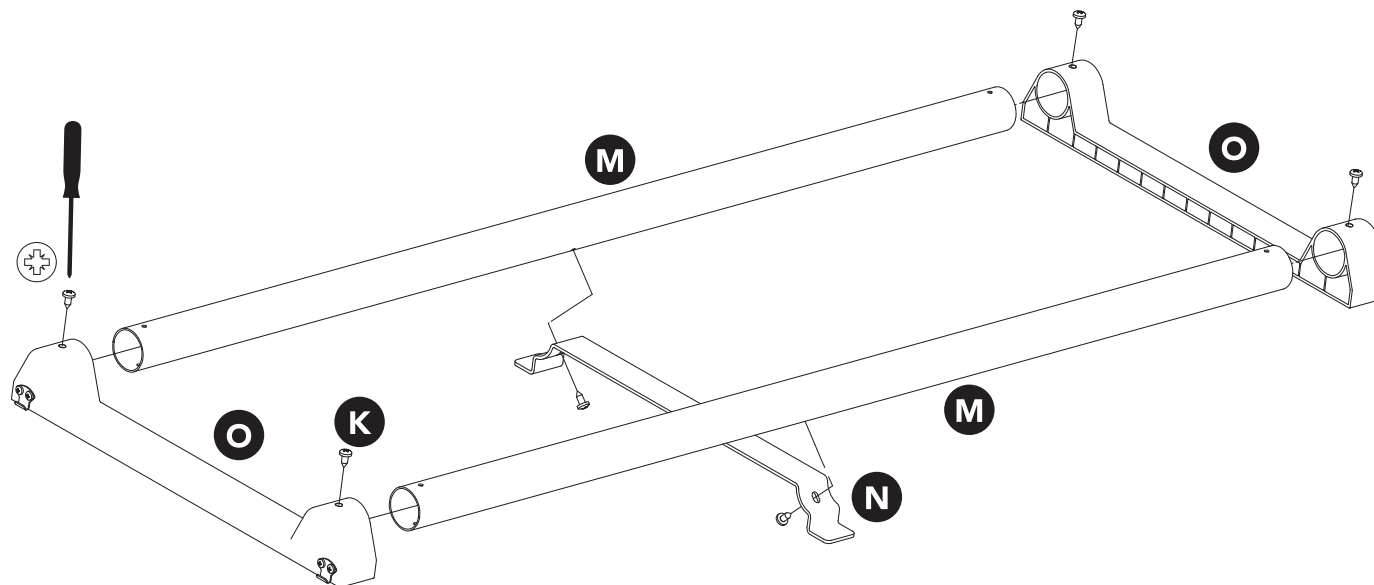

Componenti necessari per completare questa fase del montaggio.

M x2

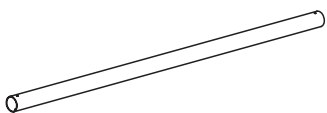

O x2

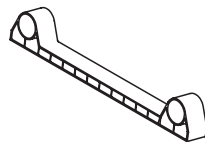

N x1

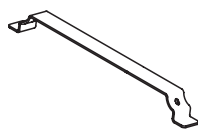

K x6

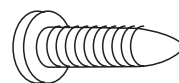

- Inserire il tubo superiore (M) nella base in plastica (O) e fissarlo con le viti (K)
- Fissare il supporto centrale (N) al tubo superiore (M) con le viti (K)

ASSEMBLAGGIO

- Posizionare il ripiano assemblato sul supporto e fissarlo con i 4 morsetti di blocco.

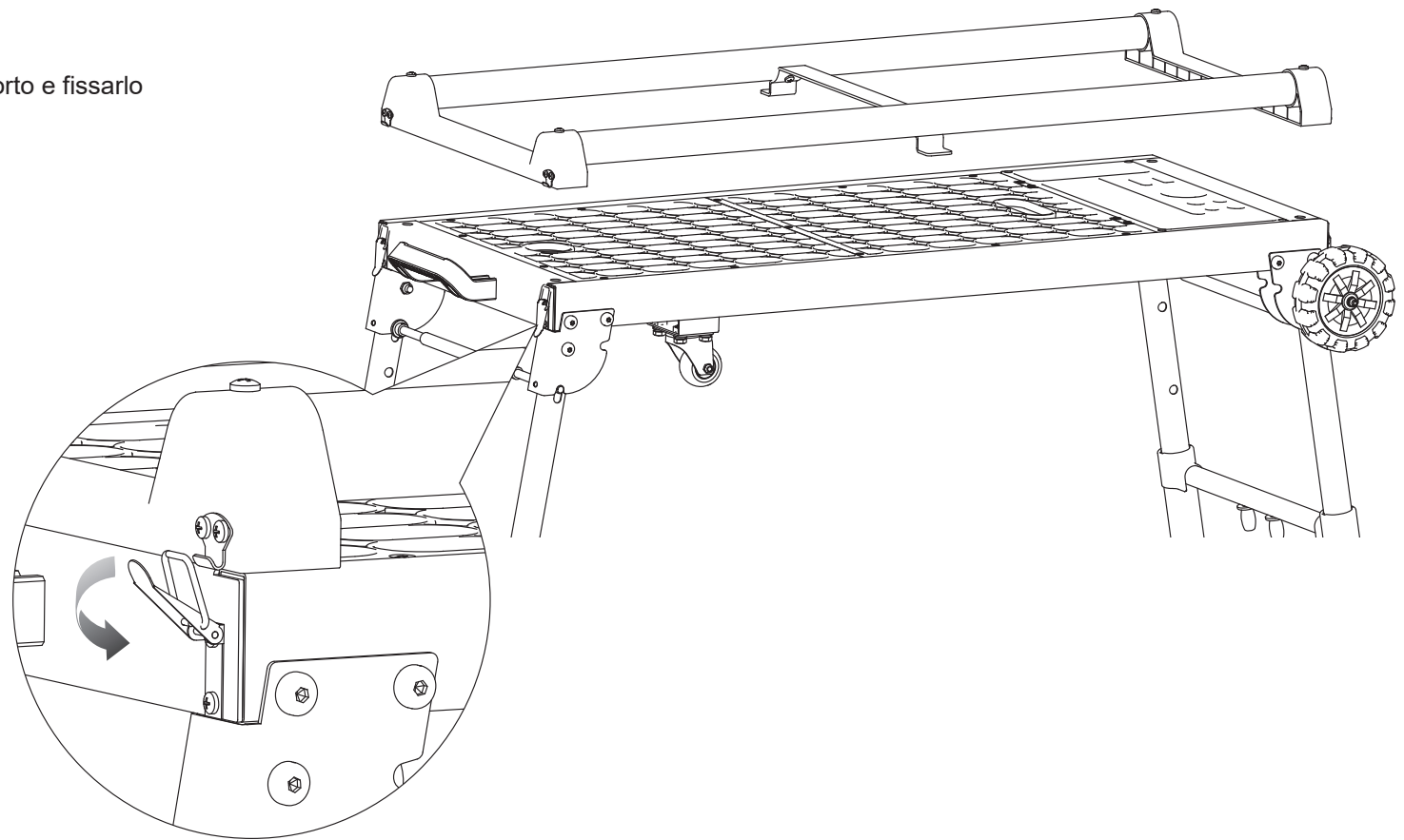

ASSEMBLAGGIO REGOLARE L'ALTEZZA

- Stringere il pulsante all'interno e tirare il ripiano in alto e in basso per regolare l'altezza desiderata.
- Verificare che il perno di bloccaggio si blocchi saldamente una volta raggiunta nuova altezza.

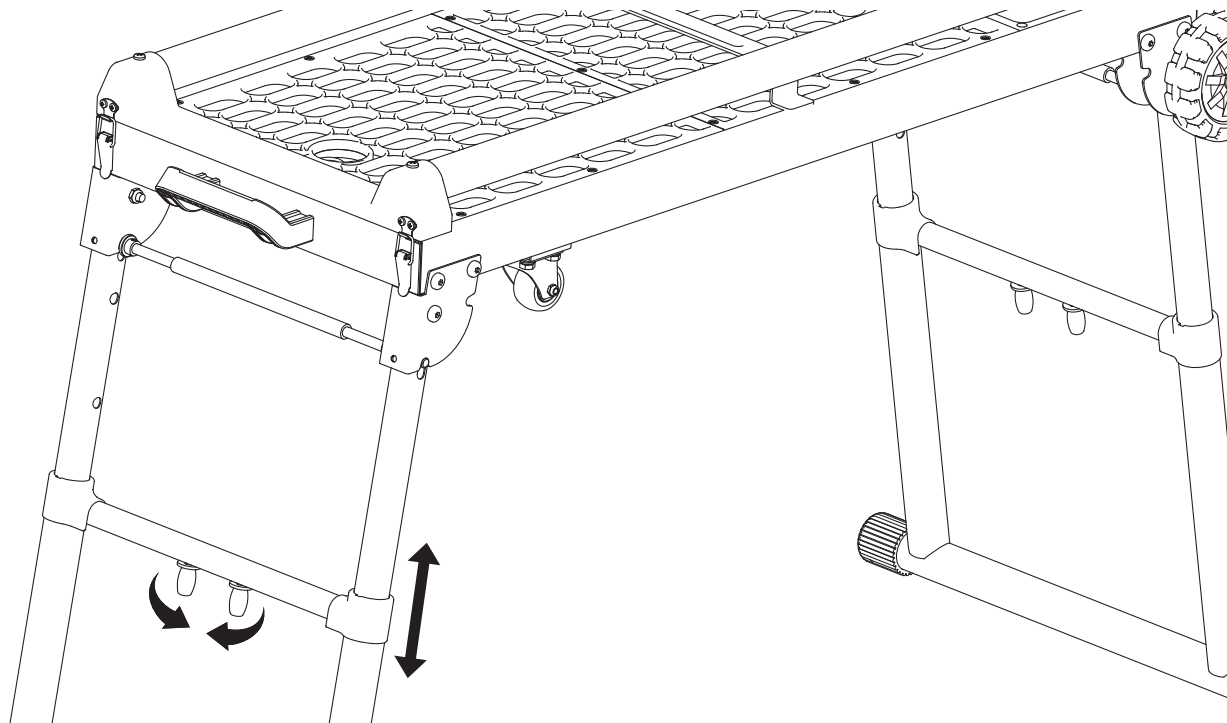

MONTARE UNA TRONCATRICE AL RIPIANO

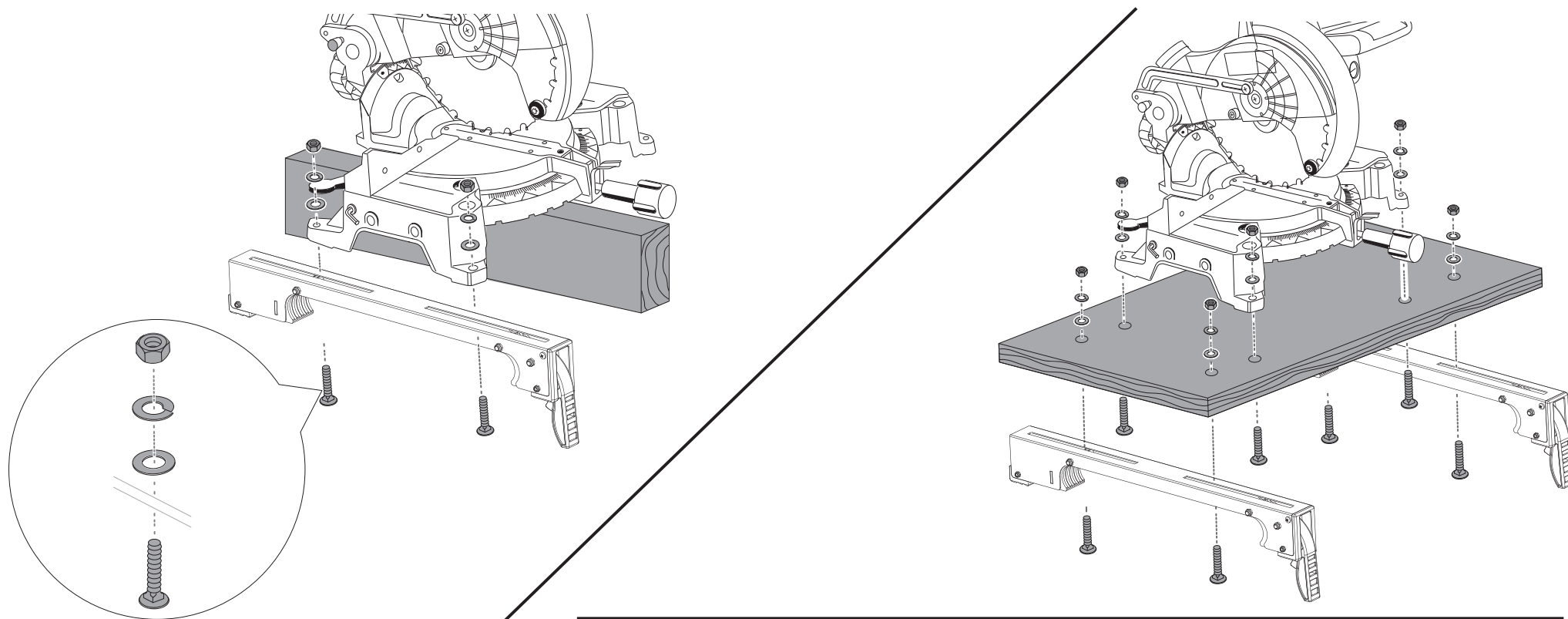

- Scollegare la sega e il braccio della sega rivolti verso il basso.
- Posizionare un supporto sotto la sega, allineando i fori di montaggio sulla base della troncatrice con la fessura nella parte superiore del supporto.
- Fissare il bullone di supporto ruotando verso l'alto, sia attraverso il supporto che attraverso il foro di montaggio della sega.
- Fissare in posizione utilizzando una rondella piatta. Bloccare la rondella e il dado, ripetere l'operazione sull'altra estremità del supporto.

Componenti necessari per completare questa fase del montaggio. (non inclusi)

x8

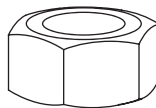

x8



x8



x8

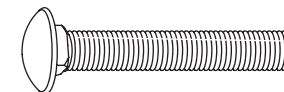

MONTARE UNA TRONCATRICE AL RIPIANO

- Utilizzare le maniglie che si trovano sul retro del supporto per facilitare l'installazione o la rimozione del gruppo sega piu' staffa
- Sollevare la sega e il gruppo di montaggio dell'attrezzo, consentendogli di inclinarsi leggermente verso la struttura
- Agganciare il bordo anteriore del gruppo di montaggio dell'attrezzo alla guida anteriore del supporto.
- Abbassare il gruppo di montaggio dell'attrezzo per consentire al bordo posteriore del supporto di posizionarsi completamente sulla guida posteriore.

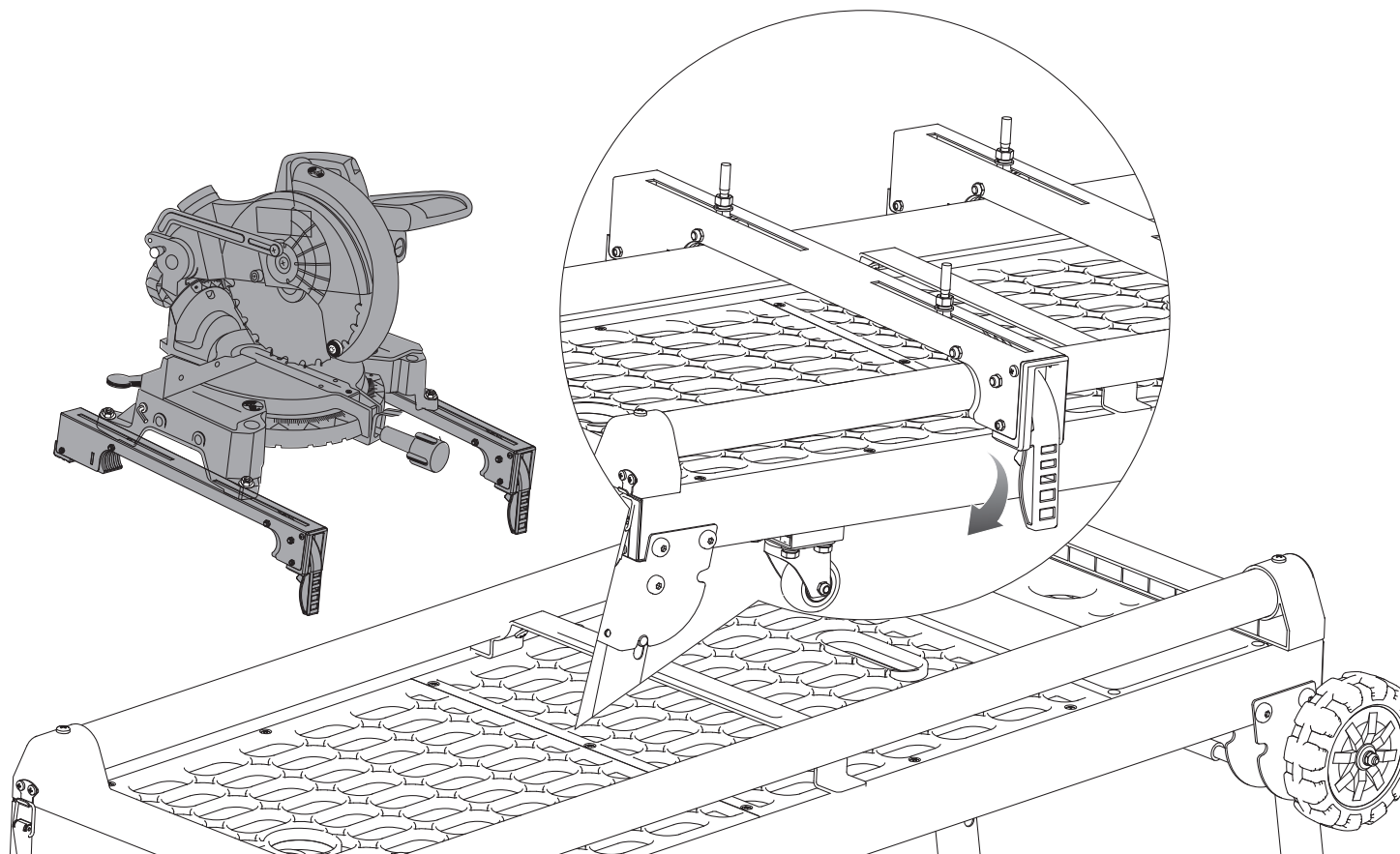

SMONTARE UNA TRONCATRICE DAL RIPIANO

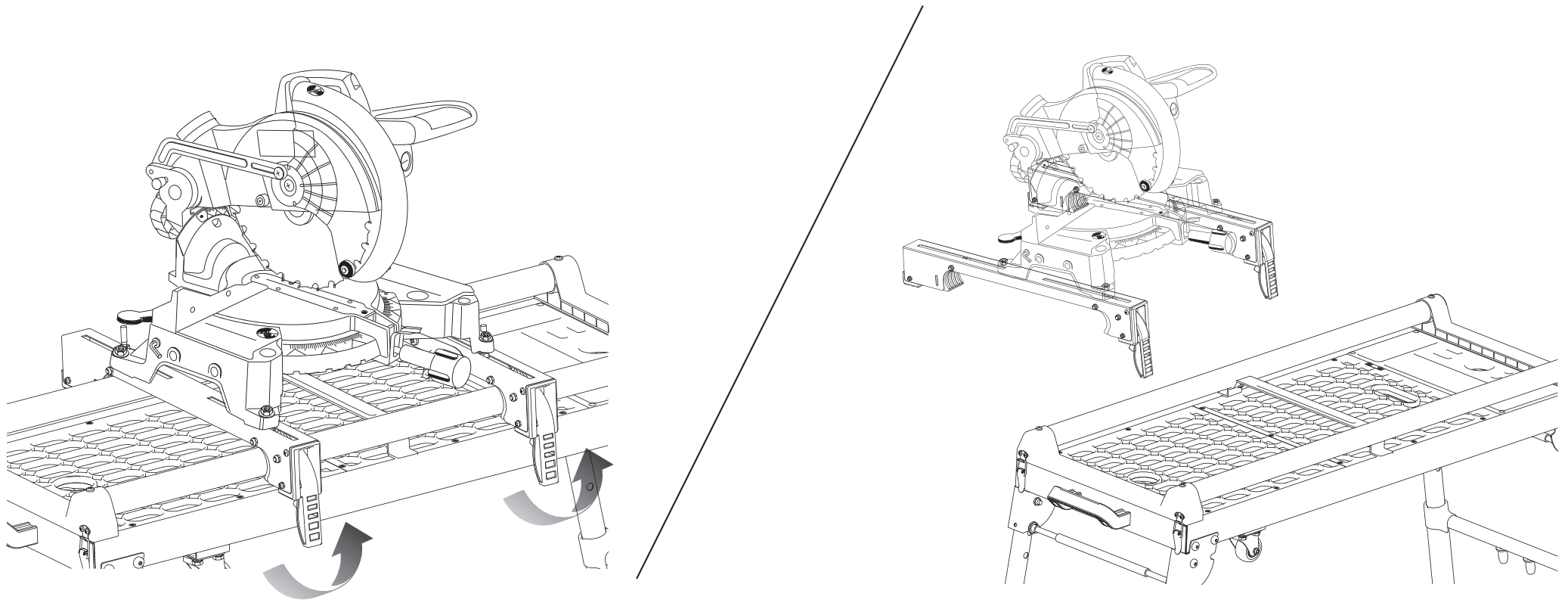

- Sollevare le leve di bloccaggio (J) per rimuovere il blocco della sega e del supporto.
- Afferrare le maniglie su entrambi i lati e sollevarle dalla guida posteriore del supporto per sganciarle.
- Con il gruppo leggermente inclinato verso il proprio corpo, sollevare la parte anteriore del gruppo per sganciarlo dalla parte anteriore della guida.

ASSEMBLAGGIO

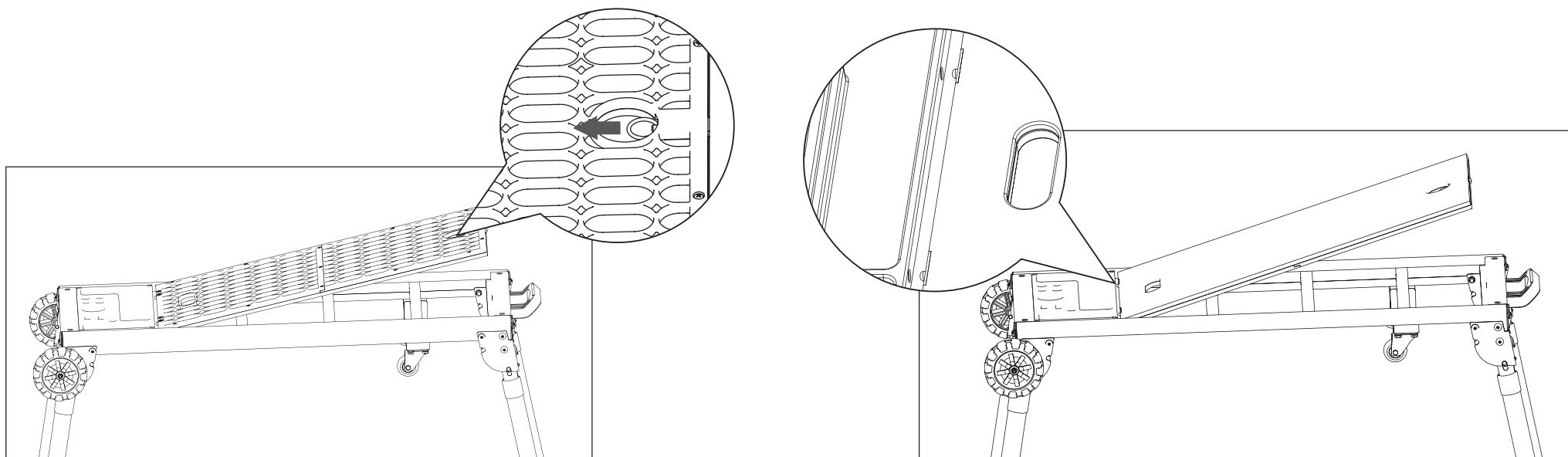

RIPIEGARE IL RIPIANO

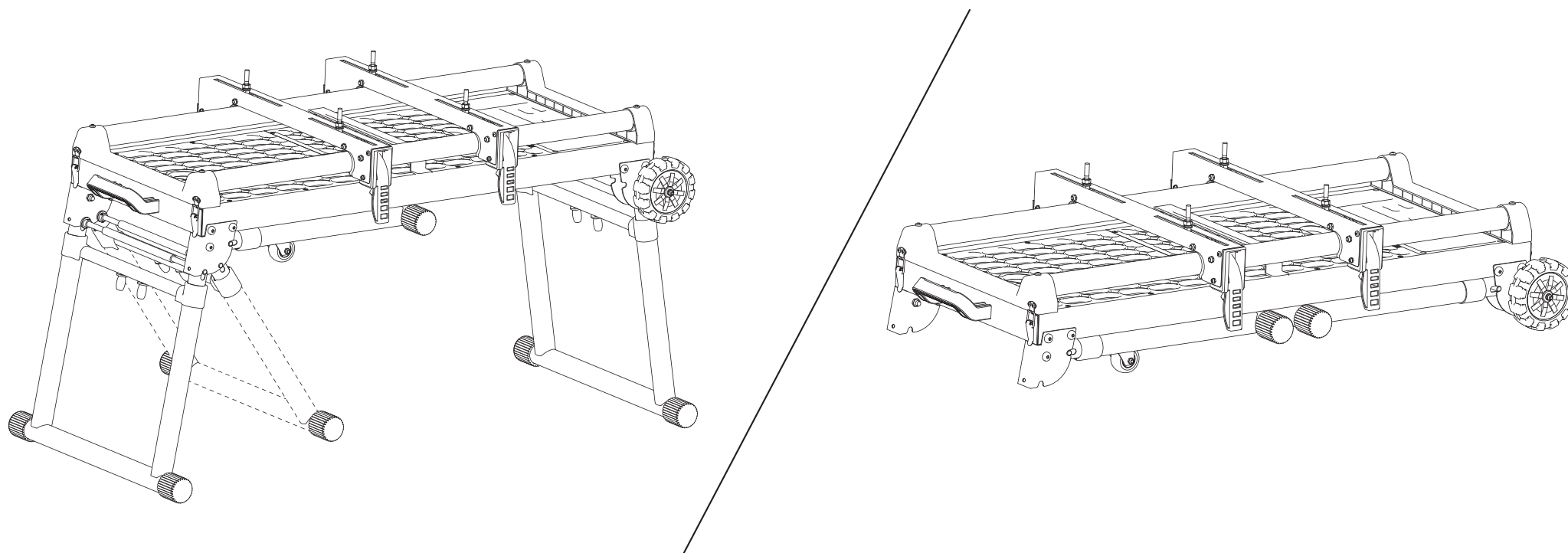

- Premere la leva di bloccaggio fino a quando le gambe non sono completamente ripiegate su se stesse.



001-877-644-9366
customerservice@aosom.com



001-855-537-6088
customerservice@aosom.ca



0044-800-240-4004
enquiries@mhstar.co.uk



0049-(0)40-88307530
service@aosom.de



0033-1-84166106
contact@aosom.fr



0034-931294512
atencioncliente@aosom.es



0039-0249471447
clienti@aosom.it