

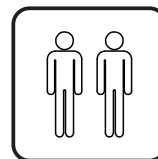

INcea056_US_CA_FR

B71-052 B71-052V80

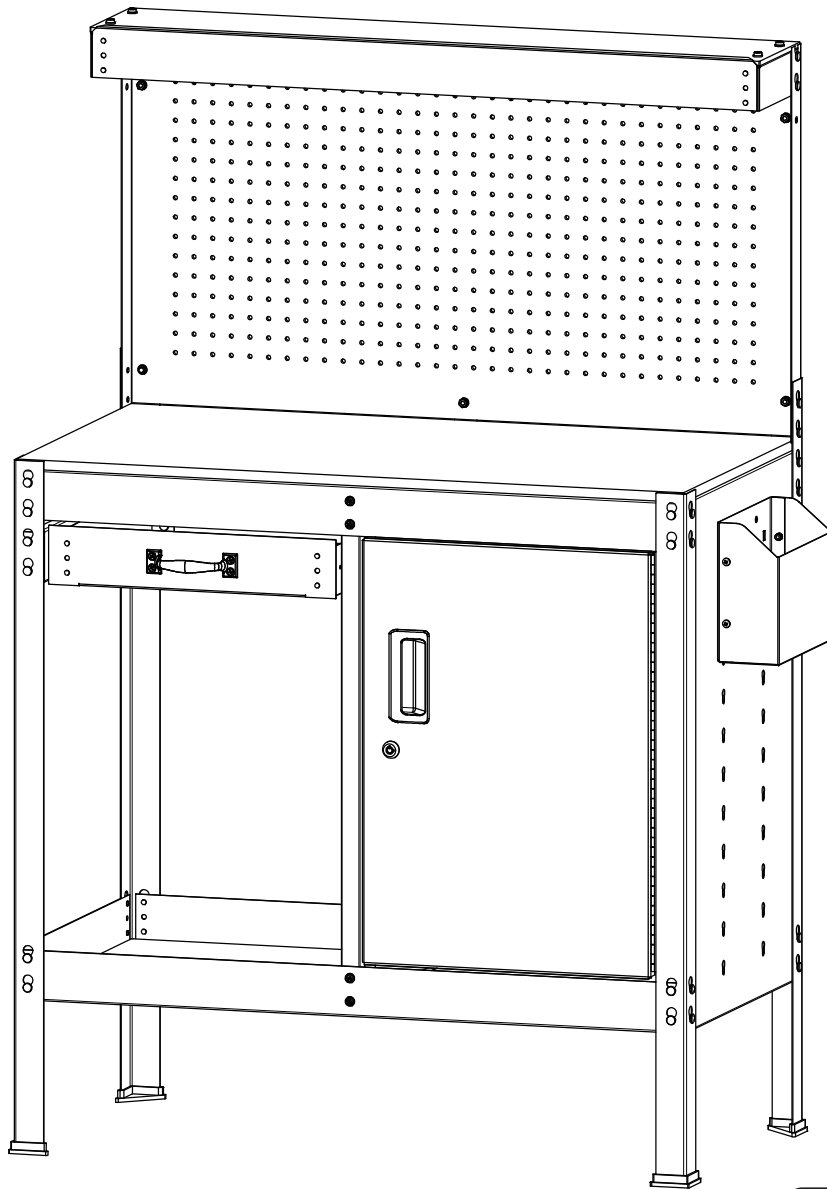

IMPORTANT, RETAIN FOR FUTURE REFERENCE: READ CAREFULLY

ASSEMBLY & INSTRUCTION MANUAL

WARNING:

Read this material before using this product. Failure to do so can result in serious injury.
SAVE THIS MANUAL.

Do not exceed listed loading rate, evenly distributed. Sudden load movement may briefly create excess load causing product failure.

Loading capacity of workbench: 100Kgs

Loading capacity of top shelf: 20Kgs

Loading rate of drawer: 10Kgs

Loading rate of bottom shelf: 20Kgs

AVERTISSEMENT:

Lisez ce document avant d'utiliser ce produit. Le non-respect de cette consigne peut entraîner des blessures graves. CONSERVEZ CE MANUEL.

Ne pas dépasser le taux de charge indiqué, réparti uniformément. Un mouvement soudain de la charge peut brièvement occasionner un excès de charge et provoquer une défaillance du produit.

Capacité de charge de la table de travail: 100 kg.

Capacité de charge de l'étagère supérieure: 20 kg

Taux de charge du tiroir: 10 kg

Capacité de charge de l'étagère inférieure: 20Kg

Part No.	Components	Quantity
1L		1
1R		1
2L		1
2R		1
3F		1
3R		1
4		4
4B		1
5L		1
5R		1
6		2
7		1
8L		1
8R		1
9F		1
9R		1
10L		1
10R		1

Part No.	Components	Quantity
11		1
12	Top Shelf (thickness 6mm) <i>Étagère supérieure (épaisseur 6mm)</i>	1
13	Bench Top (thickness 12mm) <i>Table de travail (épaisseur 12mm)</i>	1
14	Drawer Bottom (thickness 4.5mm) <i>Fond de tiroir (épaisseur 4,5 mm)</i>	1
15	Bottom Shelf (thickness 6mm) <i>Étagère inférieure (épaisseur 6mm)</i>	1
16		4
17		21
18		42
19		21
20		10
21		10
22		10
23		1
24		1
25		1
26	Cabinet Back Panel (thickness 4mm) <i>Panel arrière de l'armoire (épaisseur 4mm)</i>	1
27		1
28		1
29		1

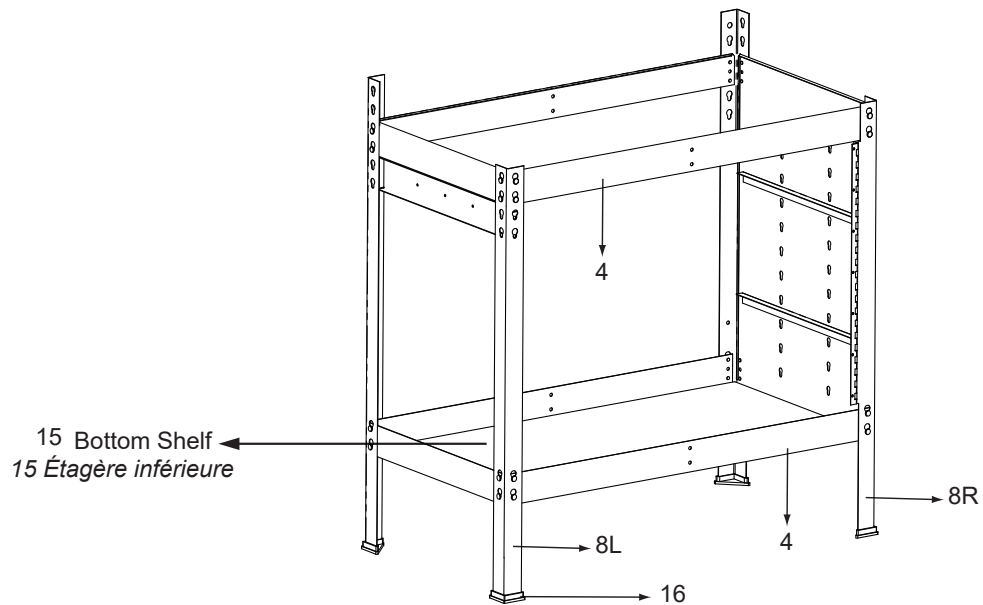
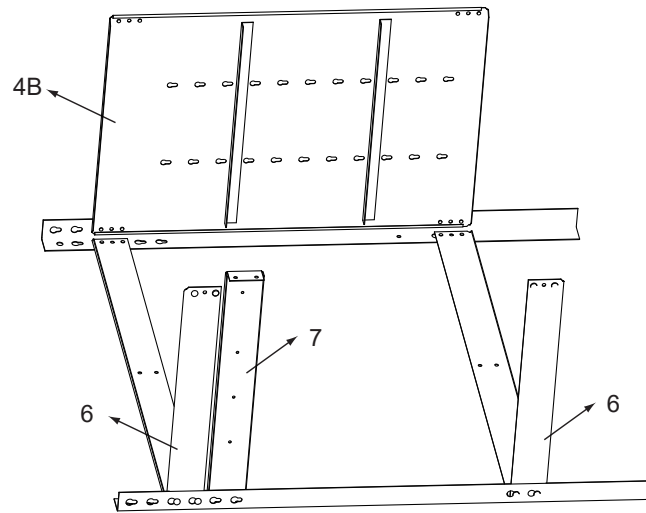
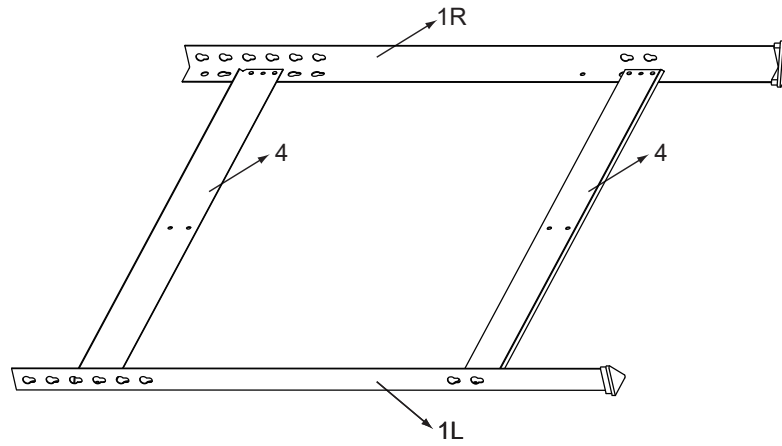

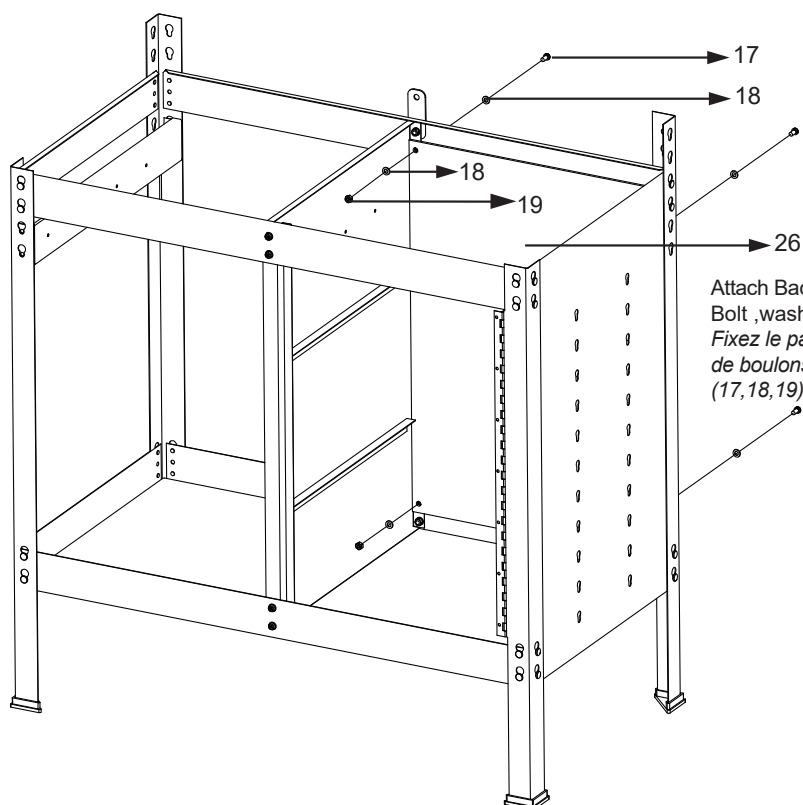
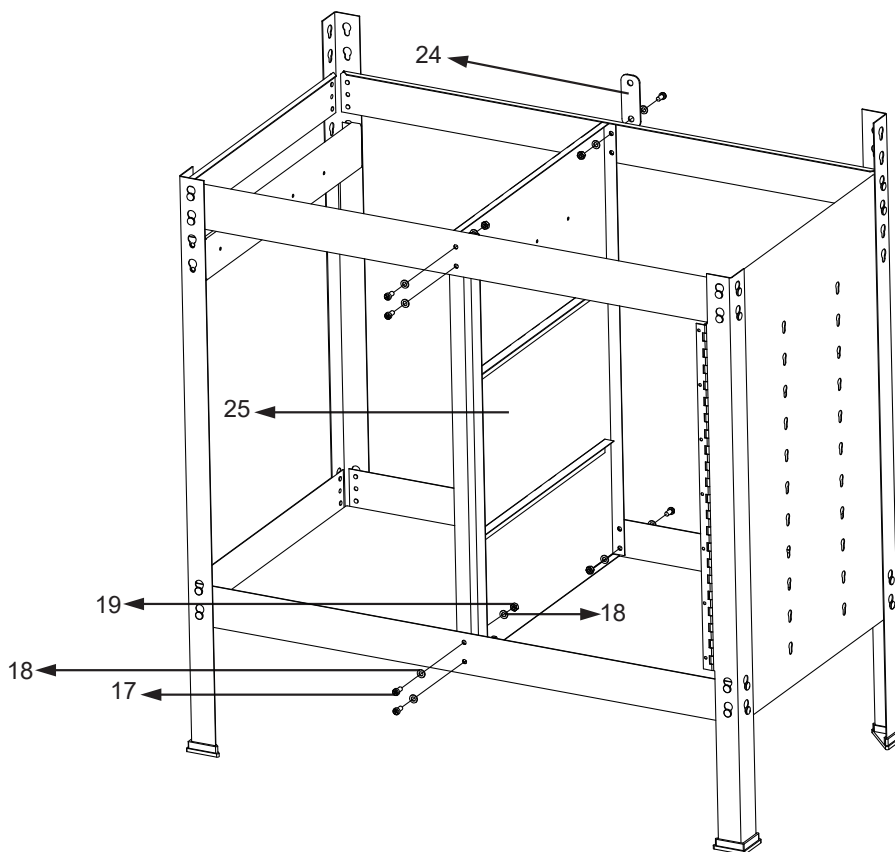

Attach Back Panel To Cabinet Using
Bolt ,washer And Nuts.(17,18,19)
*Fixez le pannel arriere à l'armoire à l'aide
de boulons, de rondelles et d'écrous.
(17,18,19)*

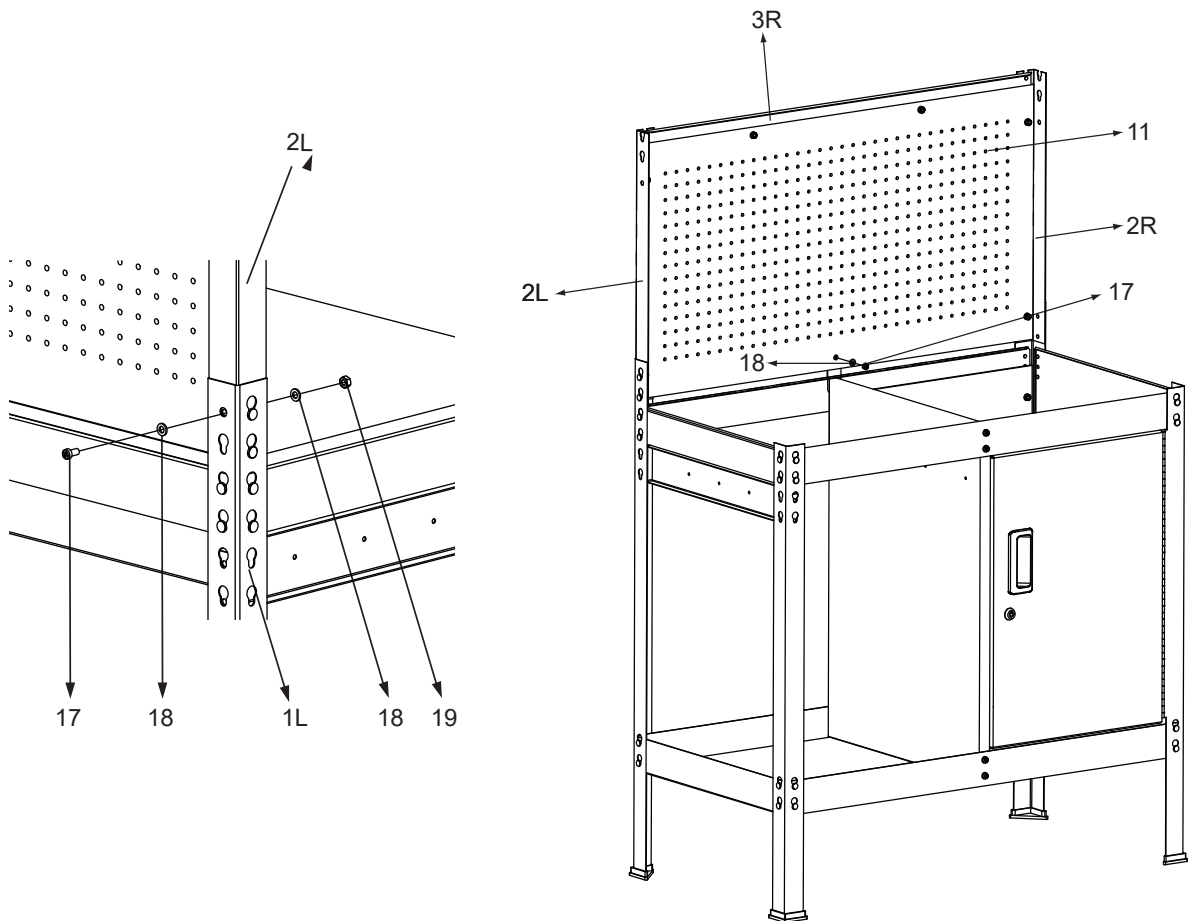
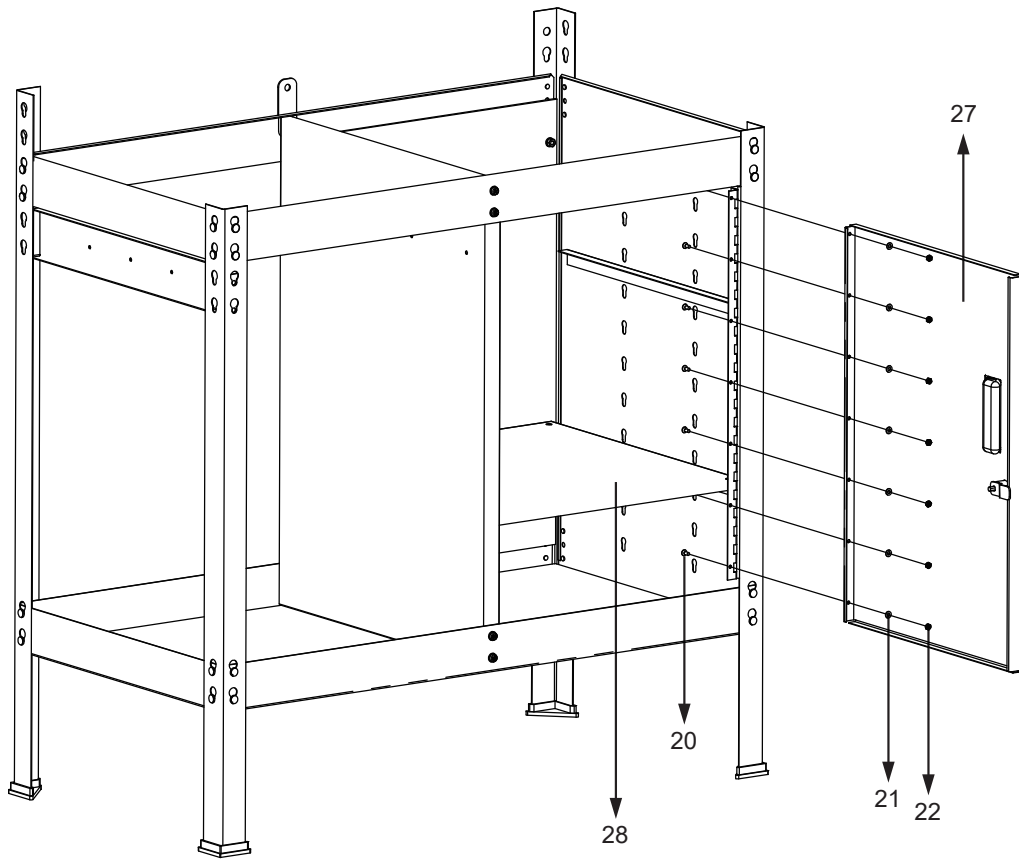

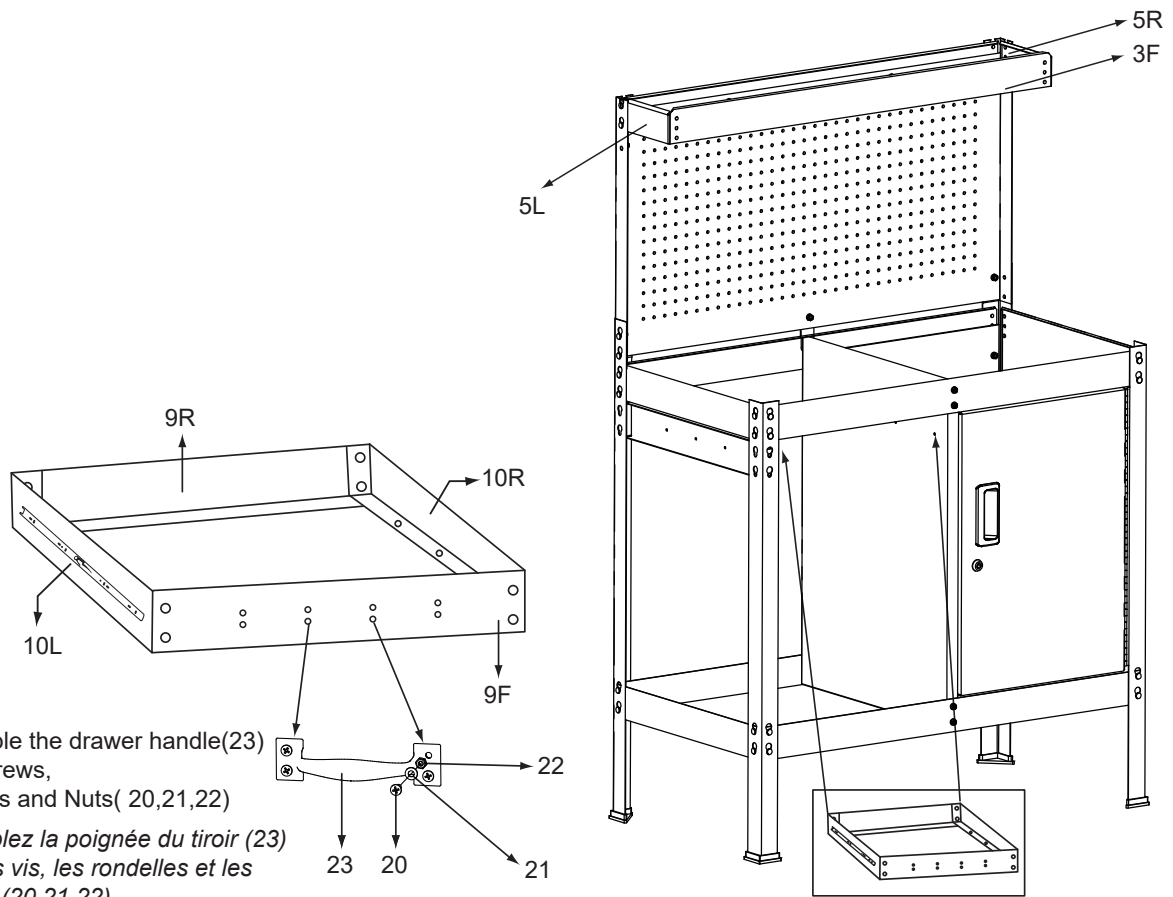

Assemble the drawer handle(23) with Screws, Washers and Nuts(20,21,22)
Assemblez la poignée du tiroir (23) avec les vis, les rondelles et les écrous. (20,21,22)

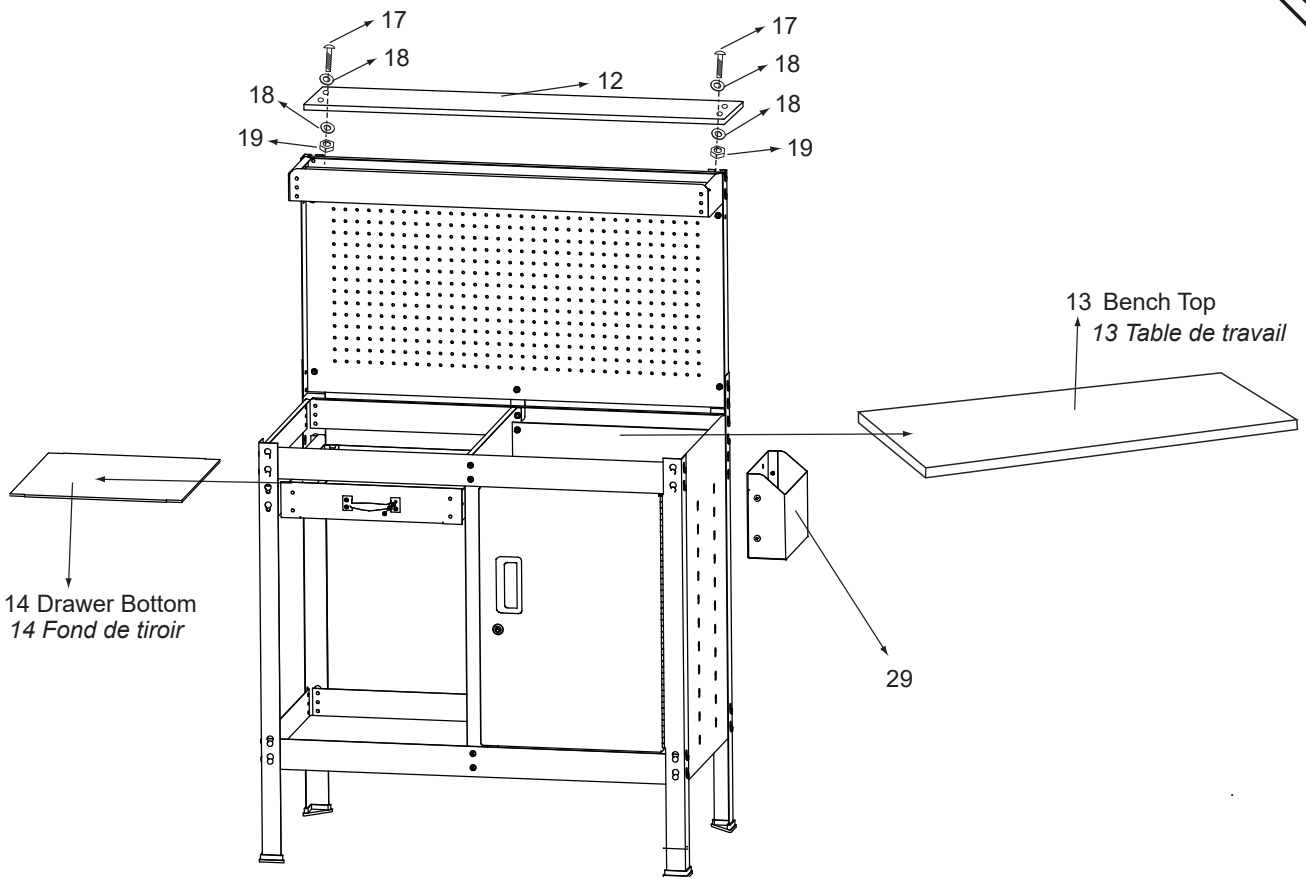

14 Drawer Bottom
14 Fond de tiroir

13 Bench Top
13 Table de travail

US



001-877-644-9366
customerservice@aosom.com

CA



001-855-537-6088
customerservice@aosom.ca

UK



0044-800-240-4004
enquiries@mhstar.co.uk

DE



0049-(0)40-88307530
service@aosom.de

FR



0033-1-84166106
contact@aosom.fr

ES



0034-931294512
atencioncliente@aosom.es

IT



0039-0249471447
clienti@aosom.it