

836-056BK/836-056WT

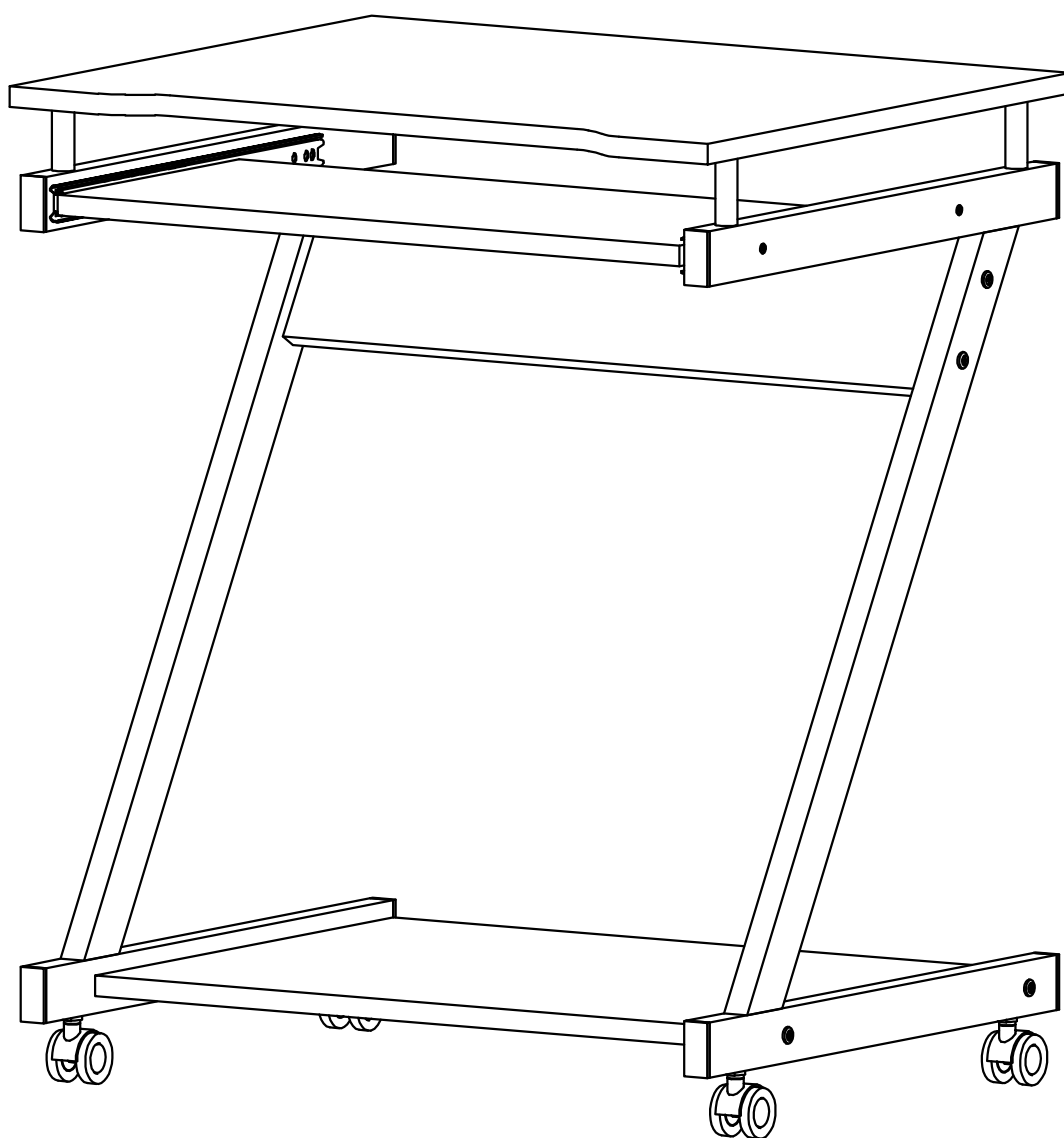

OPERATING INSTRUCTIONS

ASSEMBLY INSTRUCTION

Decomposition of components

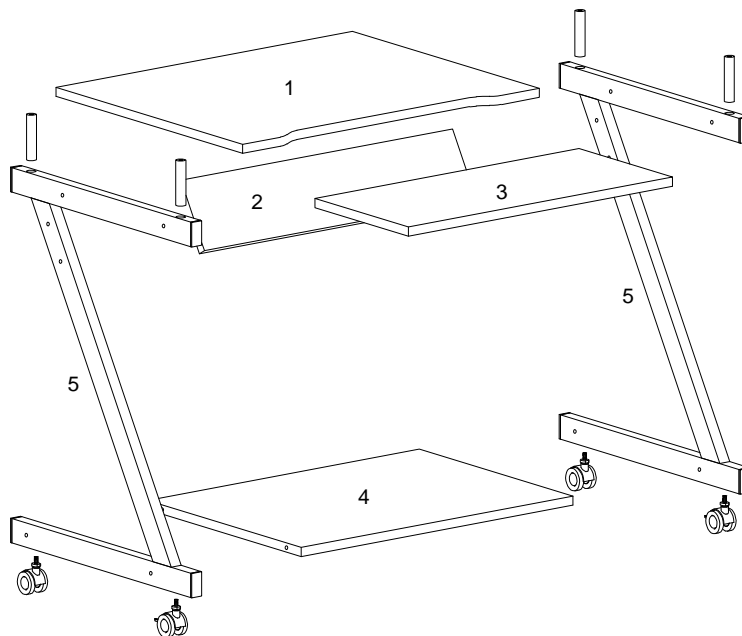

Please check the board number and Qty

1	2	3	4
1 pc	1 pc	1 pc	1 pc
5	6	7	8
2 pcs			
A	B	C	D
M5*50	M6*100		M4*25
8 pcs	4 pcs	2 pcs	4 pcs
E	F	G	H
M4		M4*12	
4 pcs	2 pcs	4 pcs	4 pcs

Disassembly and installation of accessories

"C" hardware disassembly example

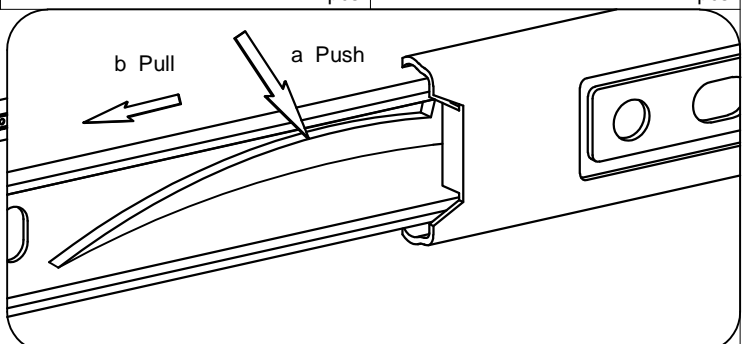
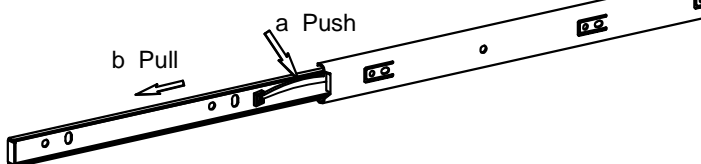

ASSEMBLY INSTRUCTION

STEP 1

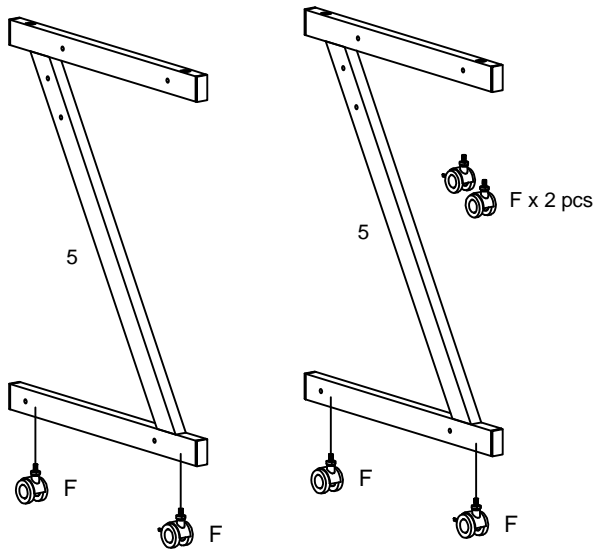

STEP 2

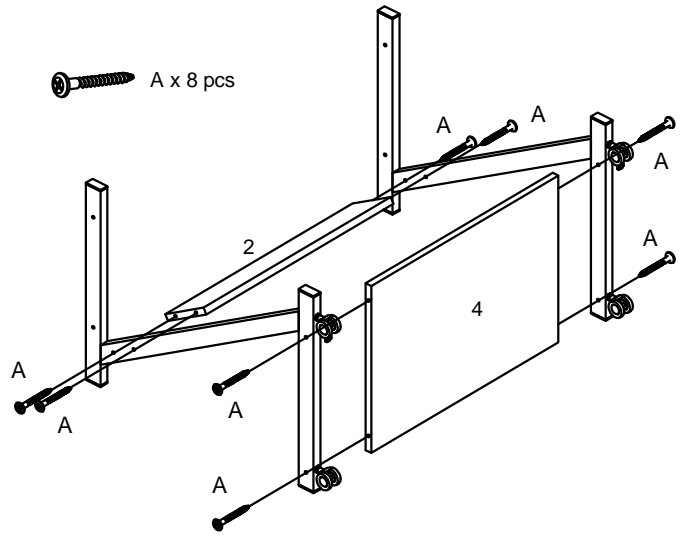

STEP 3

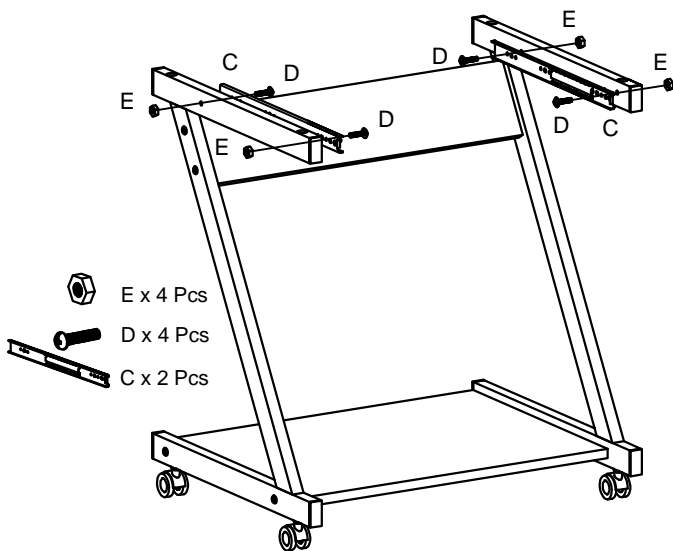

STEP 4

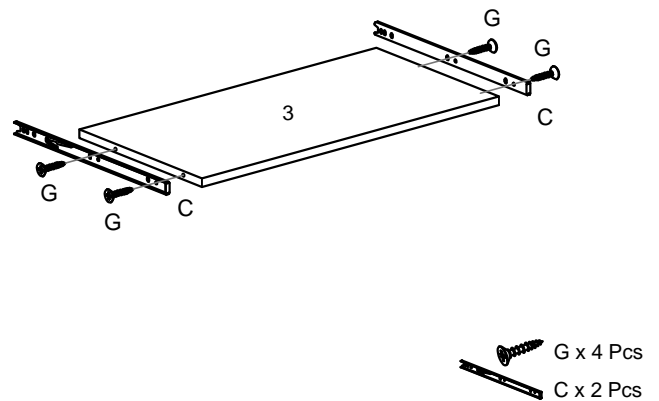

STEP 5

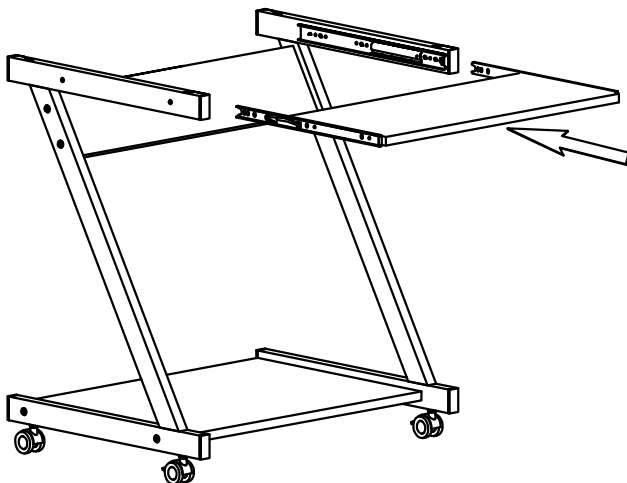

STEP 6

