

Tools Recommended

EN_IMPORTANT, RETAIN FOR FUTURE REFERENCE: READ CAREFULLY.





FR_IMPORTANT: A LIRE ATTENTIVEMENT ET À CONSERVER POUR CONSULTATION ULTÉRIEURE.

ES_IMPORTANTE, LEA Y GUARDE PARA FUTURAS REFERENCIAS.



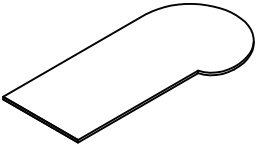

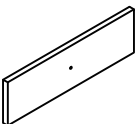
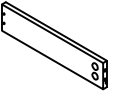
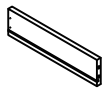

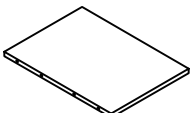
DE_WICHTIG! SORGFÄLTIG LESEN UND FÜR SPÄTER NACHSCHLAGEN AUFBEWAHREN.

IT_IMPORTANTE! CONSERVARE IL PRESENTE MANUALE PER FUTURO RIFERIMENTO E LEGGERLO ATTENTAMENTE.

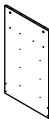
BOX-1/2

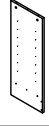
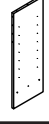
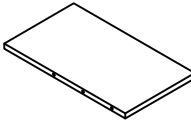
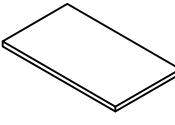
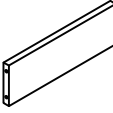
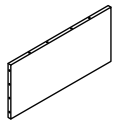
NO.	PARTS	QTY
①		1
⑮		1
⑭		1
⑯		3
⑰		3
⑱		3
⑲		3
⑬		1
⑧		1

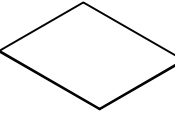
BOX-2/2

NO.	PARTS	QTY
②		1
③		1
④		1
⑤		1
⑥		1
⑨		1
⑩		1
⑪		2
⑦		1
⑫		1
⑳		3
 Hardware Kit		

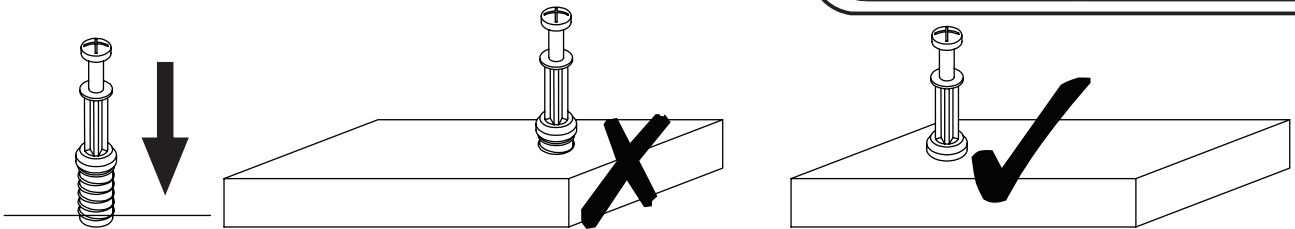

EN_QUICKFIT: Tighten quickfit until shoulder is flush with panel. Do not overtighten or undertighten.

FR_RACCORD RAPIDE: Faites serrer le raccord rapide jusqu'à ce que l'épaulement soit parfaitement encastré dans le panneau. Il ne faut ni trop serrer ni insuffisamment serrer.

ES_QUICKFIT: Apriete quickfit hasta que el hombro se descargue con el panel. NO lo sobreapriete ni lo apriete poco.

DE_QUICKFIT: Ziehen Sie den Quickfit fest, bis die Schulter mit der Platte bündig ist. Bitte nicht zu fest oder zu schwach anziehen.

IT_MONTAGGIO RAPIDO: Stringere il montaggio rapido fino a quando la spalla è a filo con il pannello, non stringere troppo o troppo poco.

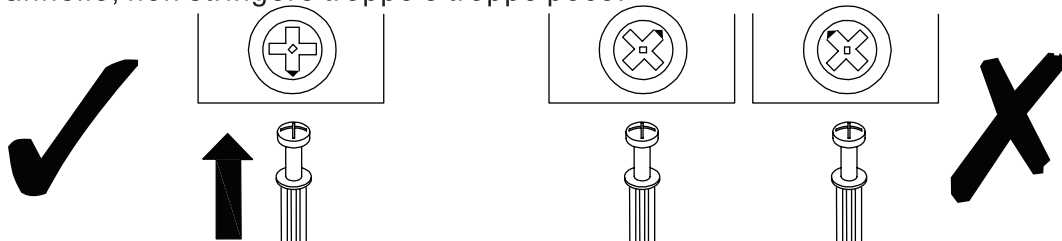

EN_CAM LOCK: When fitting cam lock, ensure starting position is correct before you insert connecting quickfit.

FR_SERRURE BATTEUSE: Avant d'insérer la serrure batteuse, veillez à la bonne orientation avant d'insérer le raccord rapide.

ES_CIERRE DE LA CÁMARA: Cuando instale el cierre de la cámara, asegúrese de que la posición de inicio es correcta antes de que inserte el quickfit conector.

DE_CAM-LOCK: Achten Sie bei der Montage des Cam-Locks auf die richtige Ausgangsposition, bevor Sie den Quickfit einsetzen.

IT_BLOCCAGGIO A CAMMA: Quando si monta il bloccaggio a camma, assicurarsi che la posizione iniziale sia corretta prima di inserire il montaggio rapido di collegamento.

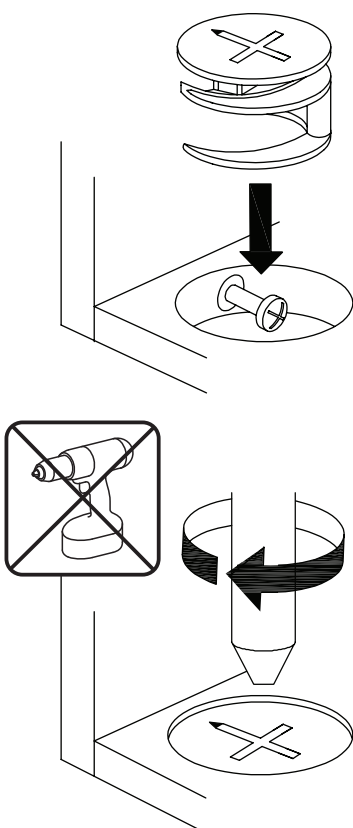

EN_Quickfit head should be in the centre of the cam lock when the two panels are joined.

Cam lock should be inserted before quickfit.

FR_Lorsque les deux panneaux sont assemblés, la tête du raccord rapide doit reposer au centre de la serrure batteuse. Il faut insérer la serrure batteuse avant le raccord rapide.

ES_El cabezal del quickfit debe estar en el centro del cierre de la cámara cuando se unan los dos paneles.

Se debe insertar el cierre de la cámara antes que el quickfit.

DE_Der Quickfit-Kopf sollte sich in der Mitte des Cam-Locks befinden, wenn die beiden Platten zusammengefügt sind. Der Cam-Lock sollte vor dem Quickfit eingesetzt werden.

IT_La testa del montaggio rapido deve trovarsi al centro del bloccaggio a camma quando i due pannelli sono uniti.

Il Bloccaggio a Camma deve essere inserito prima del montaggio rapido.

EN_Turn cam lock clockwise to tighten.

FR_Faites tourner la serrure batteuse dans le sens des aiguilles d'une montre pour la resserrer.

ES_Gire el cierre de la cámara en sentido horario para apretarlo.

DE_Drehen Sie den Cam-Lock im Uhrzeigersinn, um ihn festzuziehen.

IT_Ruotare il bloccaggio a camma in senso orario per stringere.

EN_NOTE: Pull inner and outer drawer runners apart before fixing them to panels.

FR_REMARQUE: Avant de fixer les glissières de tiroir aux panneaux, tirez vers l'extérieur et poussez vers l'intérieur de chacun des tiroirs.

ES_NOTA: retire los rieles interiores y exteriores antes de fijarlos a los paneles.

DE_HINWEIS: Ziehen Sie die inneren und äußeren Schubladenführung auseinander, bevor Sie sie an den Platten befestigen.

IT_NOTA: Separare le guide interne ed esterne del cassetto prima di fissarle ai pannelli.

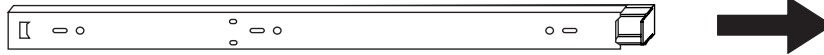

EN_Slide drawer runners apart until the drawer lock can be seen, as shown.

FR_Les glissières de tiroir doivent être ouvertes jusqu'à ce que la serrure du tiroir soit visible, comme indiqué.

ES_Deslice a un lado los rieles del cajón hasta que se pueda ver el cierre del armario, tal y como se muestra.

DE_Schieben Sie die Schubladenführungen auseinander, bis das Schubladenschloss sichtbar ist, gemäß der Abbildung.

IT_Far scorrere le guide del cassetto fino a quando non sia visibile il blocco di scorrimento, come mostrato.

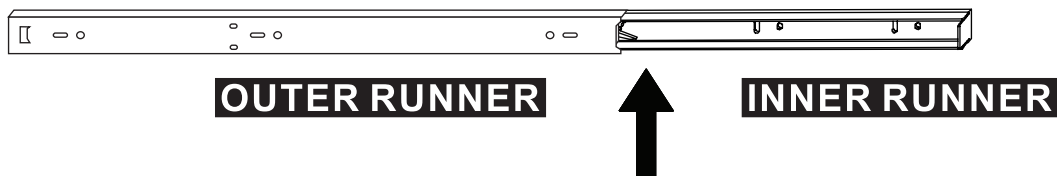

EN_Press and hold the drawer runner lock and then continue to slide drawer runners apart, as shown.

FR_En appuyant et en maintenant le verrouillage des glissières de tiroir, vous pouvez continuer à les écarter l'une de l'autre, comme indiqué.

ES_Mantenga presionado el cierre del riel del cajón y después continúe deslizando a un lado los rieles de los cajones, tal y como se muestra.

DE_Drücken und halten Sie die Verriegelung der Schubladenführung und schieben Sie die Schubladenführungen wie abgebildet weiter auseinander.

IT_Tenere premuto il blocco di scorrimento e quindi continuare a far scorrere la guida, come mostrato.

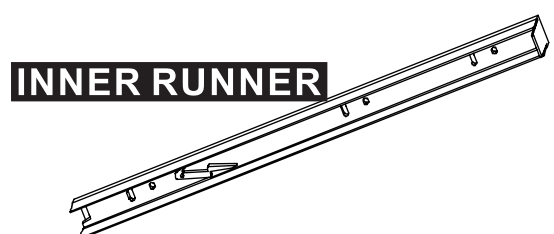
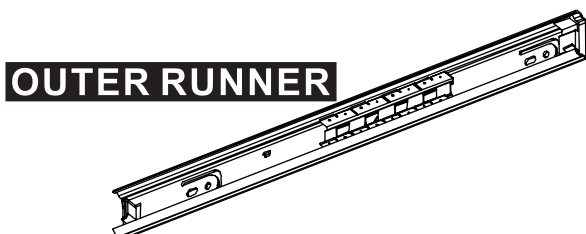
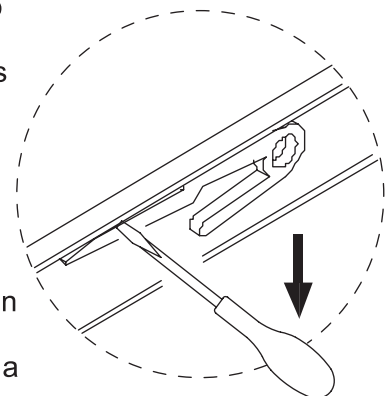

EN_Your inner and outer drawer runners are ready to be fixed to panels.

FR_Il est possible, à présent, de fixer les glissières intérieures et extérieures de vos tiroirs sur des panneaux.

ES_Los rieles interiores y exteriores del cajón están listos para fijarse a los paneles.

DE_Ihre inneren und äußeren Schubladenführungen sind bereit, an den Platten befestigt zu werden.

IT_Le guide interne ed esterne sono pronte per essere fissate ai pannelli.

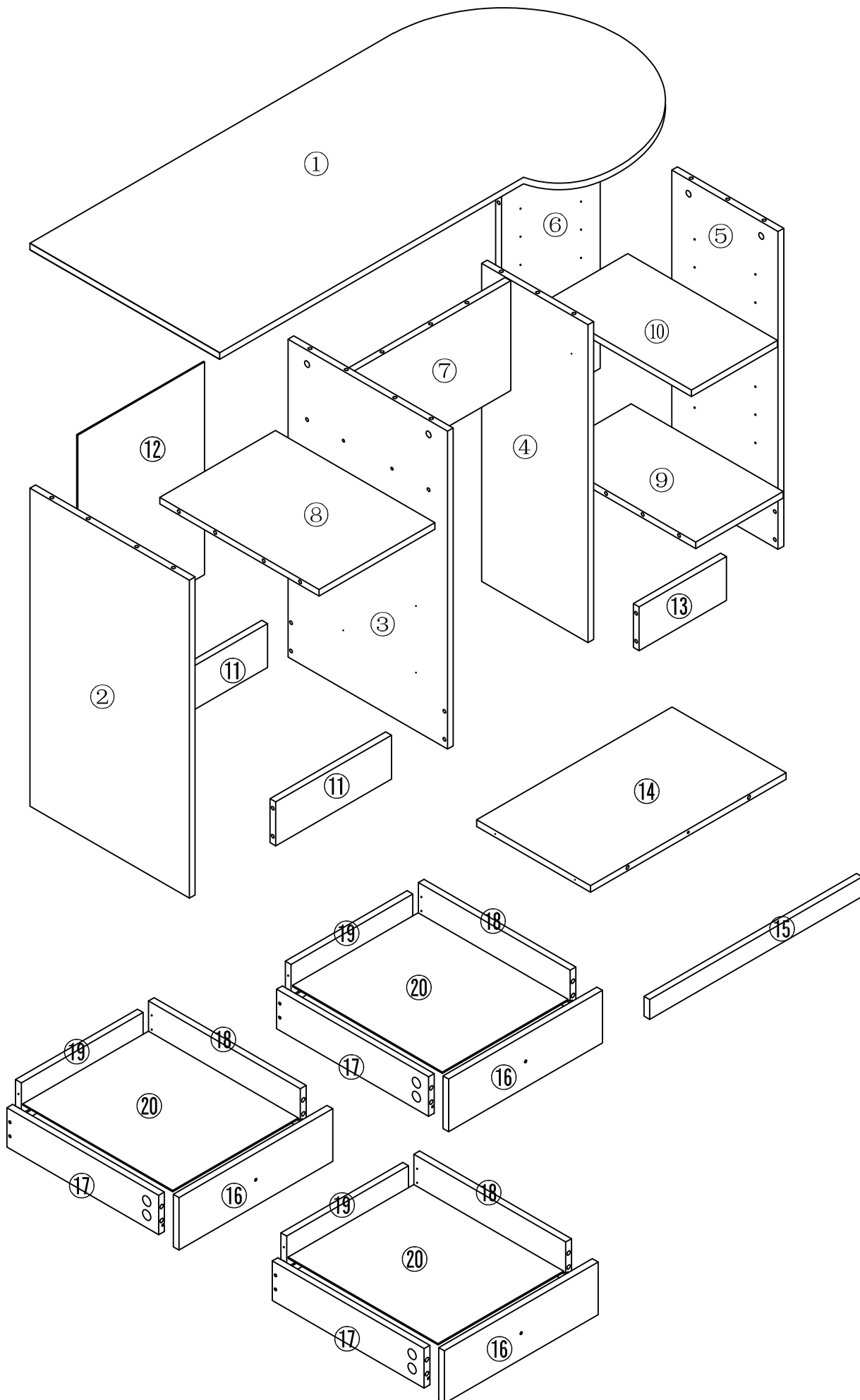

A x52
+2(spare)

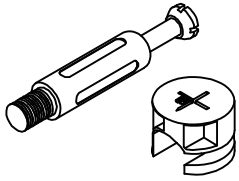

B x21
Φ8*40
+1(spare)

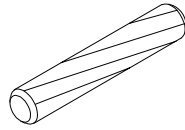

C x03

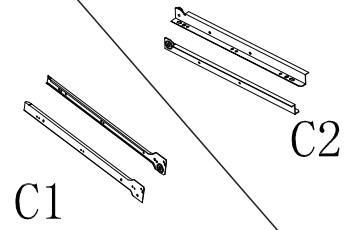

D x01

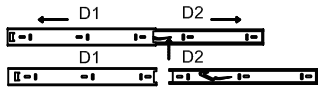

E x32
Φ3.5*14
+2(spare)



F x12
Φ3.5*35
+1(spare)

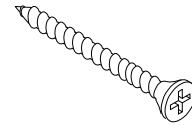

G x06

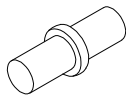

H x03
Φ4*18

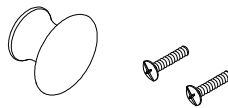

I x12

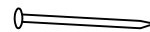

J x10

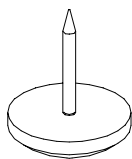

K x52
Φ20



- 2** x01
- 3** x01
- 8** x01
- 11** x02
- A** x12
- B** x04
- K** x12

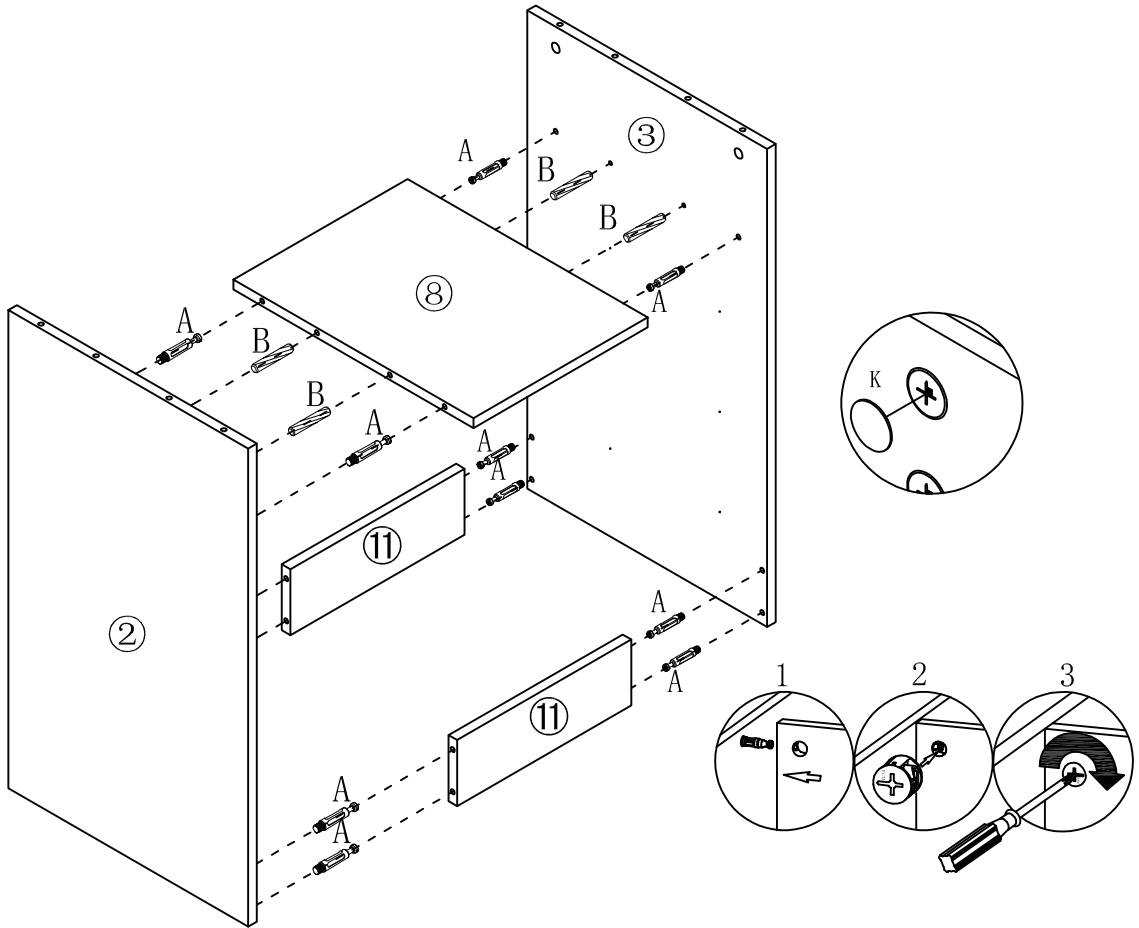

- 4** x01
- 5** x01
- 9** x01
- 13** x01
- A** x08
- B** x02
- K** x08

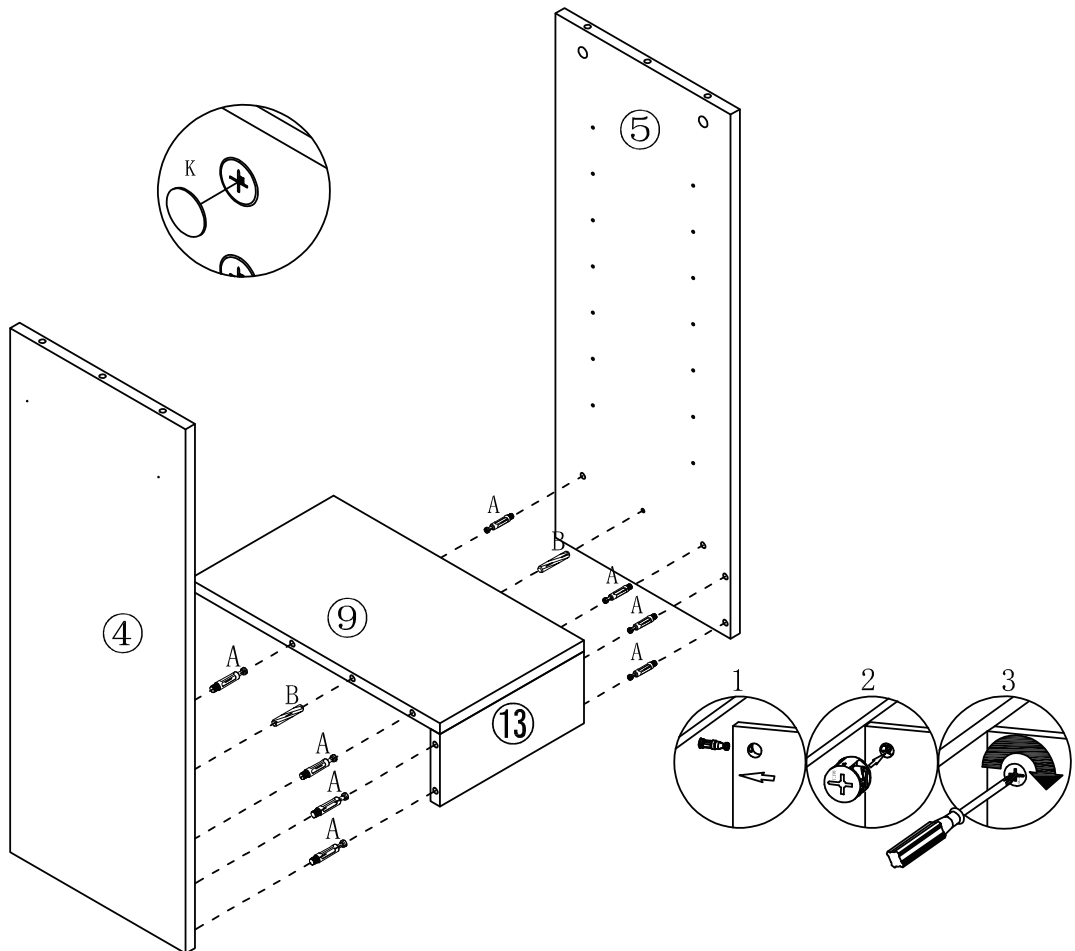

⑥ x01

A x02

B x01

K x02

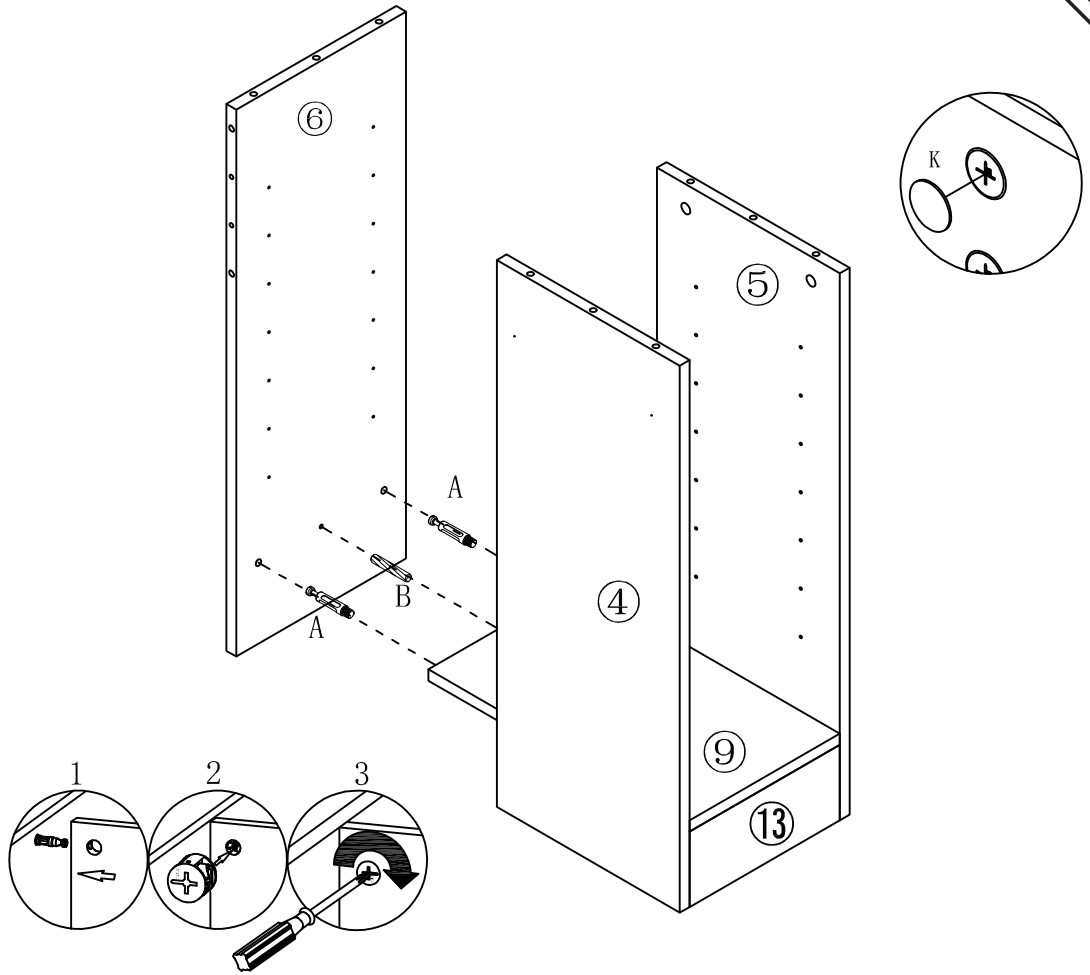

⑦ x01

⑫ x01

A x04

B x04

I x12

K x04

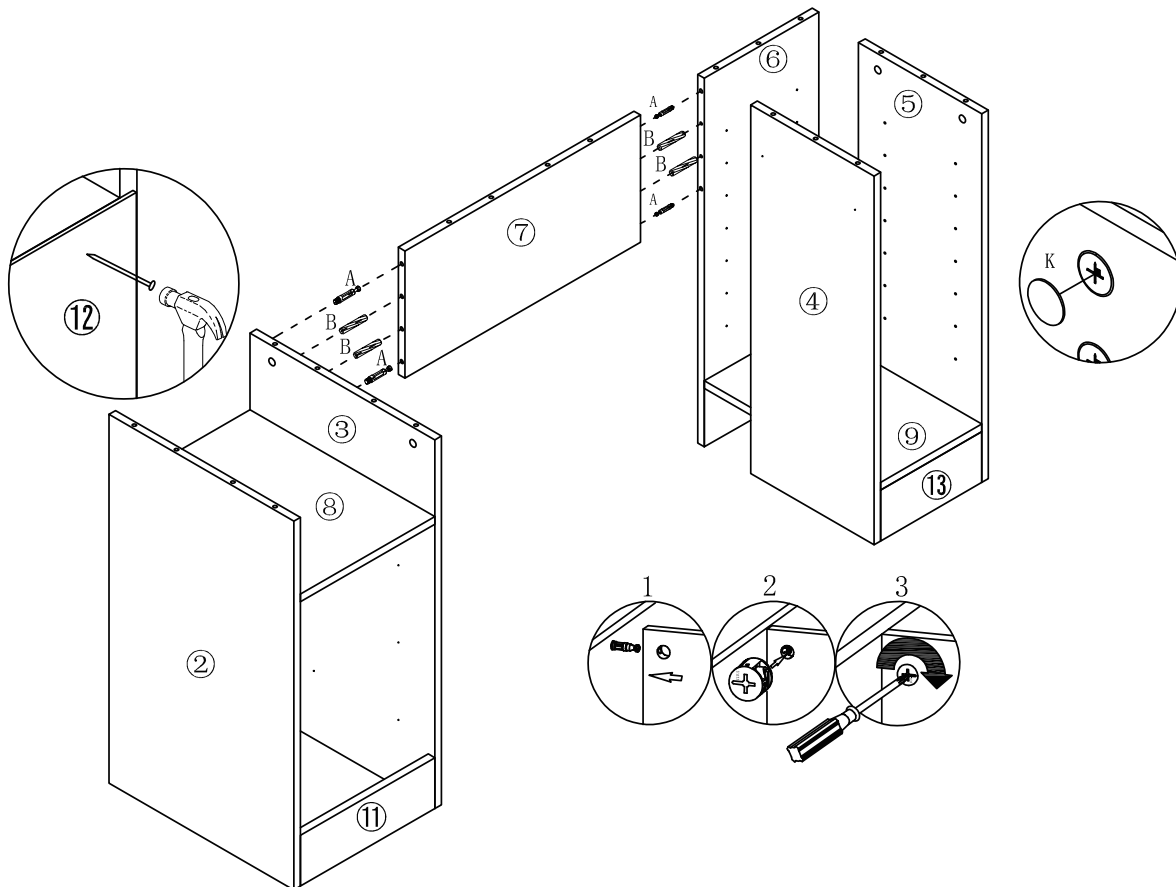

- 1** x01
- A** x12
- B** x09
- K** x12

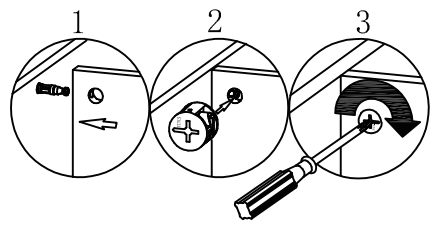
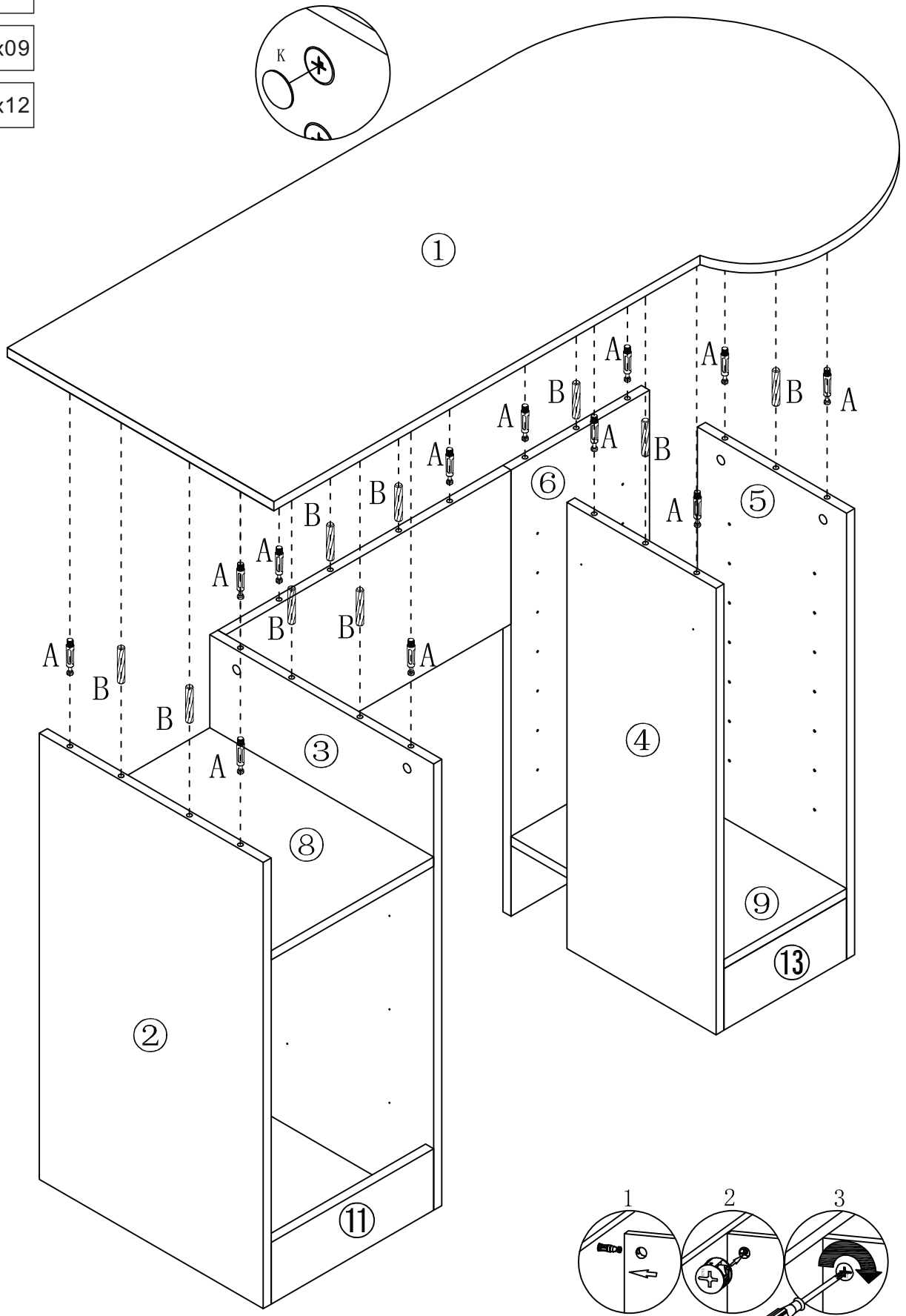

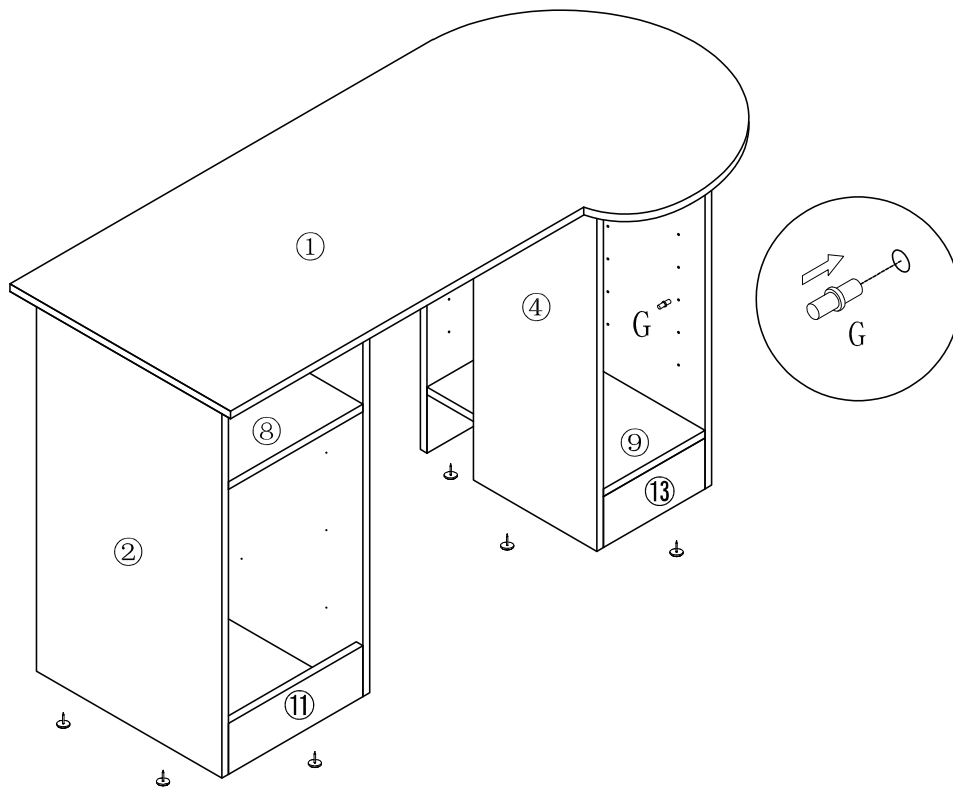
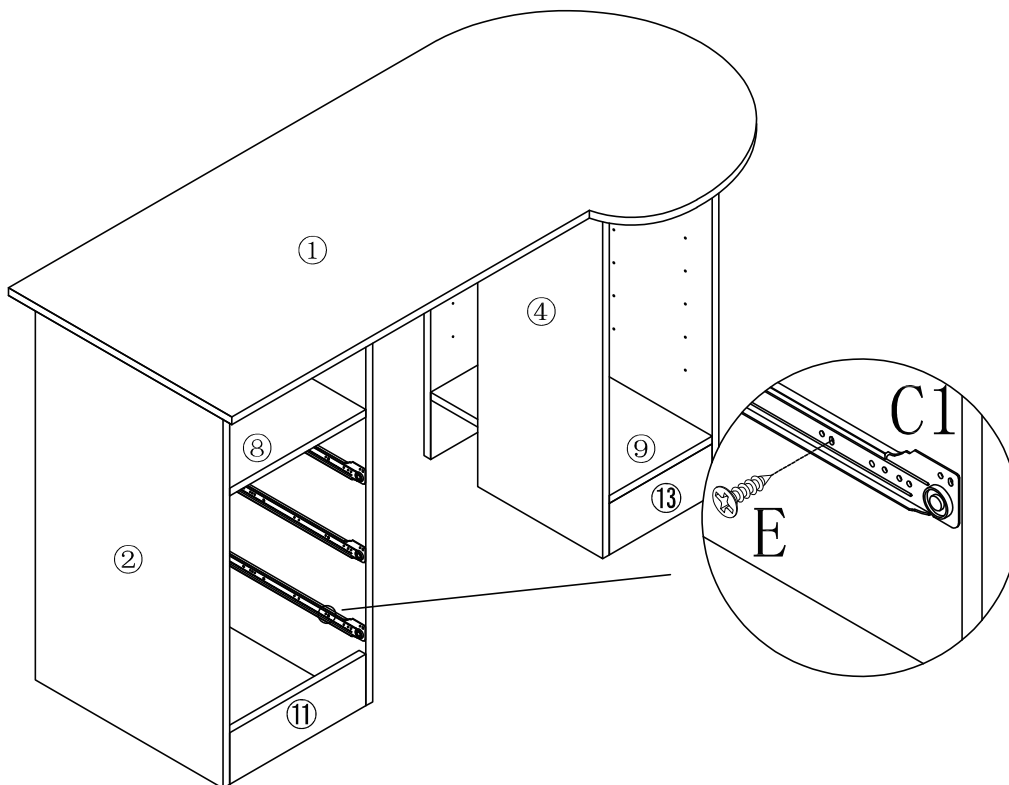
G x06**J** x10**C1** x03**E** x12

EN Please find the exact hole for installation, otherwise it will be misaligned. The screws on the drawer slide must be leveled, otherwise it will affect the smoothness of the drawer.

FR Veuillez repérer le trou exact pour l'installation, sinon il sera mal aligné. Les vis de la glissière du tiroir doivent être nivelées, sinon cela affectera la douceur du tiroir.

ES Encuentre el orificio exacto para la instalación; de lo contrario, estará desalineado. Los tornillos de la guía del cajón deben estar nivelados, de lo contrario afectará a la suavidad del cajón.

DE Bitte benutzen Sie die exakten Bohrungen für die Installation, sonst wird sie falsch ausgerichtet. Die Schrauben an der Schubladenföhrung müssen nivelliert werden, da sie sonst die Leichtgängigkeit der Schublade beeinträchtigen.

IT Si prega di individuare il foro corretto per l'installazione, altrimenti sarà disallineato. Le viti della guida del cassetto devono essere livellate, altrimenti la scorrevolezza del cassetto ne risentirà.

D1 x02

E x04

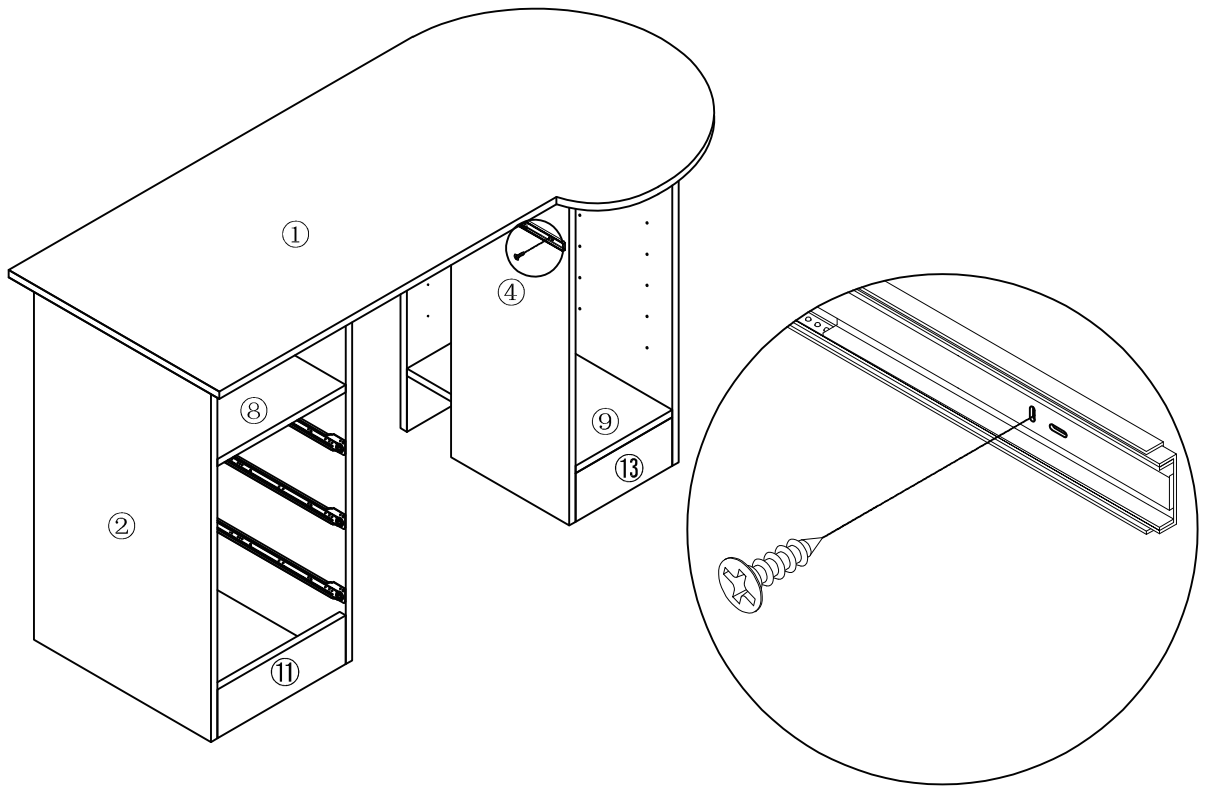

14 x01

15 x01

A x02

B x01

D2 x02

E x04

K x04

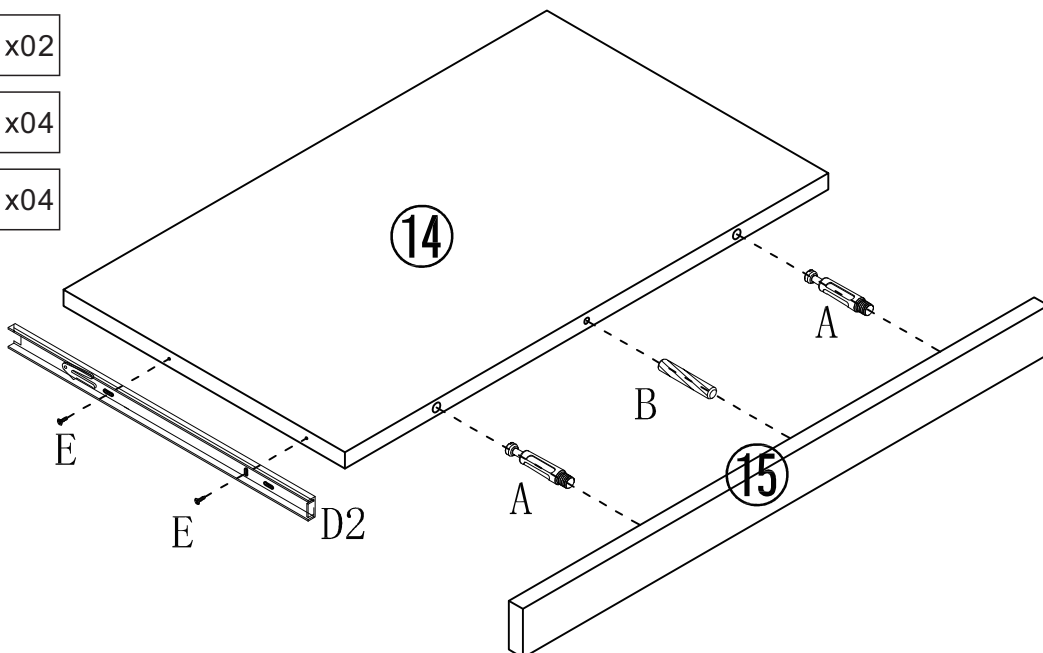
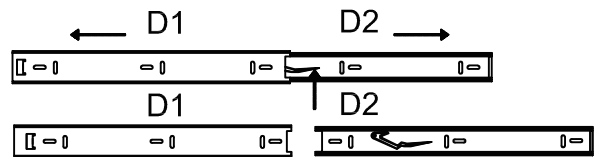

16 x03

17 x03

18 x03

19 x03

20 x03

A x12

C2 x06

E x12

F x12

H x03

K x12

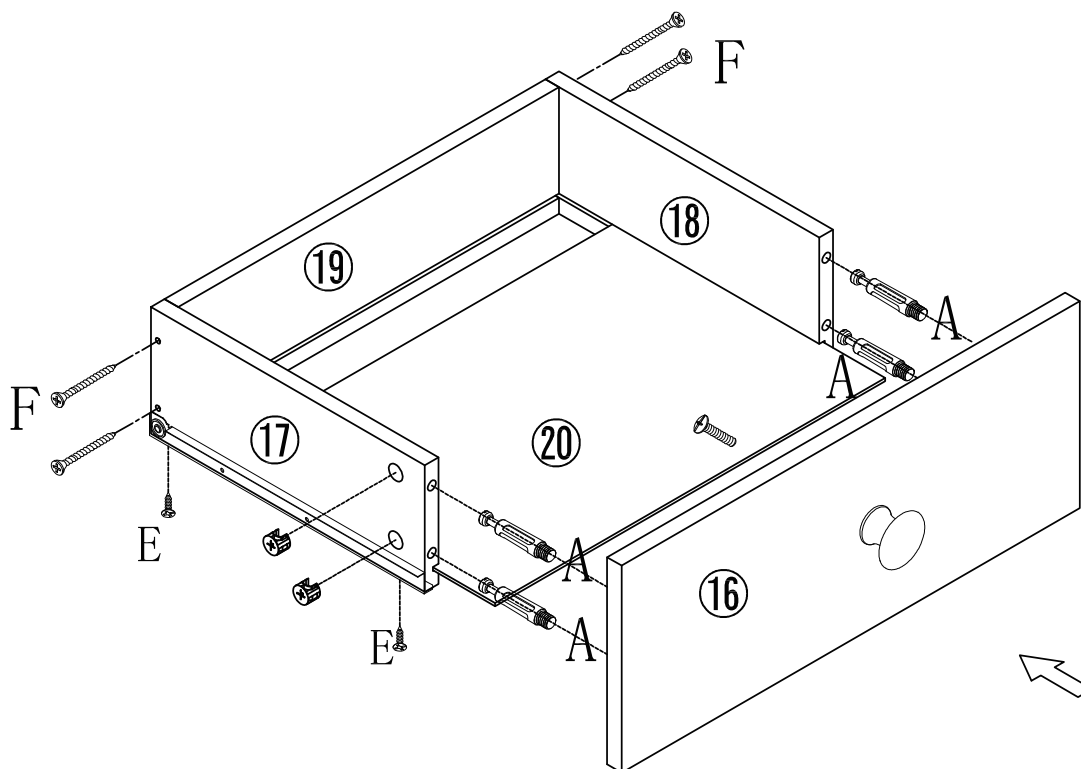

x3

Done

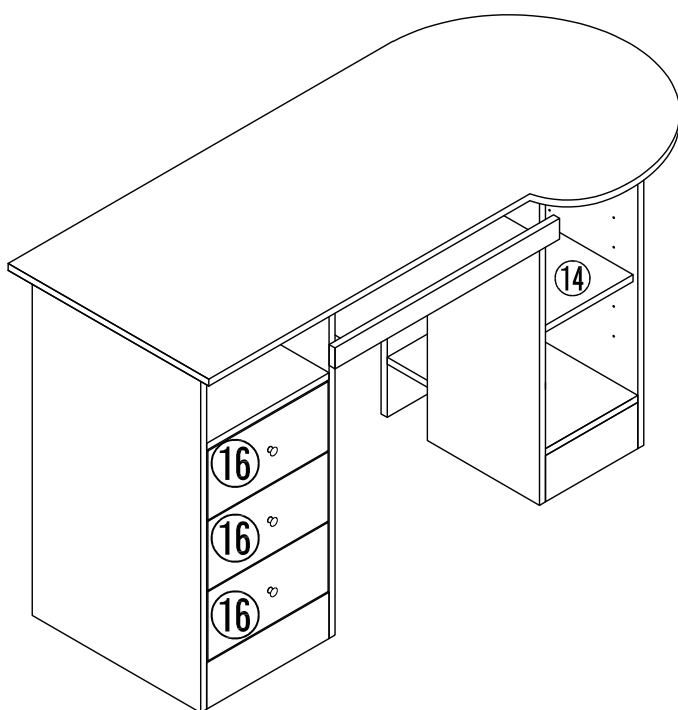

EN_Be careful to push in the board when the both sides slide way been aligned.

FR_Prenez soin d'enfoncer la carte lorsque les deux côtés coulissants sont alignés.

ES_Tenga cuidado al empujar el tablero cuando los ambos lados se hayan alineado.

DE_Achten Sie darauf, dass Sie die Platte einschieben, wenn der Gleitweg auf beiden Seiten ausgerichtet ist.

IT_Prestare attenzione quando si spinge l'asse se entrambi i lati sono allineati.