

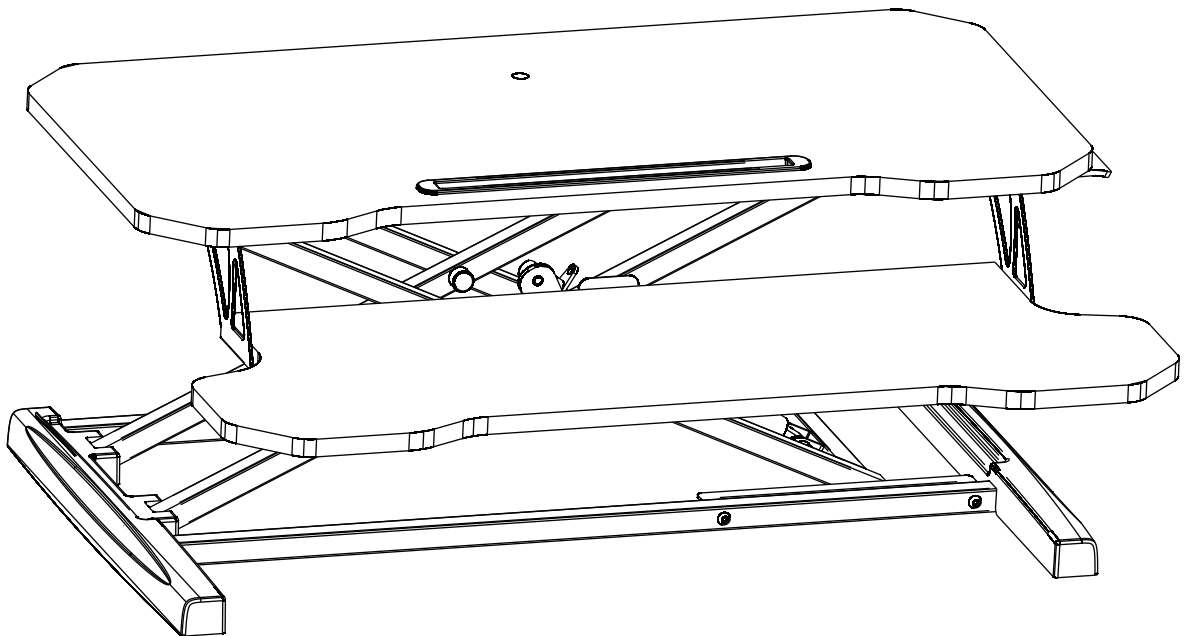

INcka032_CA_UK_FR_ES

923-043



Desktop



Work Surface

IMPORTANT, RETAIN FOR FUTURE REFERENCE: READ CAREFULLY

ASSEMBLY & INSTRUCTION MANUAL

WARNING!

If you do not understand these directions, or if you have any doubts about the safety of the installation, please call a qualified technician. Check carefully to make sure there are no missing or defective parts. Improper installation may cause damage or serious injury. Do not use this product for any purpose that is not explicitly specified in this manual and do not exceed weight capacity. We cannot be liable for damage or injury caused by improper mounting, incorrect assembly, or inappropriate use.

TOOLS NEEDED

DO NOT EXCEED WEIGHT CAPACITY.

FAILURE TO DO SO MAY RESULT IN SERIOUS INJURY

WARNING

PINCH POINT

DO NOT place hands on or near support bars. Moving parts can crush and cut. Pinch points are created during lifting and lowering the worksurface. Failure to follow these instructions may result in serious personal injury.



Screwdriver

AVERTISSEMENT !

Si vous ne comprenez pas ces instructions, ou si vous avez des doutes sur la sécurité de l'installation, veuillez appeler un technicien qualifié. Vérifiez soigneusement qu'il n'y a pas de pièces manquantes ou défectueuses. Une installation incorrecte peut causer des dommages ou des blessures graves. N'utilisez pas ce produit à des fins qui ne sont pas explicitement spécifiées dans ce manuel et ne dépassez pas la capacité de poids. Nous ne pouvons pas être tenus responsables des dommages ou des blessures causés par un montage incorrect, un assemblage incorrect ou une utilisation inappropriée.

OUTILS NÉCESSAIRES

NE PAS DÉPASSER LA CAPACITÉ DE CHARGE

LE NON-RESPECT DE CETTE CONSIGNE PEUT ENTRAÎNER DES BLESSURES GRAVES

AVERTISSEMENT

POINT DE PINCEMENT

NE PAS placer les mains sur ou près des barres de support. Les pièces mobiles peuvent écraser et couper les doigts. Des points de pincement sont créés lors du levage et de l'abaissement de la surface de travail. Le non-respect de ces instructions peut entraîner des blessures graves.



Tournevis



¡ADVERTENCIA!

Si vous ne comprenez pas ces instructions, ou si vous avez des doutes sur la sécurité de l'installation, veuillez appeler un technicien qualifié. Vérifiez soigneusement qu'il n'y a pas de pièces manquantes ou défectueuses. Une installation incorrecte peut causer des dommages ou des blessures graves. N'utilisez pas ce produit à des fins qui ne sont pas explicitement spécifiées dans ce manuel et ne dépassez pas la capacité de poids. Nous ne pouvons pas être tenus responsables des dommages ou des blessures causés par un montage incorrect, un assemblage incorrect ou une utilisation inappropriée.

HERRAMIENTAS NECESARIAS

NO EXCEDA LA CAPACIDAD DE PESO DEL PRODUCTO.

NO CUMPLIRLO PUEDE PROVOCAR LESIONES GRAVES

ADVERTENCIA

PUNTO DE PELLIZCO

NO ponga sus manos sobre las barras de soporte ni cerca de ellas. Las piezas móviles pueden aplastar y cortar sus manos. Los puntos de pellizco se crean al elevar o descender la superficie de trabajo. No seguir las instrucciones puede provocar lesiones personales graves.



Destornillador

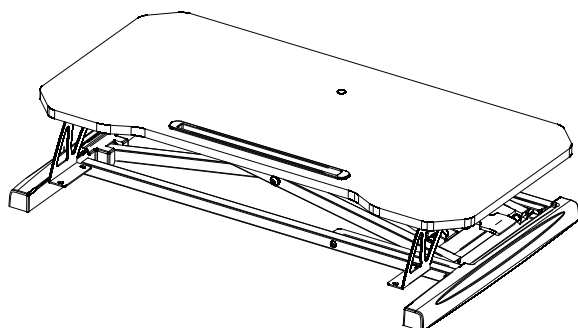

A (x1)

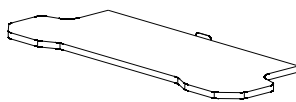

B (x1)

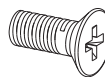

C (x4)



D (x3)



E (x2)



F (x3)



G (x1)

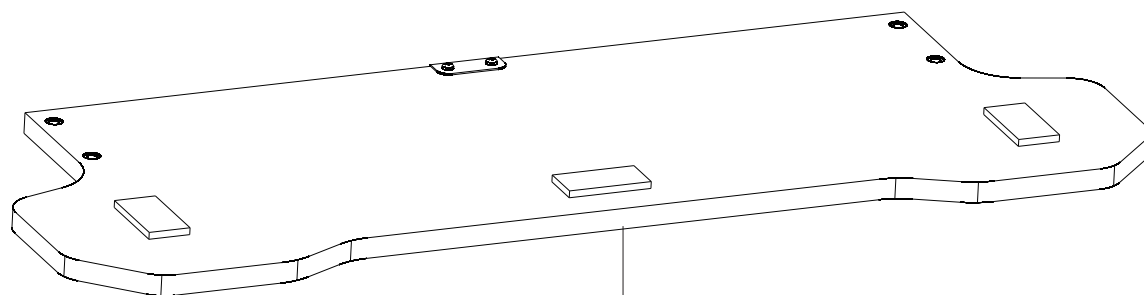
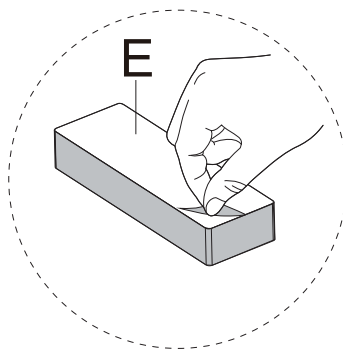

B

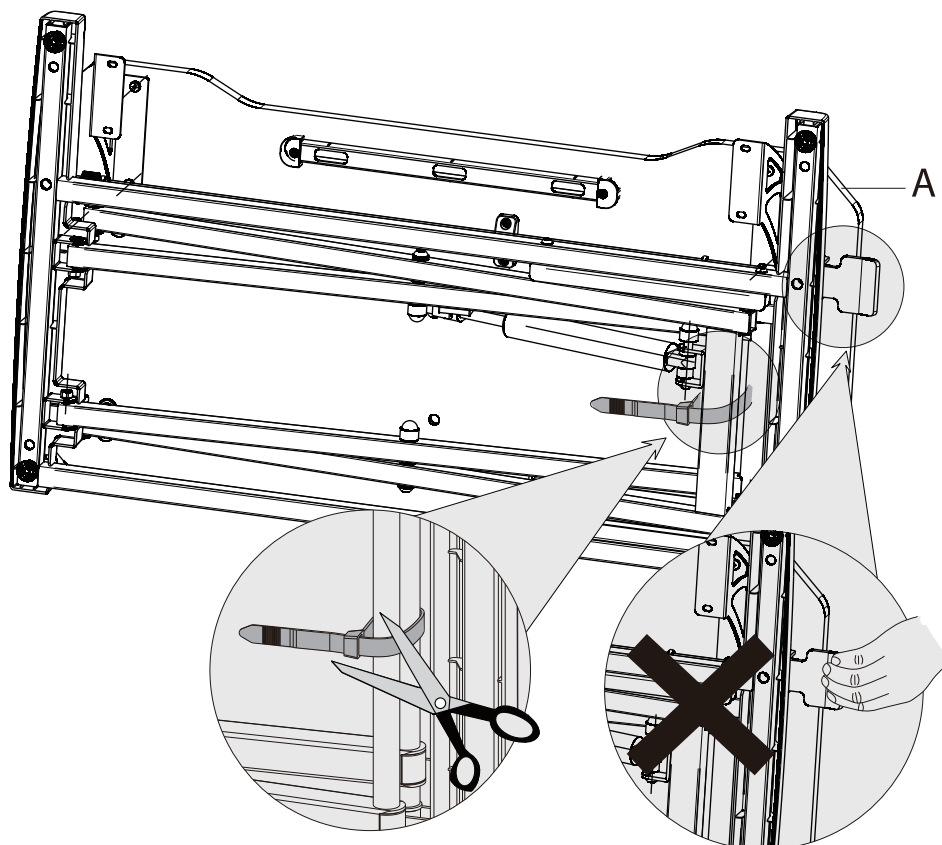

Do not press the release handle while in the package. Only press the release handle in an upright position.



Ne pas appuyer sur la poignée de déverrouillage lorsqu'elle se trouve dans l'emballage. N'appuyez sur la poignée de déverrouillage qu'en position verticale.



No presione el asa de liberación cuando está en el paquete. Presione el asa de liberación solo cuando está en posición vertical.

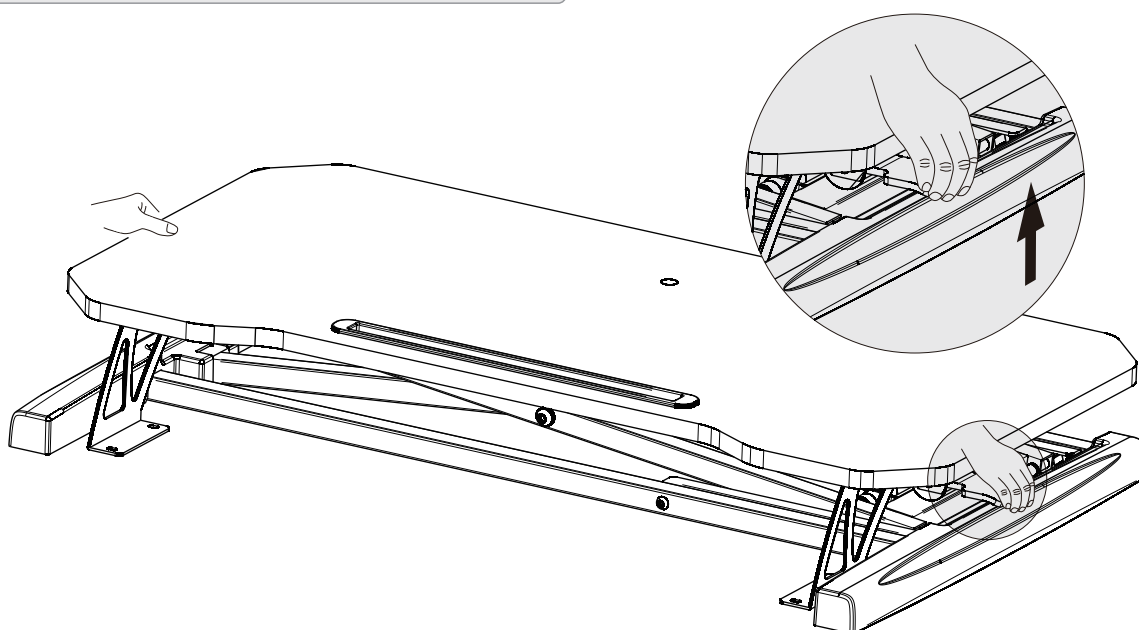

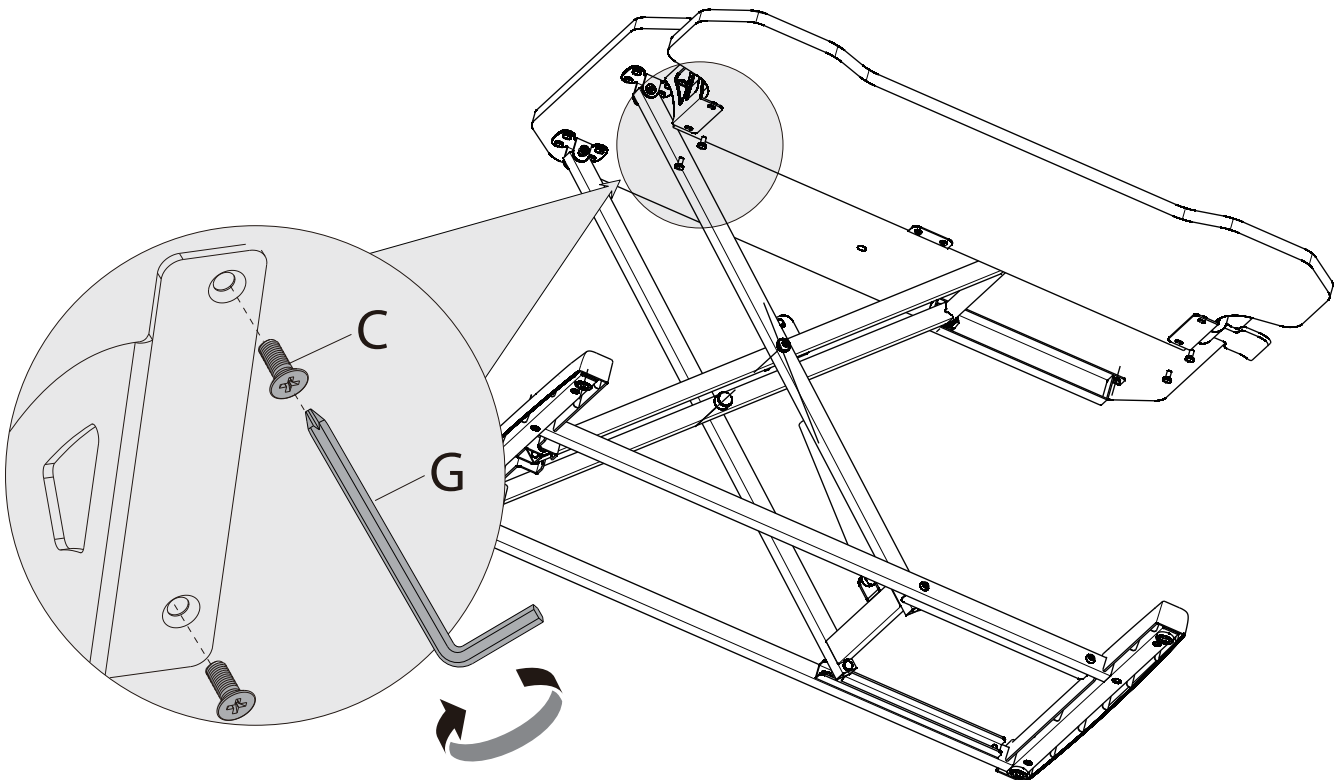
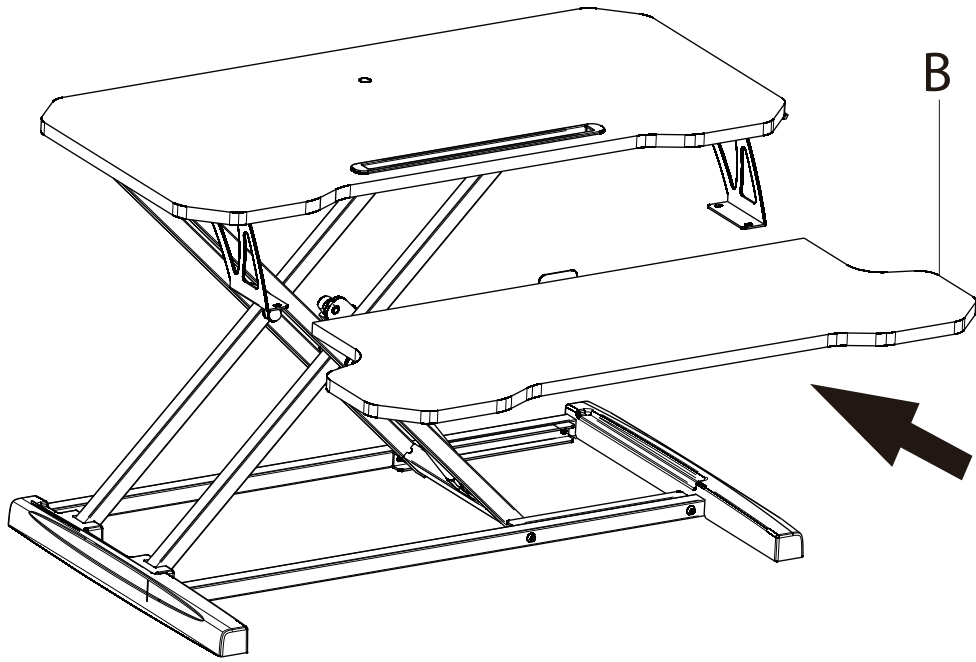

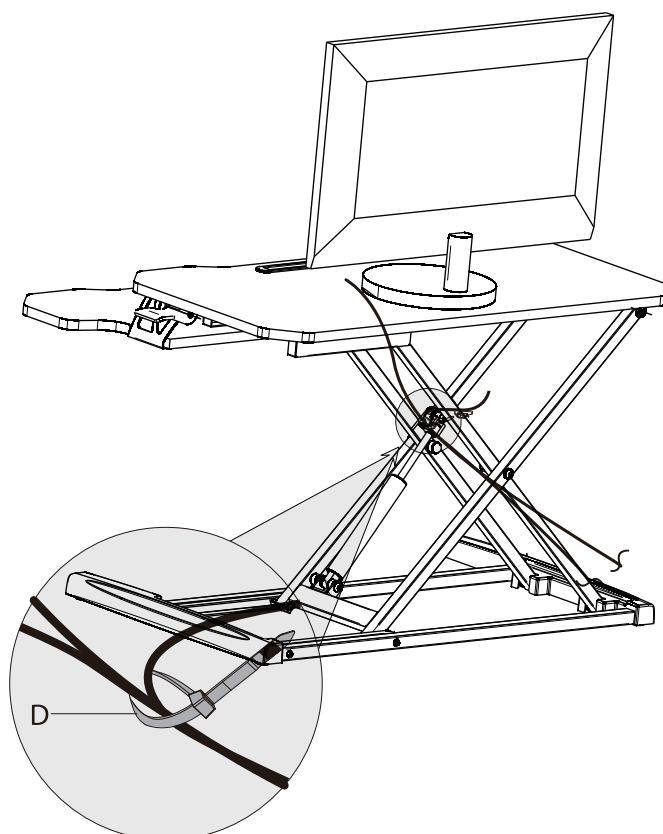
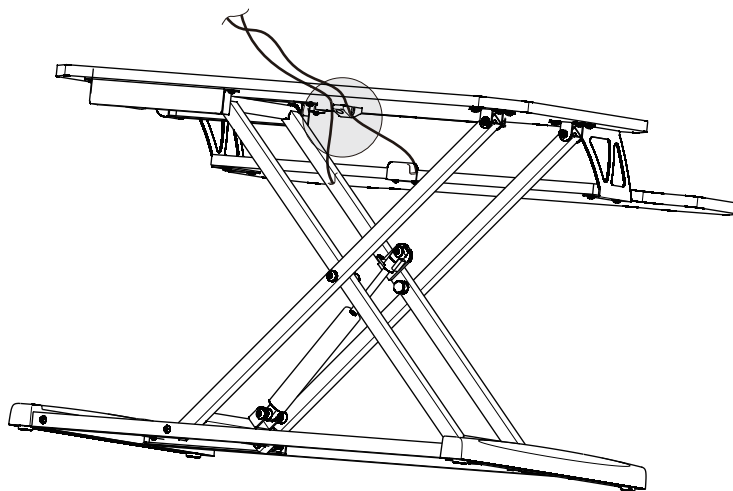
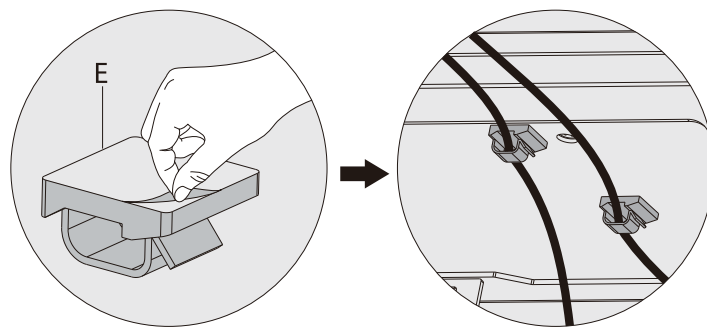

US



001-877-644-9366
customerservice@aosom.com

CA



001-855-537-6088
customerservice@aosom.ca

UK



0044-800-240-4004
enquiries@mhstar.co.uk

DE



0049-(0)40-88307530
service@aosom.de

FR



0033-1-84166106
contact@aosom.fr

ES



0034-931294512
atencioncliente@aosom.es

IT



0039-0249471447
clienti@aosom.it