

Tools Recommended

**EN\_ IMPORTANT, RETAIN FOR FUTURE REFERENCE: READ CAREFULLY.**

**FR\_ IMPORTANT: A LIRE ATTENTIVEMENT ET À CONSERVER POUR CONSULTATION ULTÉRIEURE.**

**ES\_ IMPORTANTE, LEA Y GUARDE PARA FUTURAS REFERENCIAS.**

**DE\_ WICHTIG! SORGFÄLTIG LESEN UND FÜR SPÄTER NACHSCHLAGEN AUFBEWAHREN.**

**IT\_ IMPORTANTE! CONSERVARE IL PRESENTE MANUALE PER FUTURO RIFERIMENTO E LEGGERLO ATTENTAMENTE.**

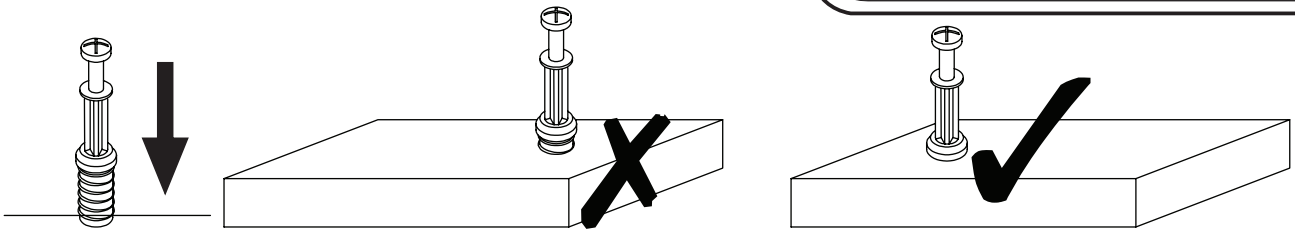

**EN\_QUICKFIT:** Tighten quickfit until shoulder is flush with panel. Do not overtighten or undertighten.

**FR\_RACCORD RAPIDE:** Faites serrer le raccord rapide jusqu'à ce que l'épaulement soit parfaitement encastré dans le panneau. Il ne faut ni trop serrer ni insuffisamment serrer.

**ES\_QUICKFIT:** Apriete quickfit hasta que el hombro se descargue con el panel. NO lo sobreapriete ni lo apriete poco.

**DE\_QUICKFIT:** Ziehen Sie den Quickfit fest, bis die Schulter mit der Platte bündig ist. Bitte nicht zu fest oder zu schwach anziehen.

**IT\_MONTAGGIO RAPIDO:** Stringere il montaggio rapido fino a quando la spalla è a filo con il pannello, non stringere troppo o troppo poco.

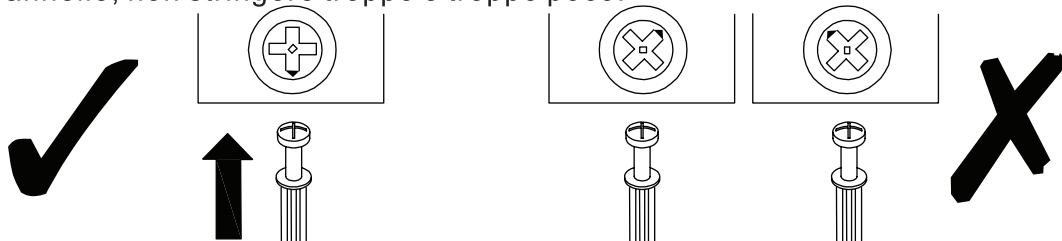

**EN\_CAM LOCK:** When fitting cam lock, ensure starting position is correct before you insert connecting quickfit.

**FR\_SERRURE BATTEUSE:** Avant d'insérer la serrure batteuse, veillez à la bonne orientation avant d'insérer le raccord rapide.

**ES\_CIERRE DE LA CÁMARA:** Cuando instale el cierre de la cámara, asegúrese de que la posición de inicio es correcta antes de que inserte el quickfit conector.

**DE\_CAM-LOCK:** Achten Sie bei der Montage des Cam-Locks auf die richtige Ausgangsposition, bevor Sie den Quickfit einsetzen.

**IT\_BLOCCAGGIO A CAMMA:** Quando si monta il bloccaggio a camma, assicurarsi che la posizione iniziale sia corretta prima di inserire il montaggio rapido di collegamento.

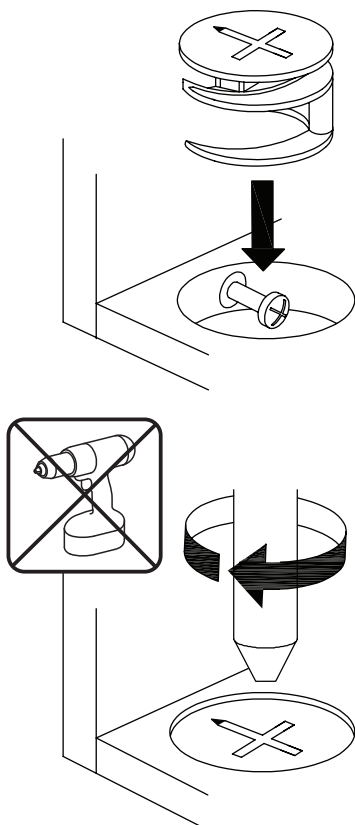

**EN\_Quickfit head** should be in the centre of the cam lock when the two panels are joined.

Cam lock should be inserted before quickfit.

**FR\_**Lorsque les deux panneaux sont assemblés, la tête du raccord rapide doit reposer au centre de la serrure batteuse. Il faut insérer la serrure batteuse avant le raccord rapide.

**ES\_**El cabezal del quickfit debe estar en el centro del cierre de la cámara cuando se unan los dos paneles.

Se debe insertar el cierre de la cámara antes que el quickfit.

**DE\_**Der Quickfit-Kopf sollte sich in der Mitte des Cam-Locks befinden, wenn die beiden Platten zusammengefügt sind. Der Cam-Lock sollte vor dem Quickfit eingesetzt werden.

**IT\_**La testa del montaggio rapido deve trovarsi al centro del bloccaggio a camma quando i due pannelli sono uniti.

Il Bloccaggio a Camma deve essere inserito prima del montaggio rapido.

**EN\_**Turn cam lock clockwise to tighten.

**FR\_**Faites tourner la serrure batteuse dans le sens des aiguilles d'une montre pour la resserrer.

**ES\_**Gire el cierre de la cámara en sentido horario para apretarlo.

**DE\_**Drehen Sie den Cam-Lock im Uhrzeigersinn, um ihn festzuziehen.

**IT\_**Ruotare il bloccaggio a camma in senso orario per stringere.

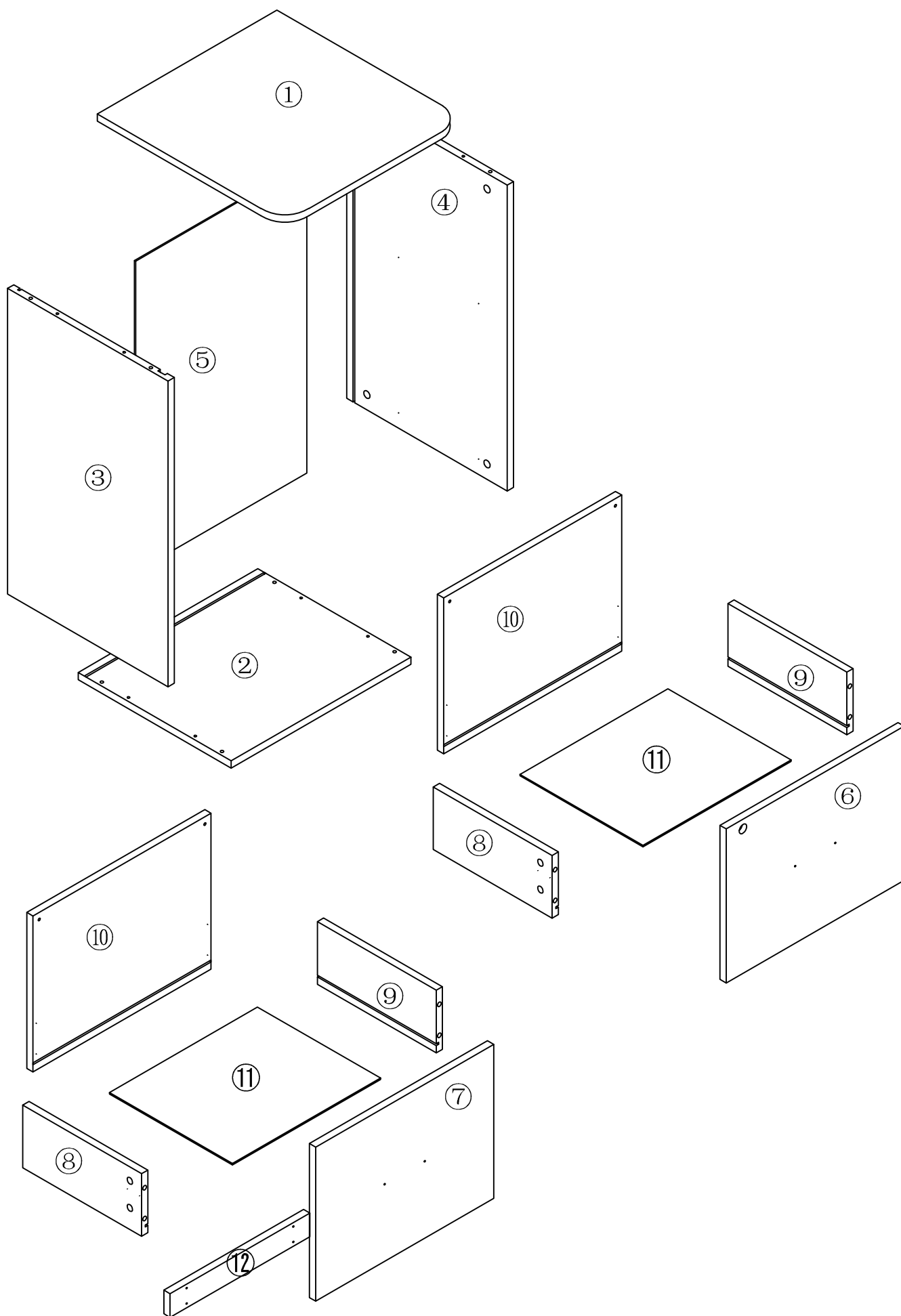

**A** x16  
+1(spare)

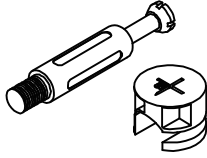

**B** x08  
Φ8\*40  
+1(spare)

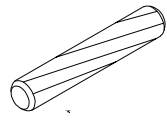

**C** x02

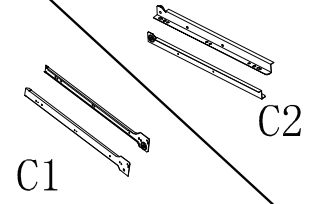

**D** x35  
Φ3.5\*14  
+2(spare)



**E** x08  
Φ3.5\*35  
+1(spare)

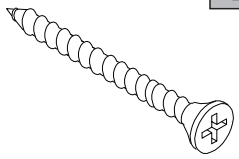

**F** x14  
Φ3\*14  
+1(spare)



**G** x04  
Φ3.5\*25

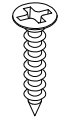

**H** x02



**I** x02

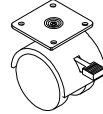

**J** x01

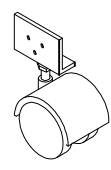

**K** x01

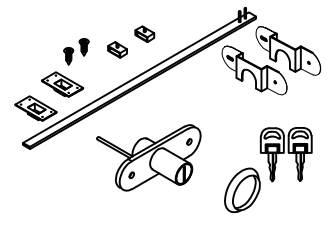

**L** x02  
Φ4\*18

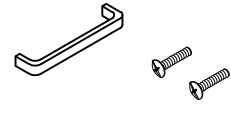

**M** x04

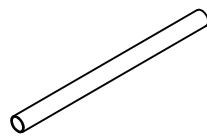

**G** x04  
Φ3\*14

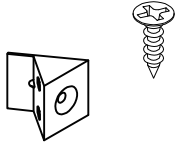

**O** x16  
Φ20

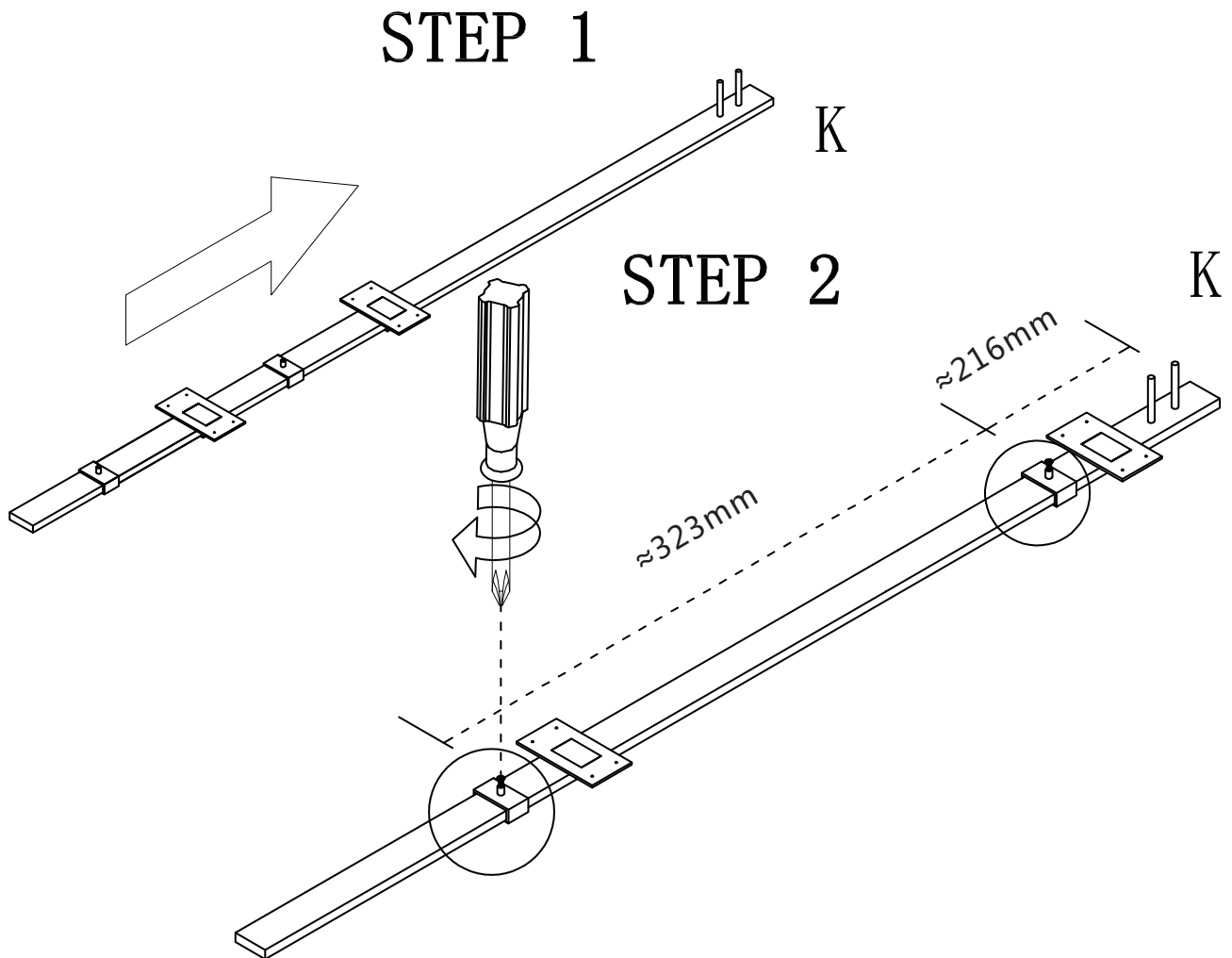

**EN**

1. The location determines whether the lock can be used properly.
2. If you think the lock isn't perfect, you can change the location.
3. For example, move up and down three to five millimeters.

**FR**

1. L'emplacement détermine si la serrure peut être utilisée correctement.
2. Si vous pensez que la serrure n'est pas parfaite, vous pouvez changer l'emplacement.
3. Par exemple, déplacez-vous de haut en bas de trois à cinq millimètres.

**ES**

1. La ubicación determina si la cerradura se puede utilizar correctamente.
2. Si cree que la cerradura no es perfecta, puede cambiar la ubicación.
3. Por ejemplo, mueva hacia arriba y hacia abajo de tres a cinco milímetros.

**DE**

1. Der Standort bestimmt, ob das Schloss ordnungsgemäß verwendet werden kann.
2. Wenn Sie der Meinung sind, dass das Schloss nicht perfekt ist, können Sie den Standort ändern.
3. Bewegen Sie sich beispielsweise drei bis fünf Millimeter nach oben und unten.

**IT**

1. La posizione determina se il lucchetto può essere utilizzato correttamente.
2. Se pensi che la serratura non sia perfetta, puoi cambiare la posizione.
3. Ad esempio, muoviti su e giù da tre a cinque millimetri.

**F** x08

**K** x01

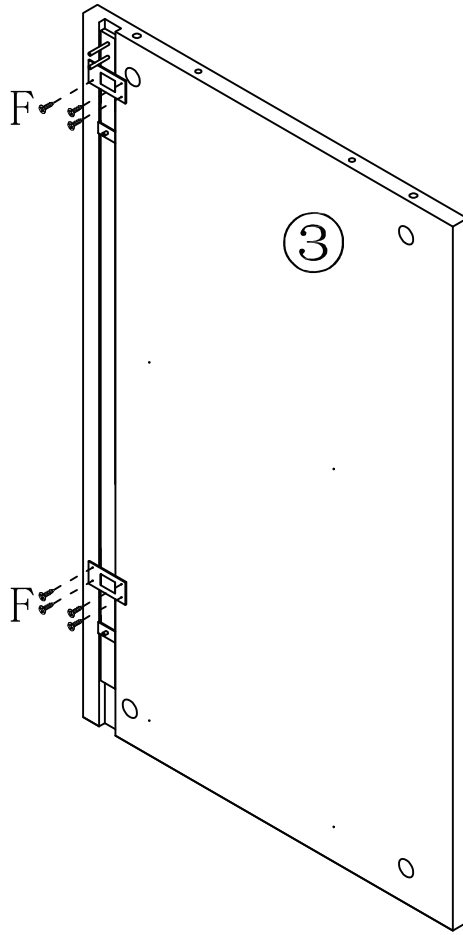

**A** x04

**B** x04

**O** x04

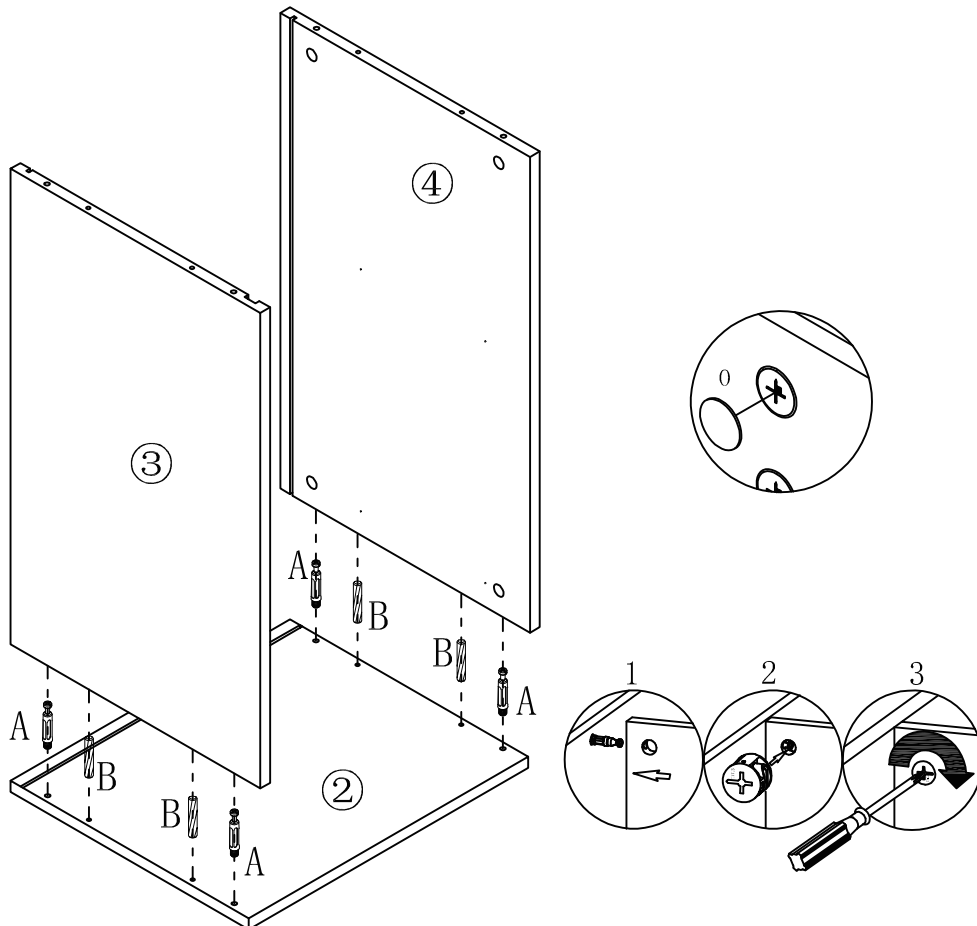

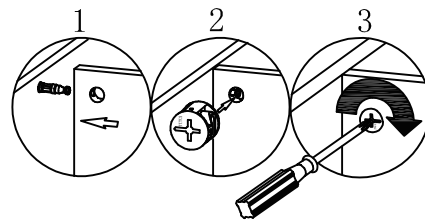
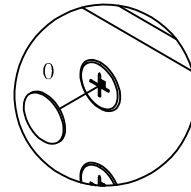
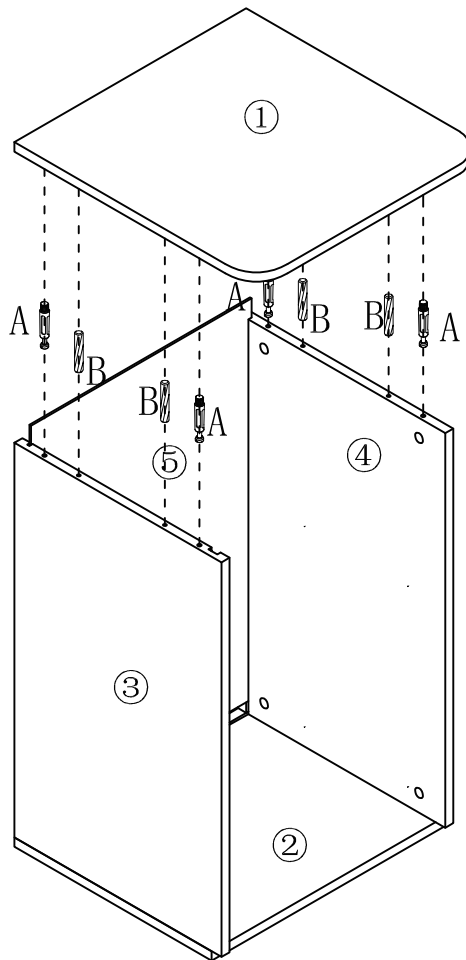
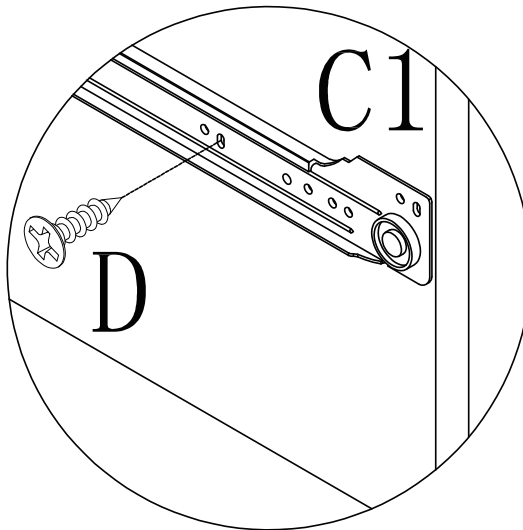
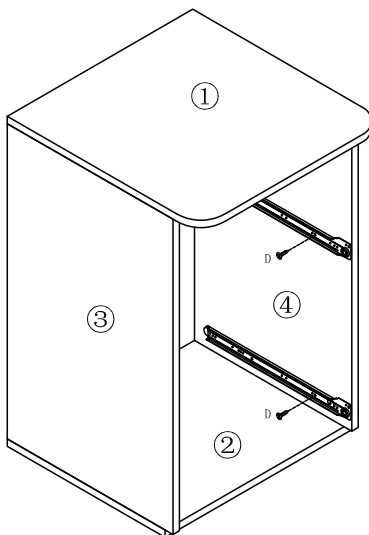
**A** x04**B** x04**O** x04**C1** x02**D** x08

**EN** Please find the exact hole for installation, otherwise it will be misaligned. The screws on the drawer slide must be leveled, otherwise it will affect the smoothness of the drawer.

**FR** Veuillez repérer le trou exact pour l'installation, sinon il sera mal aligné. Les vis de la glissière du tiroir doivent être nivelées, sinon cela affectera la douceur du tiroir.

**ES** Encuentre el orificio exacto para la instalación; de lo contrario, estará desalineado. Los tornillos de la guía del cajón deben estar nivelados, de lo contrario afectará a la suavidad del cajón.

**DE** Bitte benutzen Sie die exakten Bohrungen für die Installation, sonst wird sie falsch ausgerichtet. Die Schrauben an der Schubladenföhrung müssen nivelliert werden, da sie sonst die Leichtigängigkeit der Schublade beeinträchtigen.

**IT** Si prega di individuare il foro corretto per l'installazione, altrimenti sarà disallineato. Le viti della guida del cassetto devono essere livellate, altrimenti la scorrevolezza del cassetto ne risentirà.

**E** x08

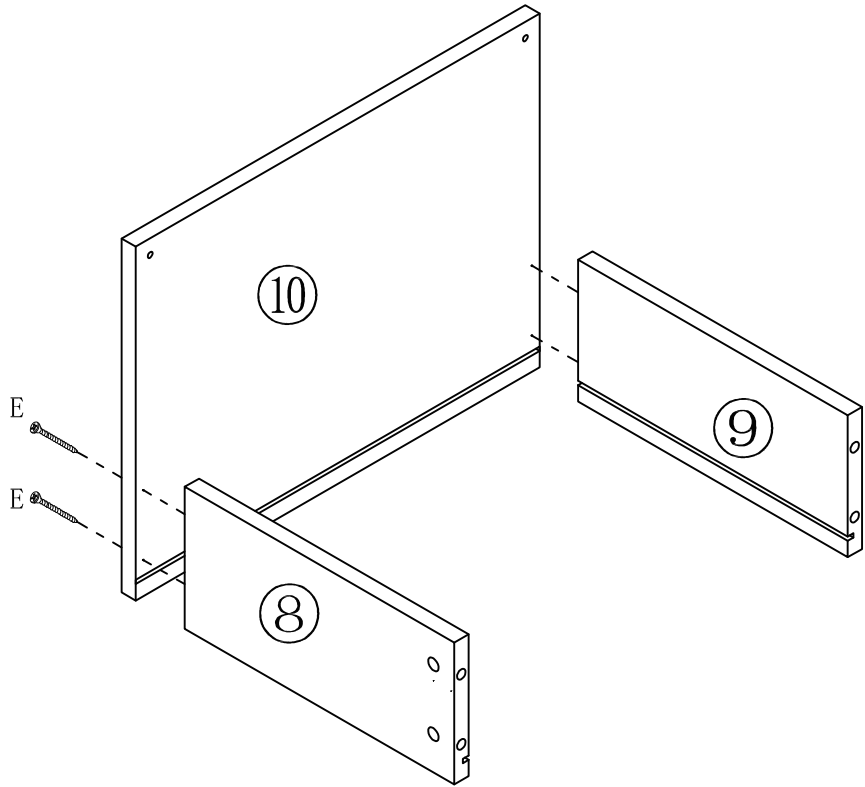

x2

**F** x02

**K** x01

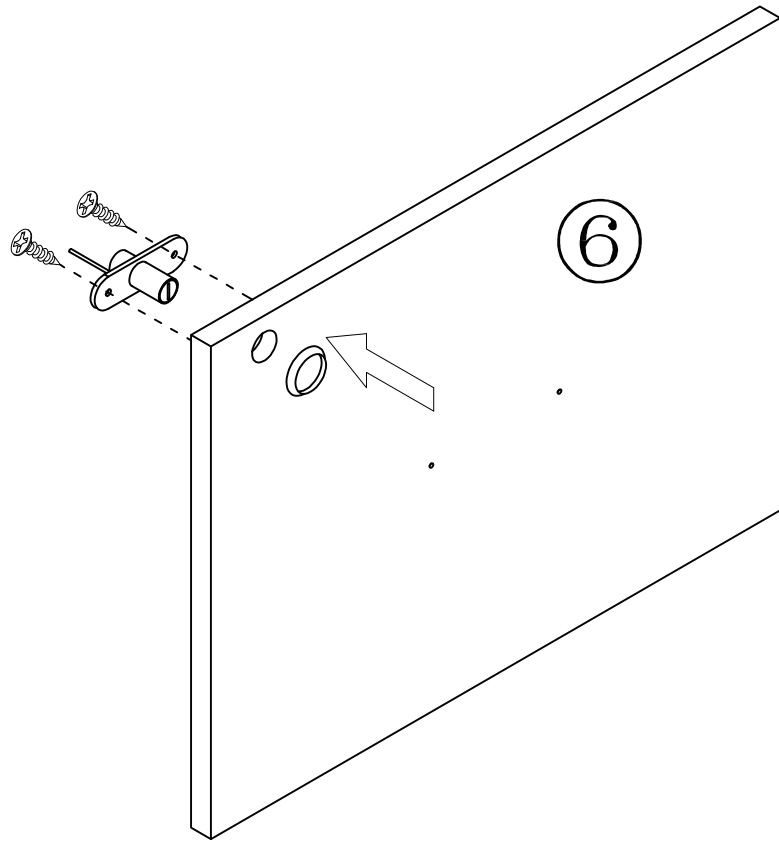



**G** x04

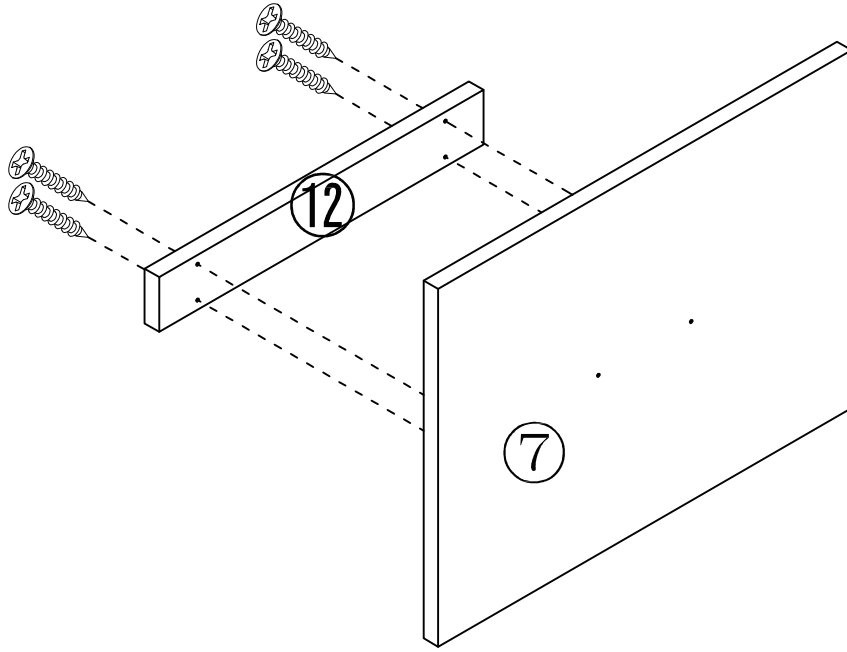

**D** x03

**J** x01

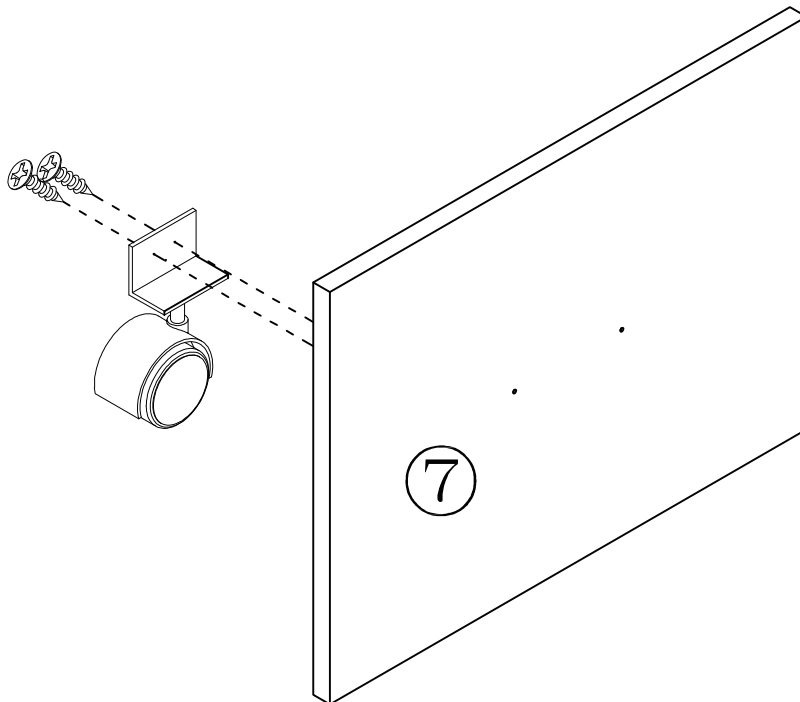

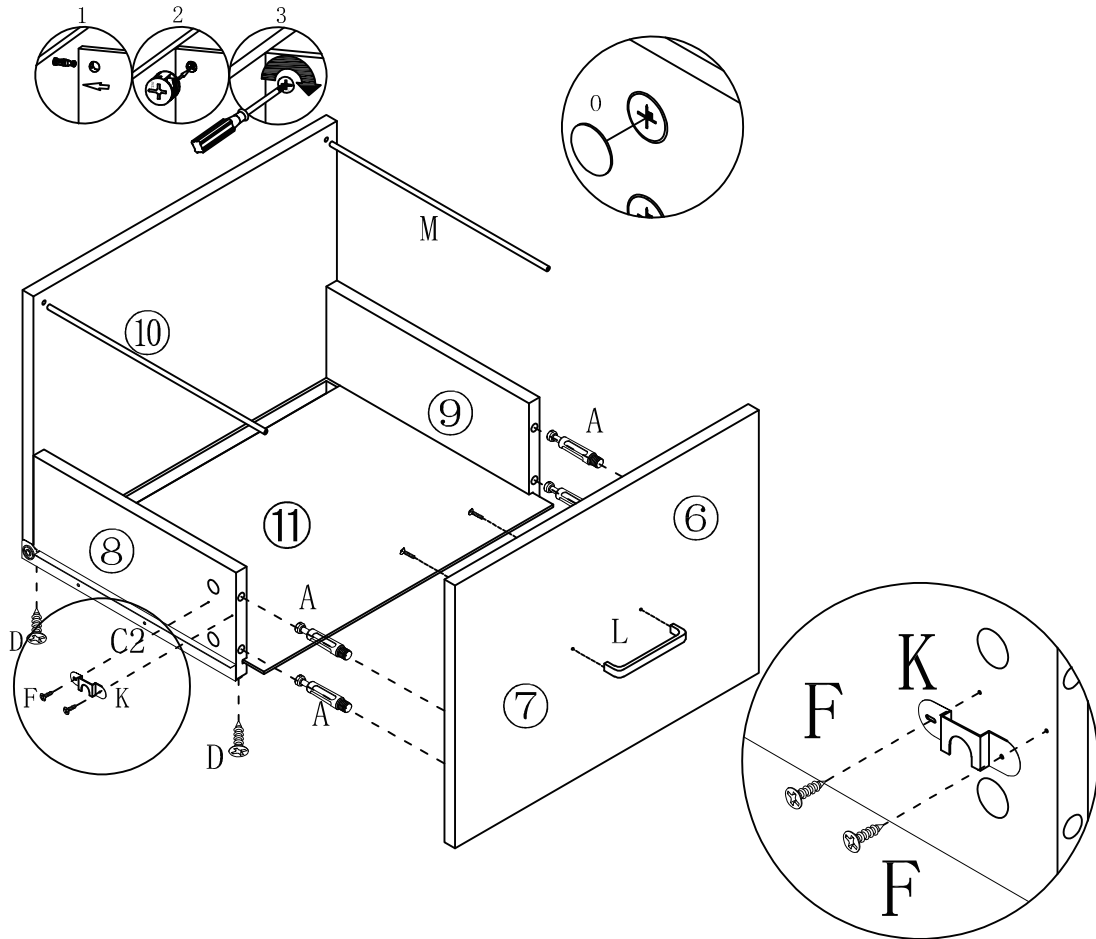
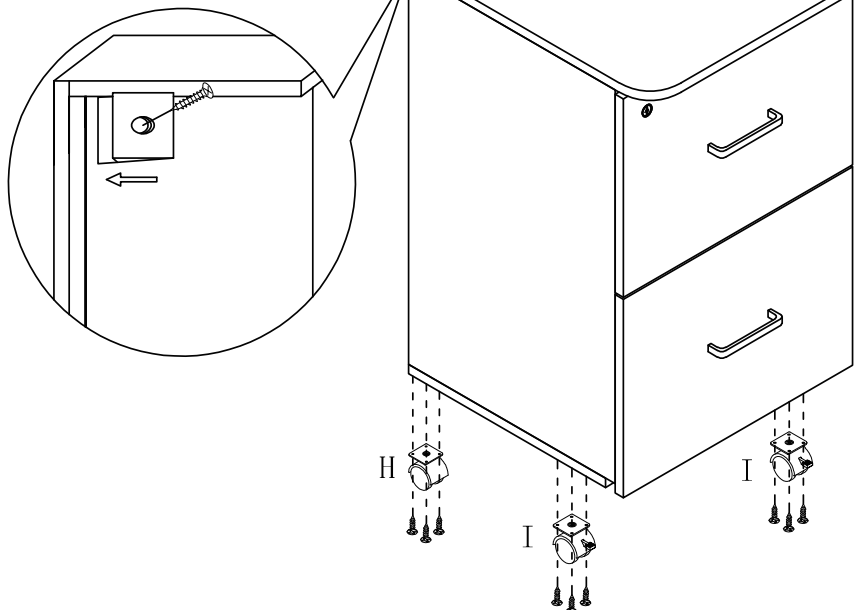
**A** x08**C2** x02**D** x08**F** x04**K** x01**L** x02**M** x04**O** x08**x2****D** x16**H** x02**I** x02

**EN**\_Be careful to push in the board when the both sides slide way been aligned.

**FR**\_Prenez soin d'enfoncer la carte lorsque les deux côtés coulissants sont alignés.

**ES**\_Tenga cuidado al empujar el tablero cuando los ambos lados se hayan alineado.

**DE**\_Achten Sie darauf, dass Sie die Platte einschieben, wenn der Gleitweg auf beiden Seiten ausgerichtet ist.

**IT**\_Prestare attenzione quando si spinge l'asse se entrambi i lati sono allineati.

