

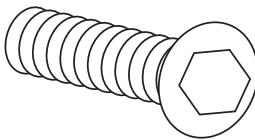

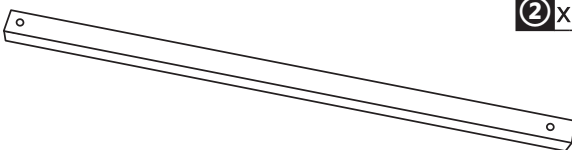

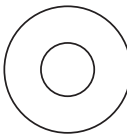
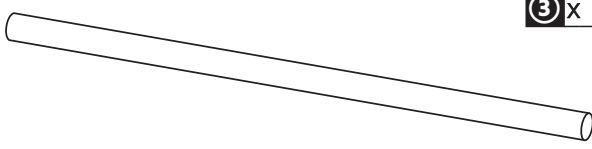
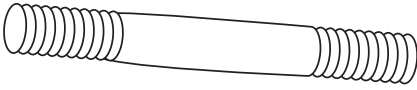
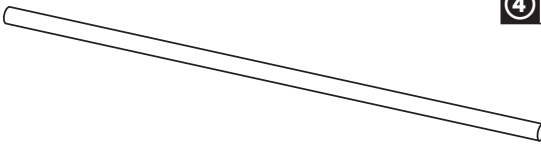
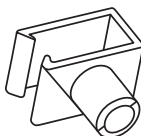
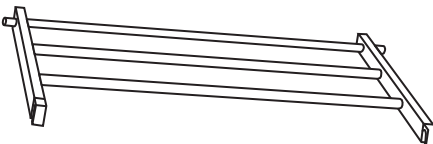

	① x 4		⑧ x 4
	② x 4		⑨ x 2
	③ x 1		⑩ x 2
	④ x 2		⑪ x 2
	⑤ x 1		⑫ x 8
	⑥ x 1		⑬ x 4
	⑦ x 2		⑭ x 4
			⑮ x 1

01

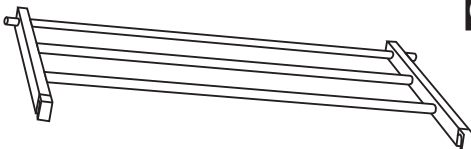
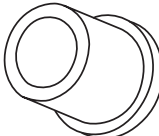

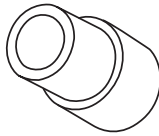
① x 1

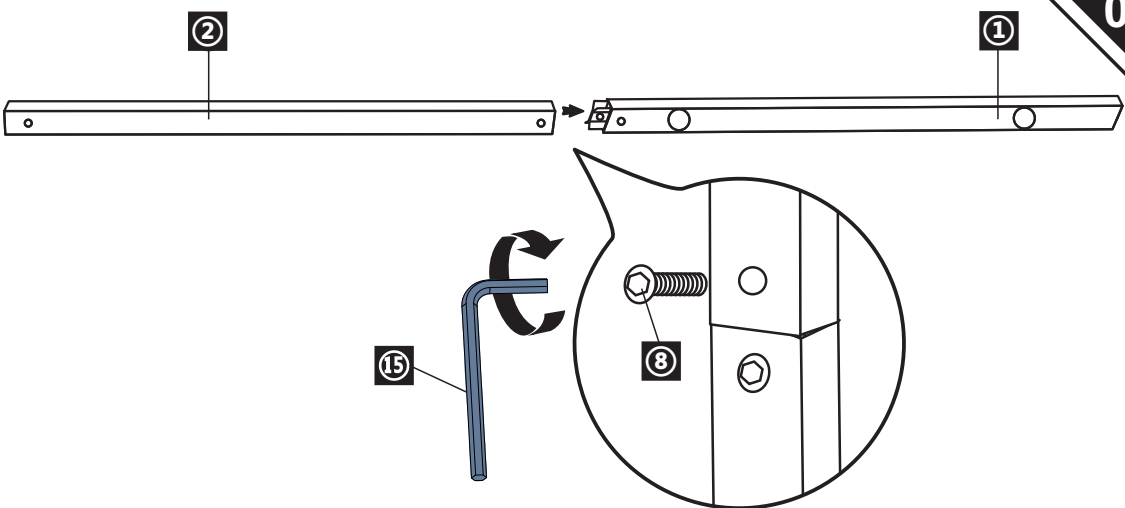

② x 1



⑧ x 1



⑮ x 1



x4

UK: Connect tube ① and tube ② with screw ⑧ as shown below.
 DE: Verbinden Sie Rohr ① und Rohr ② mit der Schraube ⑧ wie unten gezeigt.
 IT: Collegare il tubo ① e il tubo ② con la vite ⑧ come mostrato di seguito.

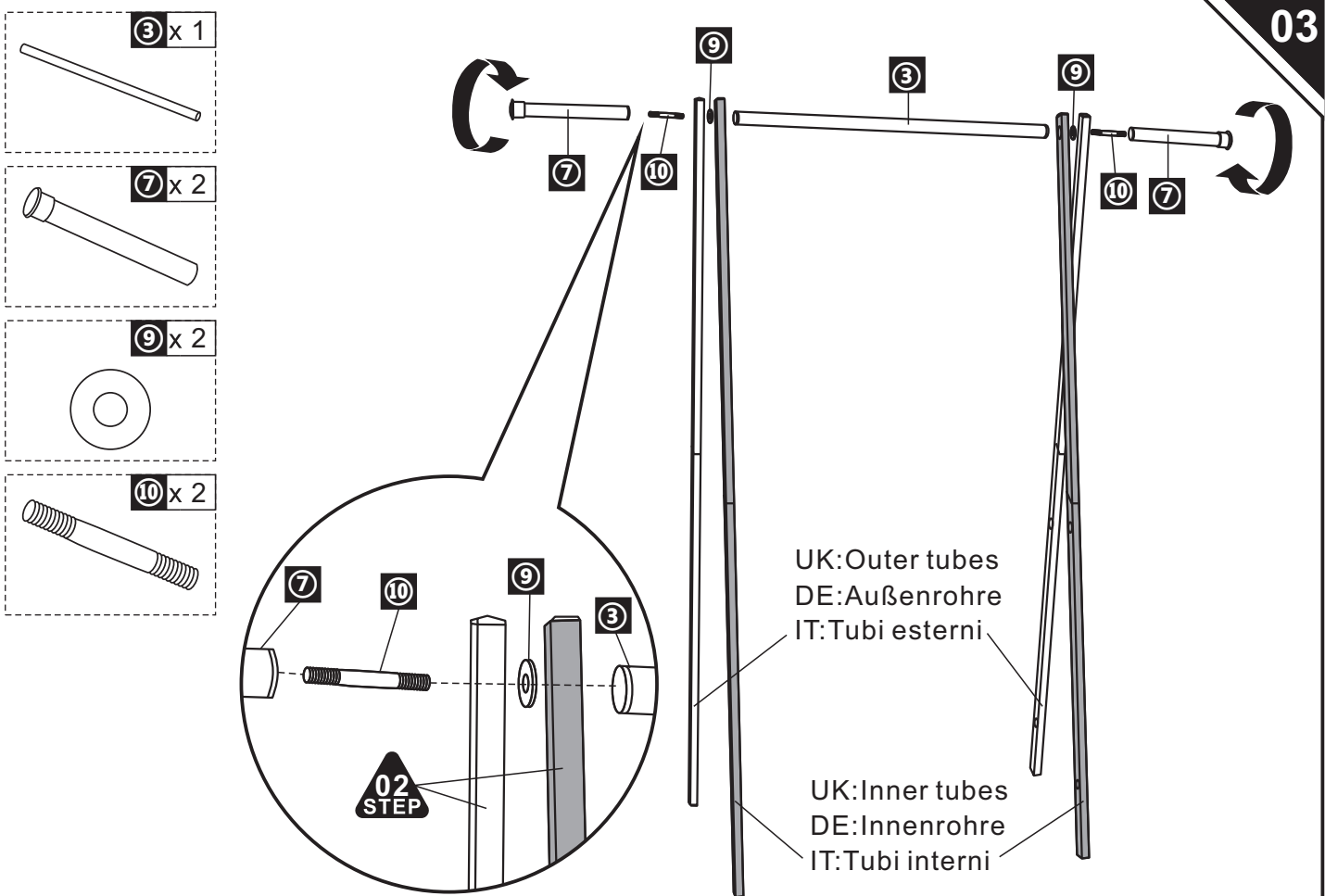
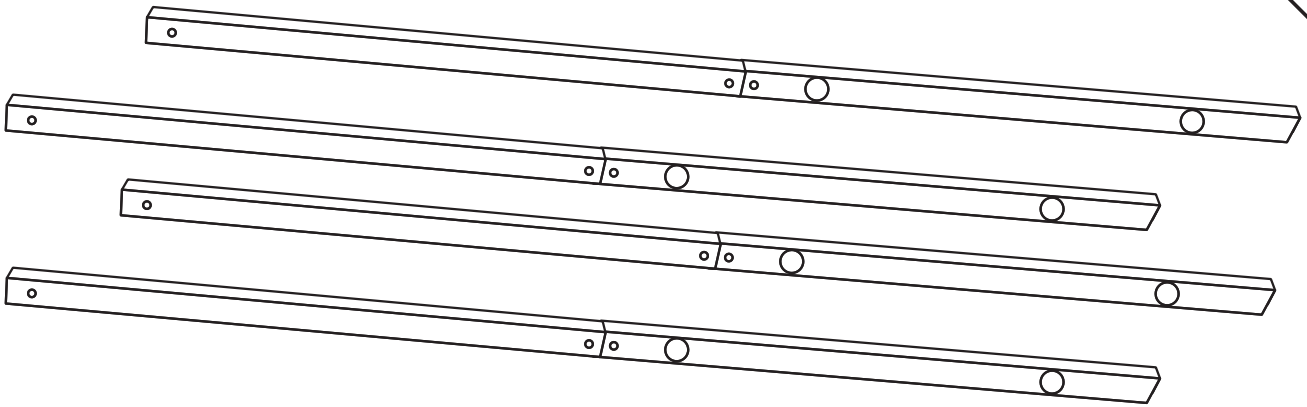

UK: Put ⑩ into the upper hole of tube ②. Put ⑨ between tube ③ and tube ⑦, then tighten tube ③ and tube ⑦ with your strength (another side is with the same way to fix). After finishing aboved steps, adjust two inner tubes to same direction. And two outer tubes to the opposite direction.

DE: Setzen Sie ⑩ in das obere Loch des Rohrs ② ein. Setzen Sie ⑨ zwischen Rohr ③ und Rohr ⑦, dann ziehen Sie Rohr ③ und Rohr ⑦ mit Ihrer Stärke (eine andere Seite ist auf die gleiche Weise zu befestigen) an. Stellen Sie nach Abschluss der obigen Schritte zwei Innenrohre auf die gleiche Richtung ein. Und stellen Sie zwei Außenrohre zur gegenüberliegenden Richtung ein.

IT: Inserire ⑩ nel foro superiore del tubo ②. Mettere ⑨ tra tubo ③ e tubo ⑦, quindi fissare con il tubo ③ e il tubo ⑦ (fissare allo stesso modo il lato opposto). Dopo aver concluso gli step sopra indicati, regolare i due tubi interni nella stesso direzione. E due tubi esterni in direzione opposta.

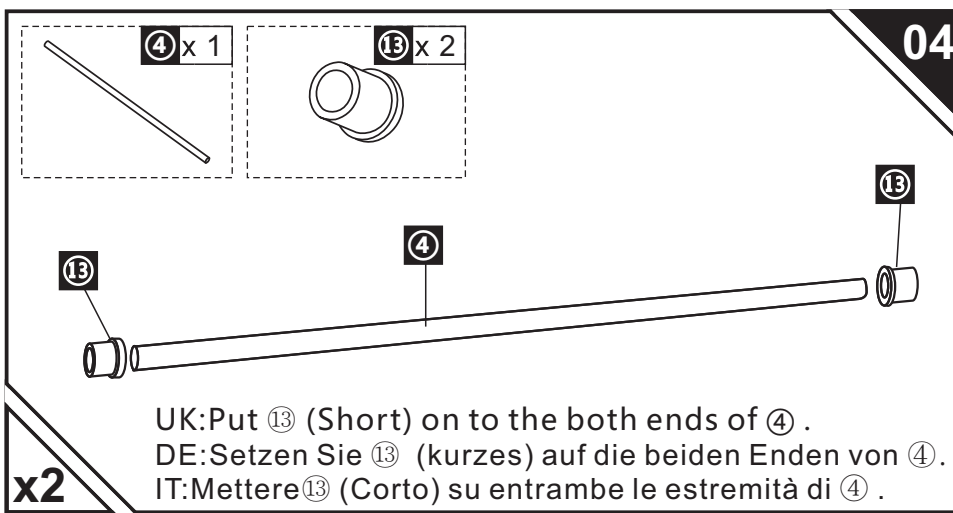

UK: Put 13 (Short) on to the both ends of 4 .
 DE: Setzen Sie 13 (kurzes) auf die beiden Enden von 4 .
 IT: Mettere 13 (Corto) su entrambe le estremità di 4 .

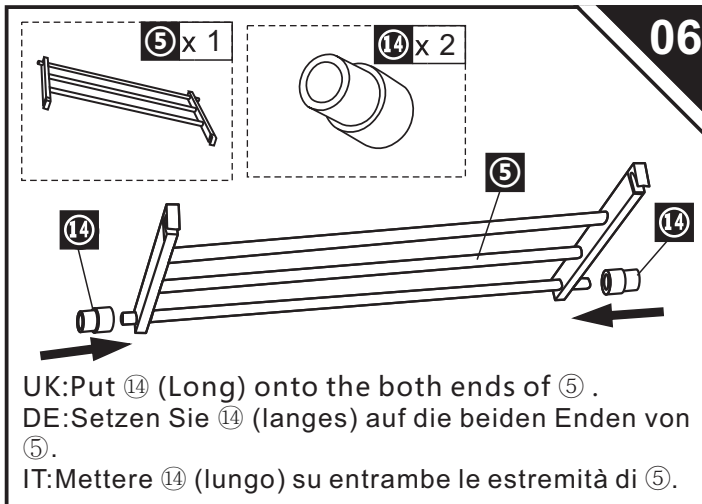
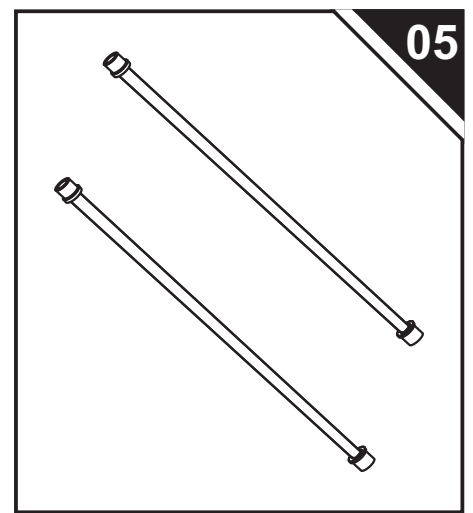

UK: Put 14 (Long) onto the both ends of 5 .
 DE: Setzen Sie 14 (langes) auf die beiden Enden von 5 .
 IT: Mettere 14 (lungo) su entrambe le estremità di 5 .

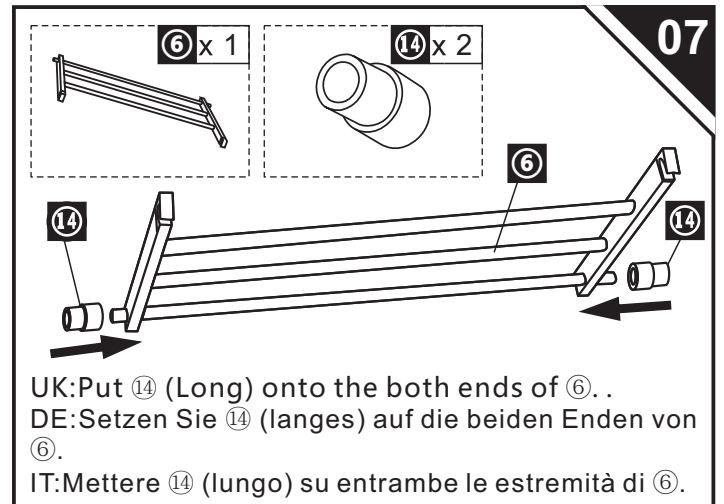

UK: Put 14 (Long) onto the both ends of 6 . .
 DE: Setzen Sie 14 (langes) auf die beiden Enden von 6 .
 IT: Mettere 14 (lungo) su entrambe le estremità di 6 .

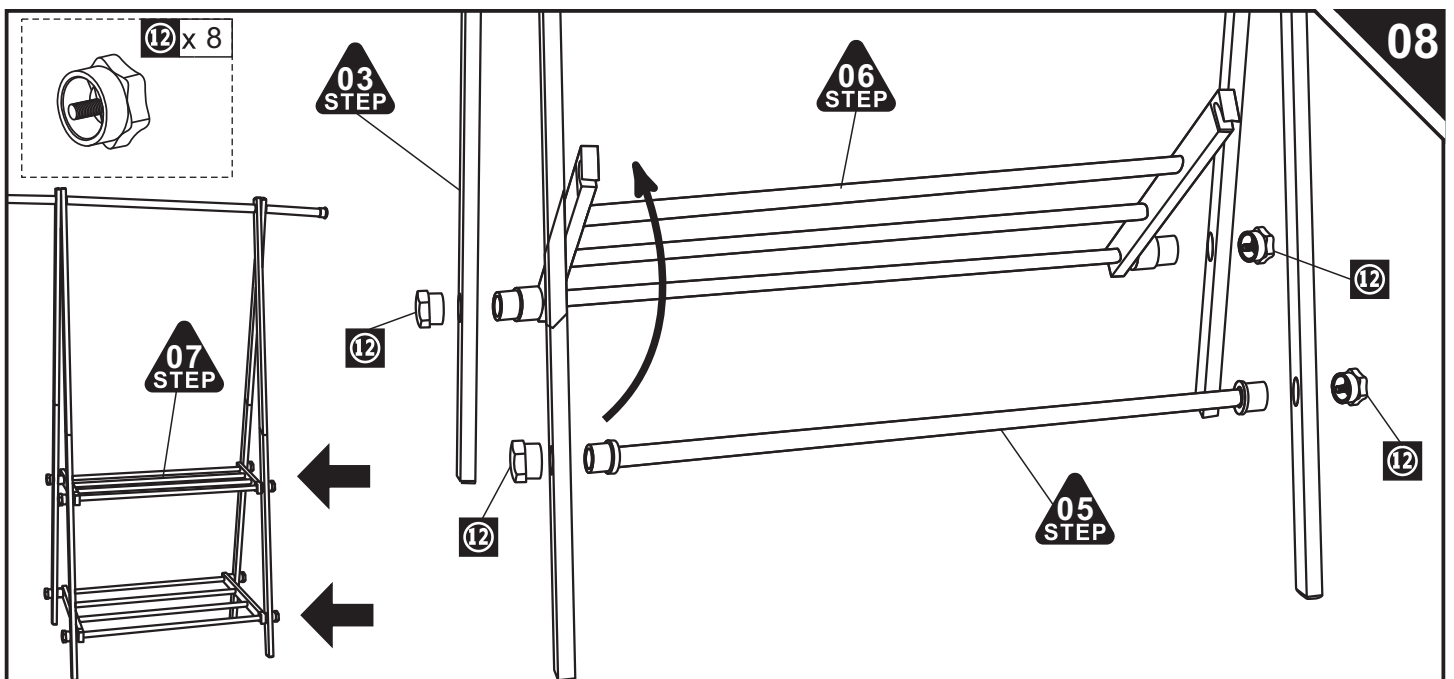

UK: Fix the part which is already finished in step three into the big hole at the bottom of two outer tubes , and tighten them with 12 lightly. After 5 and 6 are both finished fixing toally, tighten 12 with your strength tightly.

DE: Befestigen Sie den Teil, der bereits in Schritt drei fertig ist, in dem großen Loch am Boden zweier Außenrohre und ziehen Sie sie mit 12 leicht an. Nachdem 5 und 6 beide vollständig fixiert sind, ziehen Sie 12 mit Ihrer Kraft fest an.

IT: Fissare la parte che è già terminata nel passaggio tre nel grande foro alla base di due tubi esterni e serrarli con 12 delicatamente. Dopo che 5 e 6 sono fissate in sicurezza, hanno terminato il fissaggio a livello, fissare anche 12.

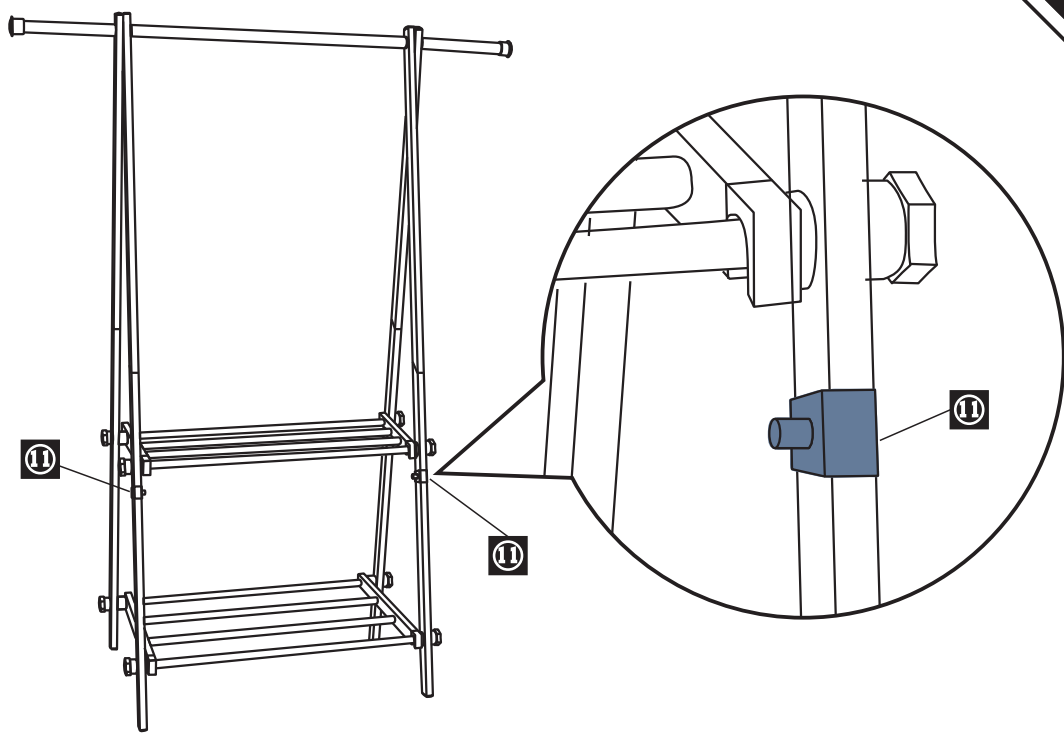
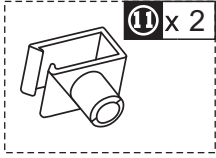

UK: Fix ① on the suitable place of two inner tubes, you can adjust the place of ① as you need when you fold the rack.

DE: Befestigen Sie ① an der geeigneten Stelle von zwei Innenrohren. Sie können die Stelle nach ① Bedarf einstellen, wenn Sie das Gestell zusammenklappen.

IT: Fissare ① nell'incavo adatto le due camere d'aria, è possibile regolarle ① come necessario quando si piega il supporto

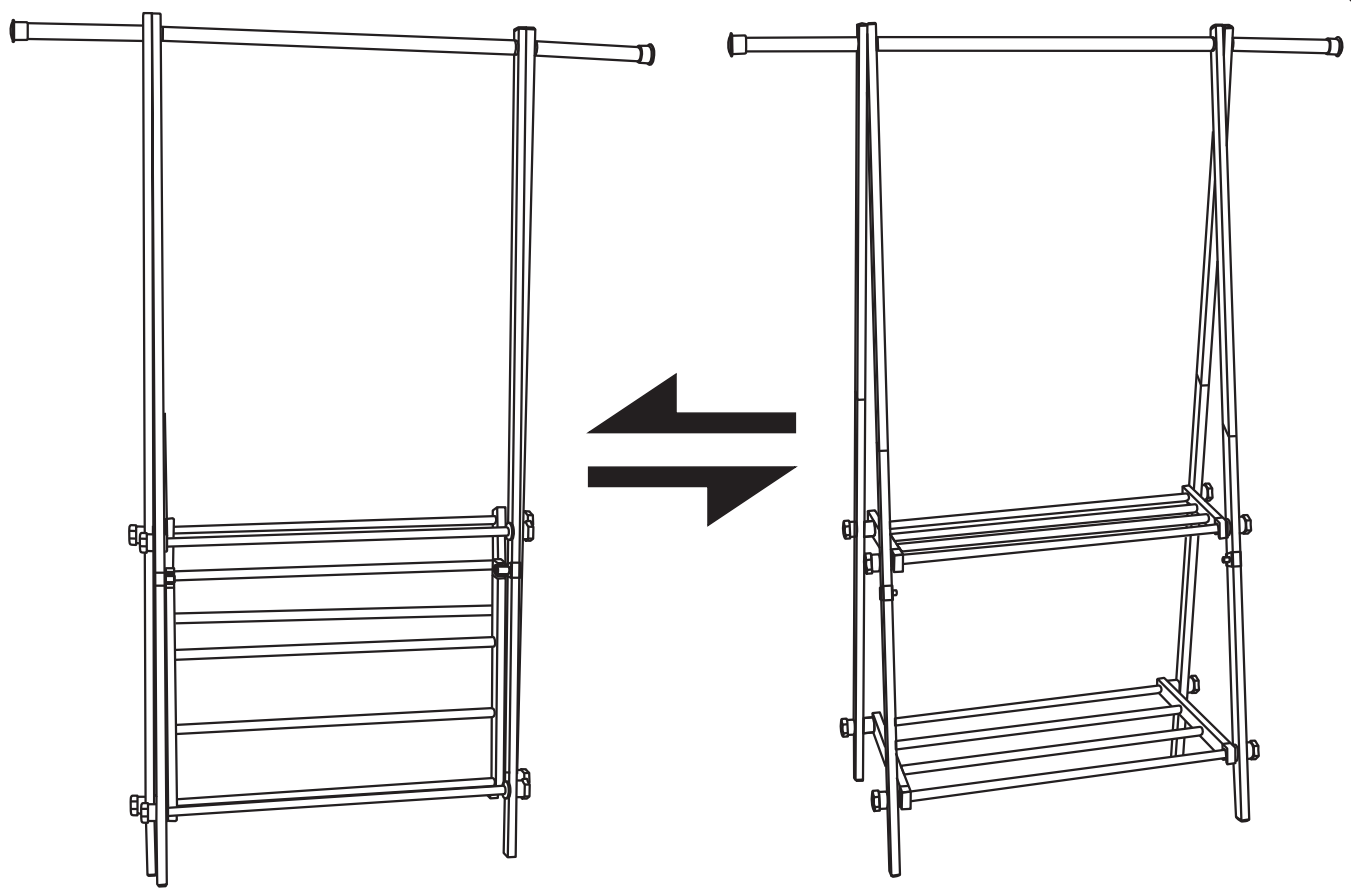

US



001-877-644-9366
customerservice@aosom.com

CA



001-855-537-6088
customerservice@aosom.ca

UK



0044-800-240-4004
enquiries@mhstar.co.uk

DE



0049-(0)40-88307530
service@aosom.de

FR



0033-1-84166106
contact@aosom.fr

ES



0034-931294512
atencioncliente@aosom.es

IT



0039-0249471447
clienti@aosom.it