

833-421

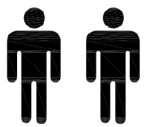

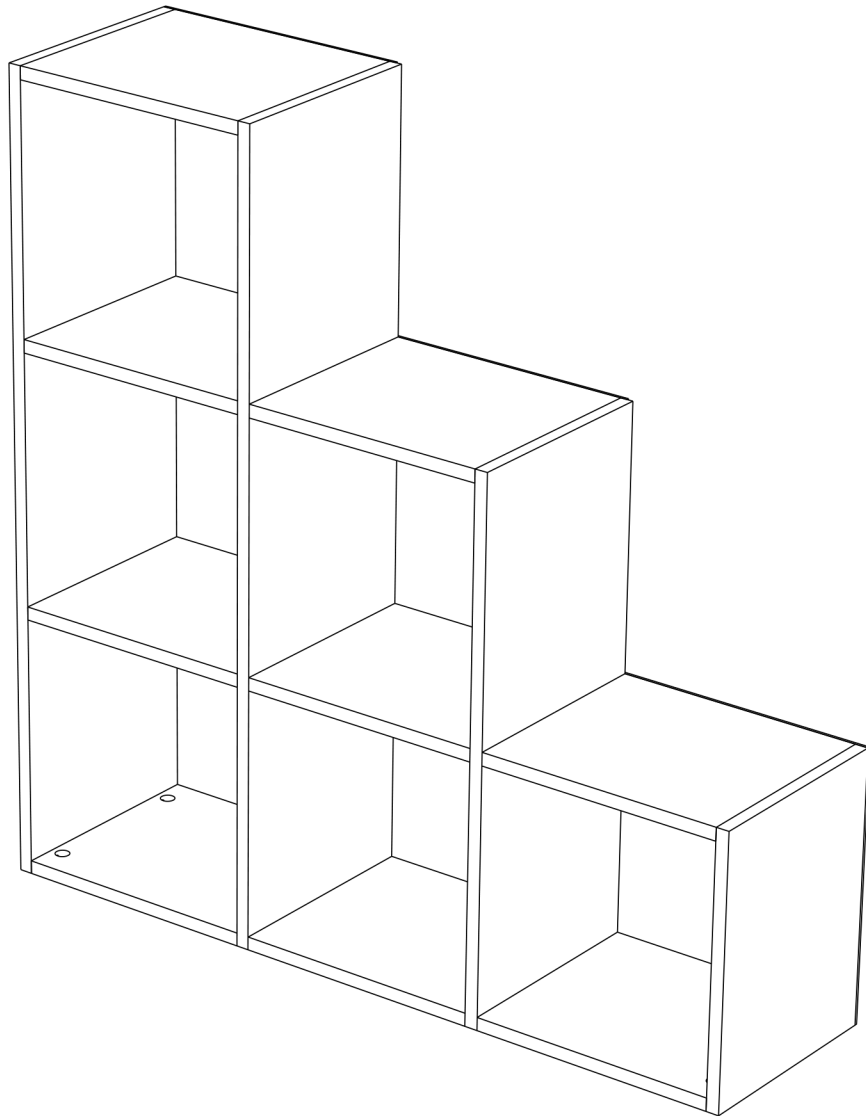

2 PERS.

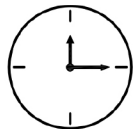

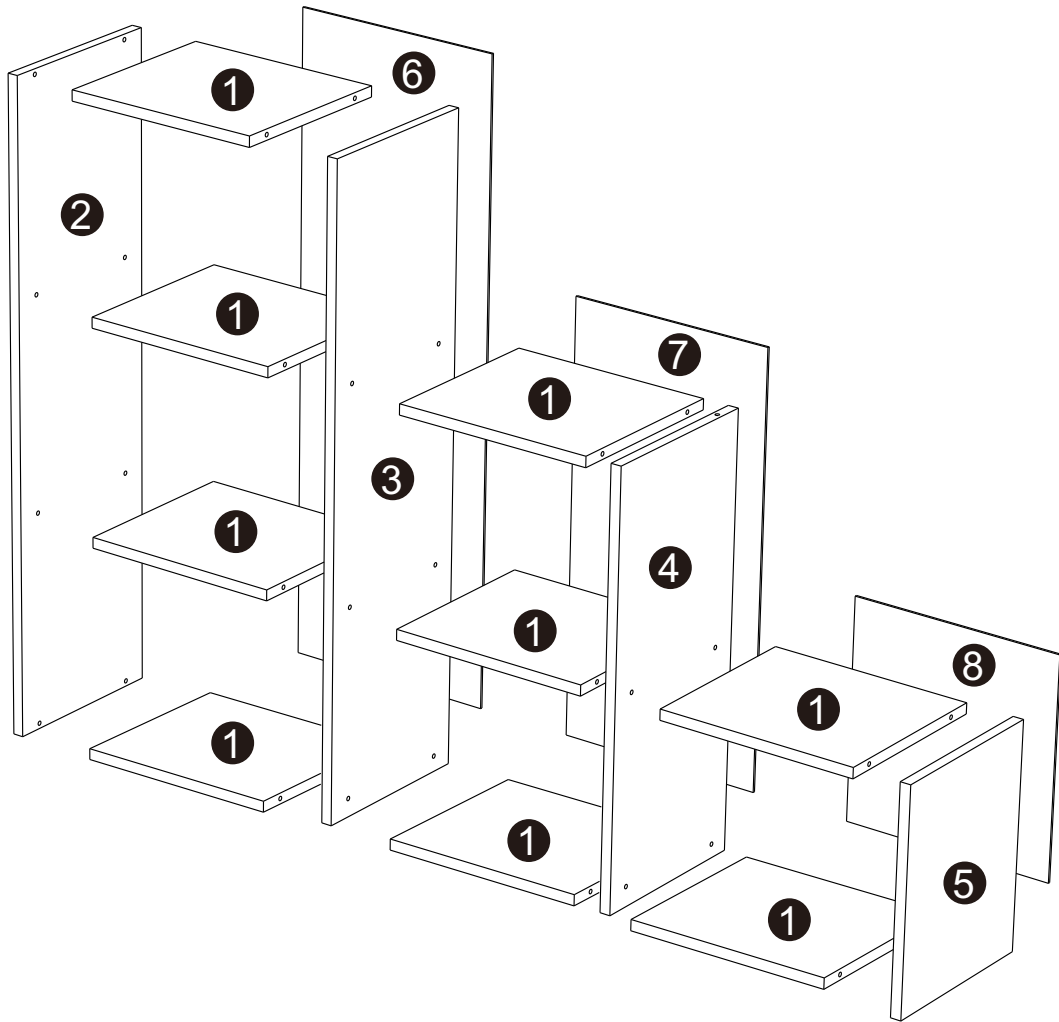
60 MIN

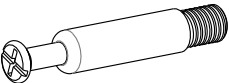

A	x39
	

B	x39
	

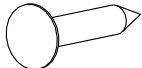
C	x57
	

1

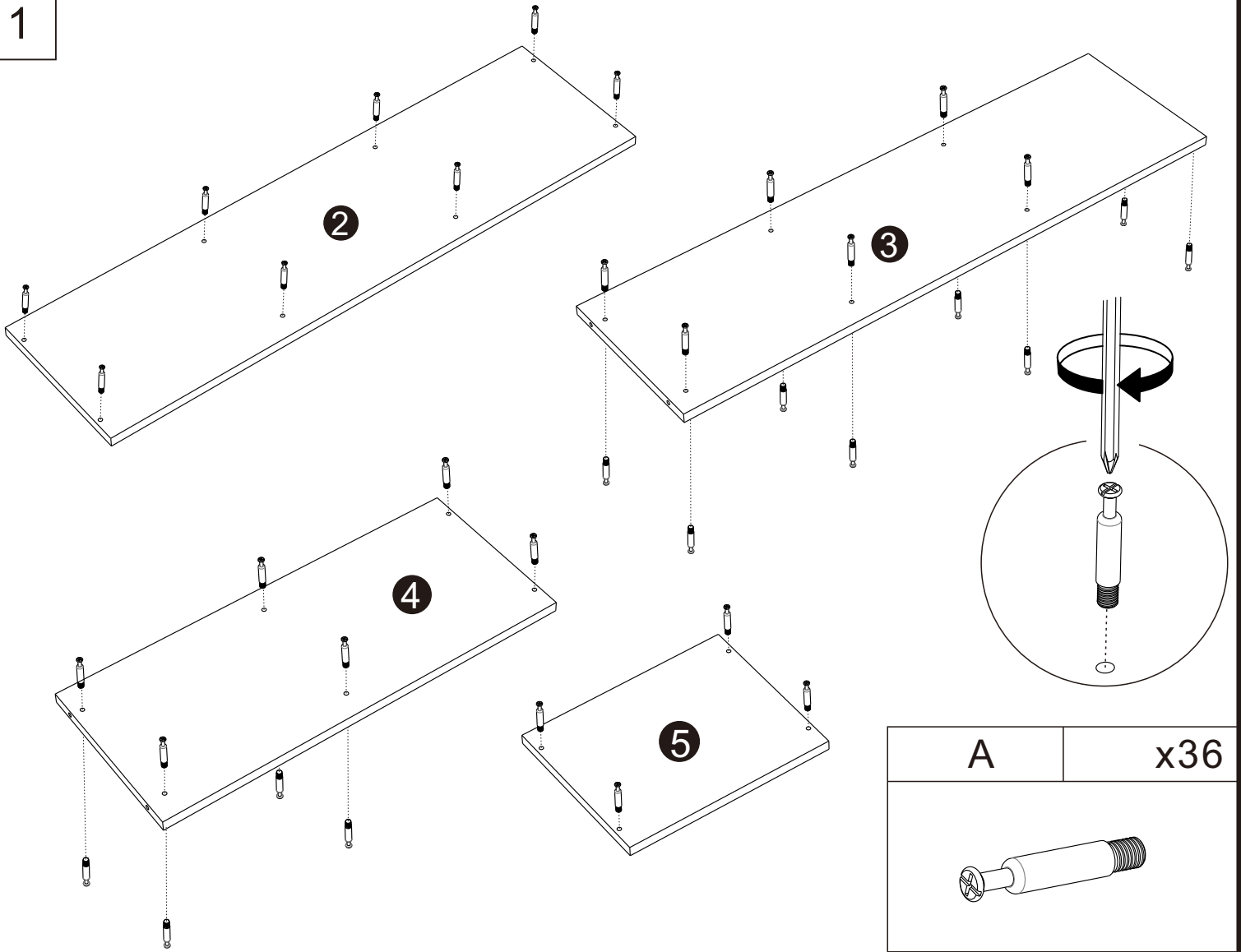

2

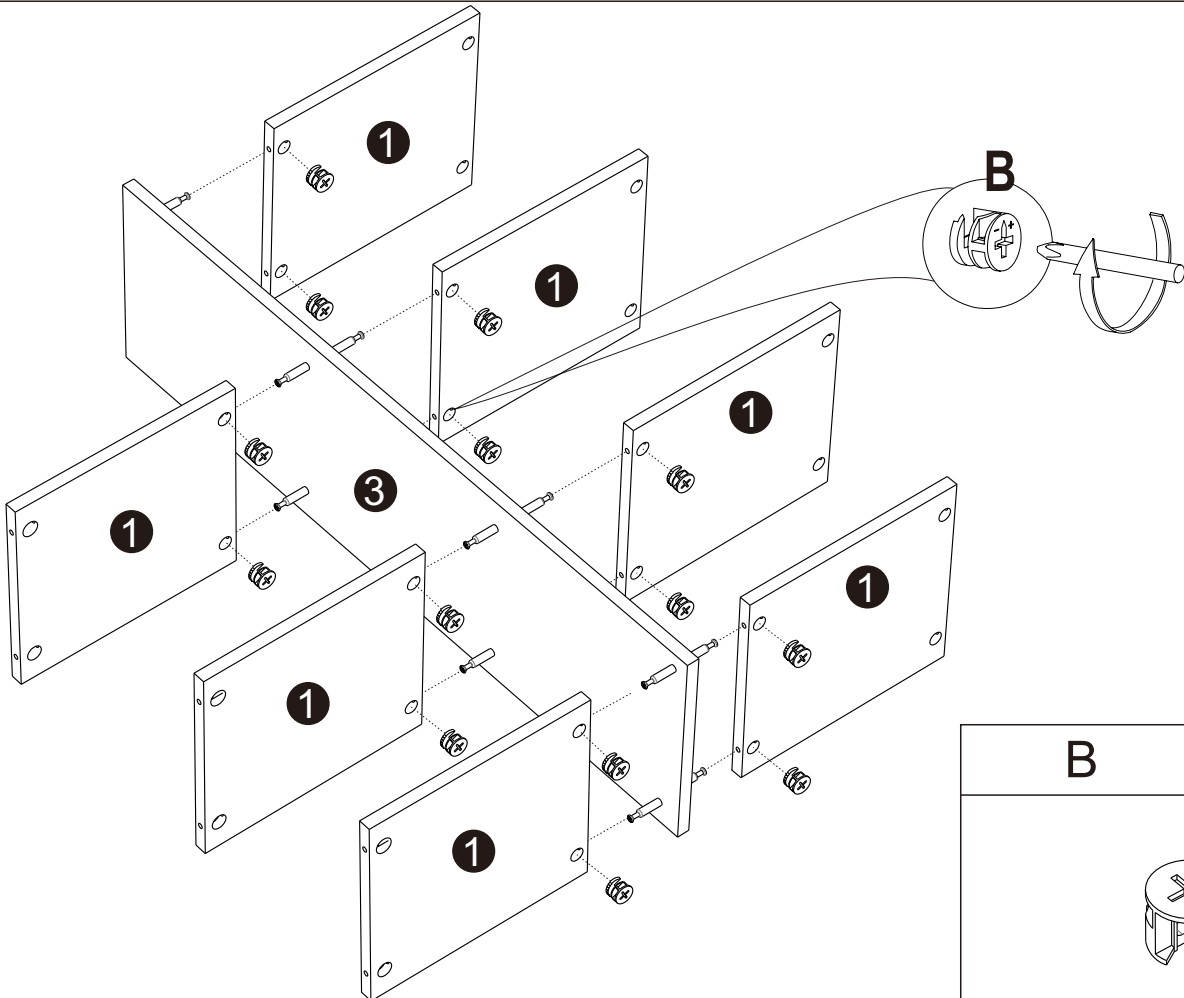

3

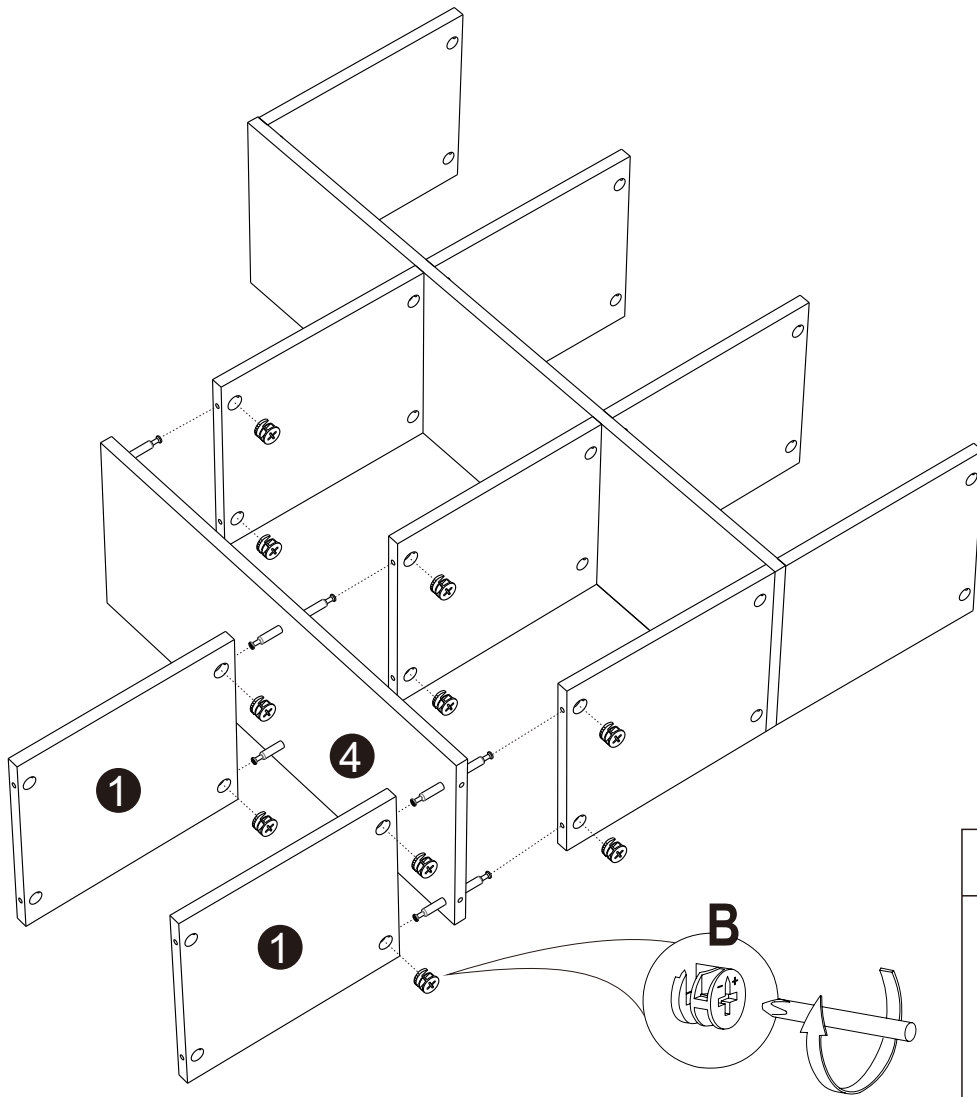

B	x10

4

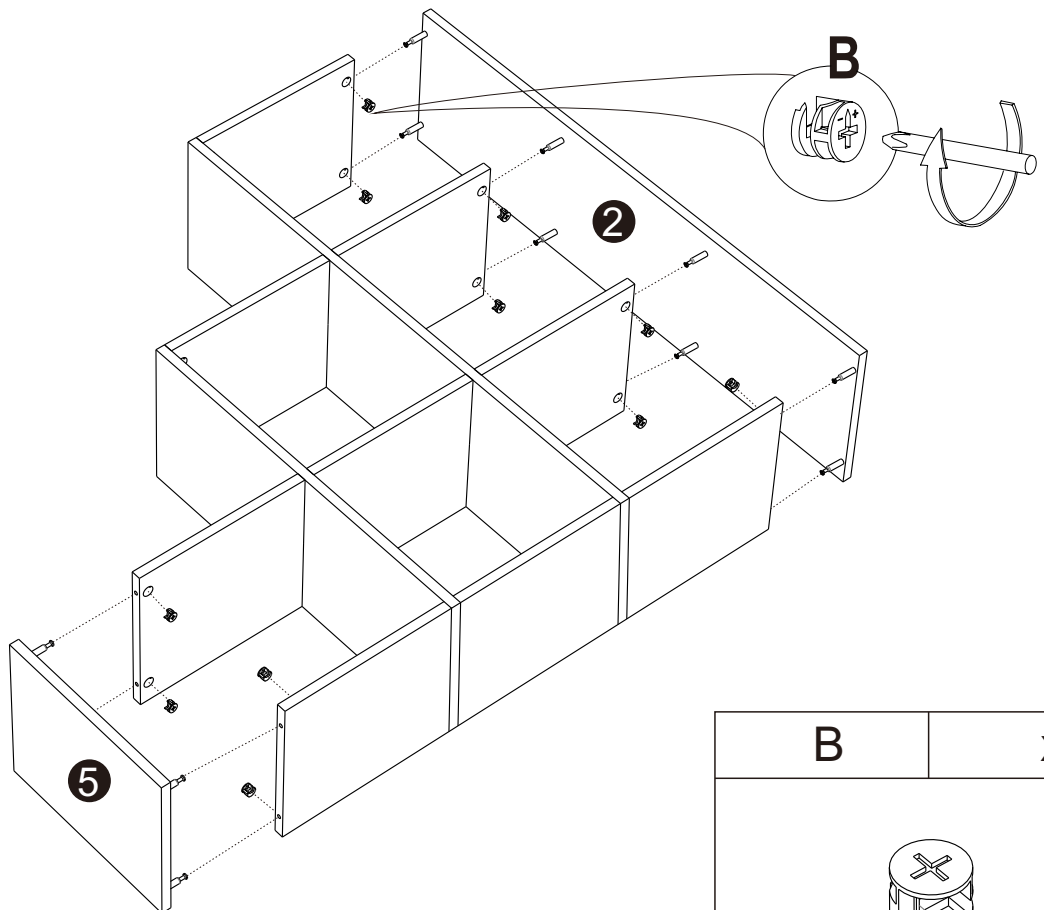

B	x12

5

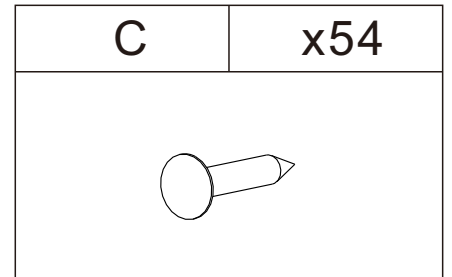
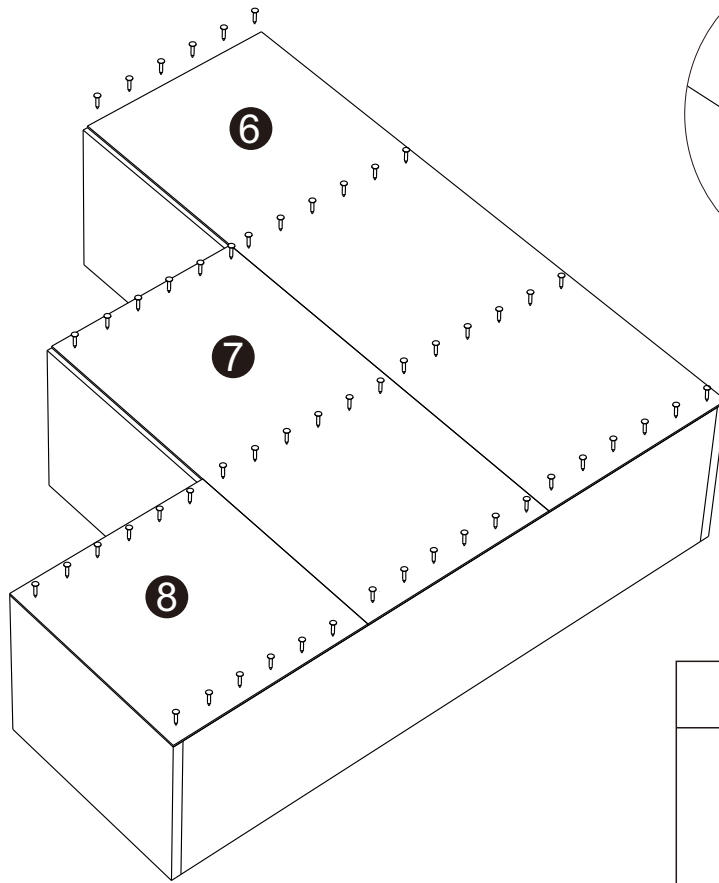

6

