

833-423

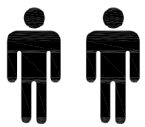

2 PERS.

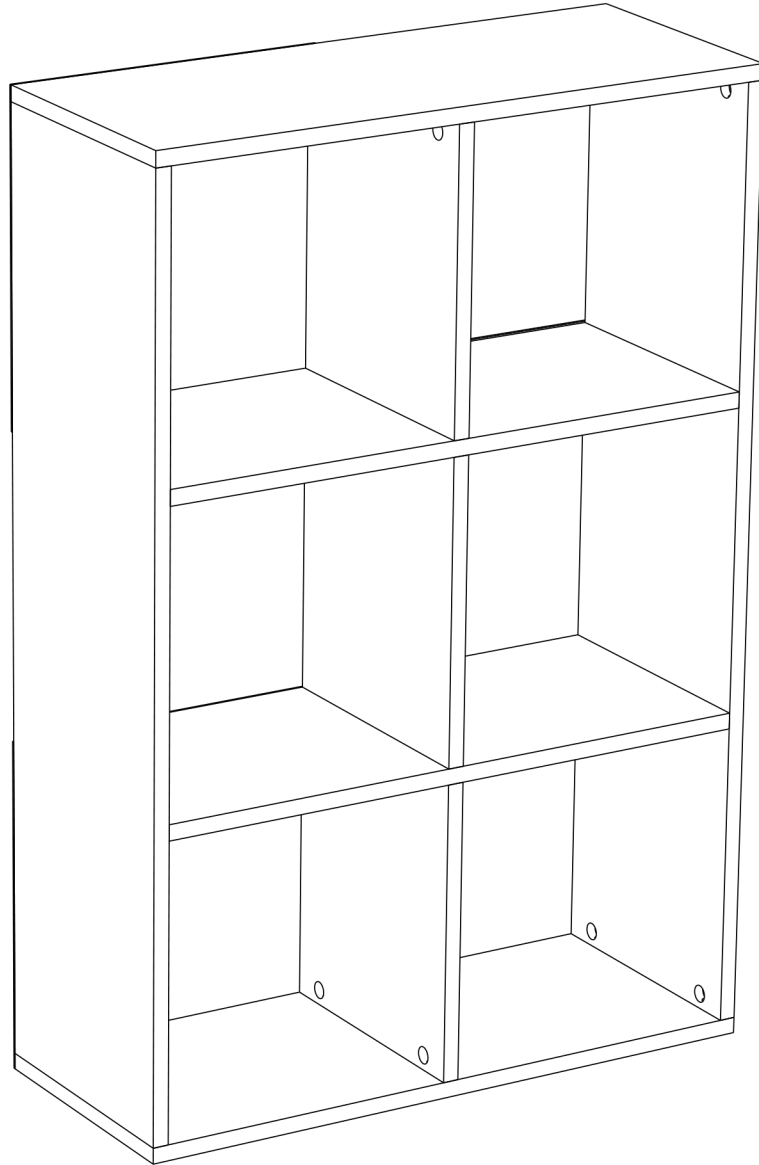
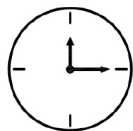

60 MIN

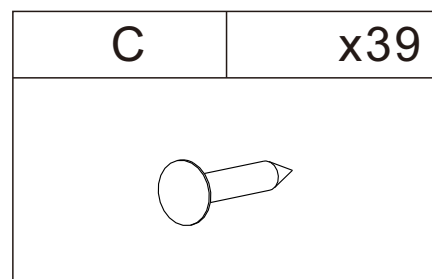
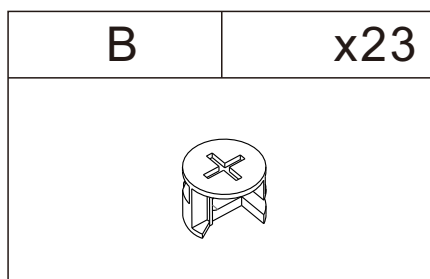
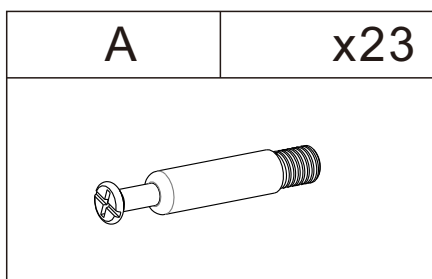
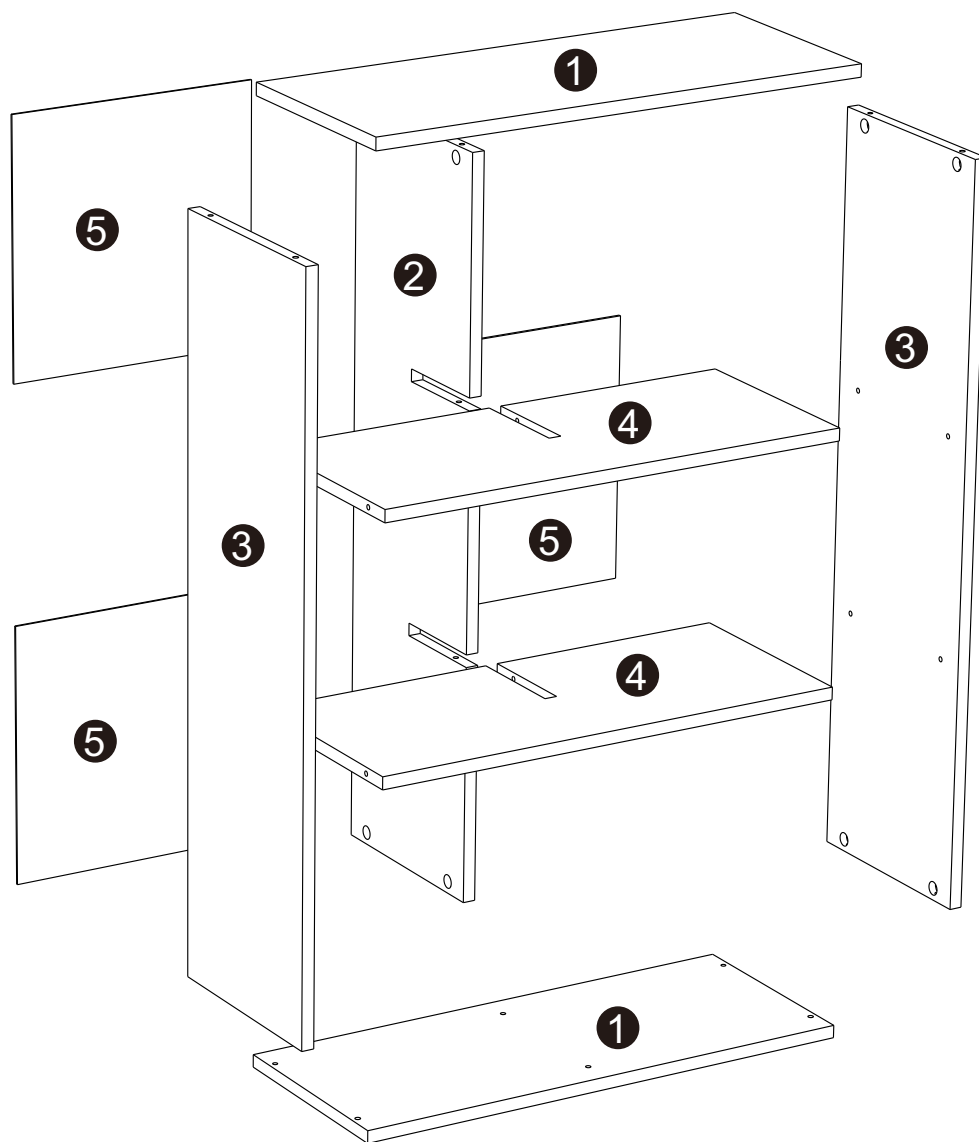

1

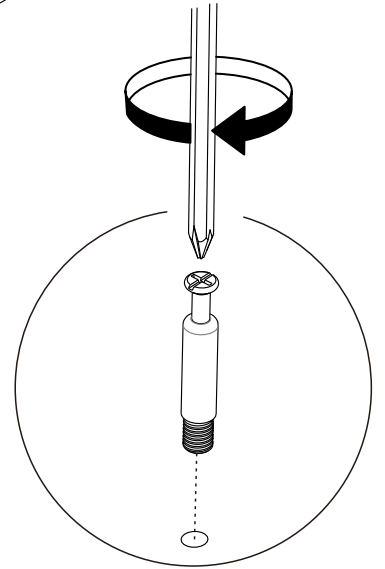
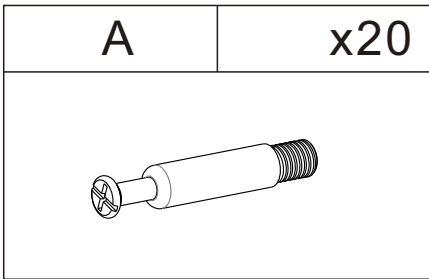
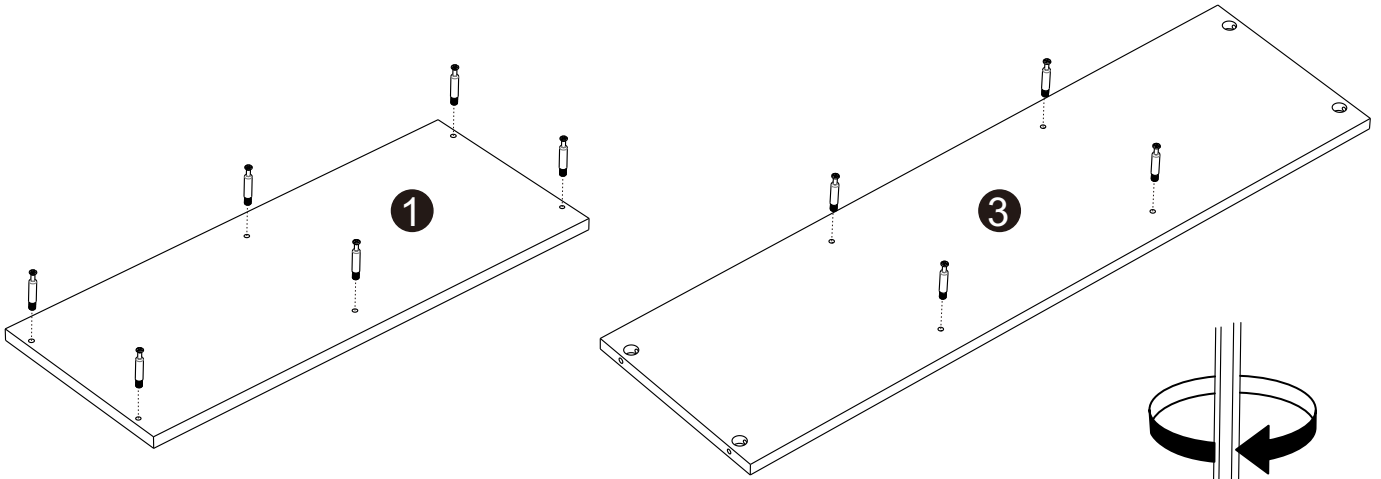

2

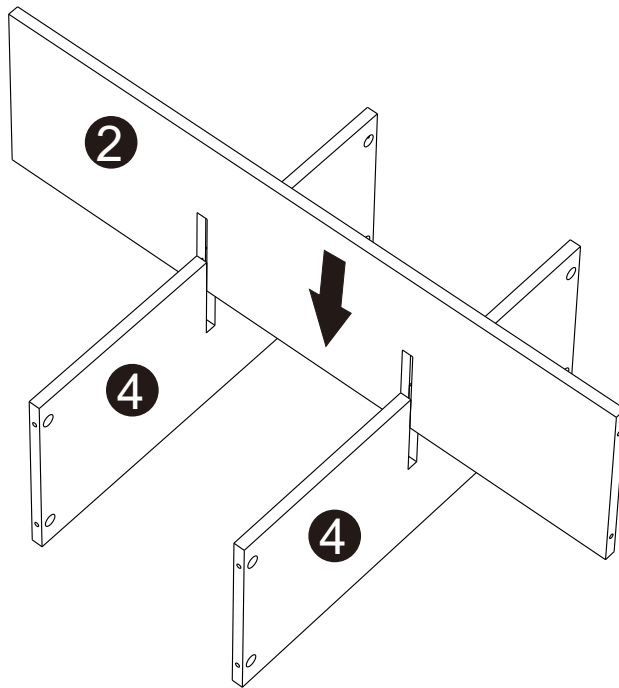

3

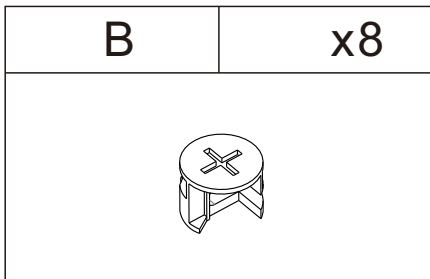
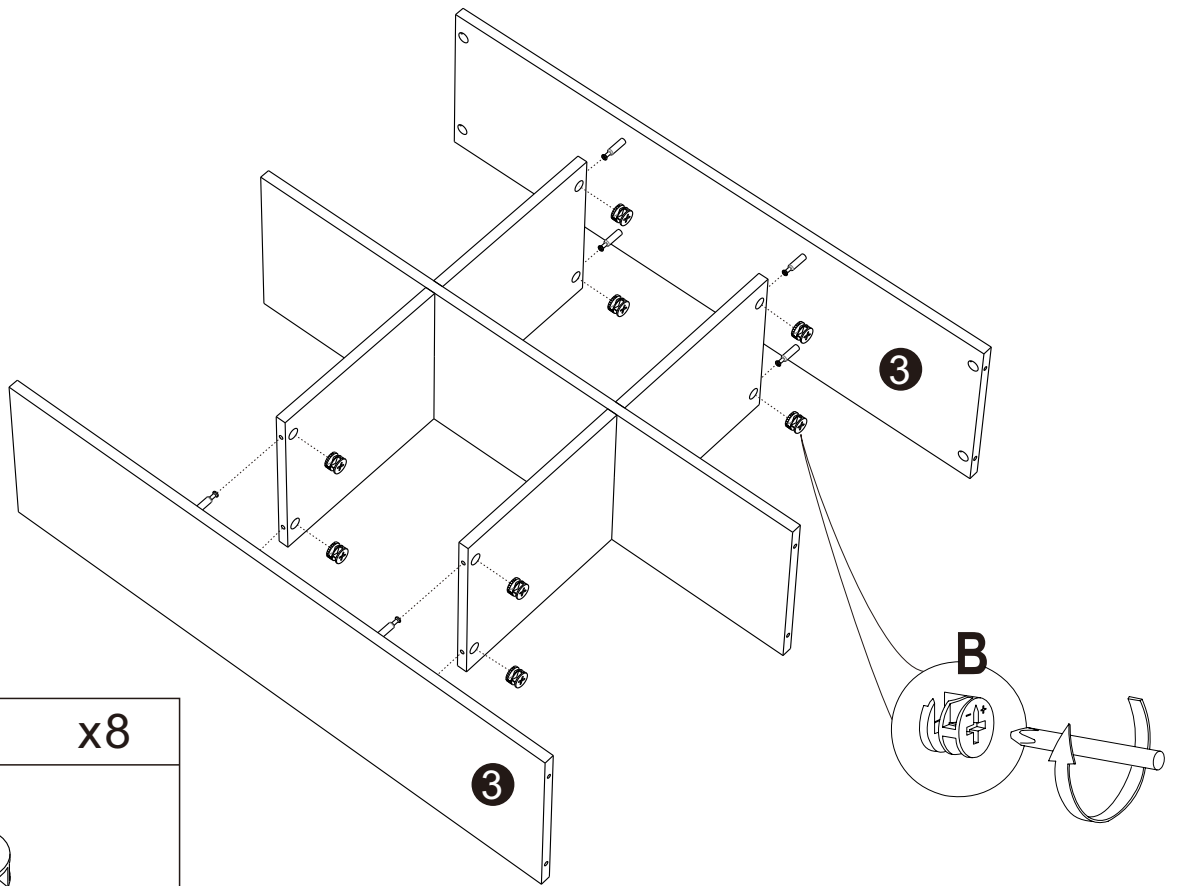

4

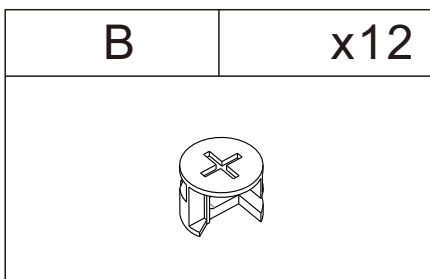
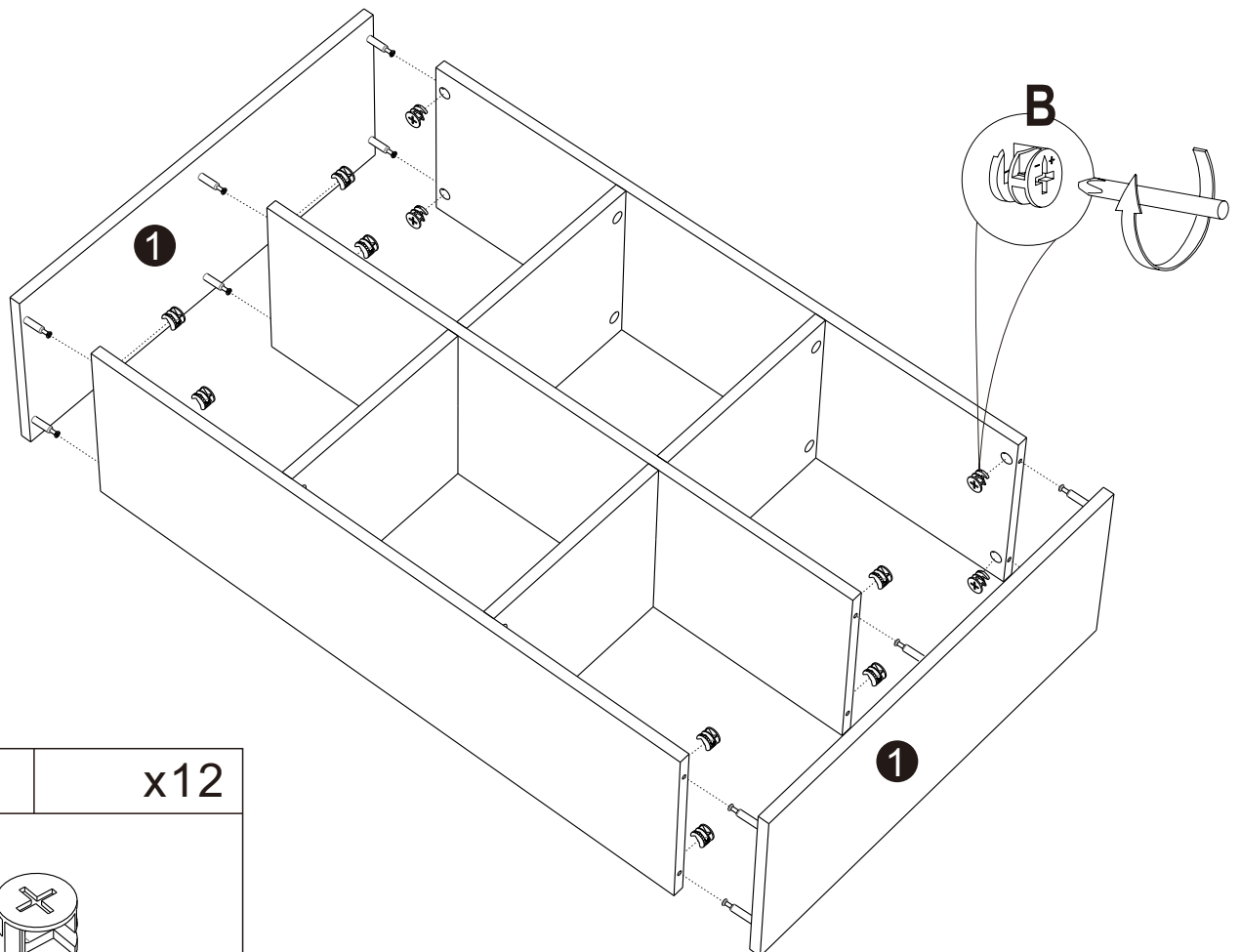

5

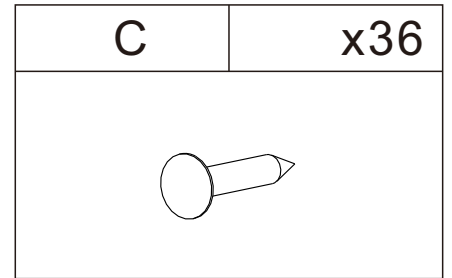
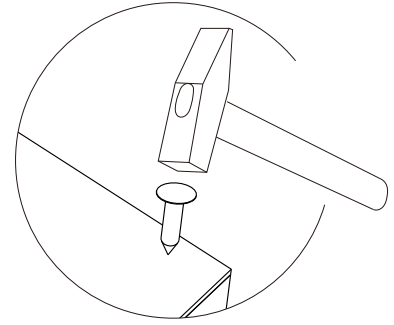
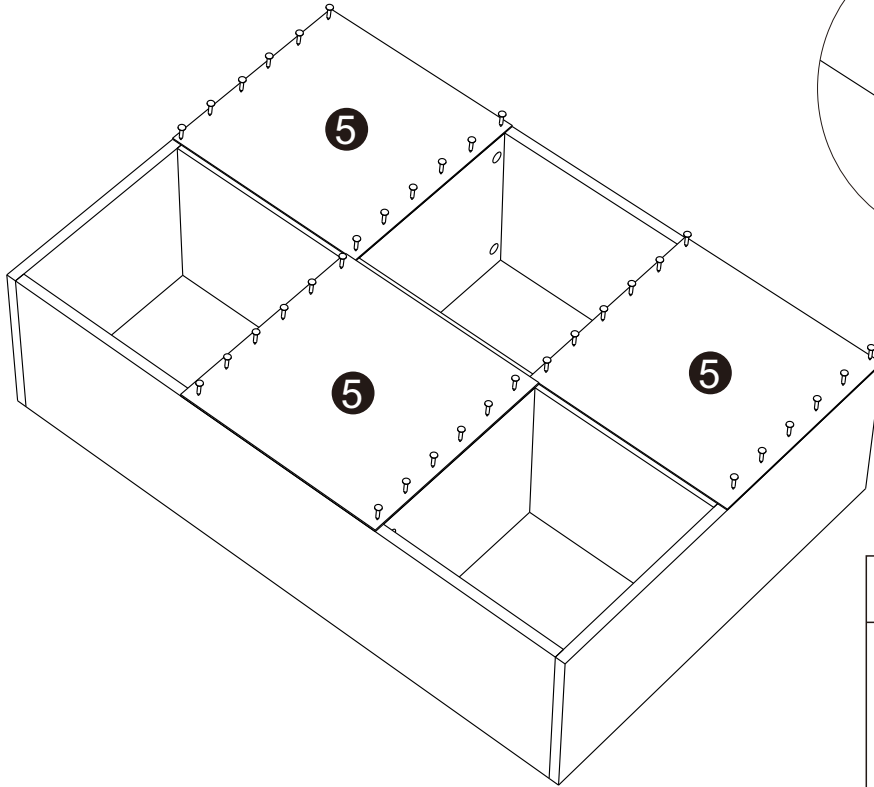

6

