

Tools Recommended

EN_IMPORTANT, RETAIN FOR FUTURE REFERENCE: READ CAREFULLY.

FR_IMPORTANT: A LIRE ATTENTIVEMENT ET À CONSERVER POUR CONSULTATION ULTÉRIEURE.

ES_IMPORTANTE, LEA Y GUARDE PARA FUTURAS REFERENCIAS.

DE_WICHTIG! SORGFÄLTIG LESEN UND FÜR SPÄTER NACHSCHLAGEN AUFBEWAHREN.

IT_IMPORTANTE! CONSERVARE IL PRESENTE MANUALE PER FUTURO RIFERIMENTO E LEGGERLO ATTENTAMENTE.

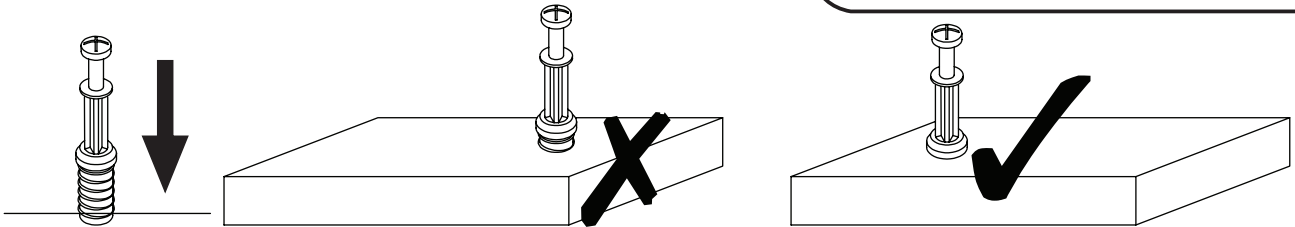

EN_QUICKFIT: Tighten quickfit until shoulder is flush with panel. Do not overtighten or undertighten.

FR_RACCORD RAPIDE: Faites serrer le raccord rapide jusqu'à ce que l'épaulement soit parfaitement encastré dans le panneau. Il ne faut ni trop serrer ni insuffisamment serrer.

ES_QUICKFIT: Apriete quickfit hasta que el hombro se descargue con el panel. NO lo sobreapriete ni lo apriete poco.

DE_QUICKFIT: Ziehen Sie den Quickfit fest, bis die Schulter mit der Platte bündig ist. Bitte nicht zu fest oder zu schwach anziehen.

IT_MONTAGGIO RAPIDO: Stringere il montaggio rapido fino a quando la spalla è a filo con il pannello, non stringere troppo o troppo poco.

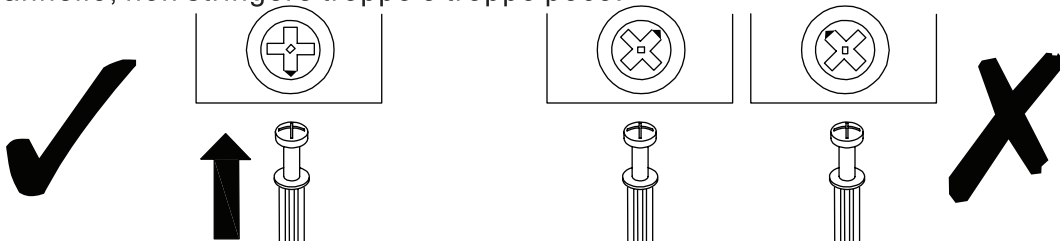

EN_CAM LOCK: When fitting cam lock, ensure starting position is correct before you insert connecting quickfit.

FR_SERRURE BATTEUSE: Avant d'insérer la serrure batteuse, veillez à la bonne orientation avant d'insérer le raccord rapide.

ES_CIERRE DE LA CÁMARA: Cuando instale el cierre de la cámara, asegúrese de que la posición de inicio es correcta antes de que inserte el quickfit conector.

DE_CAM-LOCK: Achten Sie bei der Montage des Cam-Locks auf die richtige Ausgangsposition, bevor Sie den Quickfit einsetzen.

IT_BLOCCAGGIO A CAMMA: Quando si monta il bloccaggio a camma, assicurarsi che la posizione iniziale sia corretta prima di inserire il montaggio rapido di collegamento.

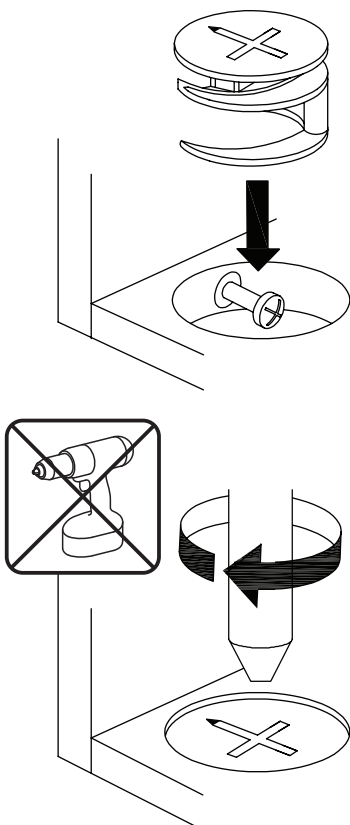

EN_Quickfit head should be in the centre of the cam lock when the two panels are joined.

Cam lock should be inserted before quickfit.

FR_Lorsque les deux panneaux sont assemblés, la tête du raccord rapide doit reposer au centre de la serrure batteuse.

Il faut insérer la serrure batteuse avant le raccord rapide.

ES_El cabezal del quickfit debe estar en el centro del cierre de la cámara cuando se unan los dos paneles.

Se debe insertar el cierre de la cámara antes que el quickfit.

DE_Der Quickfit-Kopf sollte sich in der Mitte des Cam-Locks befinden, wenn die beiden Platten zusammengefügt sind.

Der Cam-Lock sollte vor dem Quickfit eingesetzt werden.

IT_La testa del montaggio rapido deve trovarsi al centro del bloccaggio a camma quando i due pannelli sono uniti.

Il Bloccaggio a Camma deve essere inserito prima del montaggio rapido.

EN_Turn cam lock clockwise to tighten.







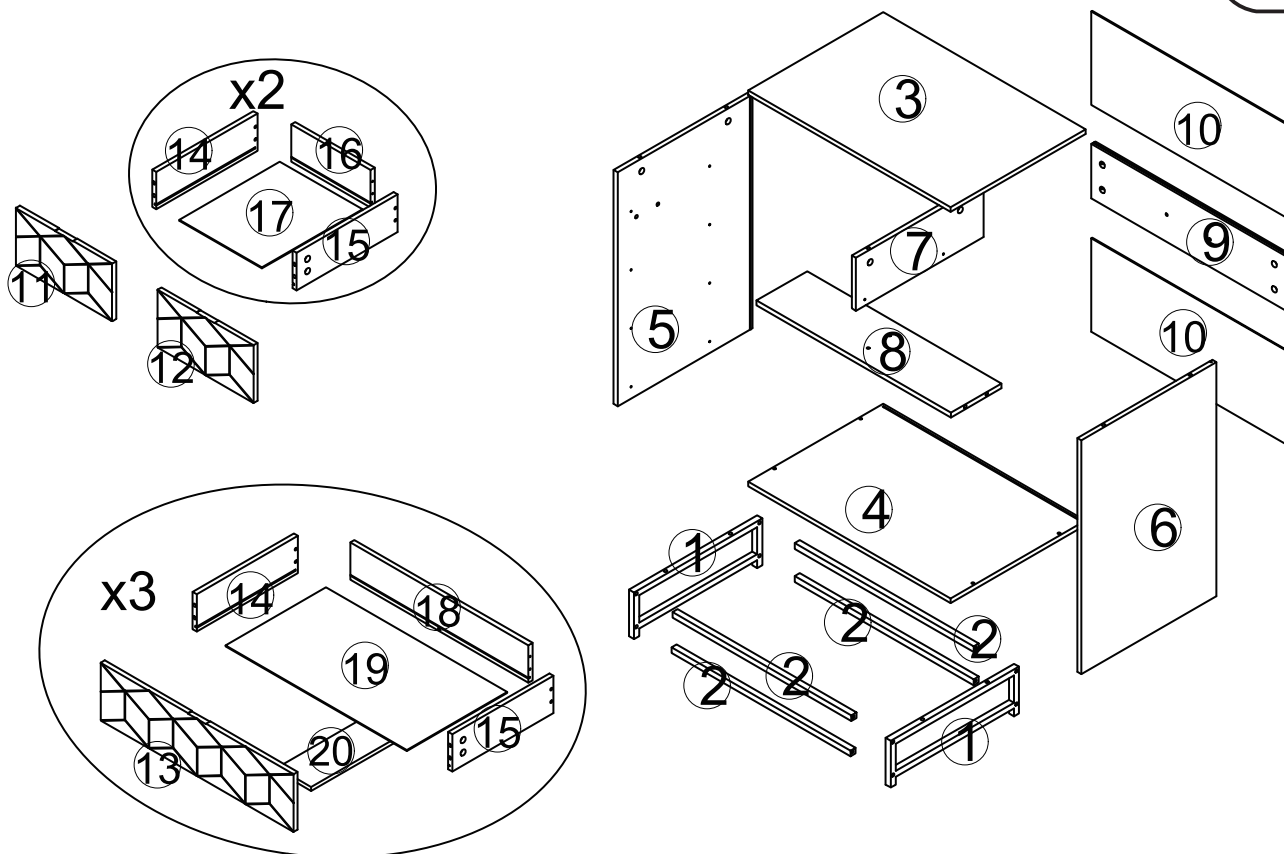

FR_Faites tourner la serrure batteuse dans le sens des aiguilles d'une montre pour la resserrer.

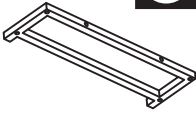
ES_Gire el cierre de la cámara en sentido horario para apretarlo.

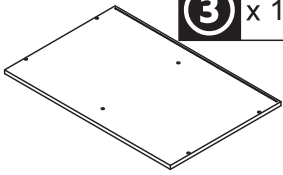
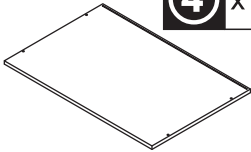
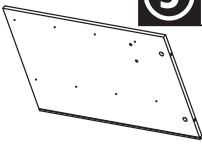
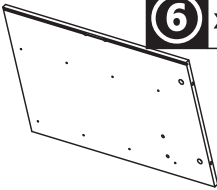
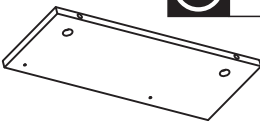
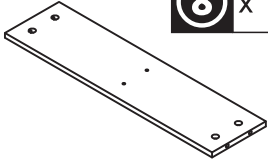
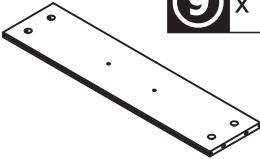
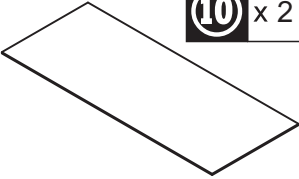
DE_Drehen Sie den Cam-Lock im Uhrzeigersinn, um ihn festzuziehen.

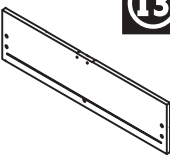
IT_Ruotare il bloccaggio a camma in senso orario per stringere.

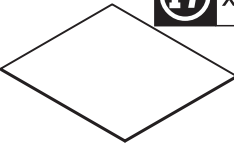
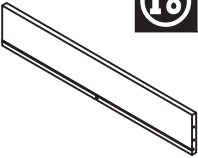
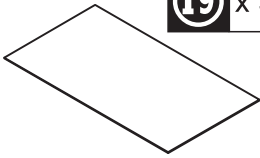
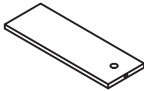

 1 x 2	 2 x 4	 3 x 1	 4 x 1
 5 x 1	 6 x 1	 7 x 1	 8 x 1
 9 x 1	 10 x 2	 11 x 1	 12 x 1
 13 x 3	 14 x 5	 15 x 5	 16 x 2
 17 x 2	 18 x 3	 19 x 3	 20 x 3

A x34

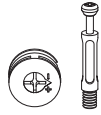

B x 6
M5*50



C x50
M4*14
+2(spare)



D x25
M4*40
+1(spare)

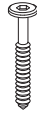

E x 8
M6*35
+1(spare)



F x 4
M6*30



G x 3



J x 4



M x 5



K x 5



L x 1



01

A x8



M x2



C x4



D x8

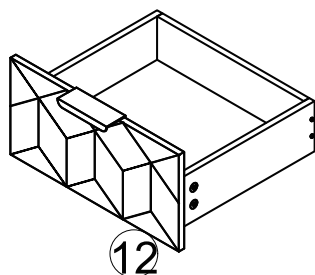
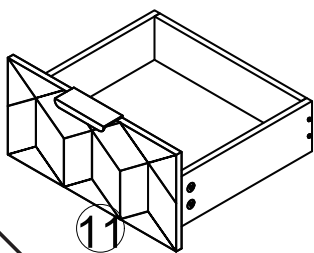
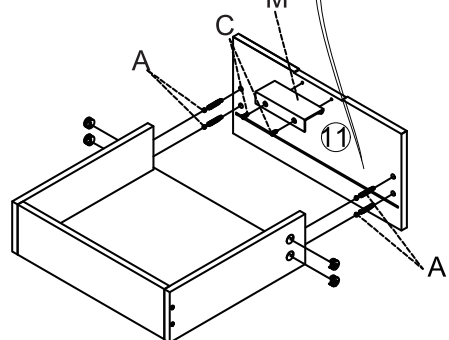
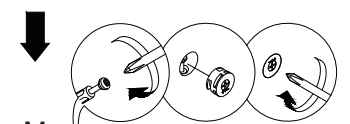
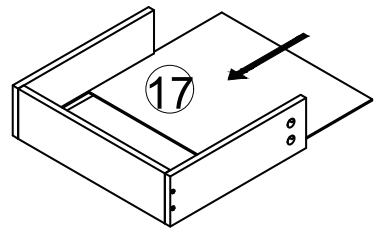
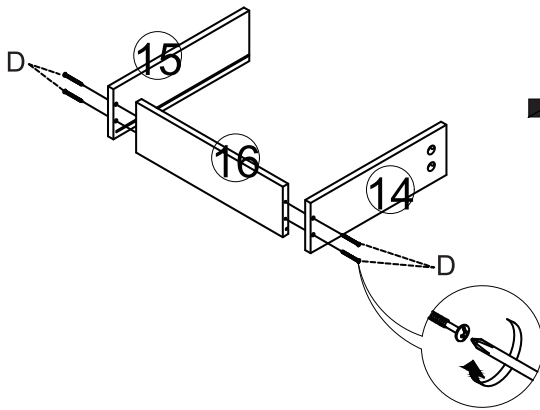

x2

A x12

M x3

G x3

C x6

D x15

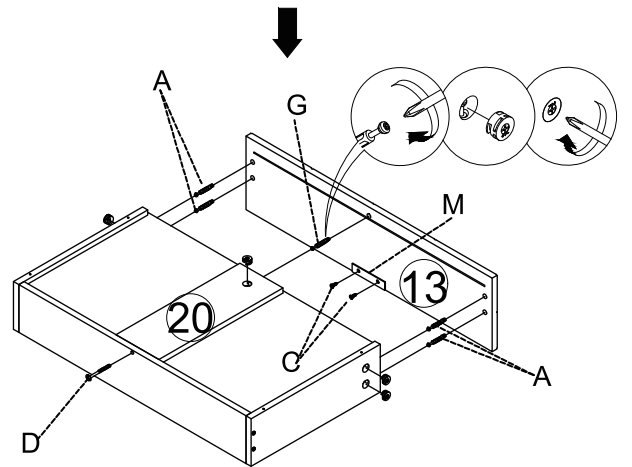
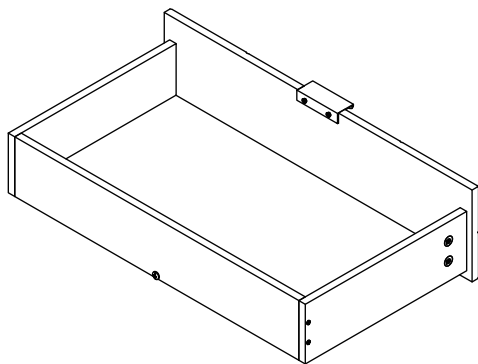
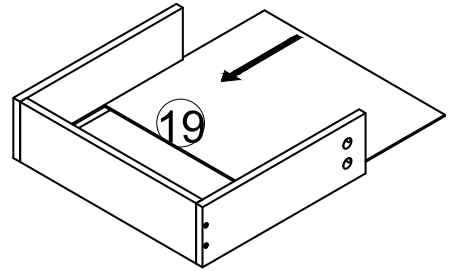
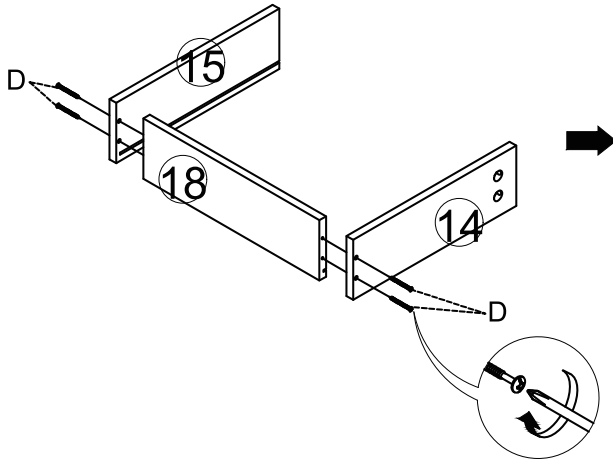

x3

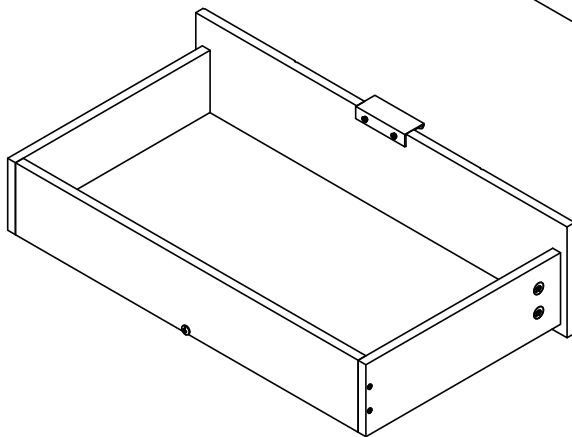
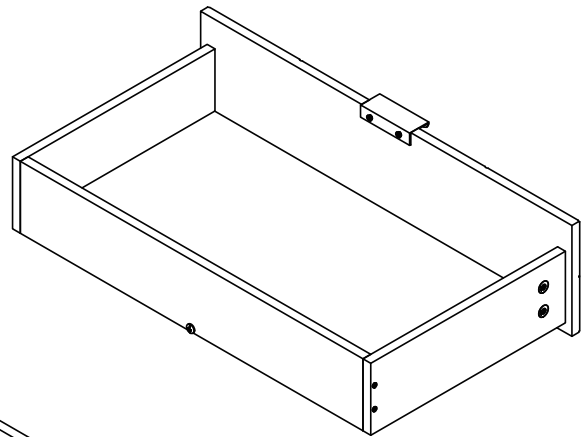
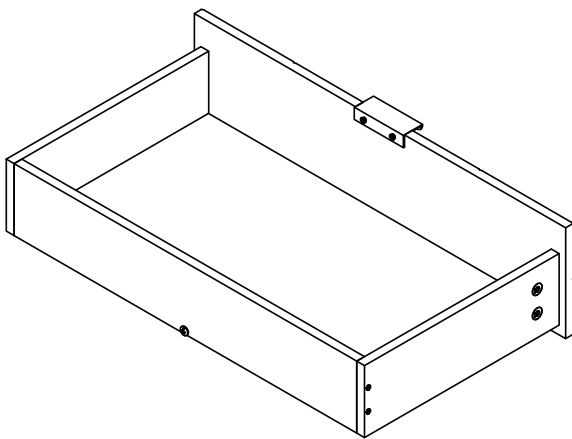

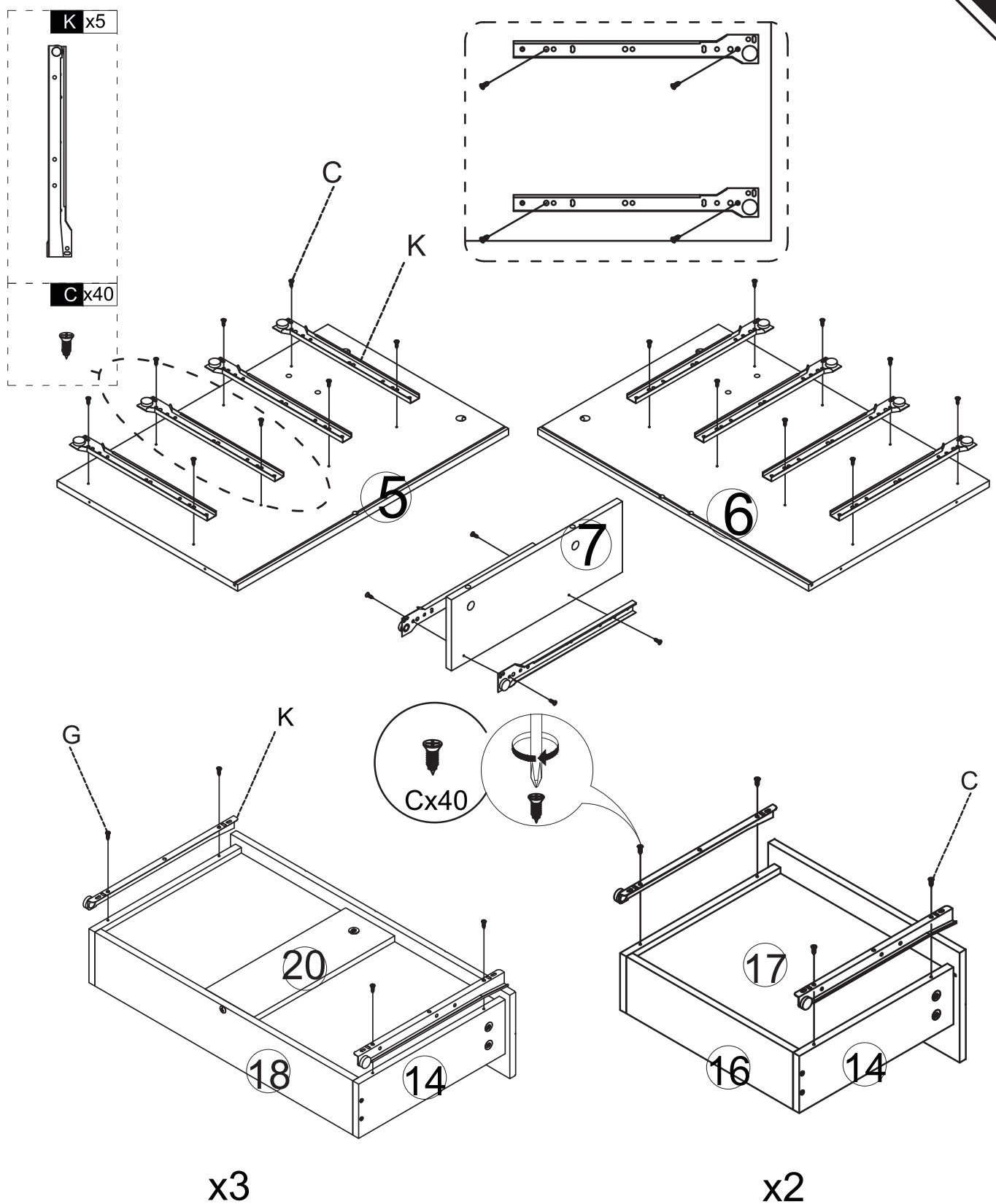

x3

x2

EN Please find the exact hole for installation, otherwise it will be misaligned. The screws on the drawer slide must be leveled, otherwise it will affect the smoothness of the drawer.

FR Veuillez repérer le trou exact pour l'installation, sinon il sera mal aligné. Les vis de la glissière du tiroir doivent être nivelées, sinon cela affectera la douceur du tiroir.

ES Encuentre el orificio exacto para la instalación; de lo contrario, estará desalineado. Los tornillos de la guía del cajón deben estar nivelados, de lo contrario afectará a la suavidad del cajón.

DE Bitte benutzen Sie die exakten Bohrungen für die Installation, sonst wird sie falsch ausgerichtet. Die Schrauben an der Schubladenföhrung müssen nivelliert werden, da sie sonst die Leichtgängigkeit der Schublade beeinträchtigen.

IT Si prega di individuare il foro corretto per l'installazione, altrimenti sarà disallineato. Le viti della guida del cassetto devono essere livellate, altrimenti la scorrevolezza del cassetto ne risentirà.

B x2

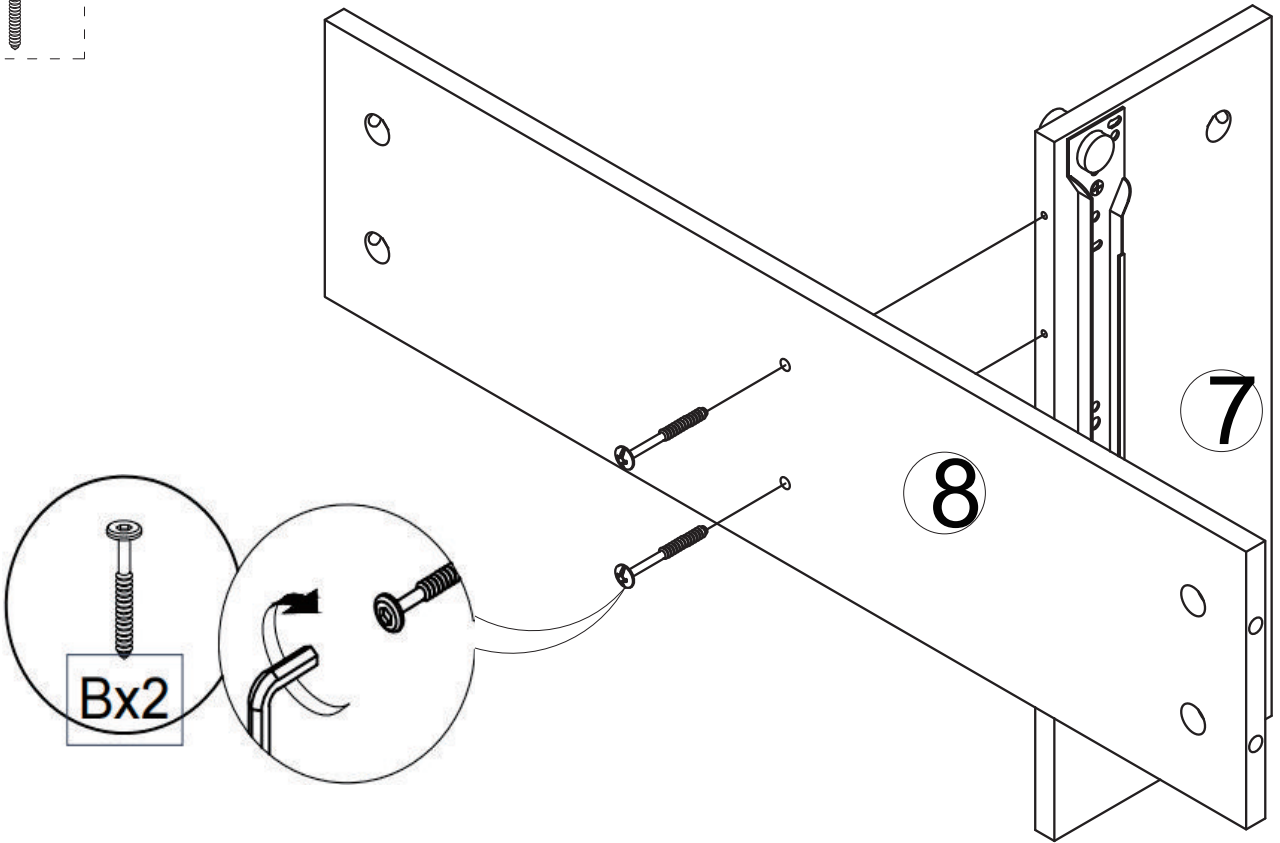
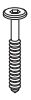

A x8

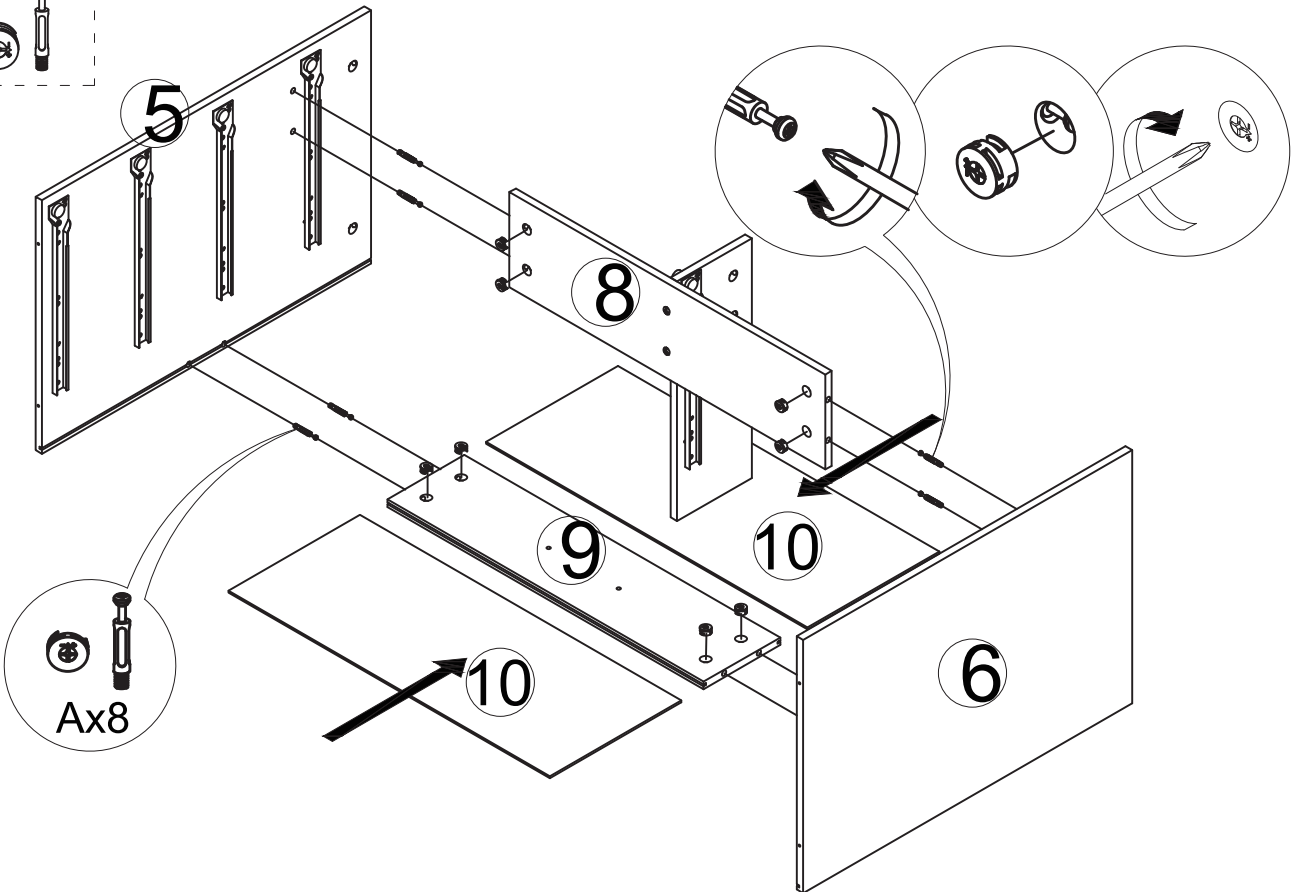

A x6

B x4

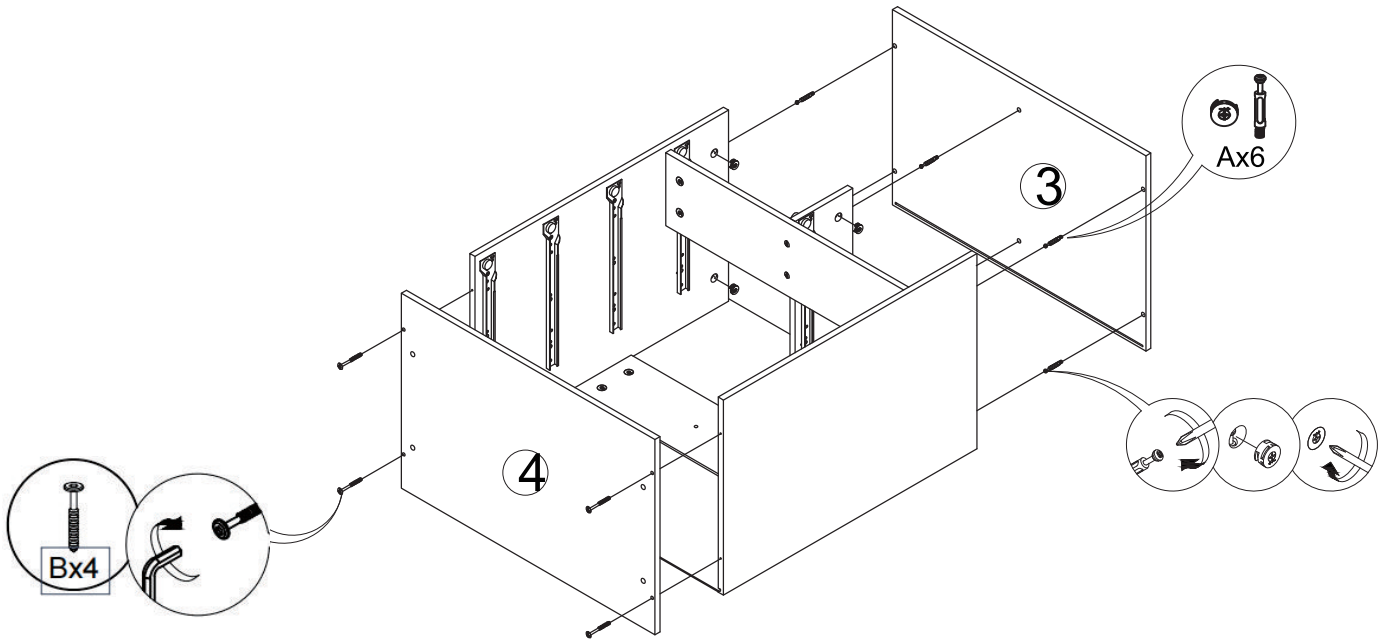
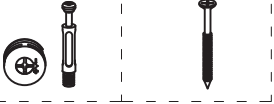

J x4

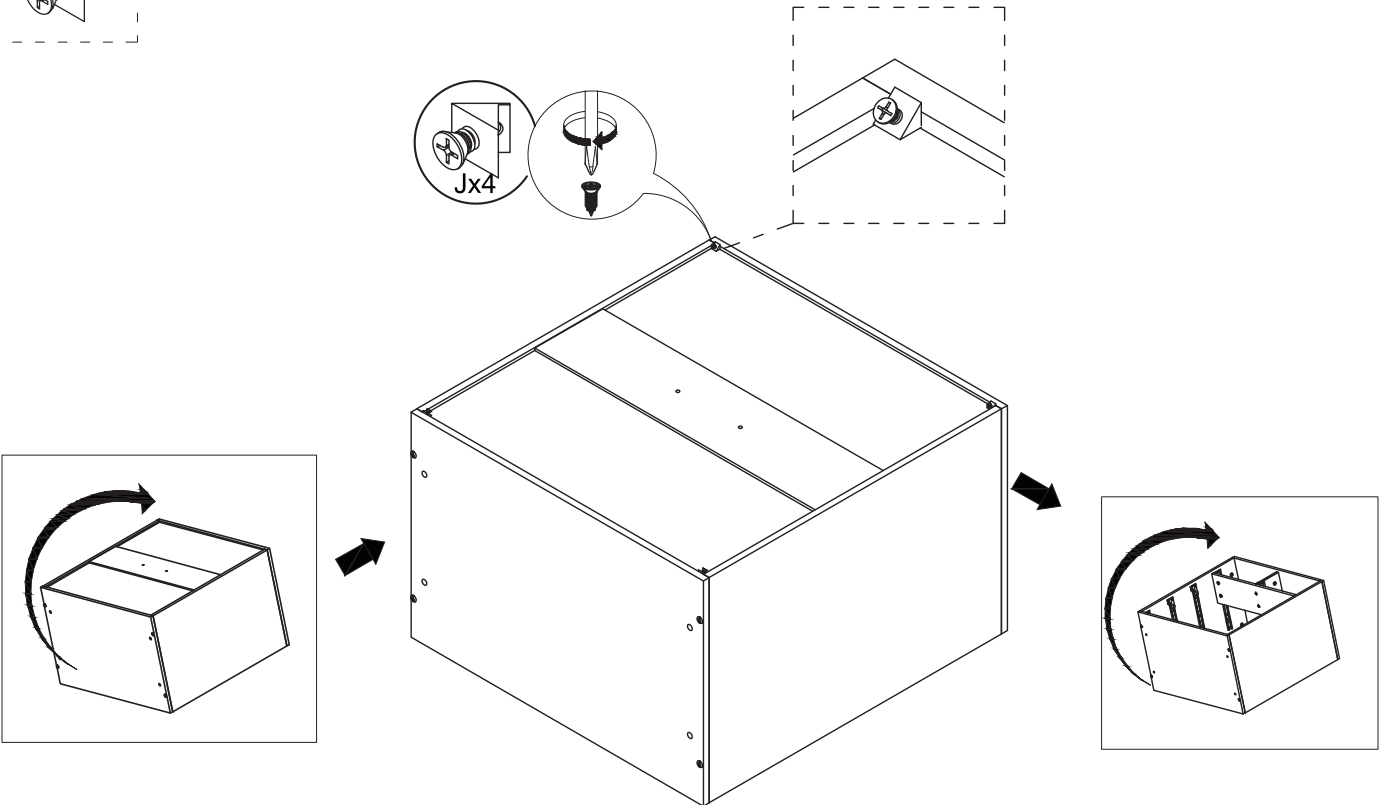
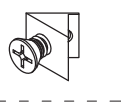

E x8

F x4

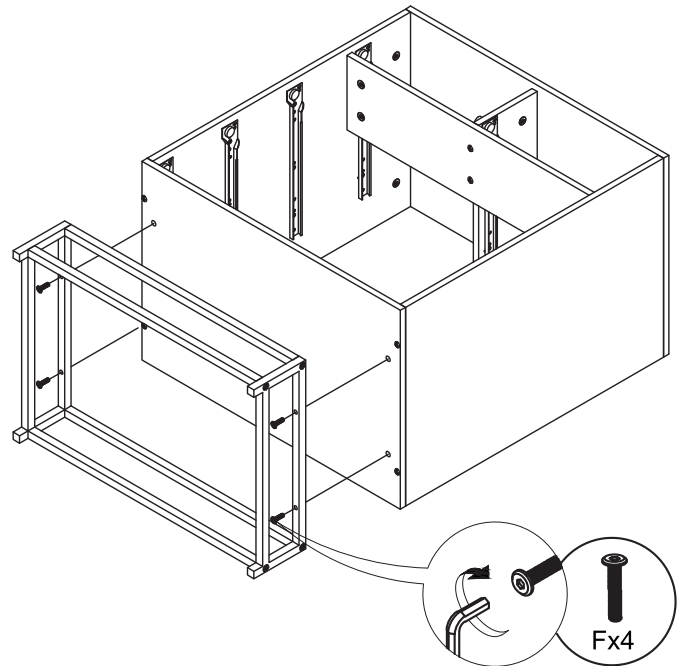
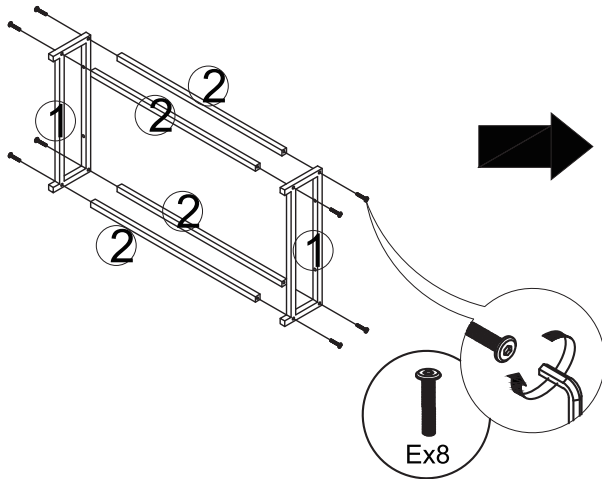

D x2

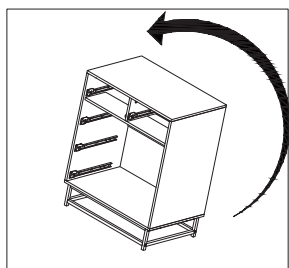
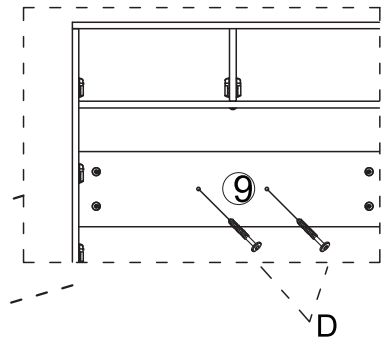
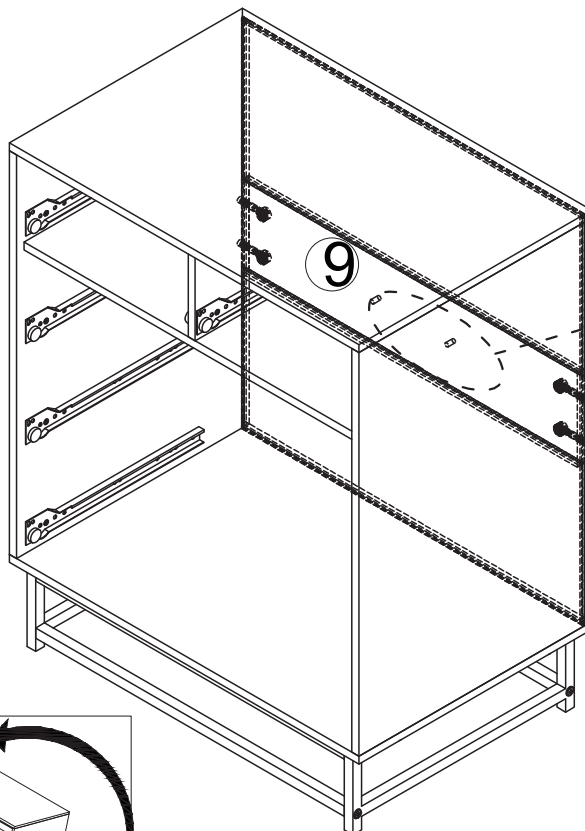

EN As shown in the figure, the screw D is passed through the holes of Part 9 to fix the cabinet on the wall.

FR Comme indiqué sur la figure, la vis D est passée dans les trous de la pièce 9 pour fixer l'armoire au mur.

ES Como se muestra en la figura, el tornillo D se pasa a través de los agujeros de la pieza 9 para fijar el armario en la pared.

DE Wie in der Abbildung dargestellt, wird die Schraube D durch die Löcher von Teil 9 geführt, um den Schrank an der Wand zu befestigen.

IT Come mostrato in figura, la vite D viene fatta passare attraverso i fori del pezzo 9 per fissare il mobile alla parete.

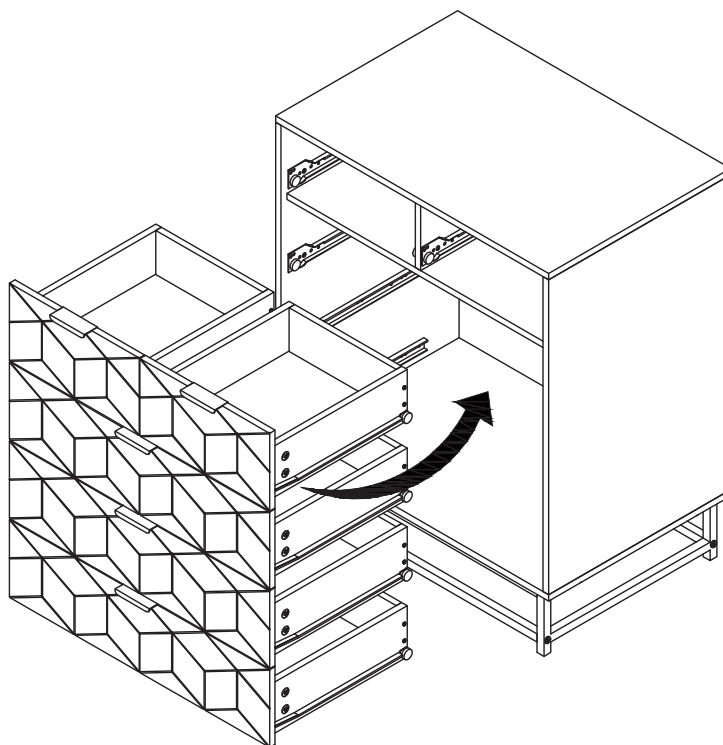

EN Be careful to push in the board when the both sides slide way been aligned.

FR Prenez soin d'enfoncer la carte lorsque les deux côtés coulissants sont alignés.

ES Tenga cuidado al empujar el tablero cuando los ambos lados se hayan alineado.

DE Achten Sie darauf, dass Sie die Platte einschieben, wenn der Gleitweg auf beiden Seiten ausgerichtet ist.

IT Prestare attenzione quando si spinge l'asse se entrambi i lati sono allineati.

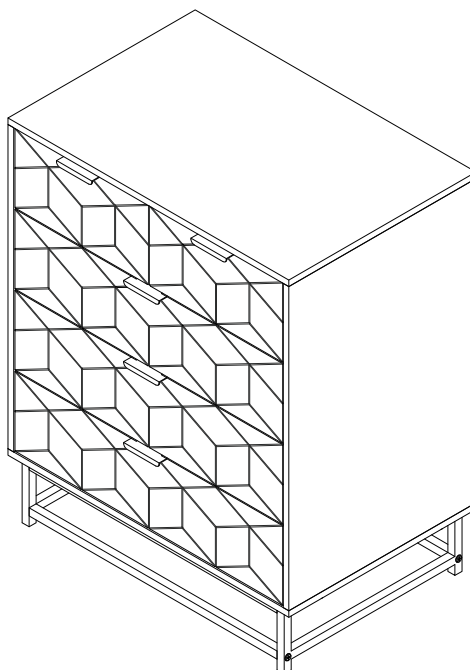

FR

**Pensez à
donner ou recycler.**



Association

ou



Magasin

ou



Déchèterie

<https://quefairedemesdechets.fr>