



INcpb044_CA_IT

838-264V00

Five-Tier Multi-Purpose Metal Shelf

EN

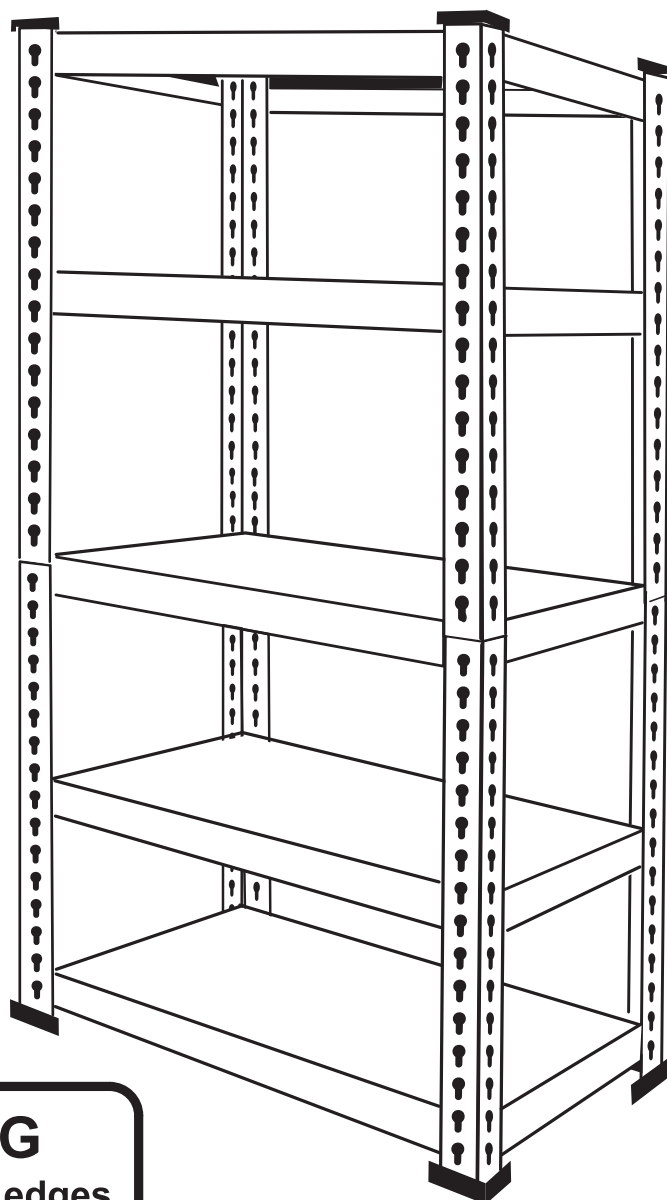

WARNING

Handle cut metal edges
carefully.

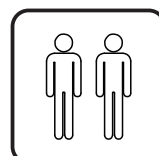

IMPORTANT, RETAIN FOR FUTURE REFERENCE: READ CAREFULLY

ASSEMBLY INSTRUCTION

The only tool you require is a MALLET

LIST OF PARTS



8 x Keyhole tracks



8 x Plastic feet



5 x 6mm MDF shelves



10 x Long shelf supports



10 x Short shelf supports

1. Attach four plastic feet onto the ends of four keyhole tracks.

NOTE: Ensure keyholes are the correct way up.

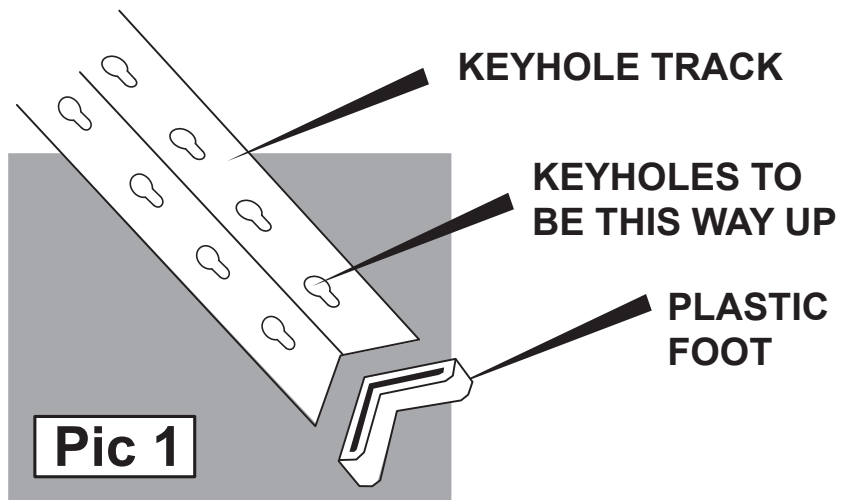

2. Using four keyhole tracks, fit two short and two long shelf supports into the bottom keyholes (for maximum strength) by slotting the pins in the supports into the keyholes of the tracks – tap firmly with a mallet to secure in place.

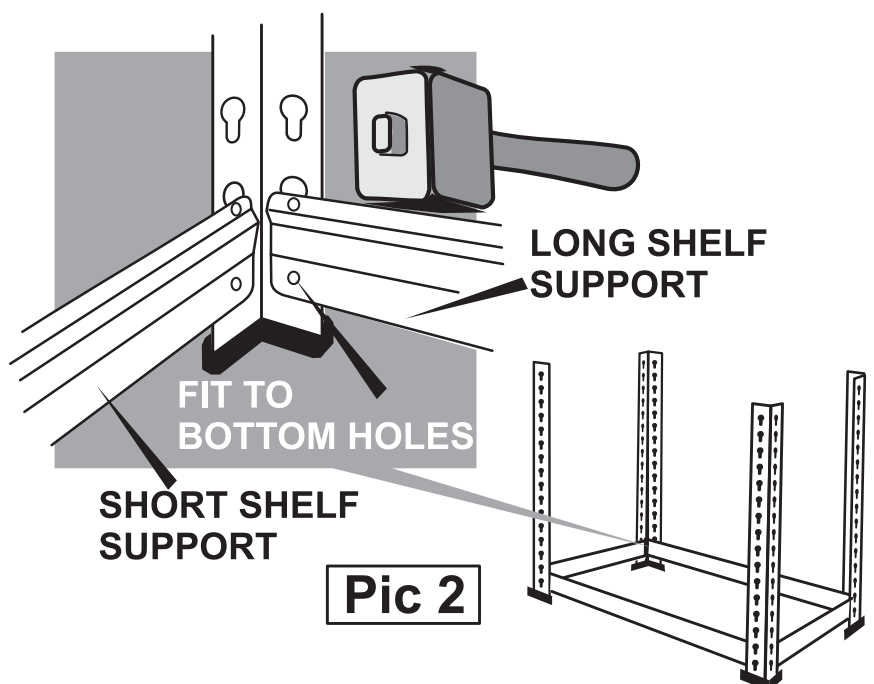

3. Fit long and short shelf support into your desired position. Do not place these supports into the top two holes of the track (Pic 3). (There are position recommendations below).

SHELF SUPPORTS FOR 2ND SHELF

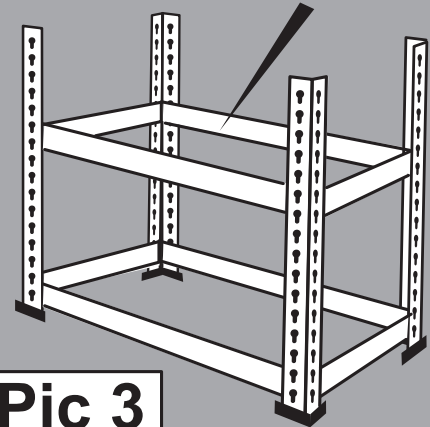

Pic 3

4. (GO TO STEP 5 IF YOU ARE NOT ASSEMBLING AS A WORKBENCH)

- a) Fit two long shelf supports for the top of the workbench into the top keyholes, then fit one centre brace to these shelf supports.
- b) Use the remaining keyhole tracks, long and short shelf supports and centre braces to assemble a straight or corner workbench, following the same method as above.
- c) Install MDF shelves.
- d) Bolt has two halves of the workbench together if needed (nuts and bolts not supplied).

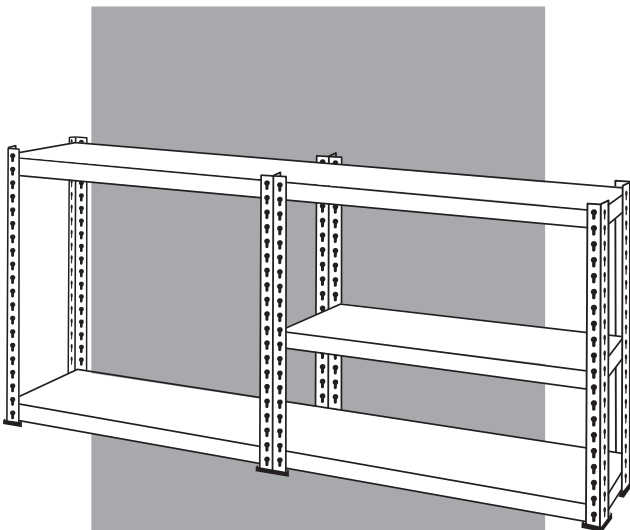

**STRAIGHT
WORKBENCH**

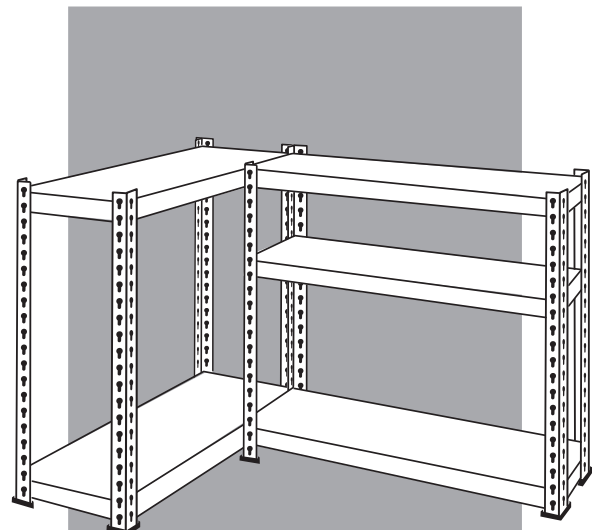

**CORNER
WORKBENCH**

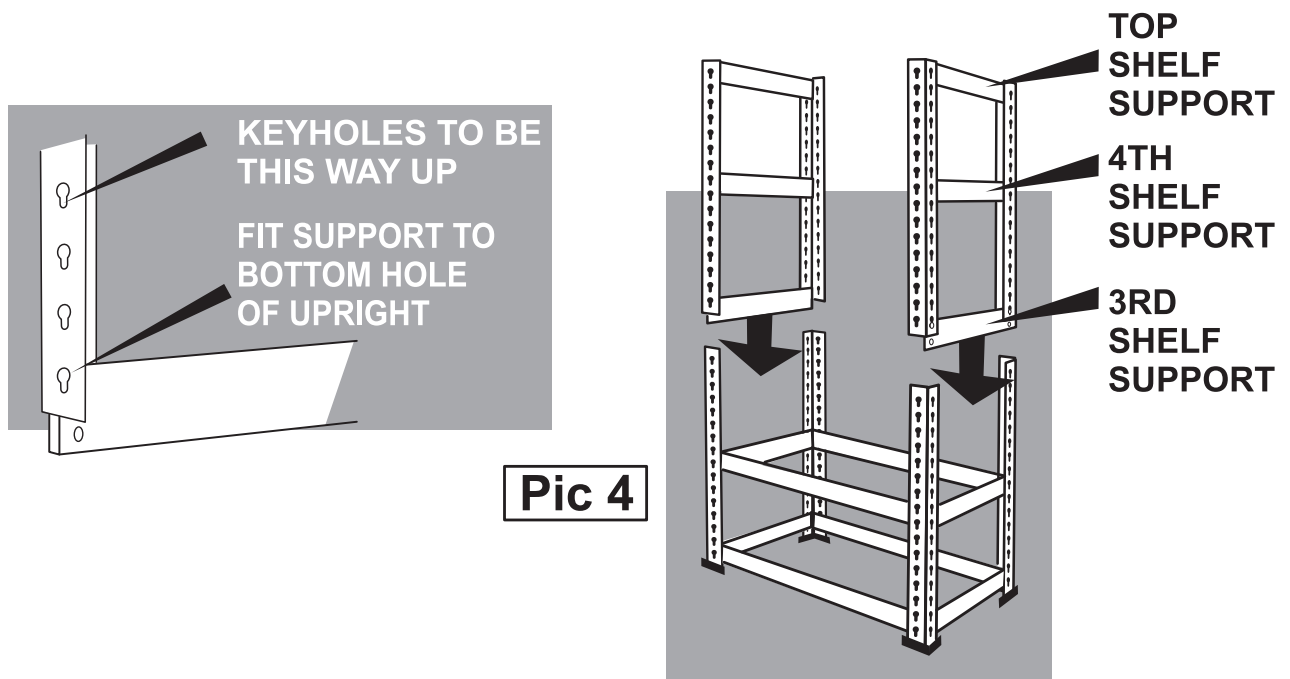

5. To make one side of the top half for the storage unit: Fit three short shelf supports, using two keyhole tracks. Fit the top support first. It must be in the top two holes of the track. Then fit the fourth support and lastly, the third support into the bottom hole of the track (pic 4).

Repeat the procedure to make the second side.

Fit these two top halves to the bottom half of the unit (pic 4).

6. Fit long shelf supports into the tracks, using the third, fourth and top shelf positions.

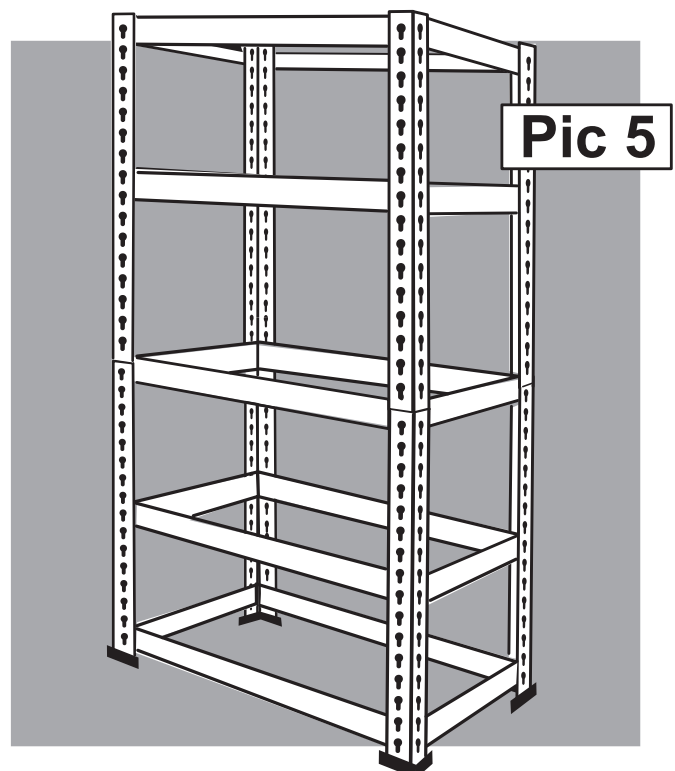

7. Place five MDF shelves onto five shelf supports – fit the remaining four plastic feet onto the tops of the key-hole tracks (pic 6).

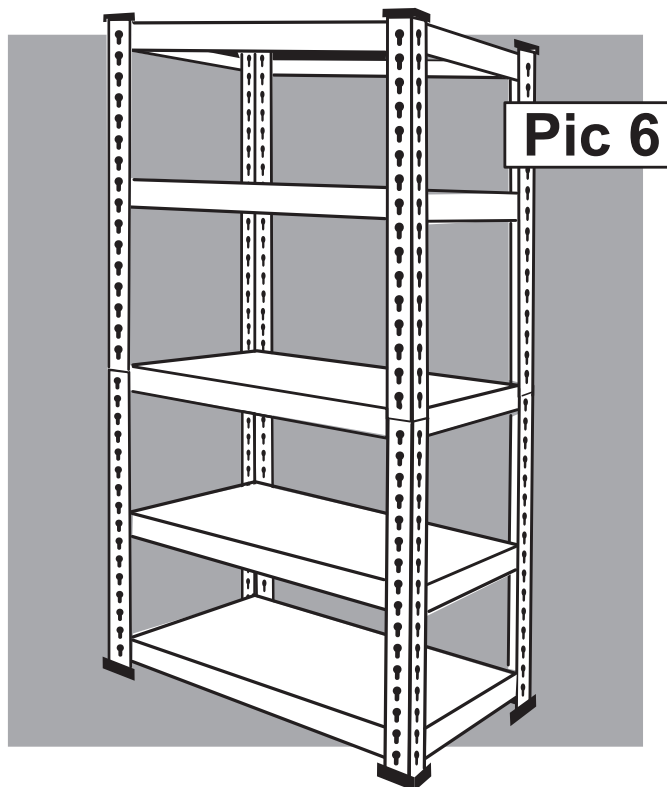

SHELF POSITION RECOMMENDATIONS

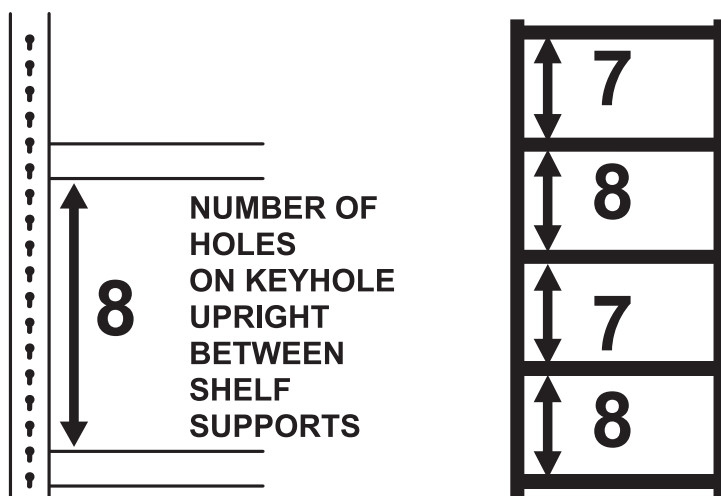

Étagère Métallique Multi-usages À Cinq Niveaux

FR

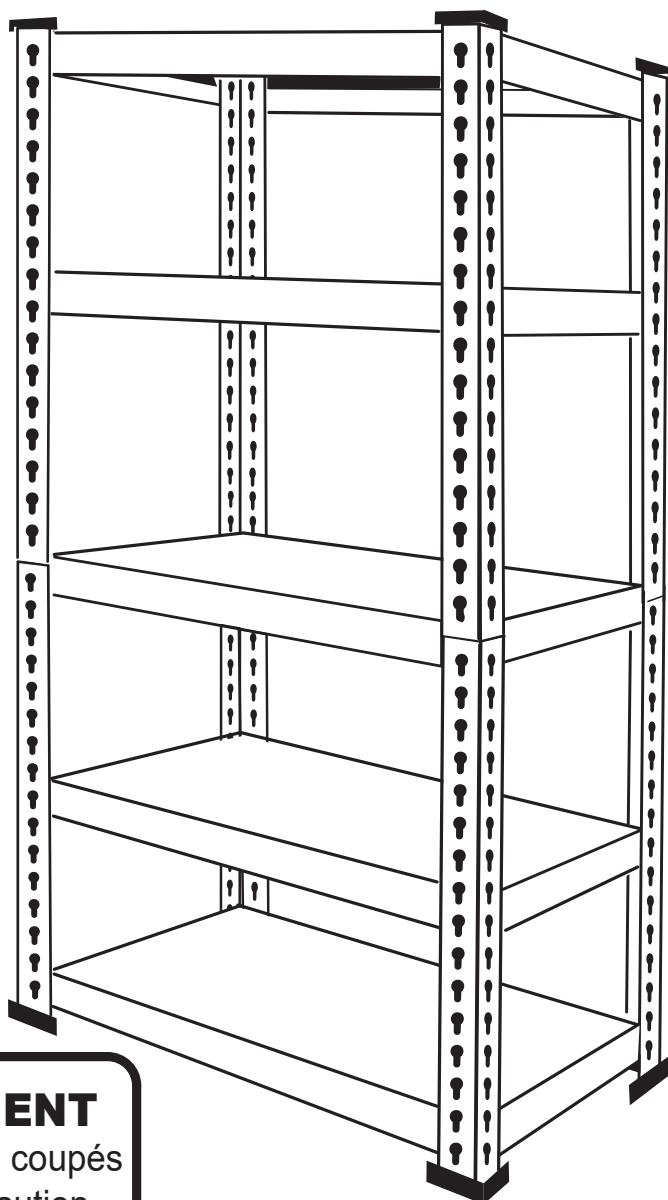

AVERTISSEMENT

Manipulez les angles coupés
du métal avec précaution.

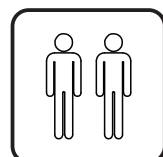

IMPORTANT - CONSERVEZ CES INFORMATIONS POUR VOTRE
CONSULTATION ULTÉRIEURE: LISEZ ATTENTIVEMENT

INSTRUCTIONS D'ASSEMBLAGE

Le seul outil dont vous aurez besoin est un MAILLET

LISTE DES PIÈCES



8 * Rails à trou de serrure



8 * Embouts en plastique



Tablettes en MDF 5*6mm



10 * Supports Longs



10 * Supports courts

1. Fixez les quatre pieds en plastique aux extrémités des quatre rails à trous de serrure.

REMARQUE : S'assurer que les trous de serrure sont orientés dans le bon sens.

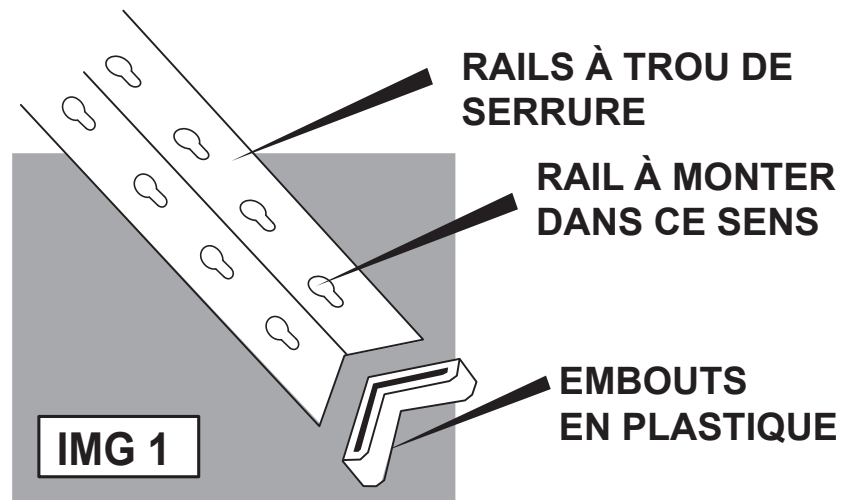

2. À l'aide de quatre rails à trous de serrure, placer deux supports d'étagère courts et deux supports d'étagère longs dans les trous de serrure inférieurs (pour une résistance maximale) en insérant les goupilles des supports dans les trous de serrure des rails - taper fermement avec un maillet pour les fixer.

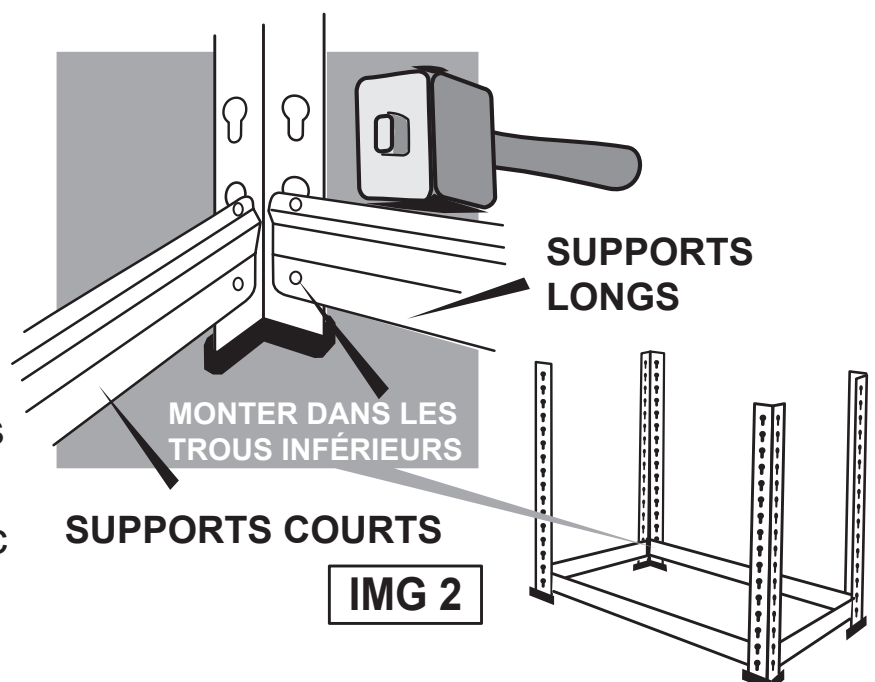

3. Montez les supports d'étagère longs et courts à la position souhaitée. Ne pas les mettre dans les deux trous supérieurs du rail (IMG 3). (Vous trouverez des recommandations de position ci-dessous).

SUPPORTS D'ÉTAGÈRE POUR LA 2ÈME TABLETTE

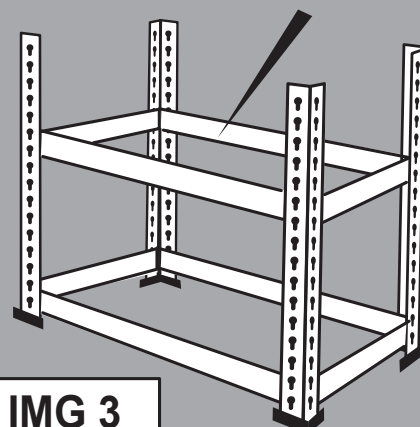

IMG 3

4. ((PASSEZ À L'ÉTAPE 5 SI VOUS NE VOULEZ PAS ASSEMBLER VOTRE ÉTAGÈRE COMME UN ÉTABLI))

a) Montez deux supports d'étagère longs pour le haut de l'établi dans les trous de serrure supérieurs, puis montez une entretoise centrale sur ces supports d'étagère.

b) Utilisez les rails à trous de serrure restants, les supports d'étagère longs et courts et les entretoises centrales pour assembler un établi droit ou d'angle, en suivant la même méthode que ci-dessus.

c) Installez les tablettes en MDF.

d) Boulonnez les deux moitiés de l'établi ensemble si nécessaire (écrous et boulons non fournis).

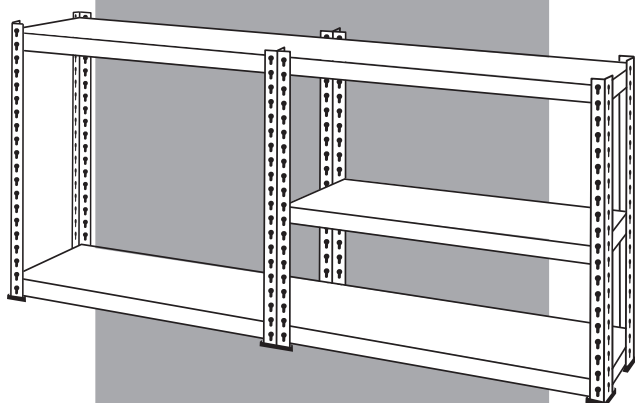

ÉTABLI DROIT

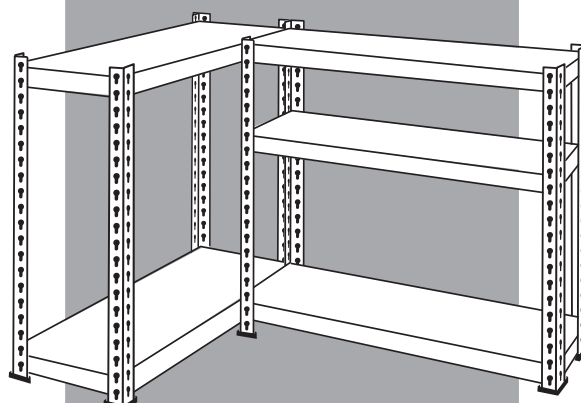

ÉTABLI D'ANGLE

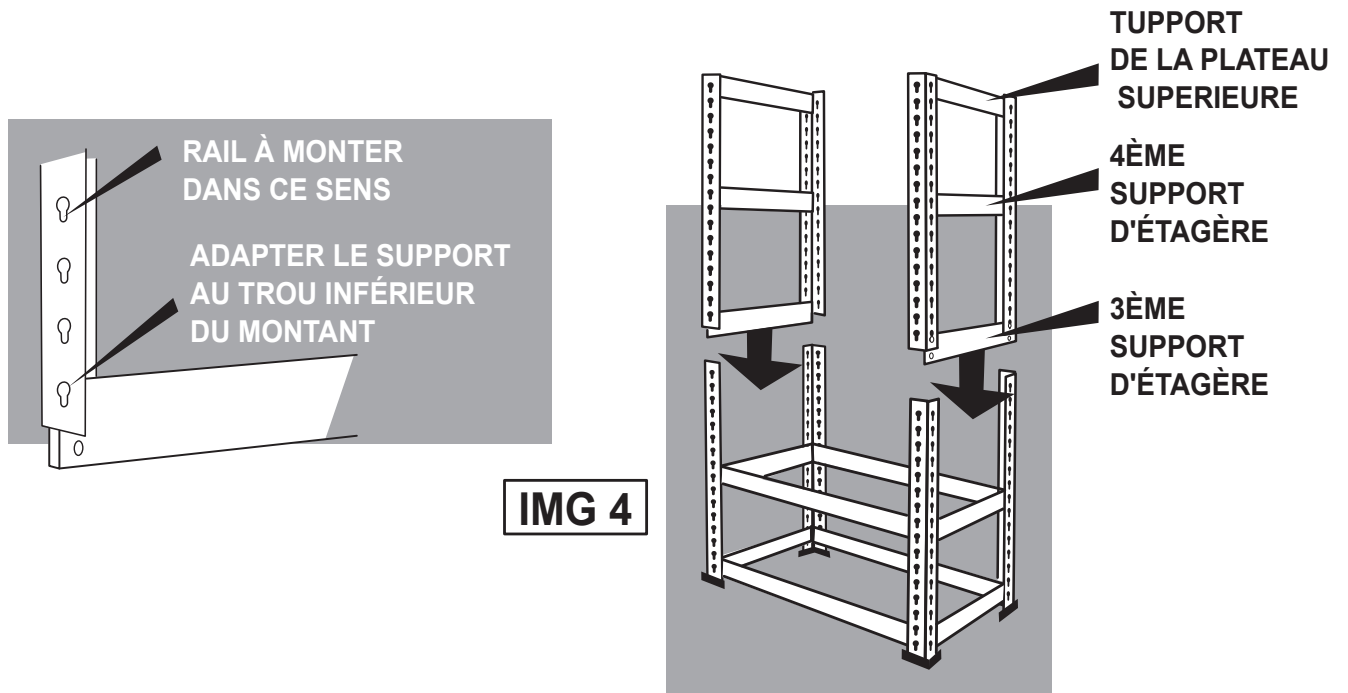

5. Pour monter un côté de la moitié supérieure de l'unité de rangement :

Monter trois supports d'étagères courts, en utilisant deux rails en trou de serrure. Installez d'abord le support supérieur. Il doit être placé dans les deux trous supérieurs du rail. Montez ensuite le quatrième support et pour finir, le troisième support dans le trou inférieur du rail (image 4).

Répétez la procédure pour faire le second côté.

Fixez ces deux moitiés supérieures à la moitié inférieure de l'unité (image 4).

6. Fixez les longs supports d'étagères dans les rails, en plaçant les troisième, quatrième et dernière tablettes.

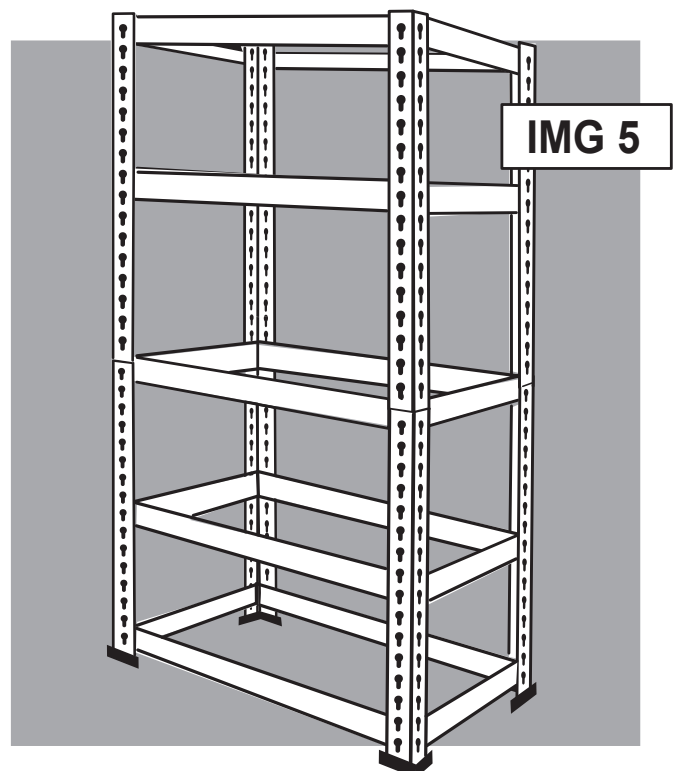

7. Placez cinq tablettes en MDF sur cinq supports d'étagères - placez les quatre embouts en plastique restants sur le dessus des Rails à trou de serrure (IMG 6).

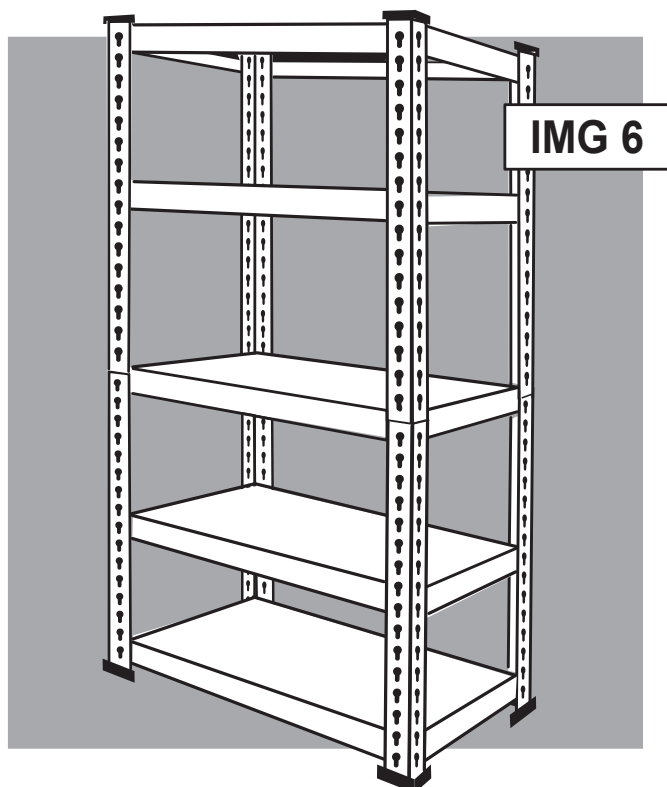

RECOMMANDATIONS POUR LA POSITION DES TABLETTES

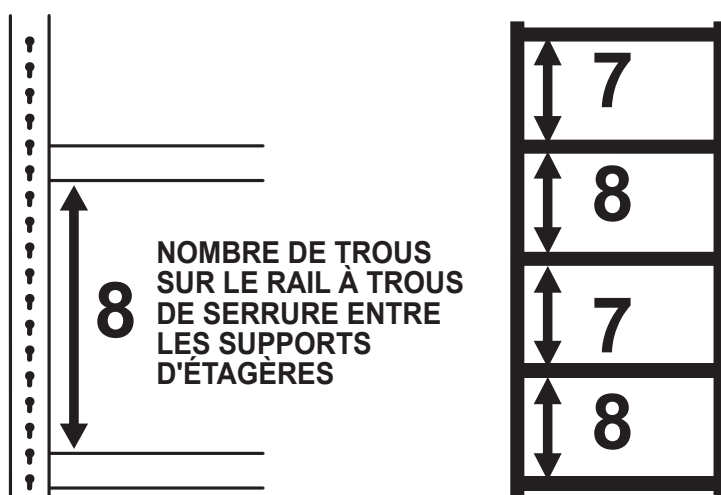

Scaffalatura a cinque livelli multiuso Scaffali in metallo

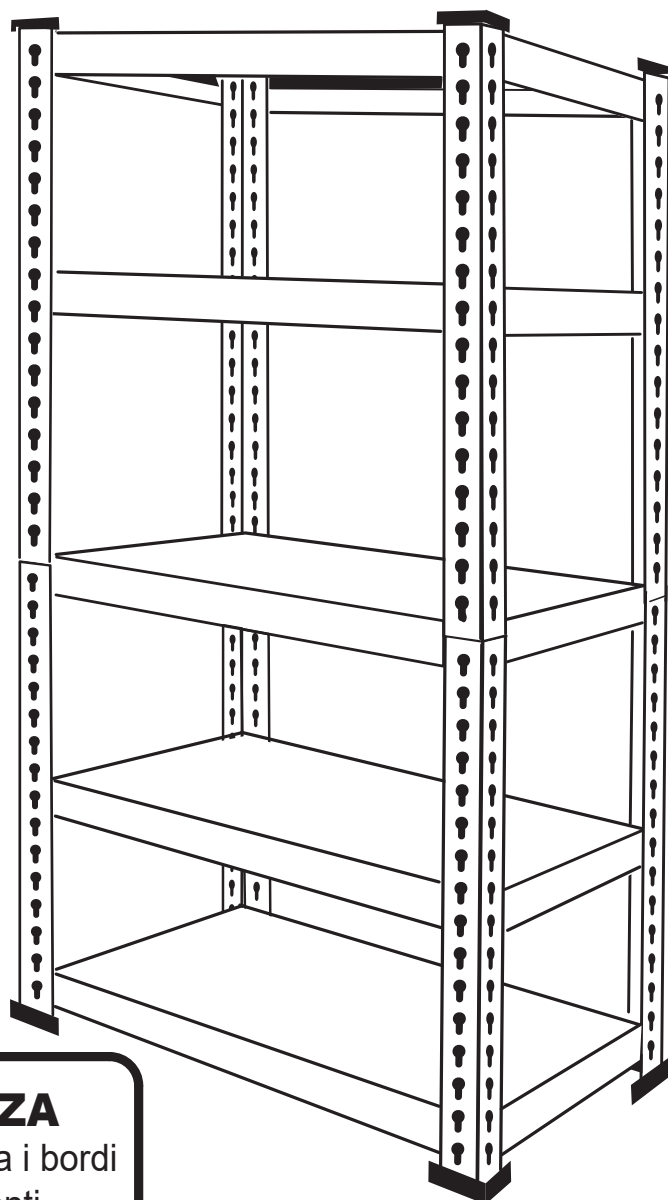
IT**AVVERTENZA**

Maneggiare con cura i bordi
di metallo taglienti

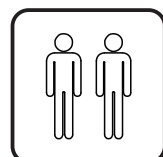

IMPORTANTE - CONSERVARE QUESTE INFORMAZIONI PER
CONSULTARLE IN SEGUITO: LEGGERE ATTENTAMENTE

ISTRUZIONI DI ASSEMBLAGGIO

L'unico strumento di cui avete bisogno è un MARTELLO

LISTE DES PIÈCES

8*Binari forati

8*Piedini in
plastica

5*6mm scaffali MDF

10*Supporti ripiani lunghi
10* Supporti ripiani corti

1. Fissare quattro piedini in plastica alle estremità dei quattro binari forati.

NOTA: assicurarsi che i fori siano inseriti in modo corretto rivolti verso l'alto.

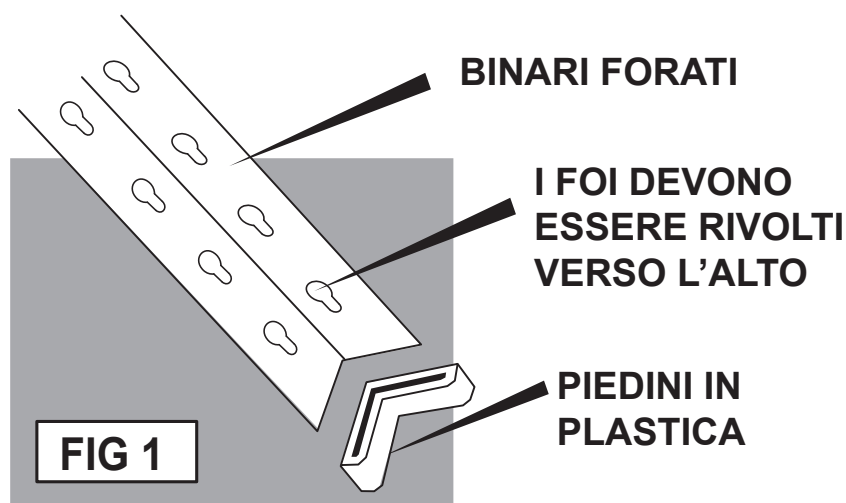

2. Usando quattro binari forati, inserire due supporti per ripiani corti e due lunghi nei fori inferiori (per ottenere la massima resistenza), inserire i perni nei fori presenti sui binari – picchiettare forte con un martello per fissarli in posizione.

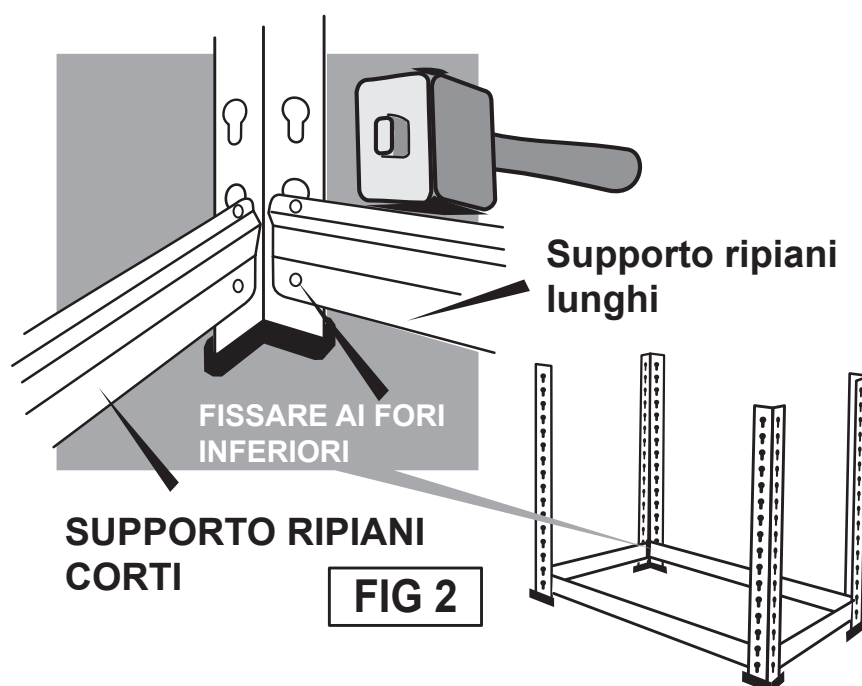

3. Montare il supporto per ripiani lunghi e corti in posizione desiderata. Non posizionare questi supporti nei due fori superiori del binario (Fig. 3). (di seguito troverete dei consigli sul posizionamento).

SUPPORTO RIPIANO PER 2DA RIPIANO

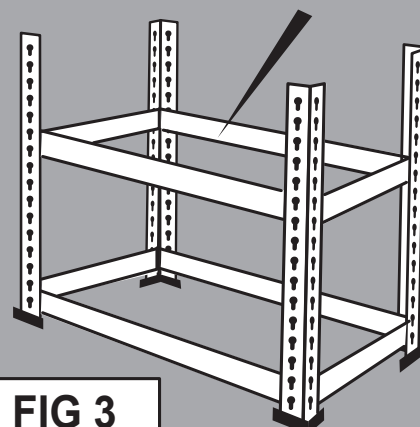
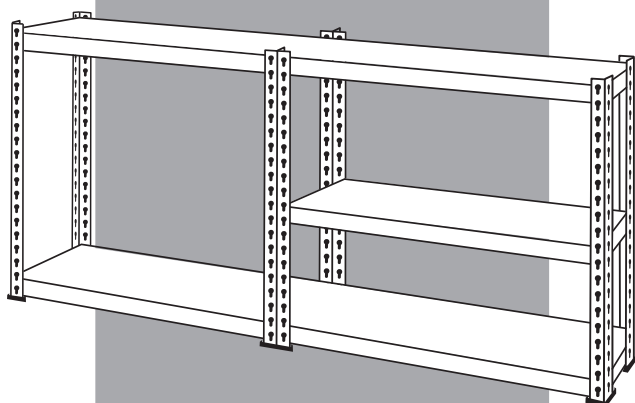

FIG 3

4. (ANDARE ALLO STEP 5 SE NON LO STATE ASSEMBLANDO COME BANCO DI LAVORO)

- Montare due supporti per ripiani lunghi per la parte superiore del banco da lavoro nei fori superiori, quindi assemblare un supporto centrale su questi supporti per ripiani.
- Utilizzare i rimanenti binari forati, i supporti per ripiani lunghi e corti e le traverse centrali per assemblare un banco da lavoro dritto o angolare, seguendo gli stessi passaggi di cui sopra.
- Installare gli scaffali MDF.
- Usare un bullone tra le due metà del banco di lavoro per tenerle insieme, se necessario (dadi e bulloni non in dotazione).



BANCO DA LAVORO DRITTO

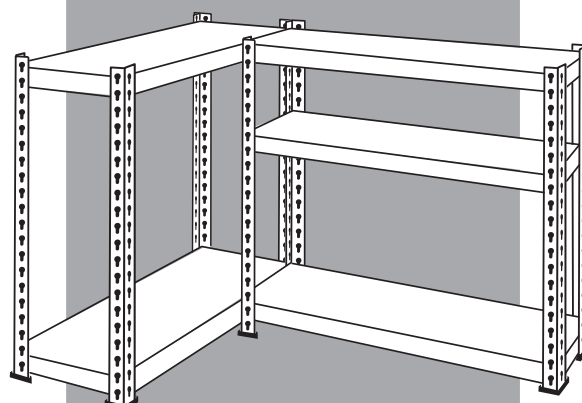

BANCO DA LAVORO ANGOLARE

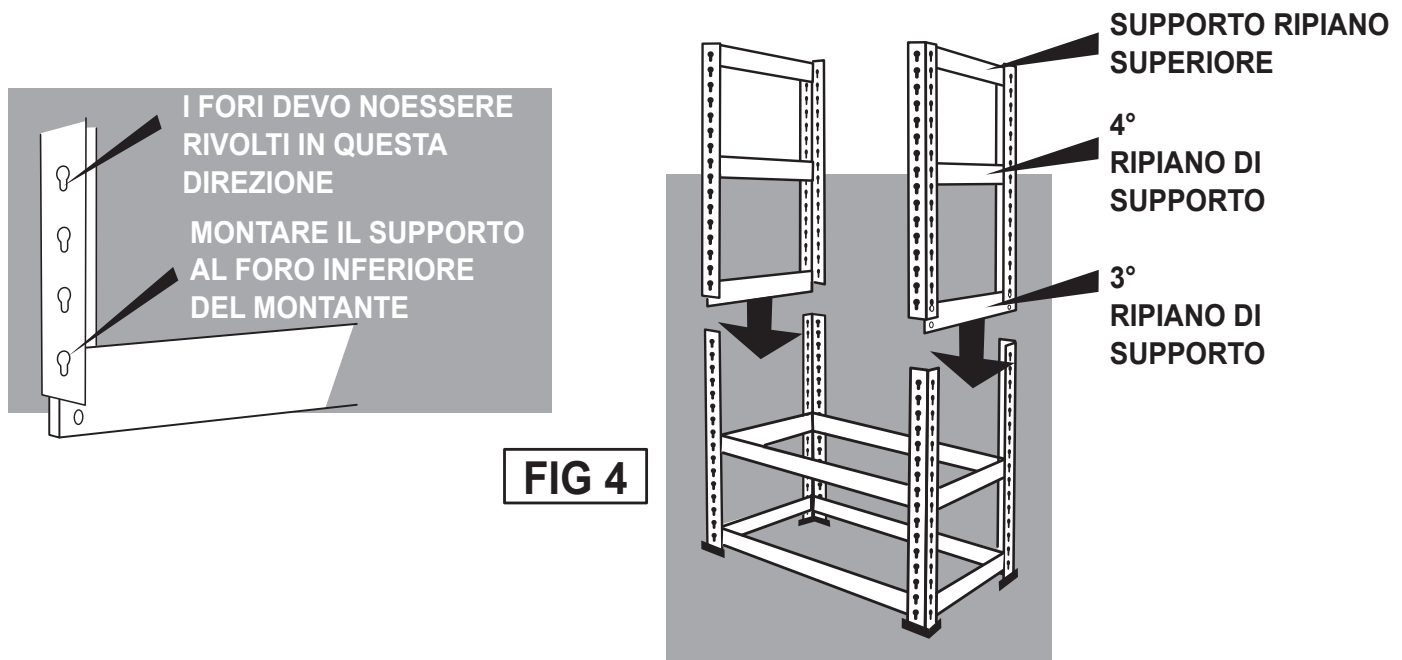

5. Per installare un lato della metà superiore per l'unità di stoccaggio:

Montare tre supporti ripiani corti, utilizzando due guide forate.

Montare prima il supporto superiore. Collocarlo nei primi due fori del binario. Quindi, inserire il quarto supporto e, infine, il terzo supporto nel foro inferiore del binario (figura 4).

Ripetere la procedura per installare l'altro lato.

Montare queste due metà superiori nella metà inferiore dell'unità (figura 4).

6. Montare i supporti per ripiani lunghi nei binari, utilizzando le posizioni del terzo e quarto ripiano superiore.

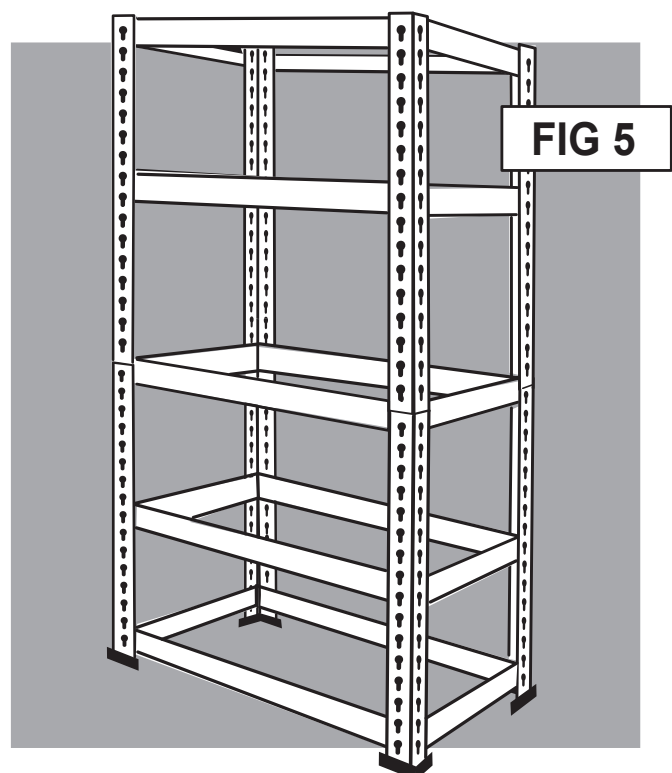

7. Posizionare cinque ripiani MDF su cinque supporti per ripiani: fissare i restanti quattro piedini in plastica sulla parte superiore dei binari forati (fig 6).

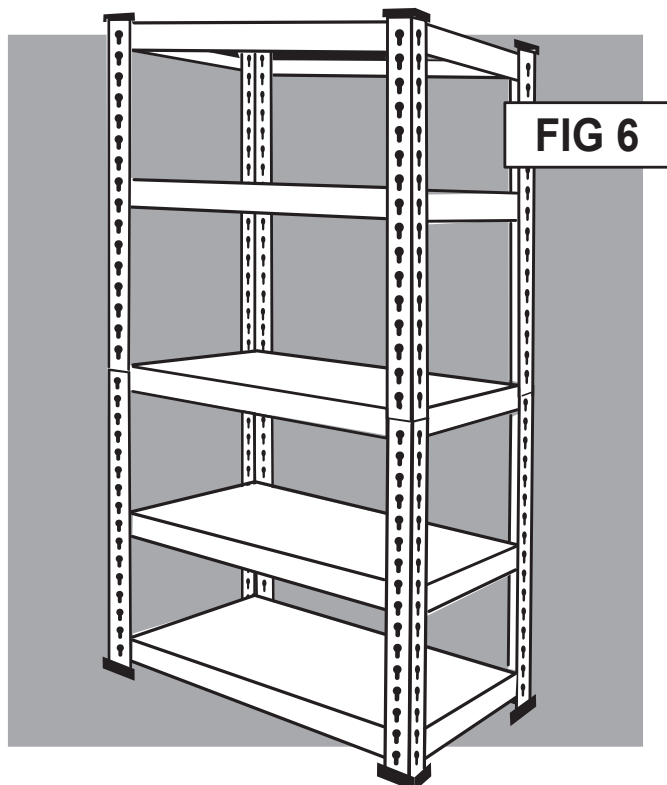

CONSIGLI SULLA POSIZIONE DEI RIPIANI

