



INcpb045_CA_IT

838-264V03

FOUR-LAYER MDF SHELF

EN

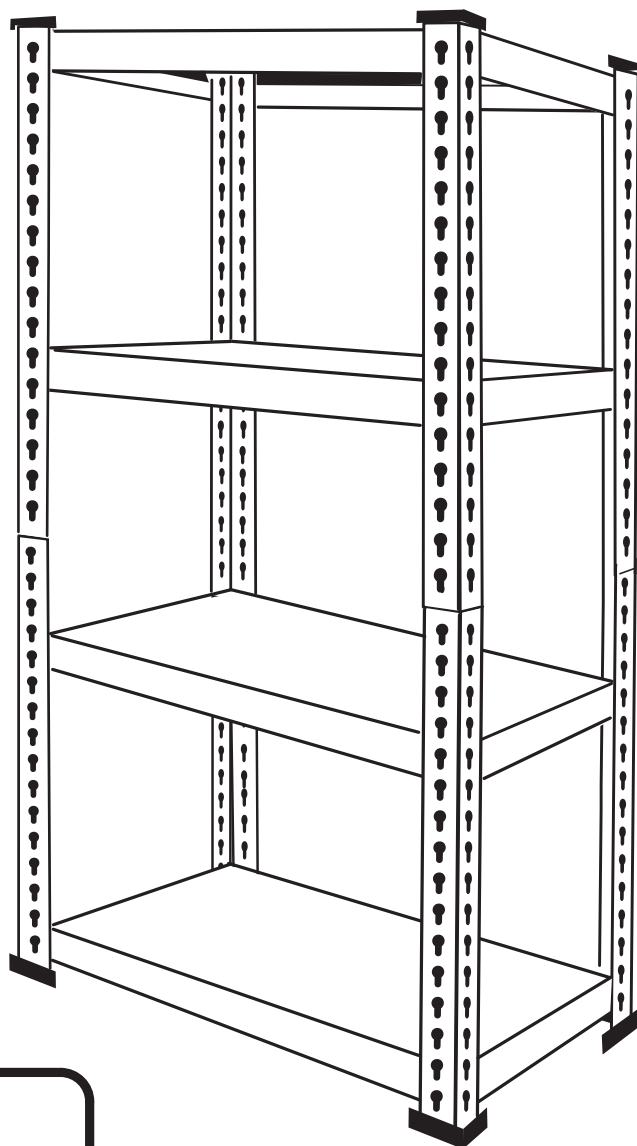

WARNING

Handle cut metal edges
carefully.

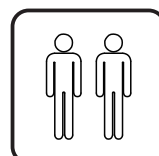

IMPORTANT, RETAIN FOR FUTURE REFERENCE: READ CAREFULLY

ASSEMBLY INSTRUCTION

The only tools required is a soft face or rubber mallet

LIST OF PARTS

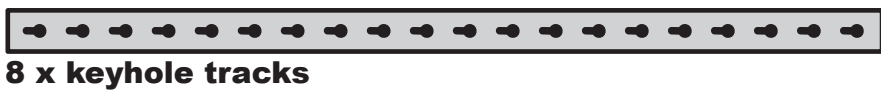

1. Get four keyhole tracks and attach plastic feet onto the ends. Ensure keyholes are the correct way up.

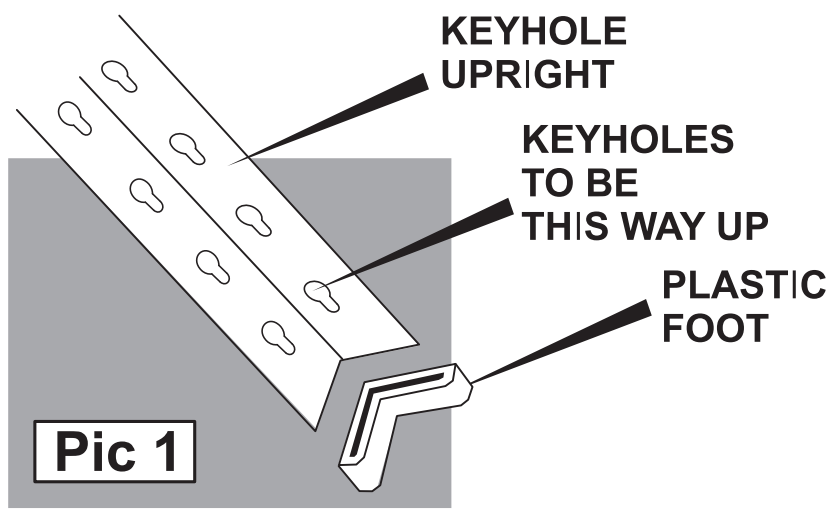

2. Using four keyhole tracks, fit two short and two long shelf supports into the bottom keyholes (for maximum strength) by slotting the pins in the supports into the keyholes of the tracks – tap firmly with a mallet to secure in place (pic 2).

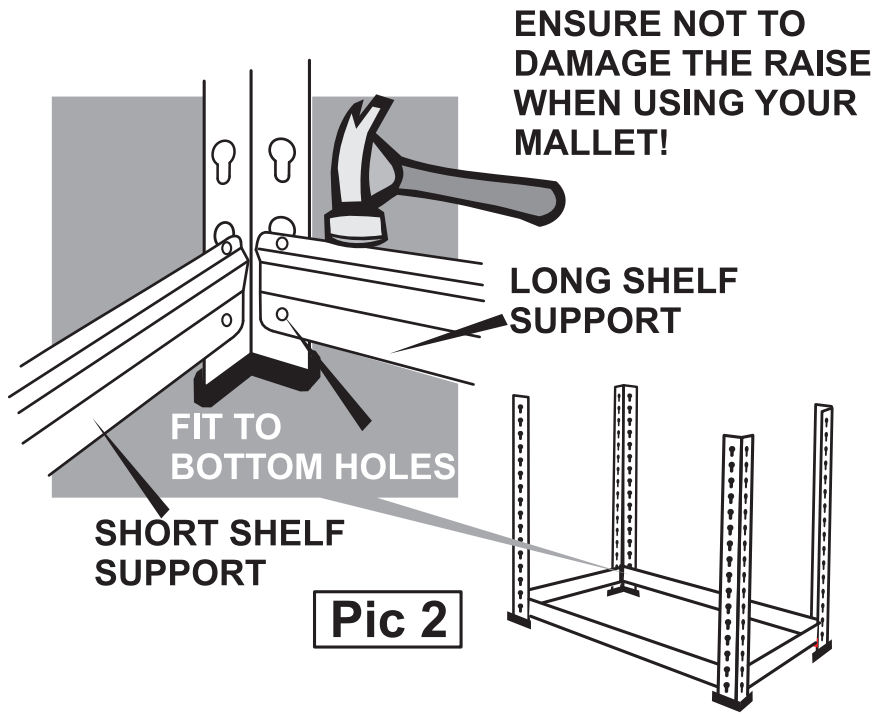

3. Fit long and short shelf supports to your desired position. Do not place these supports into the top two keyholes (pic 3).

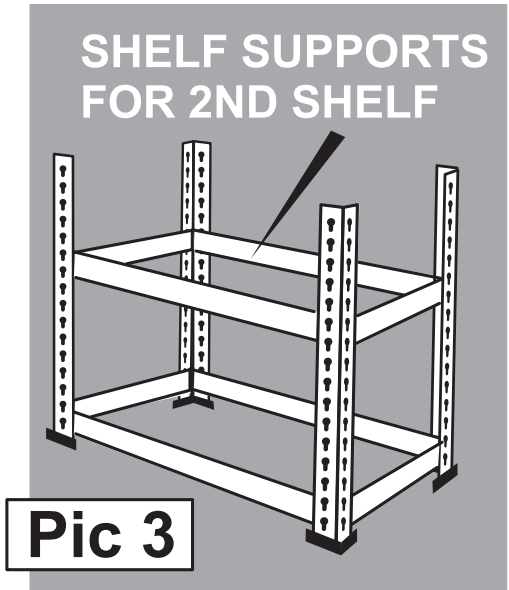

4. Connect two keyhole tracks by inserting the leg joiner. Use the mallet to ensure they are secured together. Repeat until all four tracks are built (pic 4).

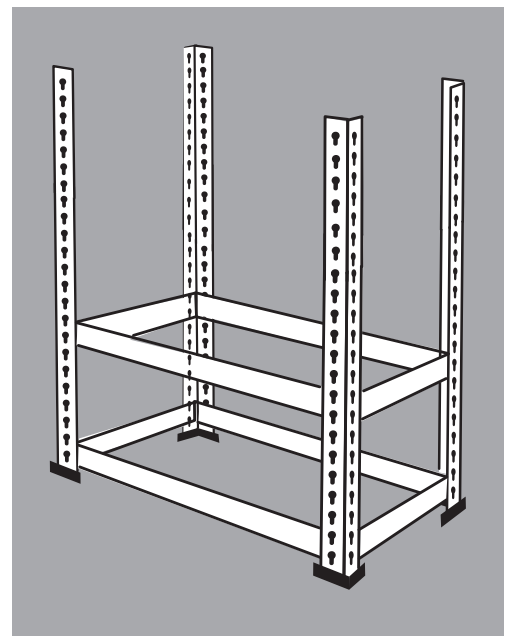
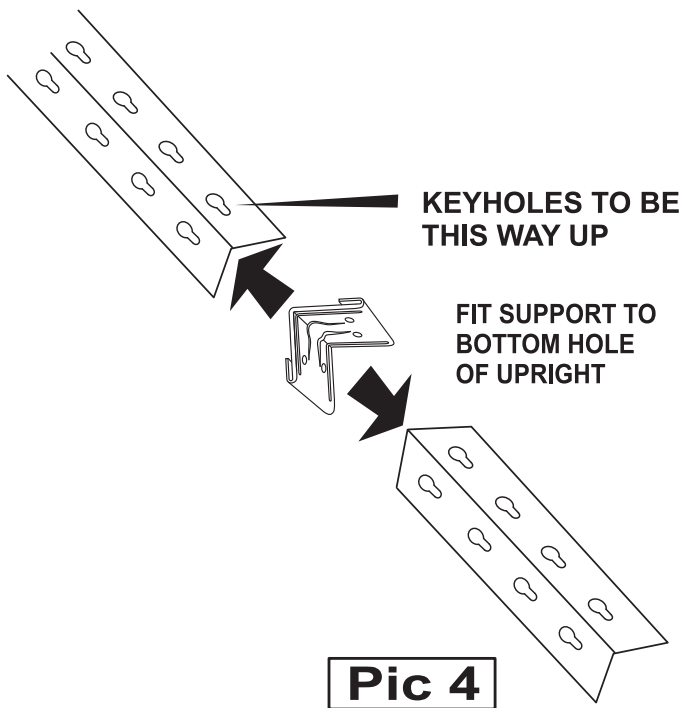

5. Fit long and short shelf supports into the keyhole tracks, using the third and top shelf positions (pic 5).

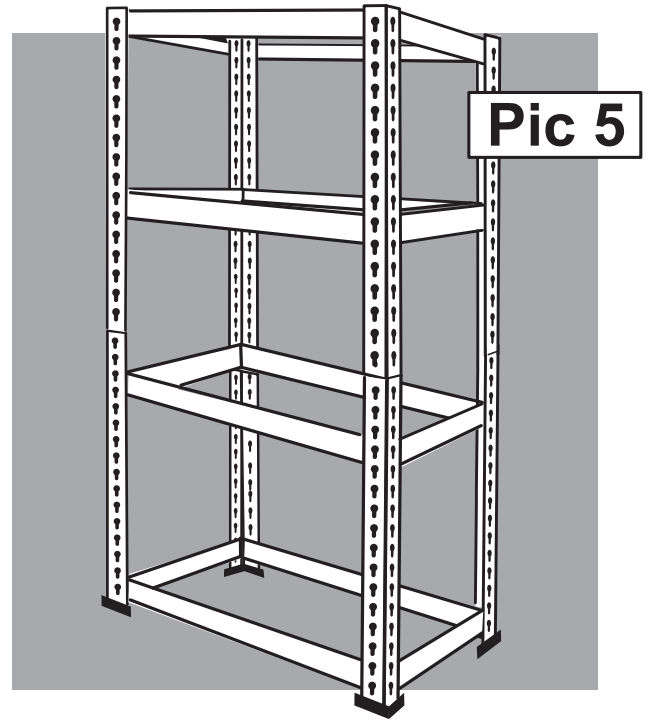

6. Place the four MDF shelves onto the four shelf supports – fit the last four plastic feet onto the top of the tracks (pic 6).

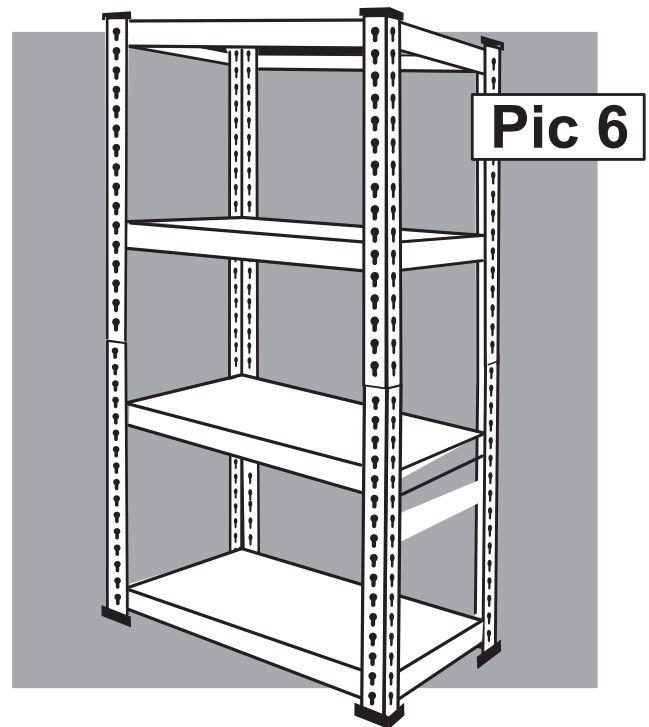

SHELF POSITION RECOMMENDATIONS

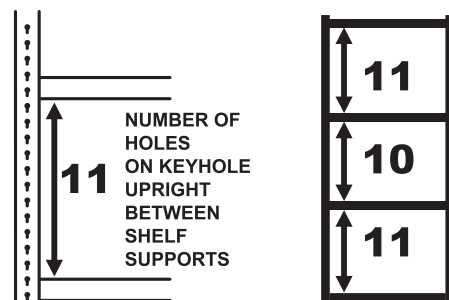

ETAGÈRE EN MDF À QUATRE NIVEAUX

FR

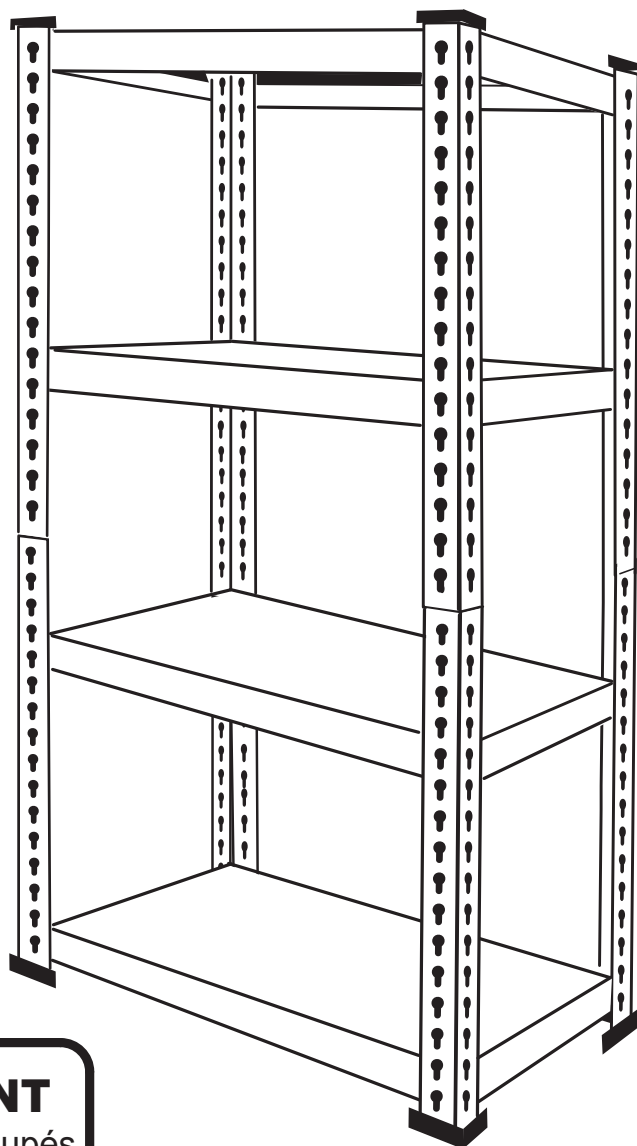

AVERTISSEMENT

Manipulez les angles coupés du métal avec précaution.

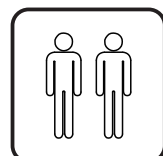

IMPORTANT - CONSERVEZ CES INFORMATIONS POUR VOTRE CONSULTATION ULTÉRIEURE: LISEZ ATTENTIVEMENT

INSTRUCTIONS D'ASSEMBLAGE

Le seul outil dont vous aurez besoin est un MAILLET

LISTE DES PIÈCES



1. Prenez quatre rails à trous de serrure et montez les embouts en plastique aux extrémités. Assurez-vous que les trous de serrure sont orientés dans le bon sens.

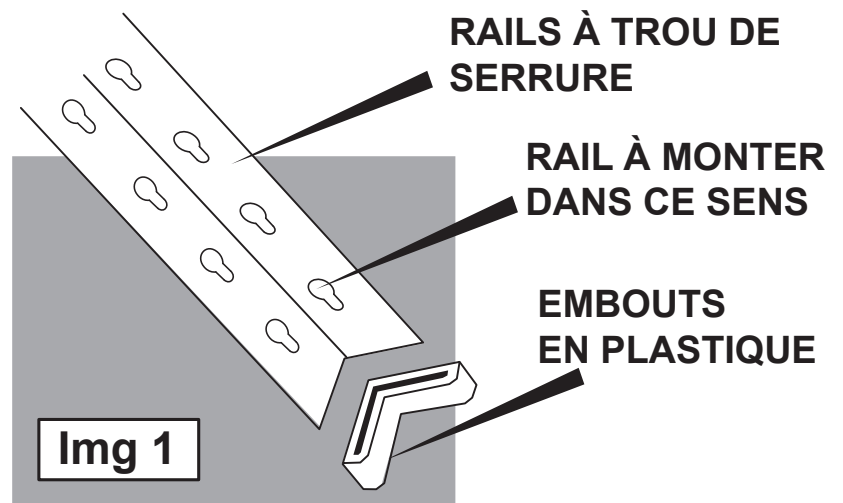

2. À l'aide de quatre rails à trous de serrure, placer deux supports d'étagère courts et deux supports d'étagère longs dans les trous de serrure inférieurs (pour une résistance maximale) en insérant les goupilles des supports dans les trous de serrure des rails - taper fermement avec un maillet pour les fixer en place (image 2).

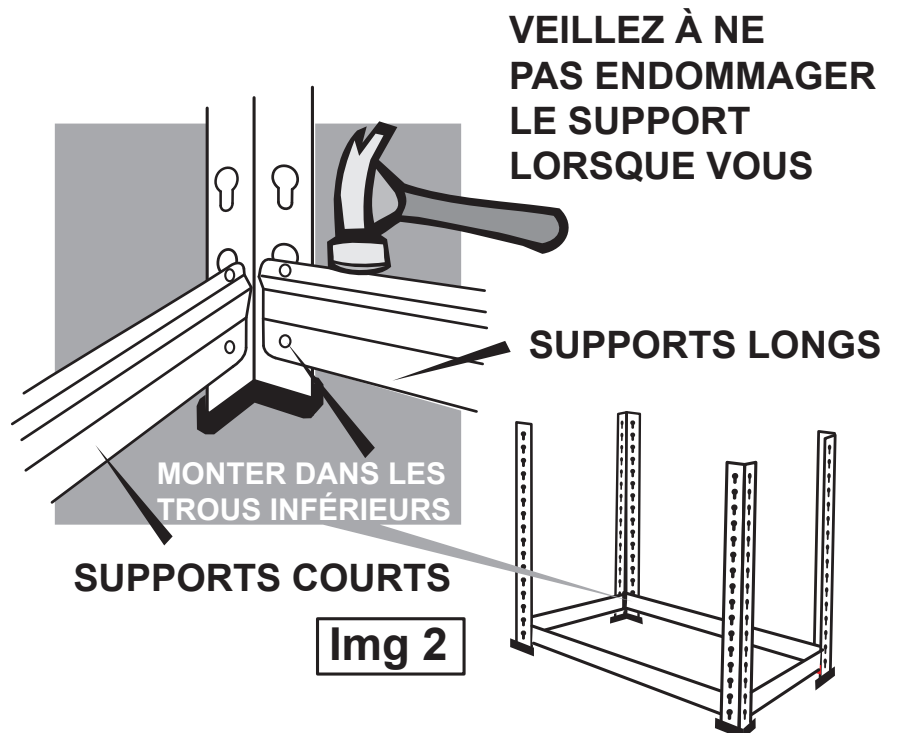

3. Installez les supports d'étagères longs et courts dans la position souhaitée. Ne les placez pas dans les deux trous de serrure supérieurs (image 3)

SUPPORTS D'ÉTAGÈRE
POUR LA 2E TABLETTE

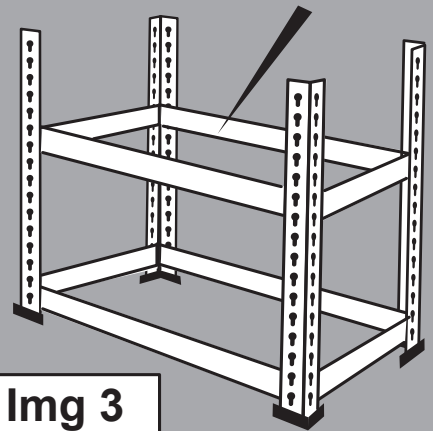

Img 3

4. Connectez deux rails en trou de serrure en insérant le joint de pied. Utilisez le maillet pour vous assurer qu'ils sont bien fixés ensemble. Répétez l'opération jusqu'à ce que les quatre rails soient posés (image 4).

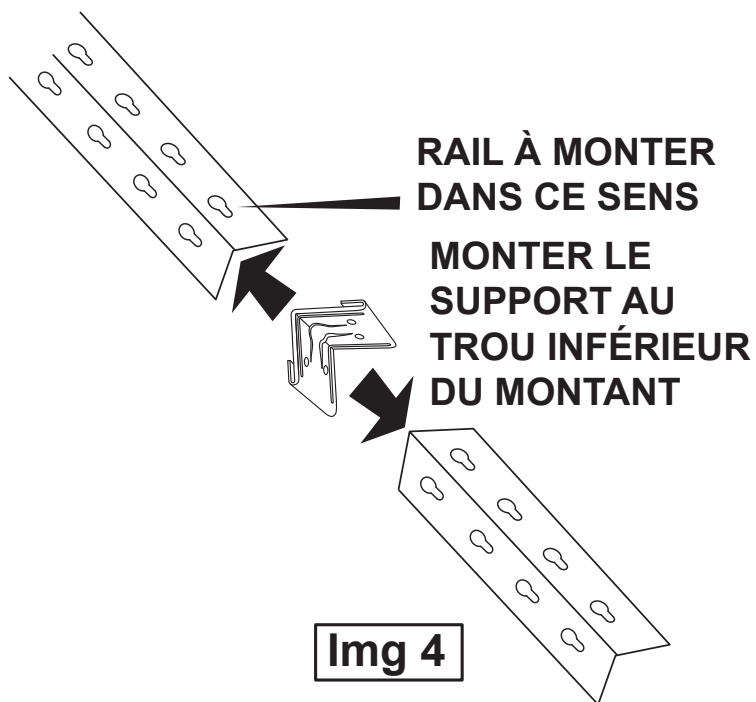

Img 4

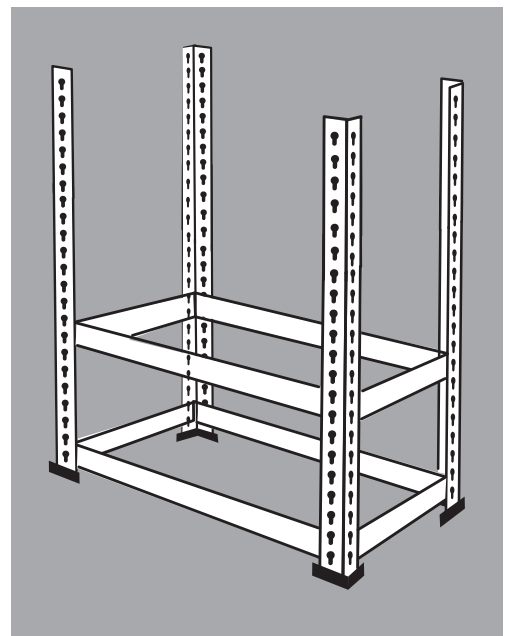

5. Monter les supports d'étagères longs et courts dans les rails en trou de serrure en prenant les positions des troisième et dernière tablettes (image 5).

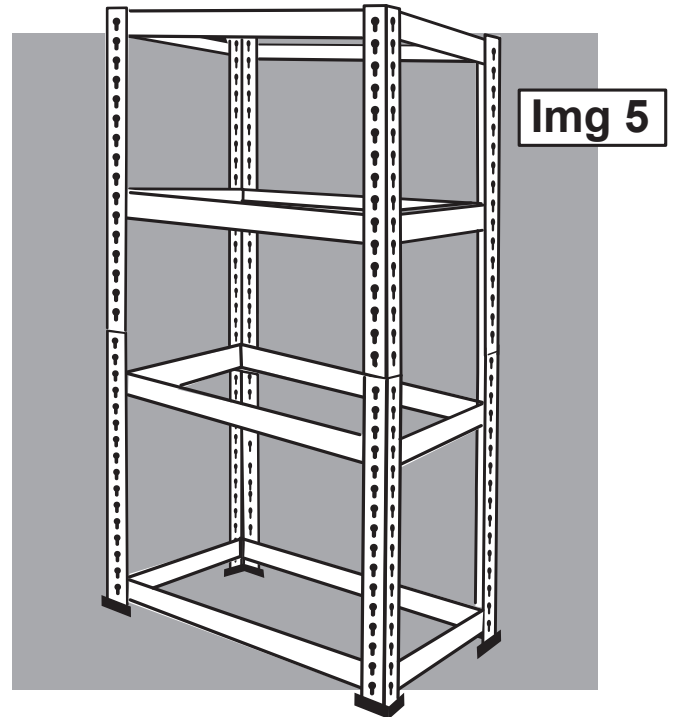

6. Placez les quatre tablettes en MDF sur les quatre supports d'étagères - montez ensuite les quatre derniers embouts en plastique sur le haut des rails (image 6).

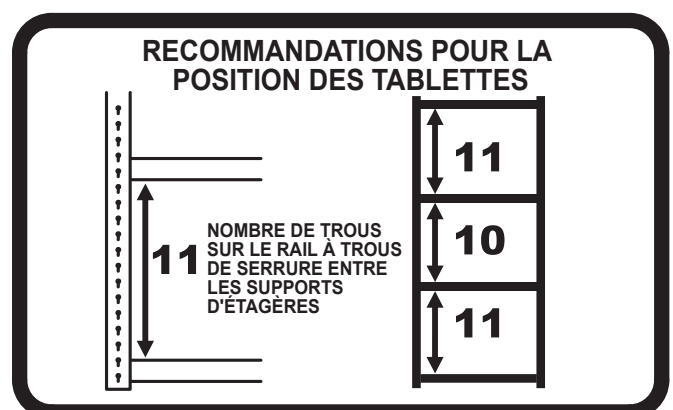
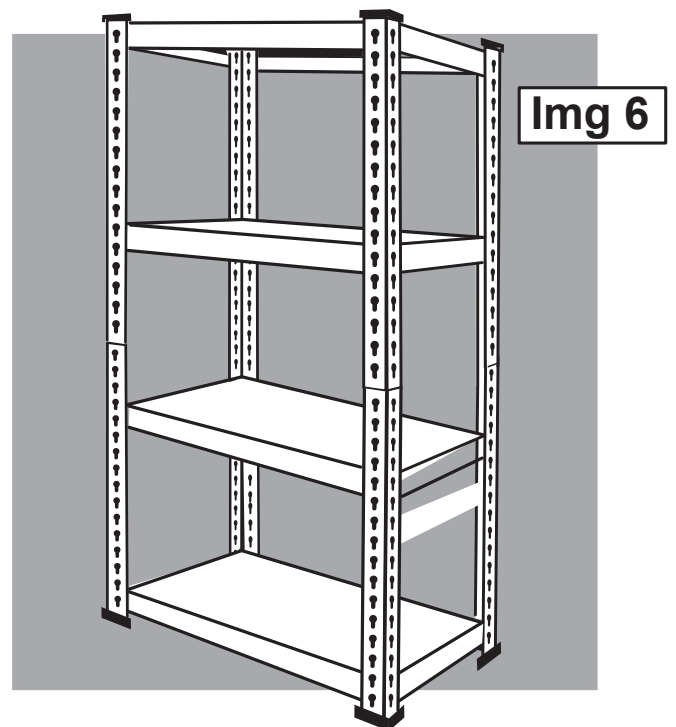

SCAFFALATURA A QUATTRO RIPIANI MDF

IT

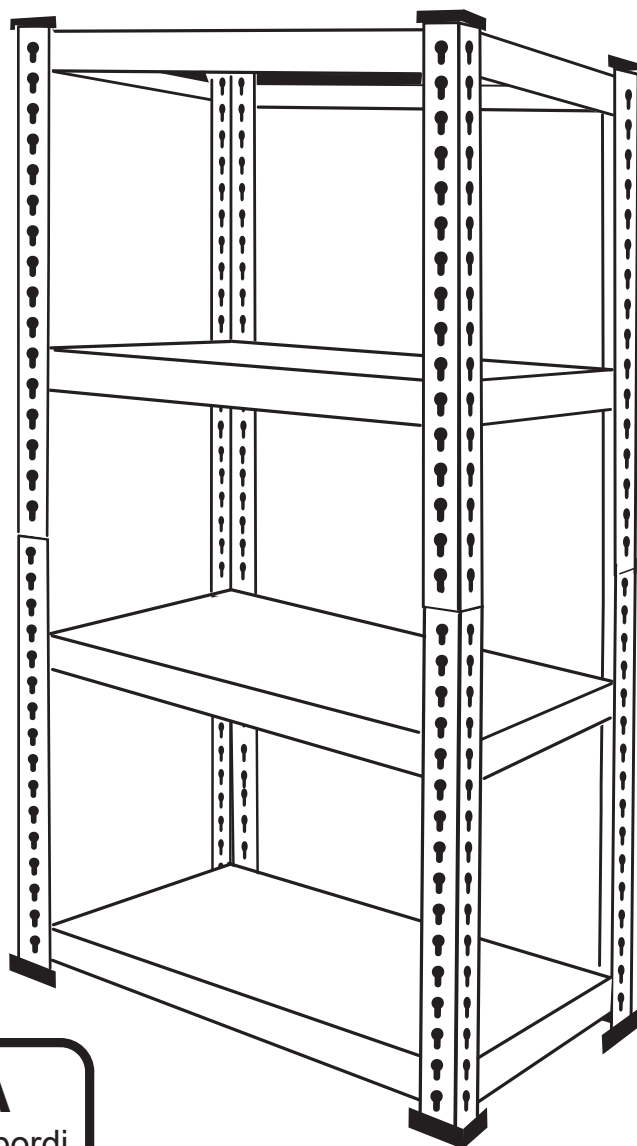
**AVVERTENZA**

Maneggiare con cura i bordi
di metallo taglienti

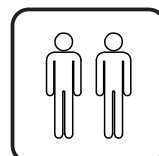

IMPORTANTE - CONSERVARE QUESTE INFORMAZIONI PER
CONSULTARLE IN SEGUITO: LEGGERE ATTENTAMENTE

ISTRUZIONI DI ASSEMBLAGGIO

Gli unici utensili necessari al montaggio sono una superficie morbida o un martello di gomma

LISTA PARTI

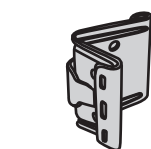

4* Raccordi per gambe



4* 9mm ripiani MDF



8* Binari forati



8* Piedini in plastica



8* Supporti ripiani lunghi



8* Supporti ripiani corti

1. Prendere quattro binari forati e fissare i piedini in plastica alle estremità. Assicurati che i fori siano allineati nel modo corretto.

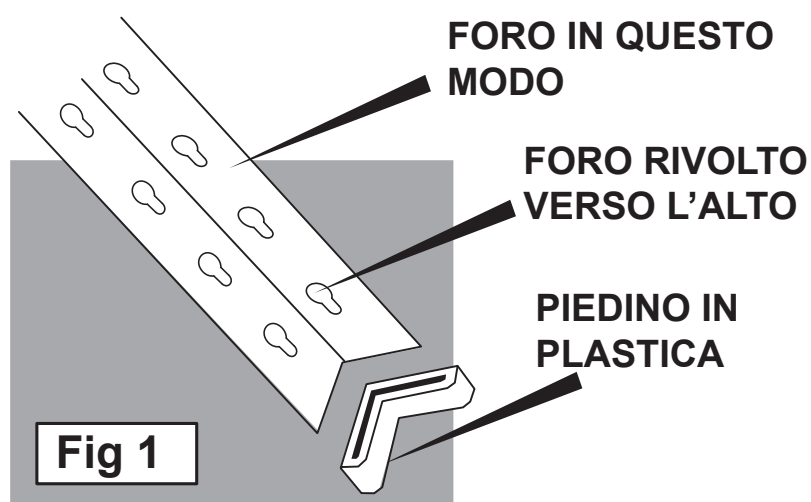

2. Prendere quattro binari forati, inserire due supporti per ripiani corti e due lunghi nei fori inferiori (per ottenere la massima resistenza) inserire i perni nei fori presenti sui binari – picchiettare forte con un martello per fissarli in posizione (fig 2).

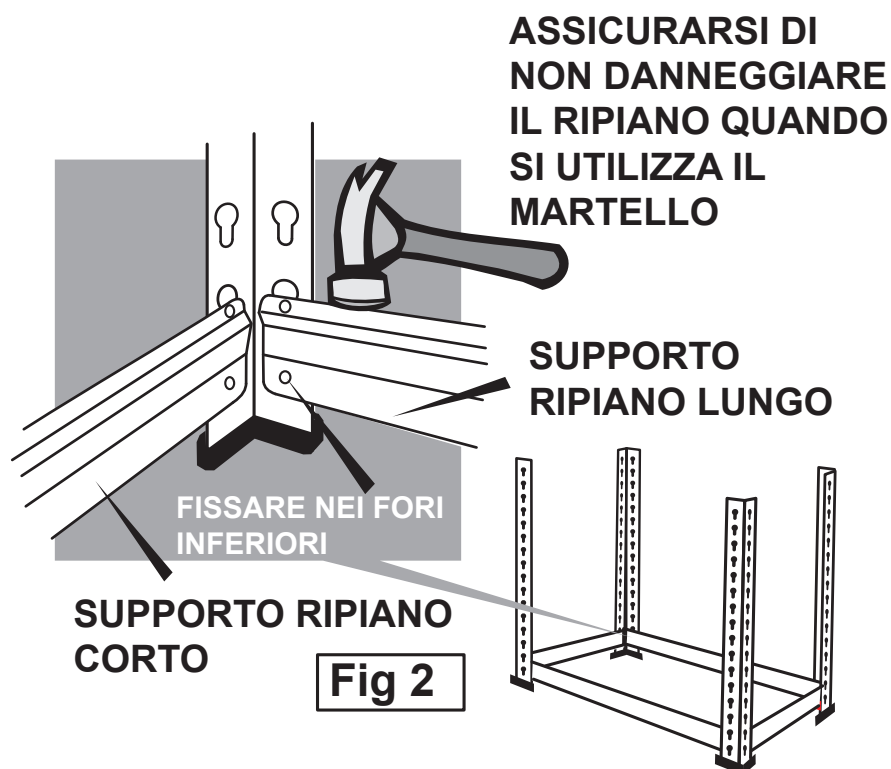

3. Montare i ripiani lunghi e corti in posizione desiderata. Non collocare questi supporti nei due fori superiori (fig 3).

SUPPORTI RIPIANO
PER IL 2DO RIPIANO

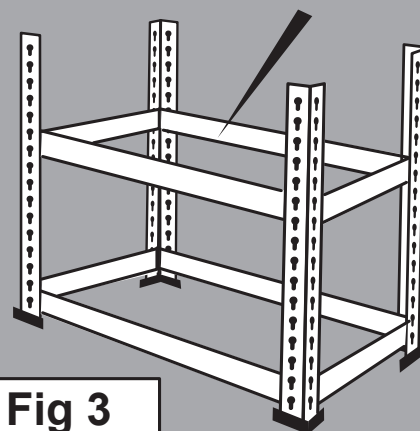

Fig 3

4. Collegare due binari forati con il raccordo per le gambe. Usare il martello per assicurarti che siano fissati saldamente insieme. Ripetere fino a quando tutti e quattro i binari non sono state montati (fig 4).

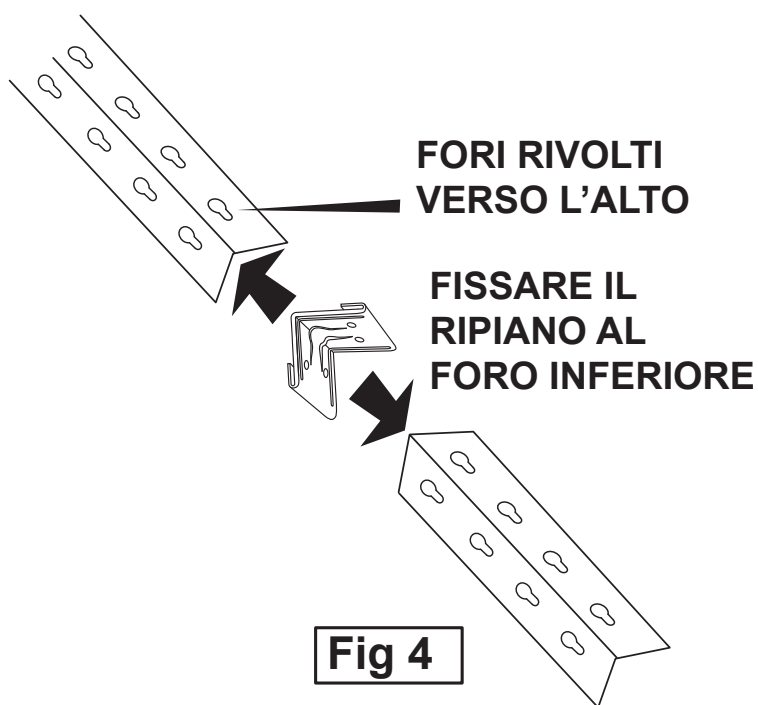
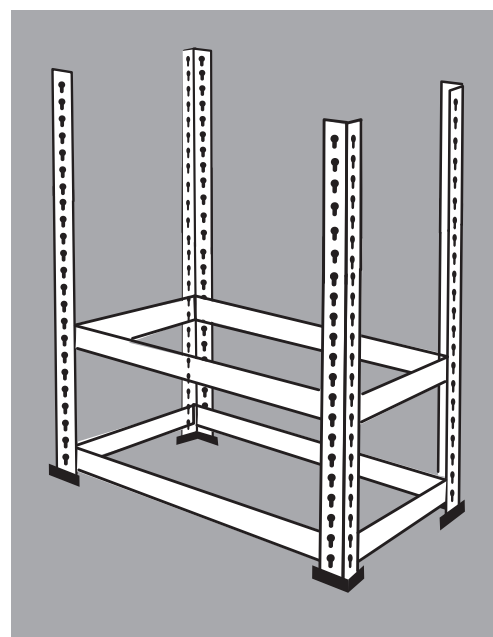

Fig 4



5. Montare i supporti per ripiano lunghi e corti nei binari forati, questa volta nelle posizioni del terzo ripiano e del ripiano superiore (fig 5).

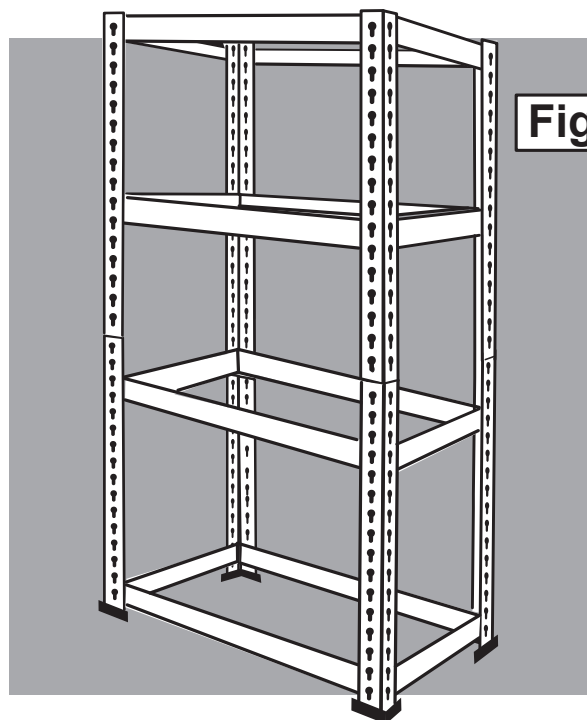

Fig 5

6. Posizionare i quattro ripiani in MDF sui quattro supporti per ripiani - montare gli ultimi quattro piedini in plastica sulla parte superiore dei binari (fig 6).

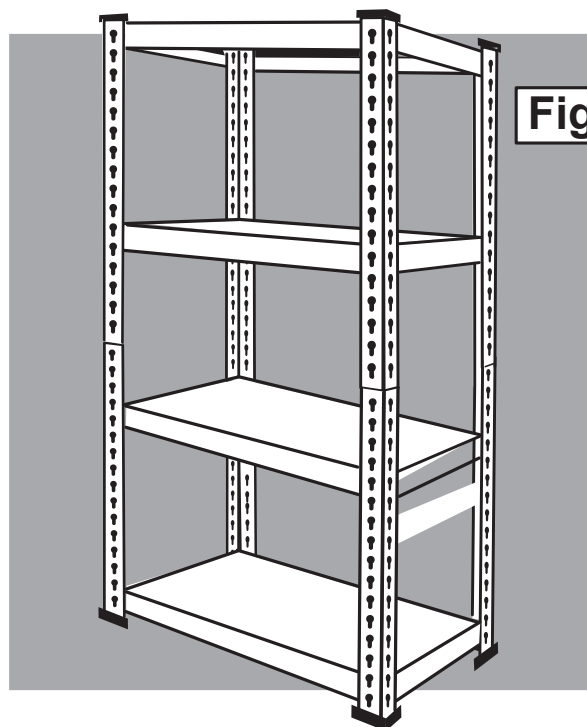

Fig 6

CONSIGLI SULLA POSIZIONE DEI RIPIANI



NUMERO DI FORI POSIZIONATI TRA RIPIANO E SUPPORTI