

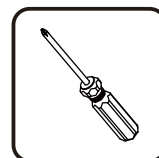

INcqc073_GL

836-417

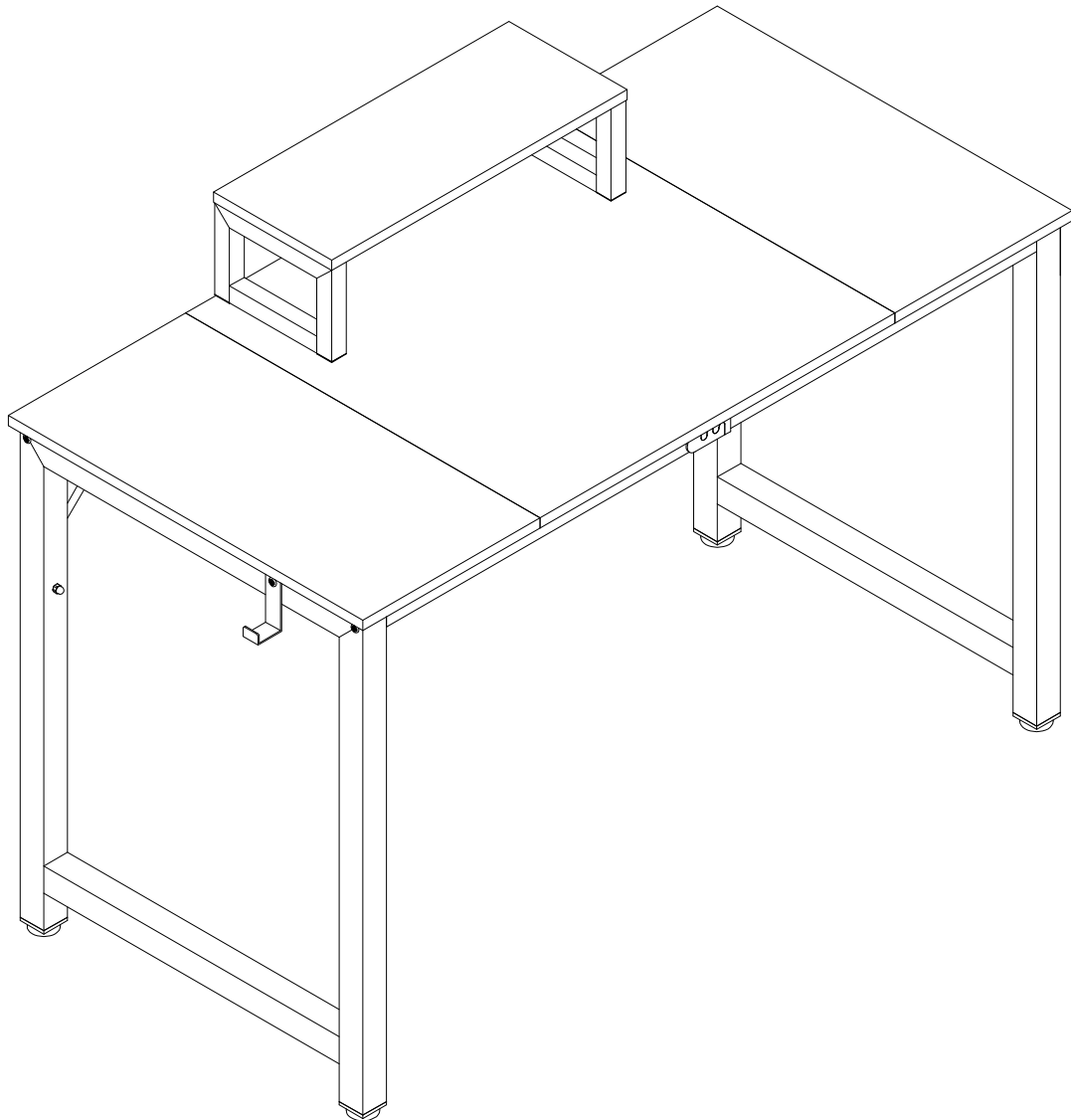

IMPORTANT, RETAIN FOR FUTURE REFERENCE: READ CAREFULLY

Tools Recommended

ASSEMBLY & INSTRUCTION MANUAL

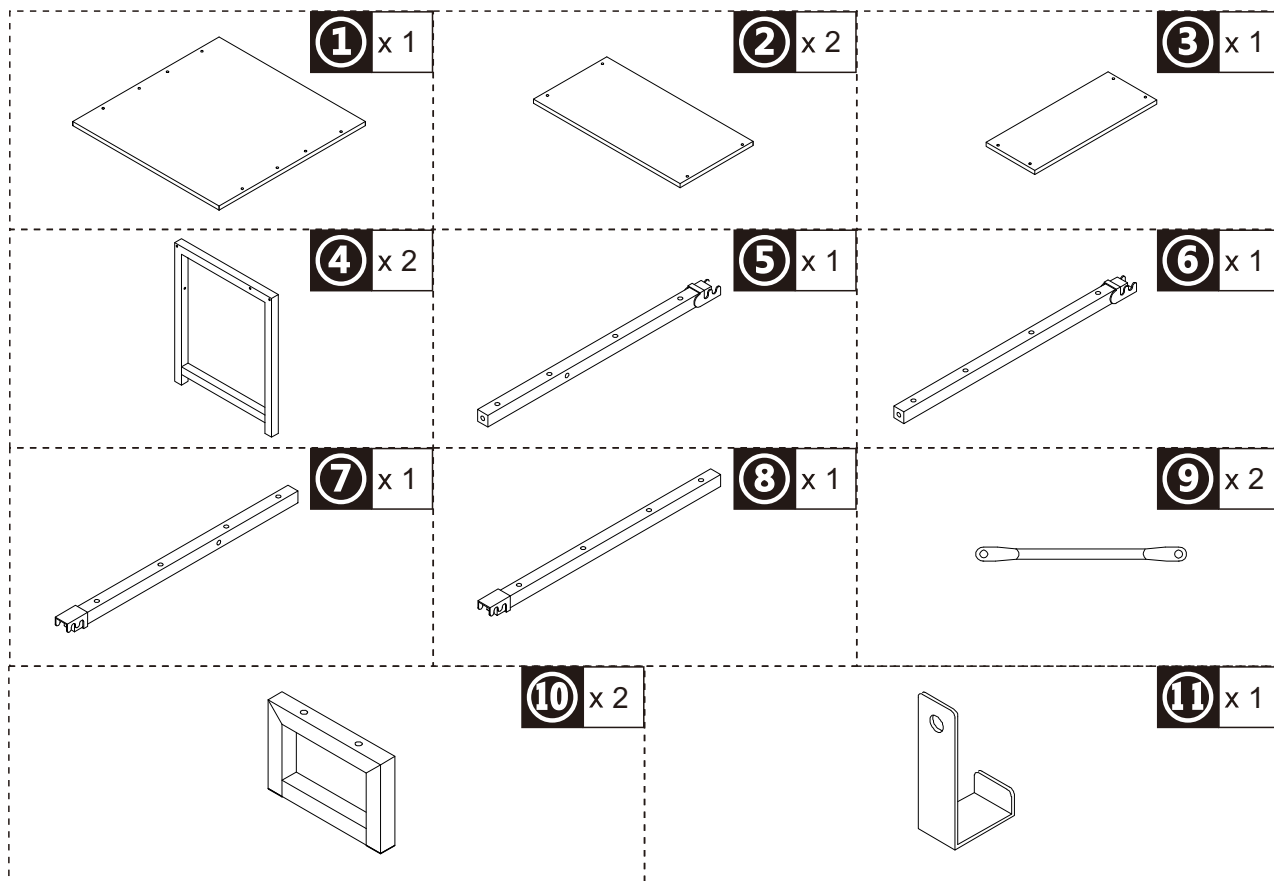
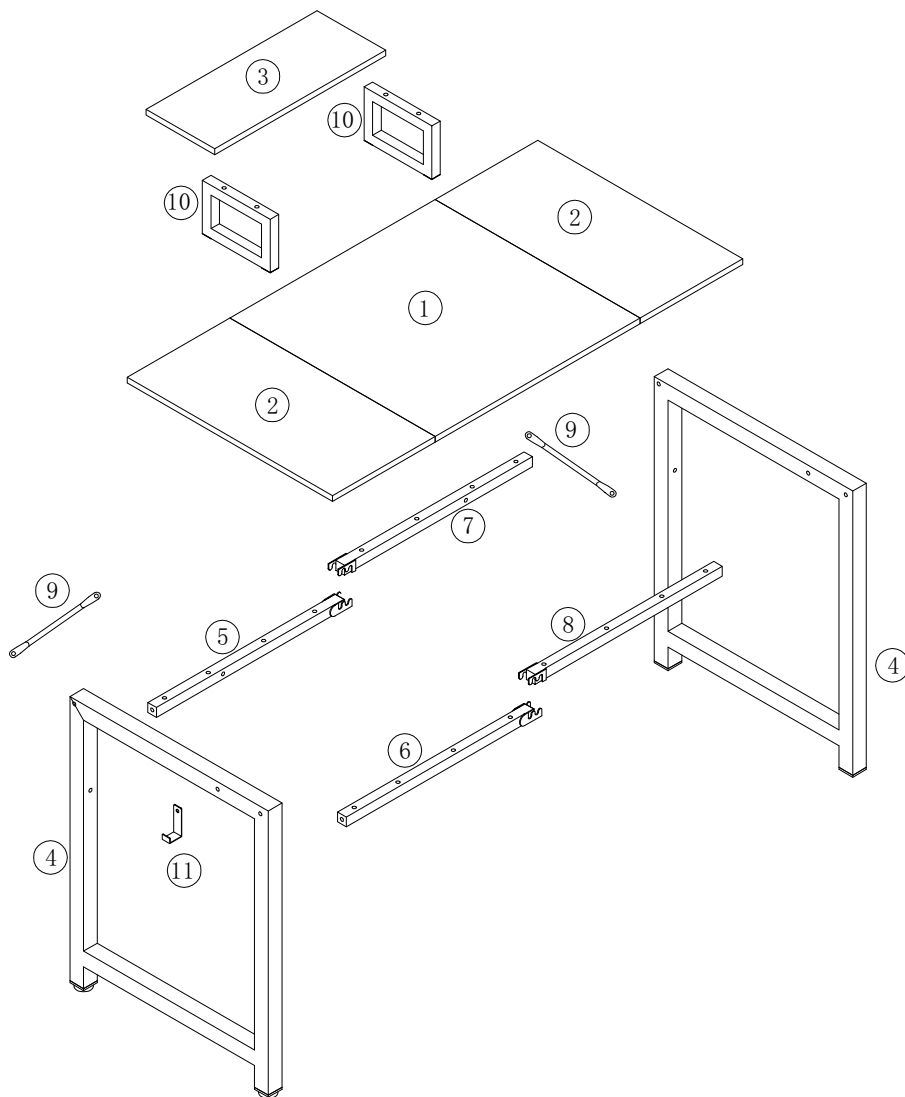

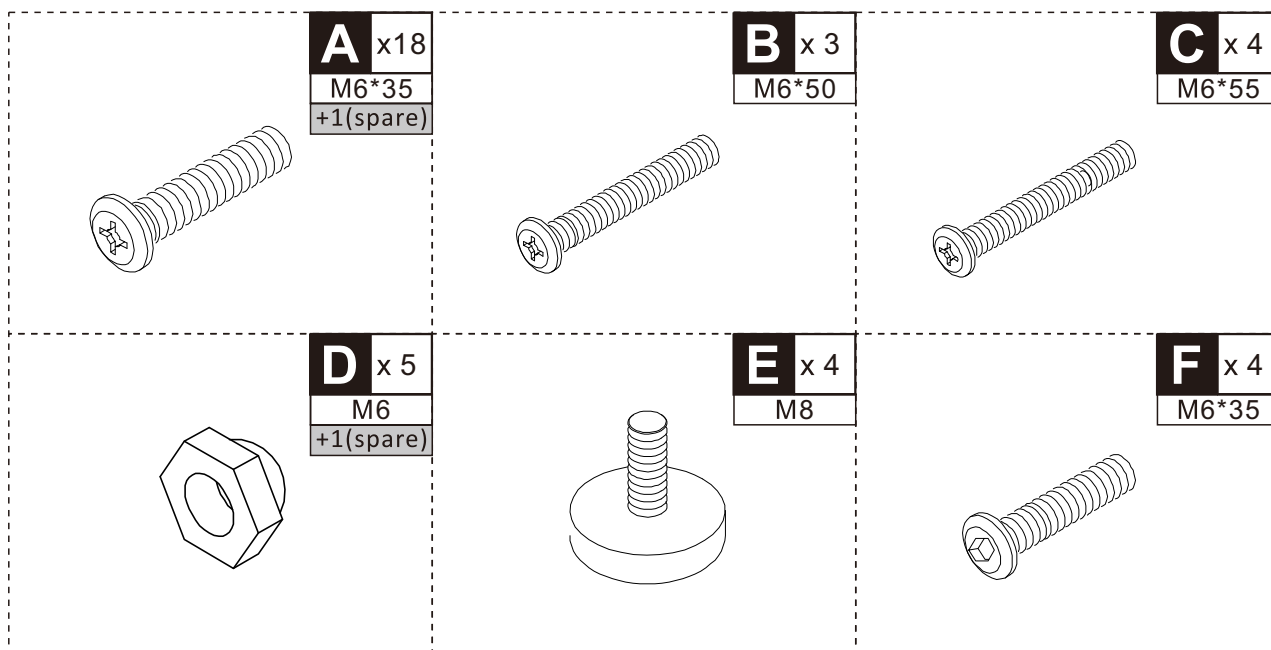

EN_Note : Do not tighten bolts fully until all parts are connected!



DE_Hinweis: Ziehen Sie die Schrauben erst fest an, wenn alle Teile verbunden sind!

IT_Nota: non serrare completamente i bulloni fino a tutte le parti non sono ancora collegate!



FR_Note : Ne serrez pas les boulons à fond tant que toutes les pièces ne sont pas connectées!

ES_Nota: No apriete los tornillos completamente hasta que todas las partes están conectadas!

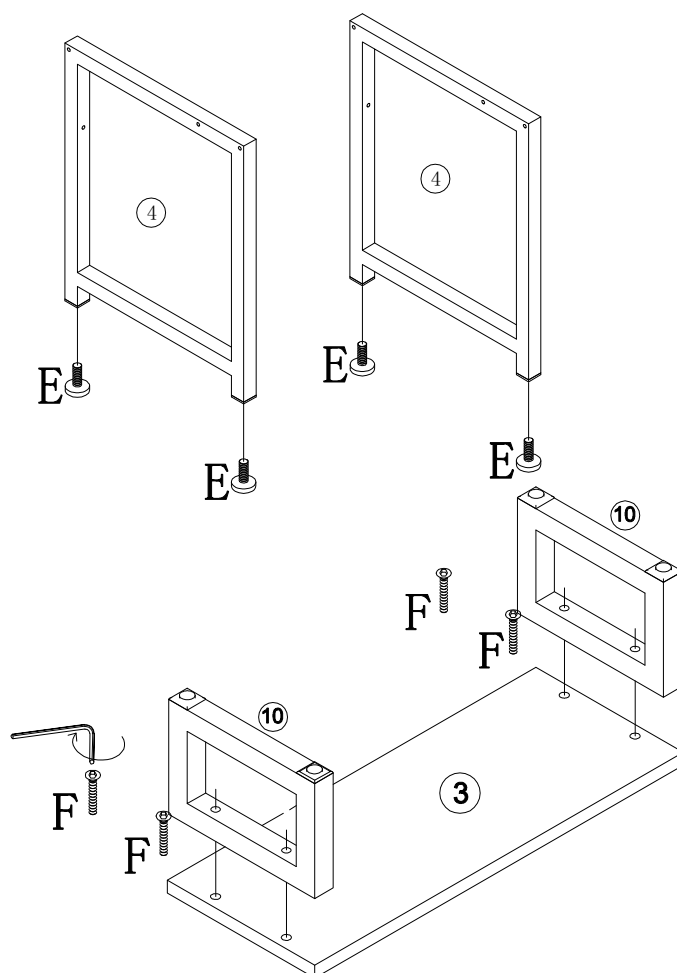

01

E	4PCS
	
	M8
F	4PCS
	
	M6*35

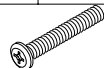

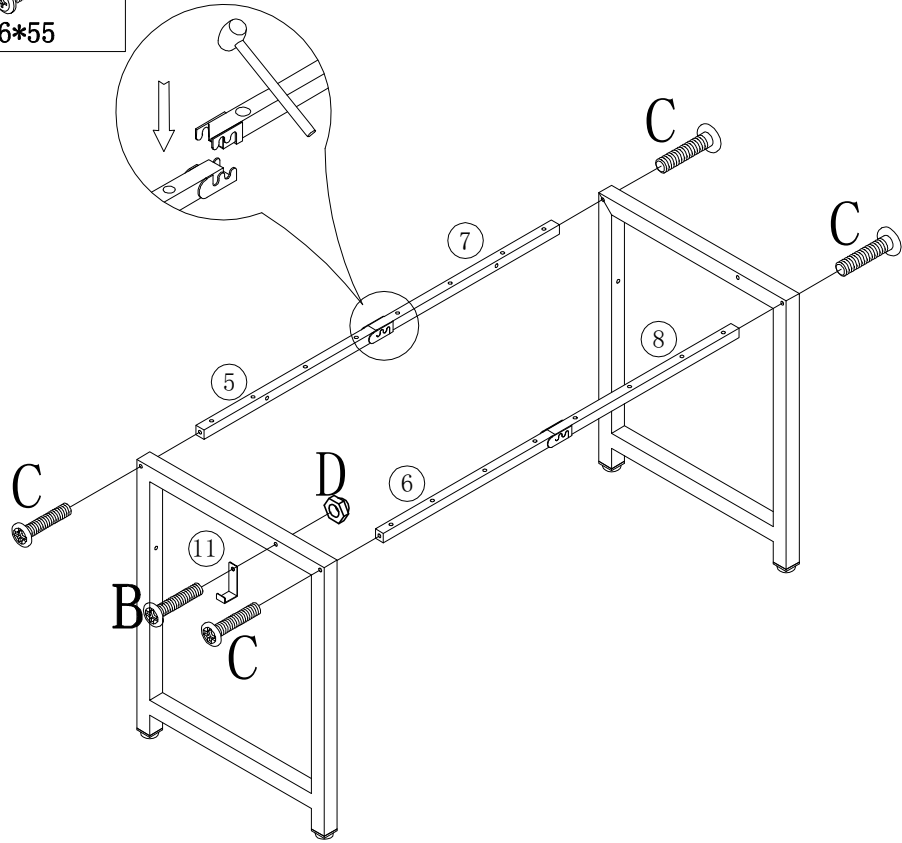
D	1PC	B	1PC	C	4PCS
					
M6		M6*50		M6*55	



A	2PCS
	
M6*35	
D	4PCS
	
M6	
B	2PCS
	
M6*50	

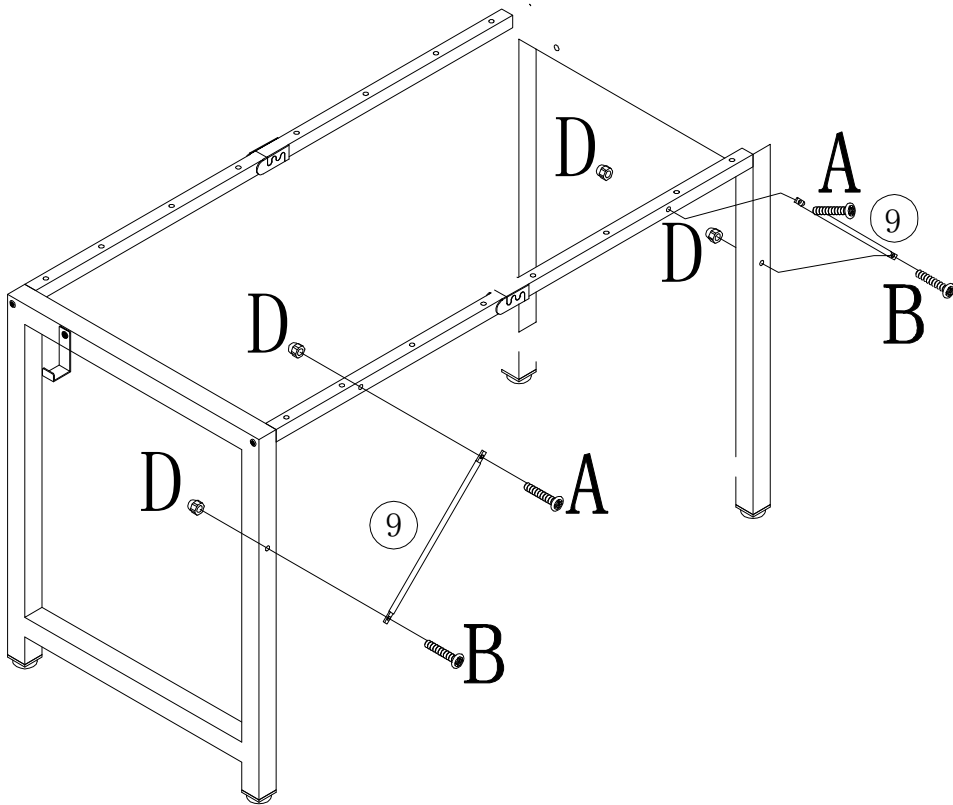

A 8PCS



M6*35

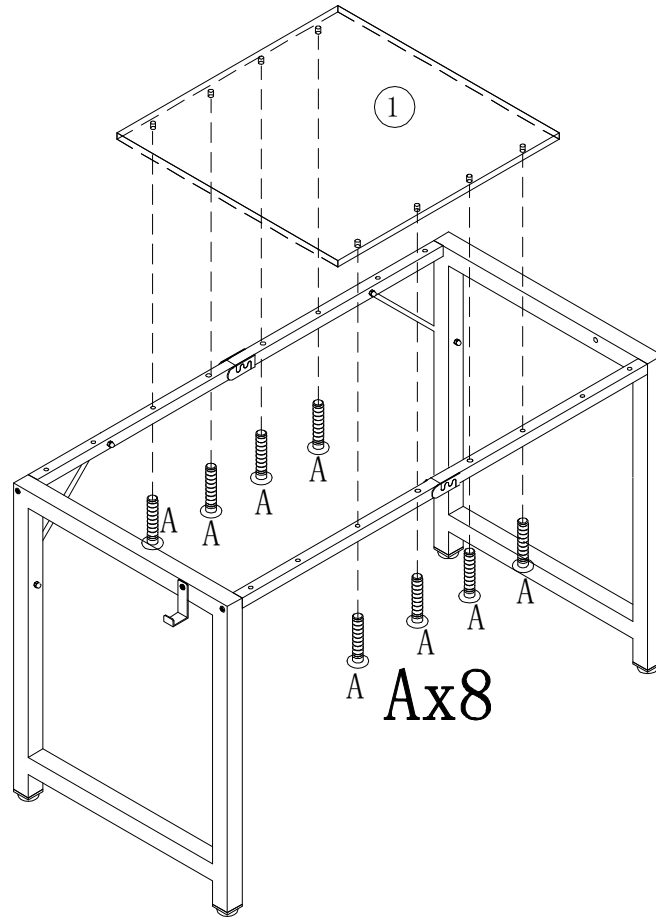

A 8PCS



M6*35

