

Food Dehydrator

User's manual

EN



Prior to using this appliance, please read the user's manual thoroughly, even in cases where you have previously familiarised yourself with the operation of similar types of appliances. Only use the appliance in the manner described in this user's manual. Keep this manual for future use.

We recommend saving the original shipping cardboard box, packaging material, receipt and warranty card for the duration of the warranty. During transportation, pack the appliance using the original packaging materials only.

CONTENTS

IMPORTANT SAFETY INSTRUCTIONS	3
IMPORTANT SAFETY INSTRUCTIONS	3
DESCRIPTION OF THE FOOD DEHYDRATOR	5
ADJUSTING THE HEIGHT BETWEEN THE TRAYS	5
PRINCIPLES OF DEHYDRATION	6
PROCEDURE	6
PRETREATING	6
RECONSTITUTING FOODS	7
DRYING	8
PACKING AND STORAGE.....	9
ROTATING THE TRAYS	9
REMEMBER	9
RECIPES	10
DRYING TABLE FOR FRUITS	11
DRYING TABLE FOR VEGETABLES	12
CLEANING AND MAINTENANCE	14
TECHNICAL SPECIFICATIONS	14
INSTRUCTIONS AND INFORMATION REGARDING THE DISPOSAL OF USED PACKAGING MATERIALS	15
DISPOSAL OF USED ELECTRICAL AND ELECTRONIC APPLIANCES	15

IMPORTANT SAFETY INSTRUCTIONS

- This appliance may be used by children 8 years of age and older and by persons with physical or mental impairments or by inexperienced persons, if they are properly supervised or have been informed about how to use of the product in a safe manner and understand the potential dangers. Do not allow children to play with the appliance. Cleaning and maintenance must not be performed by children unless they are older than 8 years of age and under supervision.
- Keep this appliance and the power cord out of reach of children younger than 8 years of age.

IMPORTANT SAFETY INSTRUCTIONS

With proper care, your Food Dehydrator designed to provide years of household service. Be sure to follow these basic precautions when using this electrical appliance. Read all instructions before using.

- Do not touch heating coil.
- Do not touch hot surfaces.
- To protect against electrical hazards do not immerse cord, plugs, or the base assembly in water or other liquid.
- Close supervision is necessary when any appliance is used by or near children.
- Unplug from outlet when not in use and before cleaning. Allow to cool before putting on or taking off parts.

Food Dehydrator

- Do not plug in dehydrator while top is inverted (storage position) and do not invert top into bottom for storage until unit has completely cooled down.
- Do not operate any appliance with a damaged cord or plug or after the appliance malfunctions, or has been damaged in any manner. Return appliance to the nearest authorized service facility for examination, repair, or adjustment.
- The use of accessory attachments not recommended by the appliance manufacturer may cause hazards.
- Do not plug in outdoors.
- Do not place on or near a hot gas or electric burner, or in a heated oven.
- Do not pour liquids in the dehydrator.
- Do not use appliance for other than intended use.
- Do not let cord hang over edge of table or counter, or touch hot surfaces.
- Do not use this appliance in case the electric cord or plug is damaged, in case it does not function correctly, if it is damaged or has been dropped on the ground. Provided the electric cord is damaged, it must be replaced by an authorised service centre or other similar qualified person in order to prevent a dangerous situation from occurring.



Note:

This appliance is not designed to be controlled using a programmed device, external timer switch or remote control.

**FOR HOUSEHOLD USE ONLY!
DO NOT WASH IN AUTOMATIC DISHWASHER!**

DESCRIPTION OF THE FOOD DEHYDRATOR

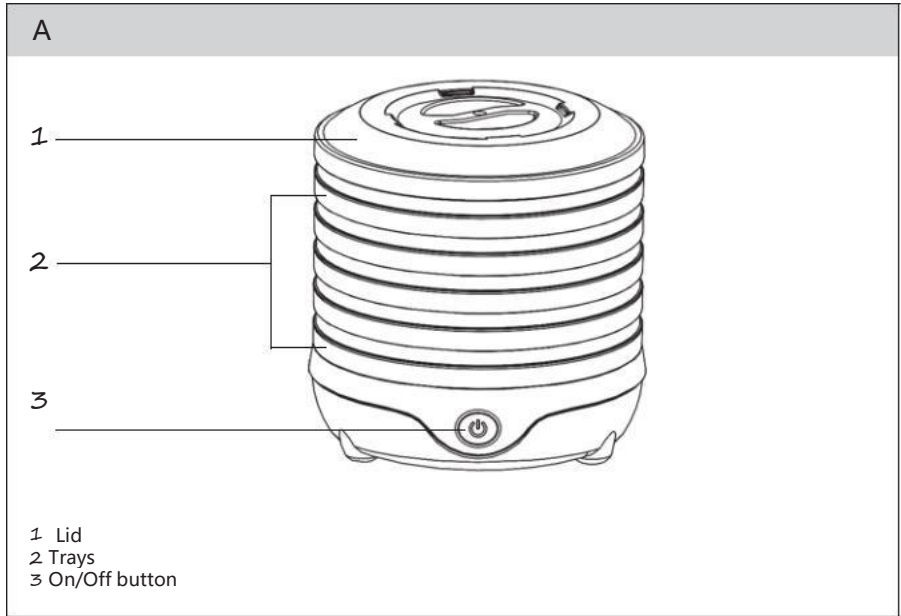

ADJUSTING THE HEIGHT BETWEEN THE TRAYS

The food dehydrator offers two options for setting tray heights. To set the lower (default) height of 1.5 cm, place the trays on top of each other as shown in B1. Turn the trays so that the tabs located at the bottom of the trays are placed adjacent to the grooves, located at the top of every tray. To set a clearance of 2.8 cm, turn and seat the trays so that the tabs fit precisely in to the grooves as shown in B2.

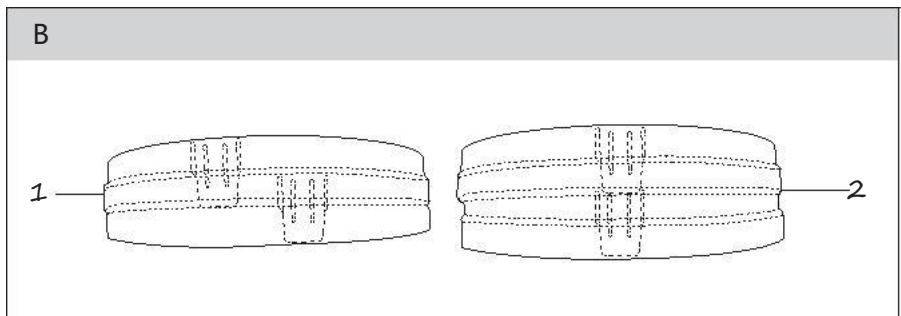

PRINCIPLES OF DEHYDRATION

There are no absolutes and quite a few variables in food dehydration. The best way to become proficient is to experiment using this booklet as a guideline and then adjusting your drying technique according to your results.

Record keeping is helpful in food dehydration. Records of weight of produce before and after the dehydration, length of time required for drying, etc., can be useful information in attaining a good quality product. Information can be recorded on the labels of the food storage containers.

Tasty ready-to-eat snacks and confections are some of the versatile products you can create by drying fruits and vegetables at home. After soaking in water, the re-hydrated foods can be used in favorite recipes for casseroles, soups, stews and salads. Re-hydrated fruits and berries can also make excellent compotes or sauces.

Drying is appealing because the procedure is relatively simple and requires little equipment. Only minimal storage space is needed.

Dehydrating is a method of heating the food to evaporate the moisture present, and removing the water vapor formed.

Most food products release moisture rapidly during early stages of drying. This means they can absorb large amounts of heat and give off large quantities of water vapor while remaining at a temperature well below that of the drying air.

PROCEDURE

Fruits and vegetables selected for drying should be the highest quality obtainable – fresh and fully ripened. Wilted or inferior produce will not make a satisfactory dried product. Immature produce lacks flavor and color. Overmature produce may be tough and fibrous or soft and mushy.

Prepare produce immediately after gathering, and begin drying at once. Wash or clean all fresh food thoroughly to remove any dirt or spray. Sort and discard defective food; decay, bruises, or mold on any piece may affect an entire batch.

For greater convenience when you finally use the food, and to speed drying, it is advisable to peel, pit, or core some fruits and vegetables. Smaller pieces dry more quickly and uniformly.

PRETREATING

Enzymes in fruit and vegetables are responsible for color and flavor changes during ripening. These changes will continue during drying and storage unless the produce is pretreated to slow down enzyme activity.

Blanching can be used in the pretreatment of vegetables, as it helps set color and hastens drying by relaxing tissues. Blanching may also prevent undesirable changes in flavor during storage, and improve reconstitution during cooking.

Many light-colored fruits (especially apples, apricots, peaches, nectarines, and pears) tend to darken during drying and storage. To prevent this darkening, the fruit may be pretreated by blanching or by a suitable dip, but effectiveness of pretreatment methods varies.

Fruit may be dipped in one of the following:

- Pineapple or lemon juice as a natural alternative to other pretreatments to reduce browning. Slice fruit directly into juice. Remove promptly (about 2 minutes) and place on trays. Fruits may also be dipped in honey, spices, lime or orange juice, or sprinkled with coconut to give them a snappy dried flavor. Use your imagination and make your own flavorful dip.
- Sodium Bisulfite: Ask for food safe, (USP) grade only. Dissolve 1 teaspoon of sodium bisulfite in one quart of water. Prepare small amounts of fruit and dip for 2 minutes in the solution. This helps prevent loss of Vitamin C and maintains a bright color. Sodium bisulfite may be obtained from a local pharmacy.
- A solution of table salt.
- A solution of ascorbic acid or citric acid. Commercial antioxidant mixtures containing ascorbic acid may also be used, but often are not as effective as pure ascorbic acid.

Fruits may be steam-blanching. However, blanched fruits may turn soft and become difficult to handle.

Syrup blanching may help retain the color of apples, apricots, figs, nectarines, peaches, pears and plums. A sweetened candied product will result.

Fruits with tough skins (grapes, prunes and small dark plums, cherries, figs and some berries) may be water-blanching to crack the skins. This will allow moisture inside to surface more readily during drying.

Before drying pretreated food, remove any excess moisture by placing the food on paper towels or clean cloths. Drying trays should be loaded with a thin layer of food as directed. If needed, clean cheesecloth can be spread on the trays to prevent food pieces from sticking or falling through.

The amount of food being dried at one time should not exceed roughly 3/4 of each tray's surface area and a 1/4" thick.

RECONSTITUTING FOODS

All dehydrated foods need to be reconstituted. Most fruits are actually preferable in their dried form. Most vegetables, however, are most taste-tempting when reconstituted.

To reconstitute vegetables for cooking, merely wash product in clean water, then place in an amount of cold, unsalted water and cover. Soak 2 to 8 hours, if possible, then cook in same water used for soaking. Add more water if necessary. Bring product to a boil, then reduce heat to simmer just until done. Add salt, if desired, at end of cooking time, as salt slows down the reconstitution process. As with fresh products, overcooking will diminish flavor and texture. To reconstitute vegetables like carrots, soak in ice water or soak in water in the refrigerator.

Dried foods can be reconstituted by soaking, cooking, or a combination of both and will resemble their fresh counterparts after reconstitution. However, dried foods are unique and should not be expected to resemble a fresh product in every respect.

Drying does not render the food free of bacteria, yeasts, and molds. Thus, spoilage could occur if soaking is prolonged at room temperature. Refrigerate if soaking for longer than 1 to 2 hours.

To conserve nutritive value, use the liquid remaining after soaking and cooking as part of the water needed in recipes.

One cup of dried vegetables reconstitutes to about 2 cups. To replace the moisture removed from most vegetables, barely cover them with cold water and soak 20 minutes to 2 hours. Cover greens with boiling water. To cook, bring simmer until done.

One cup of dried fruit reconstitutes to about 1 1/2 cups. Add water just to cover the fruit; more can be added later if needed. One to eight hours are required to reconstitute most fruits, depending on fruit type, size of pieces, and water temperature. (Hot water takes less time). Over-soaking will produce a loss of flavor. To cook reconstituted fruit, cover and simmer in the soak water.

Dried or reconstituted fruits and vegetables can be used in a variety of ways.

Use dried fruit for snacks at home, on the trail, or on the ski slopes. Use pieces in cookies or confections.

Serve reconstituted fruit as compotes or as sauces. It can be incorporated into favorite recipes for breads, gelatin salads, omelets, pies, stuffing, milk-shakes, homemade ice cream and cooked cereals.

Add dried vegetables to soups and stews or vegetable dishes. Use as dry snacks or dip chips.

Include reconstituted vegetables in favorite recipes for meat pies and other main dishes, as well as gelatin and vegetable salads.

Powdered vegetables in the dried form make a tasty addition to broths, raw soups, and dressings.

For optimum maintenance of nutritional value, we suggest:

- Blanching the correct length of time.
- Packaging dried foods properly and storing containers in a cool, dry, dark place.
- Checking dried foods periodically during storage to insure that moisture has not been reabsorbed.
- Eating dried foods as soon as possible.
- Using liquid remaining after reconstitution in recipes.

DRYING

Drying time varies according to fruit or vegetable type, size of pieces, and tray load.

Before testing foods for desired dryness, remove a handful and cool for a few minutes. Foods that are warm or hot seem softer, moister, and more pliable than they will when cooled.

Foods should be dry enough to prevent microbial growth and subsequent spoilage. Dried vegetables should be hard and brittle. Dried fruits should be leathery and pliable. For long-term storage, home dried fruits will need to be drier than commercially dried fruits sold in grocery stores.

PACKING AND STORAGE

Fruits cut into a wide range of sizes should be allowed to „sweat “ or condition for a week after drying to equalize the moisture among the pieces before placing in long-term storage. Place fruit in a non-aluminum, non-plastic container and put in a dry, well-ventilated and protected area.

Dried foods should be thoroughly cooled before packing. Package in small amounts so that food can be used soon after containers have been opened.

Pack food as tightly as possible without crushing into clean, dry, insect-proof containers. Glass jars or moisture vapor proof freezer cartons or bags (heavy gauge plastic type) make good containers. Metal cans with lids can be used if the dried food is first placed in a plastic bag.

Your dehydrated food should be checked about once a month. Should you find mold growing on a piece of the dried food, scrape it off and then pasteurize the contents.

To pasteurize the contents, spread food on a cookie sheet and bake in oven for 15 minutes at 175 degrees Fahrenheit. Repack in a clean, airtight container.

ROTATING THE TRAYS

Your new Food Dehydrator is scientifically designed to rely on natural heat convection to carry away moist air from the food. Trays should be rotated during the processing period to insure even drying. Trays nearest the bottom exposed to the hottest, driest air will dry more rapidly. So simply move them up and move the ones on top to the bottom.

REMEMBER

- 1) The best results are achieved when the quality of the food is high. Be sure to select ripe produce in good condition, as one bad food may give an off-flavor to the entire lot.
- 2) Clean produce is important. Wash thoroughly, remove soft or spoiled areas, slice and pretreat if necessary. Be certain that your hands, your cutting utensils and your food preparing area are also clean.
- 3) You can expect a variation in the drying times. Drying times are affected with the size of the load, thickness of the sliced products, humidity of the air, and the moisture content of the food itself.
- 4) Be sure to let the produce cool before testing for dryness.
- 5) Trays may be fully loaded, if desired, with pieces barely touching but not overlapping.
- 6) About six to ten percent of the moisture may remain in your foods without danger of spoilage. Many dried foods will have a leathery consistency, rather like licorice.
- 7) Rotate trays if you notice uneven drying or a very heavy load. Just move bottom tray up to the middle and top ones down.
- 8) To remove seeds or pits from prunes, grapes, cherries etc., dehydrate 50 % then pop seeds out. This prevents juice from dripping out.

Mixed bag of fruit
2 bananas (peeled)
1/2 pound strawberries
1 cup pineapple chunks (canned)

Sliced fruit uniformly, about 1/4 inch thick. Add 1/4 cup of mixed nuts after drying and cooling.

Apple cinnamon rings
5 pounds of apples
5 teaspoons of cinnamon

Peel and core apples with a cylindrical apple corer. Slice into 1/4 inch rings. Sprinkle with cinnamon prior to drying.

Citrus threesome
3 pounds oranges
5 lemons
4 firm grapefruits

Wash fruit. Leaving rind on, slice all fruit uniformly, 1/4 inch thick. Place in dehydrator trays and dry.

Tropical paradise
10 kiwis
1 pineapple
3 papayas

Peel papayas and kiwis. Remove core and skin from pineapple. Slice all fruit uniformly, about 1/4 inch thick. Place in dehydrator trays and dry.

Strawberry treats
2 cups fresh strawberries – cleaned, put into blender along with a small amount of apple juice to help liquify the berries. Line tray(s) with plastic wrap. Pour blended berries onto wrap, evenly spreading with a spatula. Dehydrate for 6 hours – approximately (depending on if you prefer brittle or chewy). Top vents open.

Jerky

In a 9 x 13 baking dish marinate thinly sliced beef or turkey in 1/4 of cup soy sauce, 2x tablespoon of brown sugar and 2x tablespoon of liquid smoke (optional). Stir well, making sure to coat each piece of meat. Cover with plastic wrap and let stand for 10-15 minutes. When marinate is through, line each piece of meat on tray so they are barely touching. The thinner the cuts of meat are, the shorter the dehydration process is. 8-10 hours for 1/16 " slices (depending on how chewy you prefer). Top vents open.

Sachets and potpourris

You can save the fragrance of spring and summer and enjoy whatever sweet – smelling plants you have in your flower and herb garden with the Family Size food Dehydrator. Select petals from the flower and place them loosely on the mesh tray and place them in your dehydrator with all vents wide open. When perfectly dried (about five hours), store the petals in decorative containers or sachet bags and close with a ribbon.

You can sprinkle the petals with spices like powdered cinnamon, whole cloves, a bit of dried rosemary or mint for variety. It is best to keep the container closed until all of the fragrances have blended.

DRYING TABLE FOR FRUITS

The times are approximate. Your drying times will vary with room temperature, humidity, moisture content of the food and how thinly the food is sliced. The presence of natural juices in food will also vary. Some fruit sugars tend to be stickier than others.

FRUIT	PREPARATION	DRYNESS TEST	TIME
Apples	Pare, core and cut in slices or rings. Dip in pretreatment for 2 minutes. Drain and place on tray.	Pliable	4 – 15 hrs.
Apricots	Dry in halves and turn inside out or cut into quarters. Pretreat to help retain color without penetrating skin of fruit.	Pliable	8 – 36 hrs.
Bananas	Peel and cut into 1/8 " slices.	Crisp	5 – 24 hrs.
Berries	Strawberries may be sliced in 3/8 " slices. Leave other berries whole. Bathe wax-coated berries in boiling water.	No visible moisture	5 – 24 hrs.
Cherries	Do not stem until ready to prepare. Pitting is optional, or pit when 50 % dry.	Leathery but sticky	6 – 36 hrs.
Cranberries	Wash well, chop for flakes or leave whole.	No visible moisture	4 – 20 hrs.
Grapes (raisins)	Wash, remove stems and leave whole.	Pliable and leathery	6 – 36 hrs.
Nectarines	No need to peel. Dry with skin down on screen, or cut in 3/8 " slices or circles.	Pliable	6 – 24 hrs.
Orange Rind	Peel in long strips and dry. Do not grate until ready to use.	Brittle	6 – 15 hrs.
Peaches	Remove peels during dehydration if desired. Pit when 50 % dehydrated. Halve or quarter, with cup size up.	Pliable and leathery	5 – 24 hrs.
Pears	Peel, remove core and woody tissue. Cut into slices or rings, halves, quarters or eights.	Pliable and leathery	5 – 24 hrs.
Persimmons	Use only ripe fruit. Wash, remove cap, slice in 3/8 " circles or slices.	Pliable	5 – 20 hrs.
Pineapple (fresh)	Remove core, cut in slices or wedges or chunks.	Pliable	6 – 36 hrs.
Pineapple (canned)	Drain and pat dry. Place on trays.	Leathery	6 – 36 hrs.
Plums	Wash, leave whole or cut in half and remove pits or pop them out when half dried.	Pliable	5 – 24 hrs.
Prunes	Same as plums, but soak in boiling water for two minutes first.	Leathery	8 – 36 hrs.
Rhubarb	Use only tender stalks. Wash, cut in 1 " lengths.	No visible moisture	4 – 16 hrs.

DRYING TABLE FOR VEGETABLES

VEGETABLE	PREPARATION	DRYNESS TEST	TIME
Artichoke Hearts	Cut hearts into 1/8 " strips. Boil 5-8 minutes in 3/4 cup water containing 1 tablespoonful lemon juice.	Brittle	4 – 12 hrs.
Asparagus	Wash and cut into 1 " pieces. Tips yield better product. Stems, crushed after drying, make an excellent seasoning.	Brittle	4 – 10 hrs.
Beans (Green or Wax)	Cut into 1 " pieces or cut French style. Steam blanch until translucent. Stir beans on tray after partial drying, moving inside beans to outside for more even drying.	Brittle	4 – 14 hrs.
Beets	Trim off all but one inch of tops and roots. Wash, blanch, cool, remove tops, skin and roots. Dice or slice.	Brittle, dark	4 – 12 hrs.
Brussels Sprouts	Cut sprouts from stalks, cut in half lengthwise through stem.	Brittle	5 – 15 hrs.
Broccoli	Trim, cut as for serving, wash thoroughly. Steam tender, about 3-5 minutes.	Brittle	5 – 15 hrs.
Cabbage	Trim, cut into strips 1/8 " thick. Cut core into 1/4 " strips. Use bottom shelf of dehydrator.	Leathery	4 – 12 hrs.
Carrots	Select young tender roots. Steam until tender. Cut into slices, shreds, cubes or strips.	Leathery	4 – 12 hrs.
Cauliflower	Dip cauliflowers into 3 tablespoons salt per 2 quarts of water for 2 minutes. Steam until tender.	Leathery	5 – 15 hrs.
Celery	Separate stalks from leaves. Wash both thoroughly. Cut stalks into 1/4 " slices. Leaves dry first, so remove when dry. Flake leaves after drying for use in soups, stews, etc.	Brittle	4 – 12 hrs.
Corn	Remove husks, silk and blemishes just before steaming. Blanch on cob until milk is set. Cut from cob and spread over tray. Stir several times for even drying.	Brittle	4 – 15 hrs.
Cucumber	Pare, slice in 1/8 " slices and dry.	Leathery	4 – 14 hrs.
Eggplant (also Kohlrabi, Summer and Italian Squashes, Zucchini)	Trim, wash and slice 1/4 " to 1/2 " thick, and spread on tray.	Brittle	4 – 14 hrs.
Onions and Leeks	Remove peels and cut into 1/2 " slices, nuggets, or chop. Stir several times during drying.	Leathery	4 – 10 hrs.
Okra	Use young, tender pods. Wash, trim, and slice into 1/4 " discs.	Leathery	3 – 10 hrs.

Parsley	Tear into small pieces, dry then chop if desired.		2 – 10 hrs.
Parsnips	Same as carrots.		
Peas	Use only tender, sweet varieties. Shell and blanch gently, 3-5 minutes.	Brittle	4 – 10 hrs.
Peppers (Green and Pimentos)	Cut in 1/4 " strips or rings. Remove seeds, wash and dry. May also be chopped. Chopped, dried pimentos are Paprika.	Brittle to leathery	4 – 10 hrs.
Hot Peppers	Wash and dry whole. Wear rubber gloves to protect hands when preparing hot peppers.	Leathery	4 – 12 hrs.
Potatoes	Peeling optional. Slice into 3/16 " to 1/4 " or dice, grate, cut French Fry style. Steam as for beets.	Brittle	5 – 12 hrs.
Chives	Chop – spread on tray.	Brittle	4 – 10 hrs.
Pumpkin (also Hubbard Squash)	Cut into small pieces. Bake or steam until tender. Cut into strips 1 to 3 inches wide, peel and remove pulp. Slice strips 1/2 " thick. Scrape pulp, place in blender to puree. Dry with paper towels.	Leathery	5 – 15 hrs.
Rutabagas	Same as carrots, but slice thin.		
Tomatoes	Wash and remove stems. Dip in boiling water to loosen skin. Cut in halves or slices.	Leathery	6 – 24 hrs.
Turnips	Same as carrots, but slice thin.		
Zucchini	See eggplant.		
Garlic	Separate into cloves and remove outer skin. Slice and dry on trays. Grind or process for seasoning, if desired, after drying.	Very brittle	4 – 15 hrs.
Greens (Spinach, Kale, Chard, Mustard, Turnip, Beet Greens)	Wash thoroughly and trim tough stems. Steam until wilted but not soggy. Use bottom tray of dehydrator but use it carefully not to scorch.	Very brittle	4 – 10 hrs.
Mushrooms	Select mushrooms with cap curling under – these are young and tender. Brush off dirt or wipe with damp cloth. Slice, chop or dry whole, depending on size.	Leathery to brittle, depending on size and age	3 – 10 hrs.

CLEANING AND MAINTENANCE

Before cleaning switch off the appliance and remove the mains plug from the wall socket.
 Clean with a soft, dry or damp cloth, if required with a neutral detergent.
 Do not use any abrasive cleaning agents, scourers etc. to clean the appliance.
 Remove the mains plug from the wall socket if the appliance has not been used for a long time.
 Before putting the appliance in storage, clean thoroughly then cover with a plastic bag and store in a dry place. Keep the appliance away from children!

Wash the drying trays and top lid in hot water, clean with neutral detergent, rinse in potable water and let them dry. Switch the appliance on without drying any foodstuffs and let it operate for min. 4 hours. Switch the appliance off and let all parts of the food dehydrator cool down and air so that the possible after production smell will be completely removed.

This procedure is recommended before using the appliance for the first time.

TECHNICAL SPECIFICATIONS

Rated voltage	220 – 240 V
Rated frequency50/60 Hz
Rated power input	280W
Safety class (for electric shock protection)	II
Noise level60 dB(A)

The declared noise emission level of the appliance is 60 dB(A), which represents a level A of acoustic power with respect to a reference acoustic power of 1 pW.

Glossary of technical terms

Safety class for electric shock protection:

Class II - Electric shock protection is provided by double or heavy-duty insulation.

Due to continuous improvement of the appliance, the manufacturer reserves the right to make changes to the text, design and technical specifications without prior notice.

INSTRUCTIONS AND INFORMATION REGARDING THE DISPOSAL OF USED PACKAGING MATERIALS

Dispose of packaging material at a public waste disposal site.

DISPOSAL OF USED ELECTRICAL AND ELECTRONIC APPLIANCES



The meaning of the symbol on the product, its accessory or packaging indicates that this product shall not be treated as household waste. Please, dispose of this product at your applicable collection point for the recycling of electrical & electronic equipment waste.

Alternatively in some states of the European Union or other European states you may return your products to your local retailer when buying an equivalent new product.

The correct disposal of this product will help save valuable natural resources and help in preventing the potential negative impact on the environment and human health, which could be caused as a result of improper liquidation of waste. Please ask your local authorities or the nearest waste collection centre for further details. The improper disposal of this type of waste may fall subject to national regulations for fines.

For business entities in the European Union

If you wish to dispose of an electrical or electronic device, request the necessary information from your seller or supplier.

Disposal in other countries outside the European Union

If you wish to dispose of this product, request the necessary information about the correct disposal method from local government departments or from your seller.



This product meets all the basic EU regulation requirements that relate to it.

Importer

The address MH STAR UK LTD

Unit 27, Perivale Park,

Horsenden lane South

Perivale, UB6 7RH