

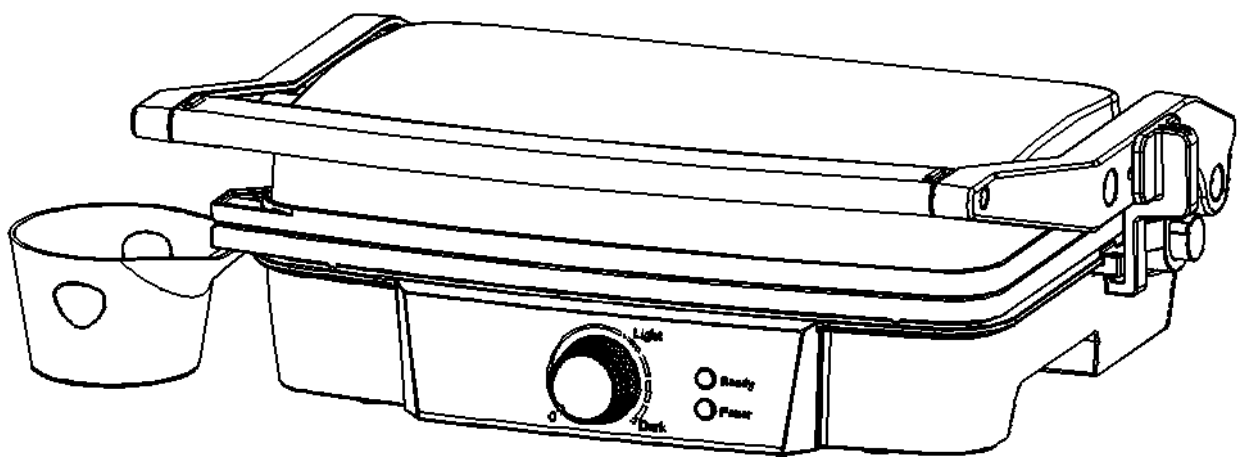

INcsb072V01\_US

**800-133**



## Contact Grill

- FOR INDOOR HOUSEHOLD USE ONLY -

IMPORTANT, RETAIN FOR FUTURE REFERENCE: READ CAREFULLY

# USING INSTRUCTION

## **IMPORTANT SAFEGUARDS**

### **● READ ALL INSTRUCTIONS**

- Use only on AC 120 Volt, 60 Hz. Use only for household.
- Do not touch hot surfaces. Use handle or knobs.
- To protect against risk of electric shock, do not immerse the cord, plug or cooking unit in water or any other liquid.
- Close supervision is necessary when any appliance is used by or near children.
- Unplug from outlet when not in use and before cleaning. Allow to cool before putting on or taking off parts, and before cleaning appliance.
- Do not operate any appliance with a damaged has malfunctioned or has been damaged in any manner. In order to avoid the risk of an electric shock, never try to repair the Grill Toaster yourself. Take it to an authorized service station for examination and repair. An incorrect reassembly could present a risk of electric shock when the Grill Toaster is used.
- The use of accessory attachments not recommended by the manufacturer may result in fire, electrical shock, or risk of injury to persons.
- Do not use outdoors or for commercial purposes.
- Do not let power cord hang over the edge of the table or counter, or touch hot surfaces.
- Do not place on or near a hot gas or electric burner or heated oven.
- Unplug the unit when finished using.
- Do not use appliance for other than intended use.
- Do not intend to operate by means of an external timer or separate remote-control system.
- Extreme caution must be exercised when moving an appliance containing hot oil or other hot liquids.

**WARNING: TO REDUCE THE RISK OF FIRE OR ELECTRIC SHOCK, ONLY AUTHORIZED PERSONNEL SHOULD DO REPAIRS.**

### **SAVE THESE INSTRUCTIONS**

### **FOR HOUSEHOLD USE ONLY**

### **GROUNDING PLUG**

To reduce the risk of electric shock this appliance has a grounded plug. If the plug does not fit fully into the electrical outlet contact a qualified electrician. Do not modify the plug in any way or use an adaptor.

## PARTS IDENTIFICATION

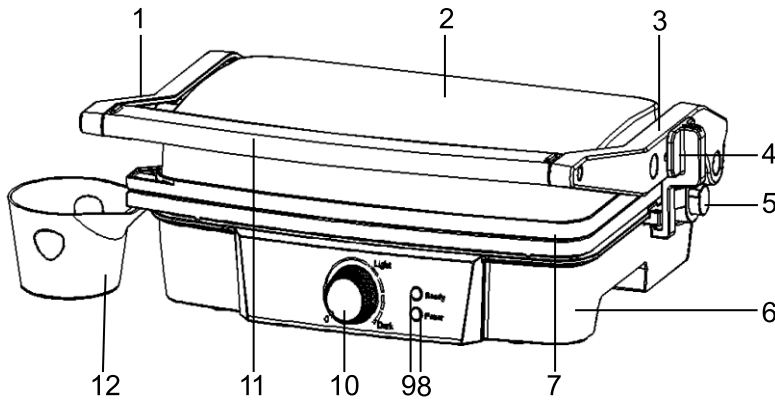

1. Left Lift lever
2. Upper Housing
3. Right Lift lever
4. Lift lever Button
5. 180° Angle button
6. Bottom Housing
7. Grill Non-stick Plate
8. Ready Light
9. Power Light
10. Thermostat Knob
11. Handle
12. Oil Tray

### Specification:

-----Voltage: 120V ~60Hz

-----Wattage: 1200 W

-----Adjustable temperature: 0 - 430°F ± 70°F

-----Timer :6-7 min

### BEFORE FIRST USE

- Read all instructions carefully and keep them for future reference.
- Remove all packaging
- Clean the Cooking Plates by wiping a sponge or cloth dampened in warm water.

**DO NOT IMMERSE THE UNIT AND DO NOT RUN WATER DIRECTLY ONT THE COOKING SURFACES.**

- Dry with a cloth or paper towel.
- For best results, lightly coat the cooking plates with a little cooking oil or cooking spray.

**Notice: When your Grill Toaster is heated for the first time, it may emit slight smoke or odor. This is normal with many heating appliances. This does not affect the safety of your appliance.**

### HOW TO USE

Before using the appliance for the first time, peel off any promotional materials and packaging materials, and check that the cooking plates are clean and free of dust. If necessary, wipe over with a damp cloth. For best results, pour a teaspoon of vegetable oil on to the non-stick plates. Spread over with an absorbent kitchen towel and wipe off any excess oil.

### PREPARING YOUR Grill TOASTER

- Close the Grill Toaster and plug it into the wall outlet, You will find the red power lights, indicating that the Grill Toaster has begun Power. As this time, you can be the right Thermostat Knob to set the temperature control to your desired setting: "MIN" for light colored food and "MAX" for darker food. At first, try a setting in the middle. Green ready light goes out You will find the green ready lights. Indicating that the Grill Toaster has begun preheating. You may later adjust it lower or higher according to your preference, Different foods will also cook up differently.

- It will be preheating approximately 3~5 minutes to reach baking temperature, you will find the green ready lights, the Grill Toaster is ready for use.

## COOKING

### To Use as a Contact Grill

- Set the Grill Toaster Temperature Control to your desired setting. At first, try a setting in the max.
- You may later adjust it lower or higher according to your preference.
- Prepare the burgers, boneless pieces of meat and thin cuts of meat or other foods as directed and place it onto the bottom cooking plate.
- Close the top cooking plate which has a floating hinge that is designed to evenly press down on the food. The top plate must be fully lowered to achieve Grill marks on the selected foods.
- When the foods is cooked use the handle to open the lid. Remove the food with the help of a plastic spatula. Never use metal tongs or a knife as these can cause damage to the non-stick coating of the cook plates.
- Use the Grill Toaster as a contact grill to cook burgers, boneless pieces of meat and thin cuts of meat and vegetables.

● Use the Grill-Toaster as a contact grill, when you want to cook something in a short amount of time or when you are looking for a healthy method of grilling. When cooked on the contact grill, food will cook quickly because you are grilling both sides of the food at the same time. The ribs on the grill plates combined with the grease spout at the corner of the plate allow the grease to drip from the meat and drain off the plates

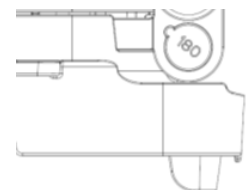
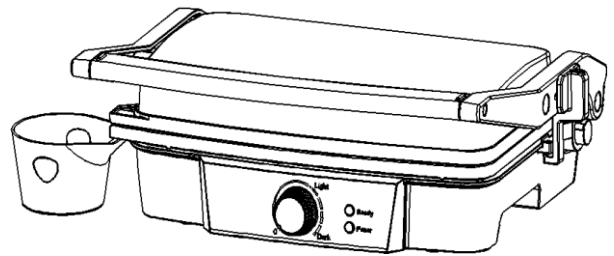

Slant Device

### Using the Extendable Feet

- In cooking, if you want the extra fat out better, you can open the extendable feet at the bottom.

### To Use as Press grill

- Set the Grill Toaster Temperature Control to your desired setting. At first, try a setting in the "MAX".
- You may later adjust it lower or higher according to your preference.
- Prepare the sandwiches as directed and place it onto the bottom cooking plate. Always place sandwiches towards the rear of the bottom cooking plate.
- Close the top cooking plate which has a floating hinge that is designed to evenly press down on the sandwich. The top plate must be fully lowered to cook sandwiches.
- Cook for about 3 to 6 minutes or until golden brown, adjusting the time to suit your own individual taste.
- When the sandwich is cooked use the handle to open the lid. Remove the sandwich with the help of a plastic spatula. Never use metal tongs or a knife as these can cause damage to the non-stick coating of the cook plates.
- Use the Grill Toaster as a Press grill to grill sandwiches, breads and quesadillas.
- The Grill Toaster was designed with a unique handle and hinge that allows the cover to adjust to the thickness of the food. You can easily grill anything from a thinly-sliced potato to a thick sirloin steak with even results.
- When cooking more than one food item in the contact grill, it is important that the thickness of food items is consistent so the cover will close evenly on the food.

### To Use as Open grill

- Place Grill Toaster on a clean flat surface where you intend to cook. The Grill Toaster can be positioned in flat position.

- Upper plate/cover is level with lower plate/base. The upper and lower plates line up to create one large cooking surface. The Grill Toaster to this position, locate the hinge release lever on the right arm.

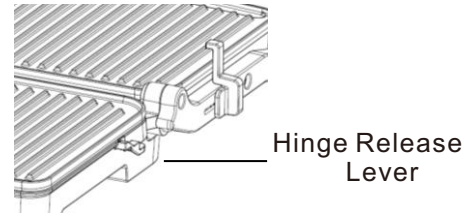

- Angle button—With you left hand on the handle, use your right hand to slide the lever toward you. Push the handle back until the cover rests flat on the counter. The unit will stay in this position until you lift the handle and cover to return it to the closed position.
- Use the Grill Toaster as an open grill to cook burgers, steak, poultry (we do not recommend cooking bone-in chicken, since it does not cook evenly on an open grill), fish and vegetables.
- Cooking on the open grill is the most versatile method of using the Grill Toaster. In the open position, you have double the surface area for grill.

- You have the option of cooking different types of foods on separates without combining their flavors, or cooking large amounts of the same type of food. The open position also accommodates different cuts of meat with varying thicknesses, allowing you to cook each piece to your liking.

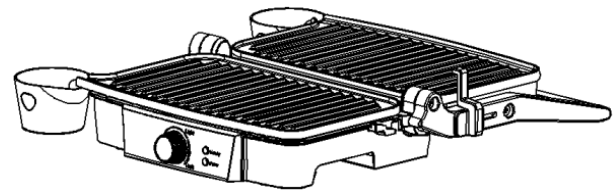

Flat Position

### CLEANING AND CARE

- Always unplug the Grill Toaster and allow it to cool before cleaning. The unit is easier to clean when slightly warm. There is no need to disassemble Grill Toaster for cleaning. Never immerse the Grill Toaster in water or place in dishwasher.
- The cooking plates can be cleaned in water.
- Wipe cooking plates with a soft to remove food residue. For baked on food residue squeeze some warm water mixed with detergent over the food residue then clean with a non-abrasive plastic scouring pad or place wet kitchen paper over the grill to moisten the food residue.
- Do not use anything abrasive that can scratch or damage the non-stick coating.
- Do not use metal utensils to remove your foods, they can damage the non-stick surface.
- Wipe the outside of the grill toaster with a damp cloth only. Do not clean the outside with any abrasive scouring pad or steel wool, as this will damage the finish. Do not immerse in water or any other liquid.
- Do not place in the dishwasher.
- Remove and empty the drip tray after each use and wash the tray in warm, soapy water. Avoid the use of scouring pads or harsh detergents as they may damage the surface.
- Rinse and dry thoroughly with a clean, soft cloth and replace.

### STORAGE

- Always unplug the Grill Toaster before storage.
- Always make sure the Grill Toaster is cool and dry before string.
- The power cord can be wrapped around the bottom of base for storing.