

kleanfin

INcva004V01_GL

834-296_834-297

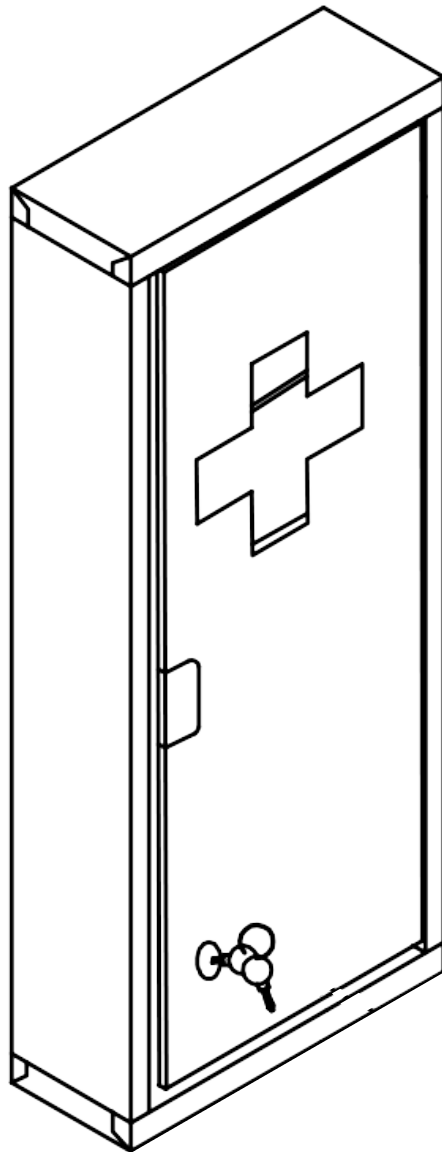

READ AND SAVE THIS INSTRUCTION FOR FUTURE USE

ASSEMBLY INSTRUCTION

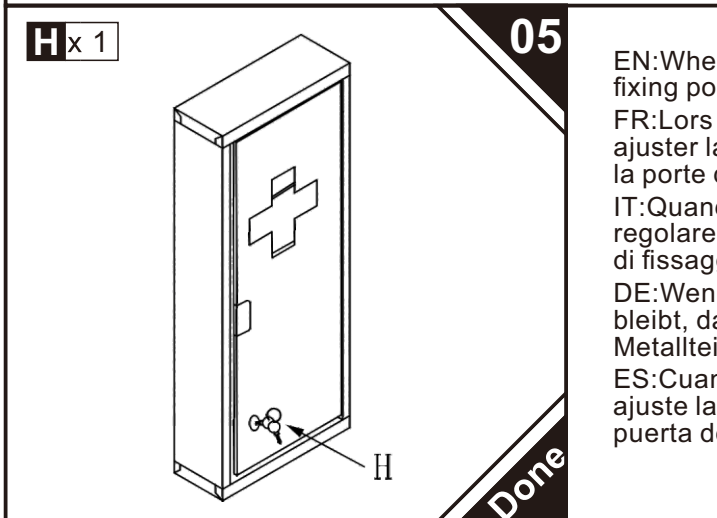
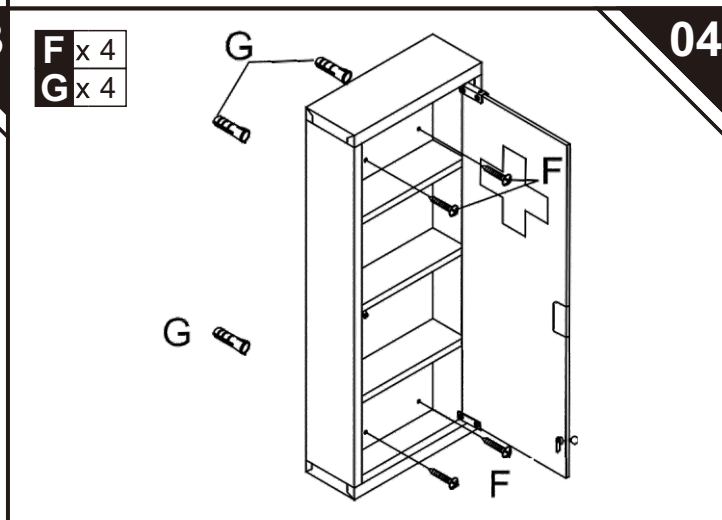
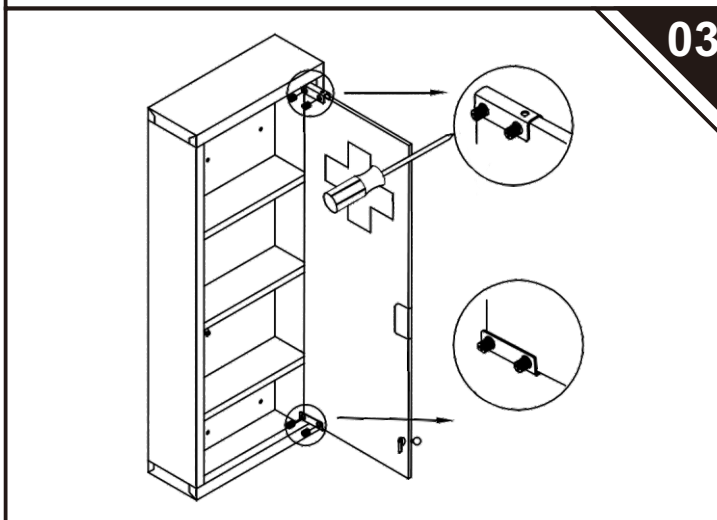
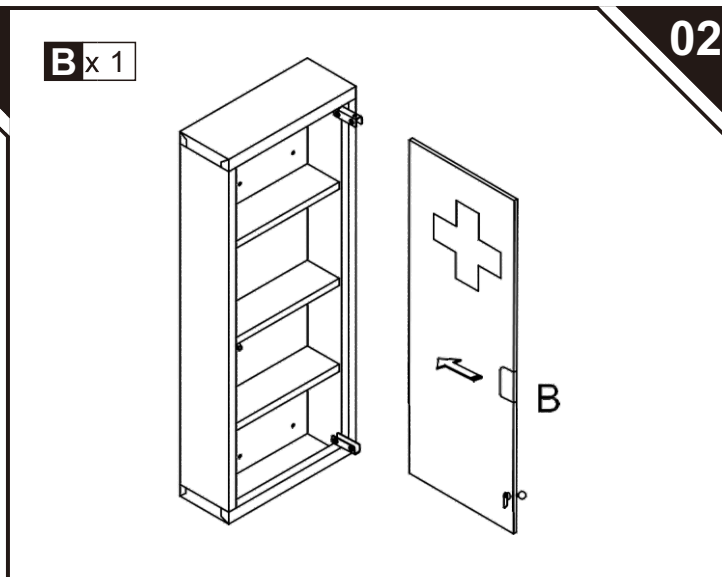
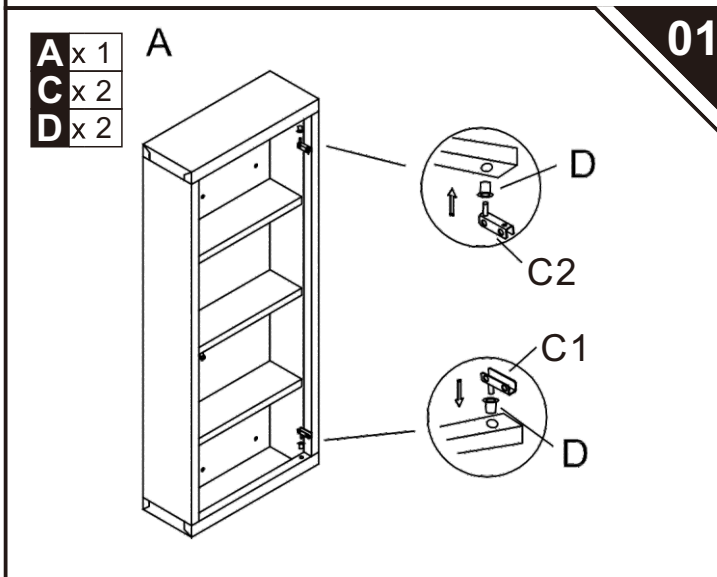
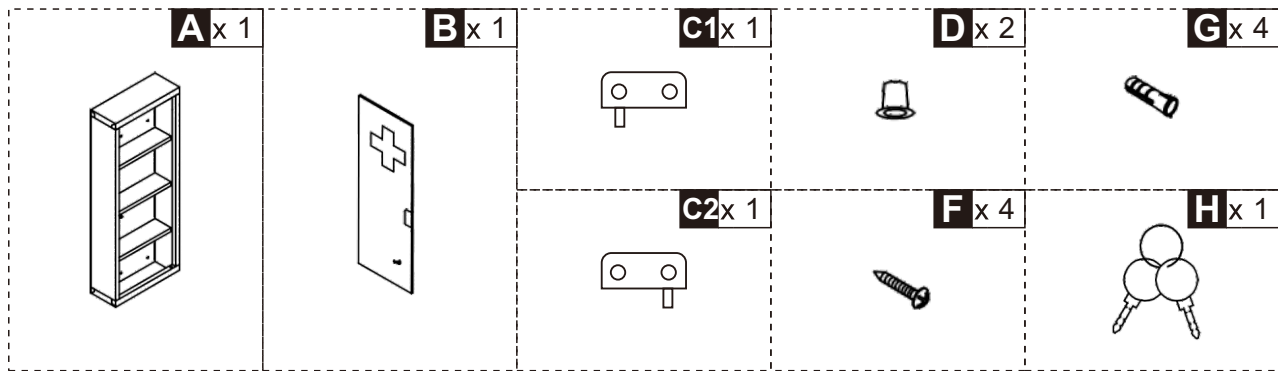

EN:When closing the door, if there is a gap, please adjust the fixing position of the metal parts C1, C2 and the door appropriately.
 FR:Lors de la fermeture de la porte, s'il y a un espace, veuillez ajuster la position de fixation des pièces métalliques C1, C2 et de la porte de manière appropriée.
 IT:Quando si chiude la porta, se vi e' una fessura, si prega di regolare in maniera appropriata la posizione delle parti metalliche di fissaggio C1, C2 e della porta.
 DE:Wenn beim Schließen der Tür ein Zwischenraum bestehen bleibt, dann richten Sie bitte die Befestigungspositionen der Metallteile C1 und C2 und die Tür passend aus.
 ES:Cuando cierre la puerta, si se aparece una brecha pequeña, ajuste la posición de la fijación de las partes metálicas C1, C2 y la puerta de manera adecuada.

Done

US



001-877-644-9366
customerservice@aosom.com

CA



001-855-537-6088
customerservice@aosom.ca

UK



0044-800-240-4004
enquiries@mhstar.co.uk

DE



0049-(0)40-88307530
service@aosom.de

FR



0033-1-84166106
contact@aosom.fr

ES



0034-931294512
atencioncliente@aosom.es

IT



0039-0249471447
clienti@aosom.it