

# kleanpin

INcvb069V02\_FR\_ES\_DE\_IT

834-397

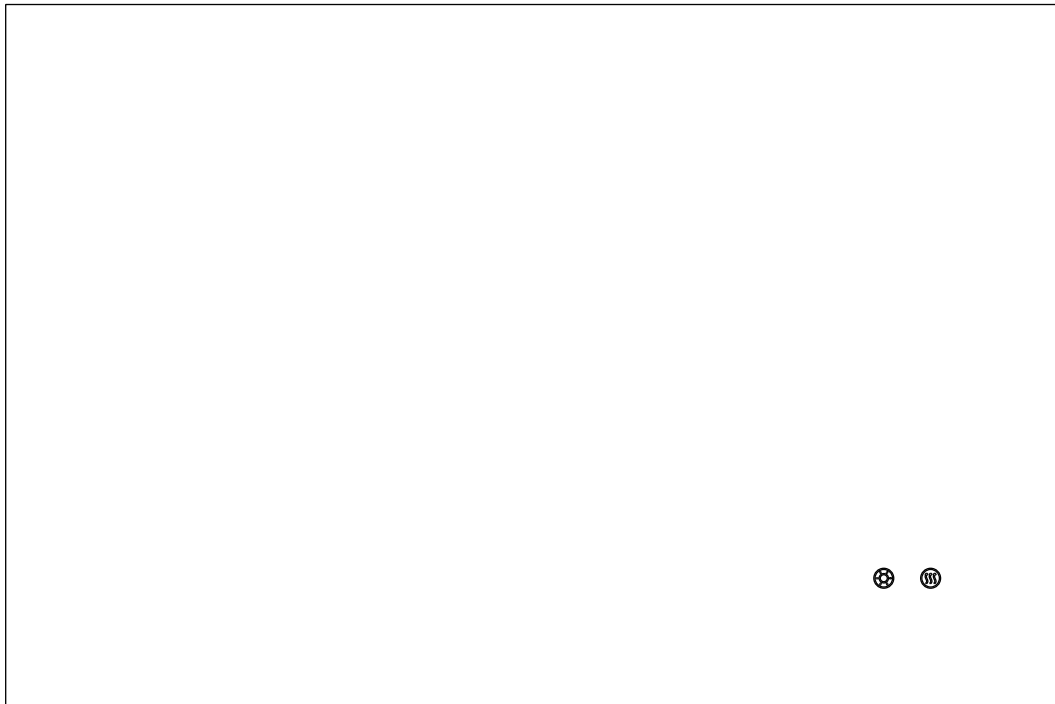

**EN\_IMPORTANT, RETAIN FOR FUTURE REFERENCE: READ CAREFULLY.**

**FR\_IMPORTANT: A LIRE ATTENTIVEMENT ET À CONSERVER POUR CONSULTATION  
ULTÉRIEURE.**

**ES\_IMPORTANTE, LEA Y GUARDE PARA FUTURAS REFERENCIAS.**

**DE\_„, WICHTIG! SORGFÄLTIG LESEN UND FÜR SPÄTER NACHSCHLAGEN AUFBEWAHREN.“**

**IT\_IMPORTANTE! CONSERVARE IL PRESENTE MANUALE PER FUTURO RIFERIMENTO E  
LEggerlo ATTENTAMENTE.**

## COMPOSANTS

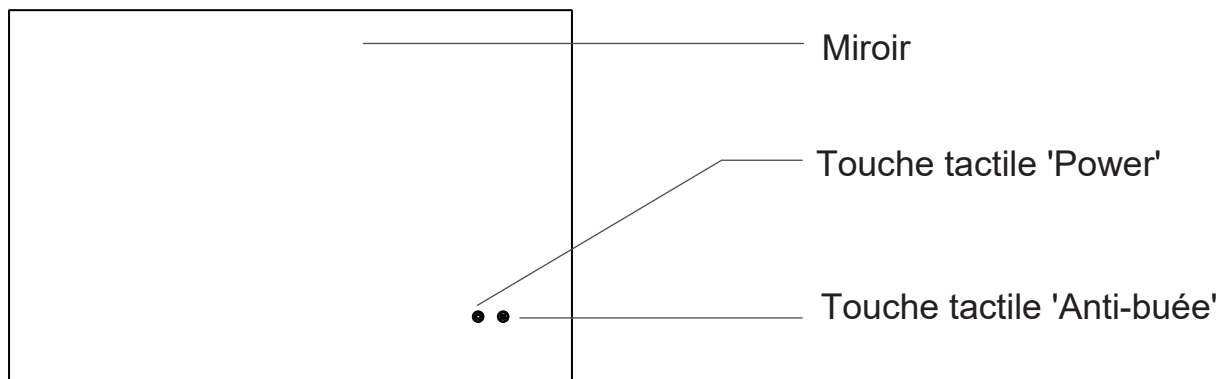

## CARACTÉRISTIQUES

Nom du produit : Miroir de salle de bain mural à LED

Matériau : Cadre en aluminium et verre

Température de couleur : 3000-6500K

Alimentation électrique : Pilote d'alimentation, 230V/50Hz

Dimensions du produit (cm) : 90H x 60L x 3,2E

Ce produit contient une source lumineuse de classe d'efficacité énergétique F.

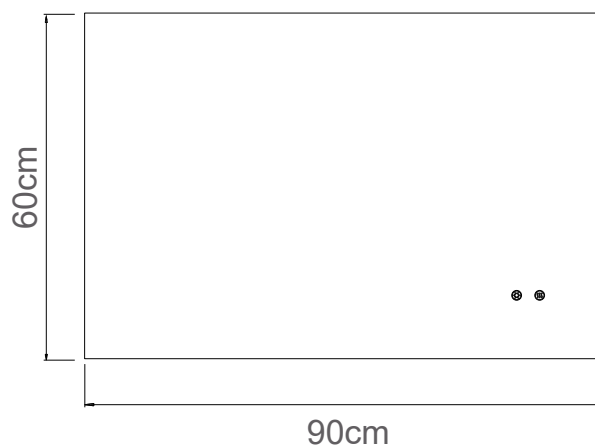

## FEATURES



Miroir en verre de 5 mm d'épaisseur



Choix entre des modes d'éclairage chaud, naturel ou froid



Touche tactile



Fonction anti-buée



Adaptateur

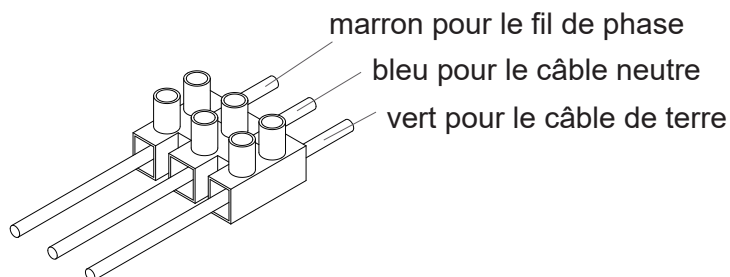

## CONTENU DE L'EMBALLAGE

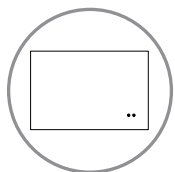

LED-Badezimmer-Spiegel



Gebrauchsanweisung

## MODE D'EMPLOI

- (1) Utilisez la fiche standard pour faire fonctionner l'appareil.
- (2) Le capteur tactile devient rouge lorsque l'appareil est branché. Appuyez sur 'Power' pour allumer l'appareil. Appuyez sur 'Anti-buée' pour activer fonctionnalité.
- (3) Les lumières sont à pleine luminosité à la mise en marche. Maintenez la touche 'Power' enfoncée pour régler la luminosité.
- (4) Appuyez sur 'Power' pour basculer entre les modes d'éclairage chaud, naturel et froid. Appuyez à nouveau sur cette touche pour éteindre l'appareil. Débranchez le miroir lorsqu'il est mis en arrêt.

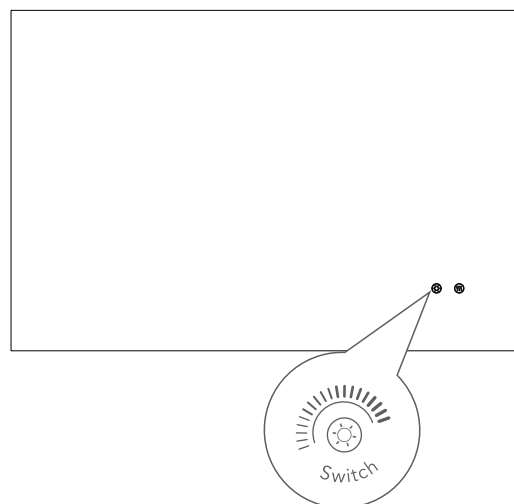

## MÉTHODE D'INSTALLATION

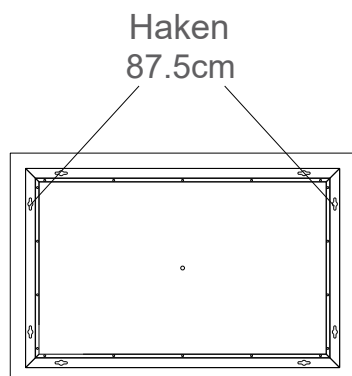

- ① Assurez-vous d'avoir un mètre ruban, une perceuse électrique, un marteau, un tournevis et des pinces.
- ② Déterminez la hauteur souhaitée sur un mur solide, et marquez deux points avec une distance horizontale de 87,5cm.
- ③ Percez des trous de 3 cm dans les points marqués. Placez la cheville en caoutchouc dans le trou et vissez-la.
- ④ Suspendez le produit au crochet situé à l'arrière.

## REEMPLACER LA BANDE LUMINEUSE



Préparez un tournevis, une pince ou un couteau.

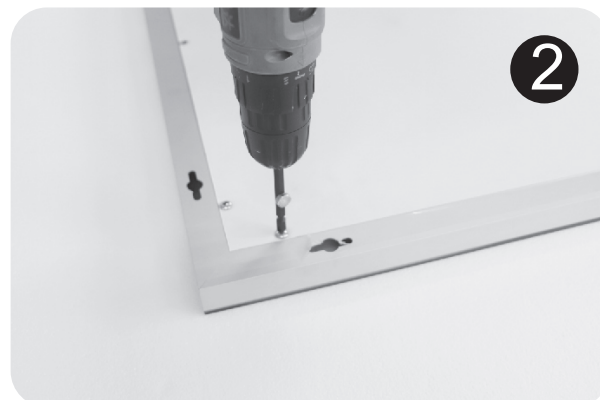

Retirez les vis à l'arrière.

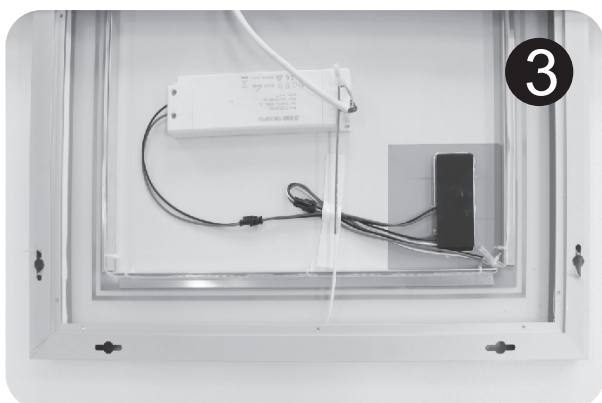

Vous pouvez voir les lignes tricolores collées sur le ruban adhésif.



Vous pouvez voir les lignes tricolores collées sur le ruban adhésif.



Retirer lentement la bande lumineuse de gauche à droite.



## CONSIGNES DE SÉCURITÉ

---

Veuillez lire attentivement ces consignes de sécurité avant d'utiliser le produit.

- ⓘ Ne pas démonter ou modifier le miroir
- ⓘ Ne pas appliquer une pression excessive sur le capteur tactile.
- ⓘ Gardez le miroir sec. L'humidité réduit la sensibilité de l'appareil.
- ⓘ Débranchez le miroir avant de le nettoyer, et n'utilisez qu'un nettoyeur pour vitres. Assurez-vous que le miroir est complètement sec avant de l'utiliser.
- ⓘ Éteignez l'appareil et protégez-le de la lumière directe du soleil lorsque vous le rangez. Tenez-le hors de portée des enfants.
- ⓘ N'utilisez pas le miroir s'il est défectueux.

\* Nous nous réservons le droit de modifier le produit en ce qui concerne la conception et les spécifications. Toutes les informations contenues dans ce document sont uniquement destinées à vous servir de référence et sont soumises aux produits que vous avez reçus. Aucun autre avis ne sera donné pour tout paramètre technique modifié

## COMPONENTES

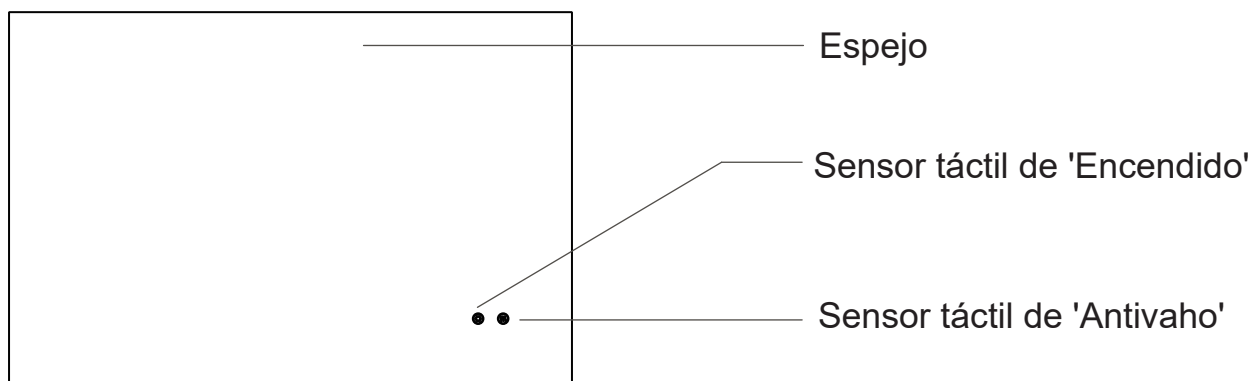

## ESPECIFICACIONES

Nombre del producto: Espejo de baño de pared con luz LED

Material: Marco de aluminio y vidrio.

Temperatura de color: 3000-6500K

Fuente de alimentación: Conductor de potencia, 230V/50Hz

Tamaño del producto: 70 Altura x 50 Longitud x 3,2 Ancho cm

Este producto contiene una fuente de luz de clase de eficiencia energética F.

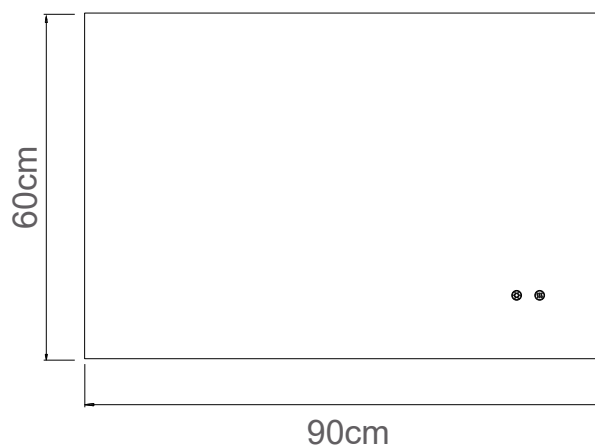

## CARACTERÍSTICAS



El grosor del espejo de vidrio es de 5 mm.



Seleccionar un estilo de iluminación entre "cálido", "natural" o "frío".



Sensor táctil



Función de 'Antivaho'



Adaptador

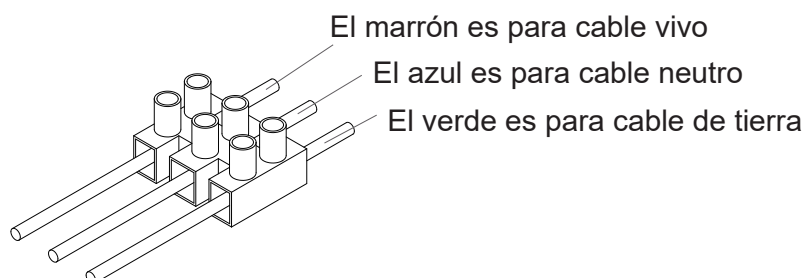

## LISTA DE ARTÍCULOS

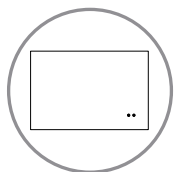

Espejo de baño con luz LED



Manual de instrucciones

## INSTRUCCIONES DE OPERACIÓN

- (1) Utilice el enchufe estándar para encender el espejo.
- (2) El sensor táctil se vuelve rojo cuando el espejo está enchufado. Presione la tecla de "Encendido" para encenderlo. Presione la tecla de 'Antivaho' para activar la función correspondiente.
- (3) Todo el brillo de las luces está encendido después de encender el espejo. Mantenga presionada la tecla de "Encendido" para ajustar el brillo.
- (4) Presione la tecla de 'Encendido' para cambiar la iluminación entre los 3 estilos de "cálido", "natural" y "frío". Presione la tecla de 'Encendido' nuevamente para apagar el espejo.
- (5) Desenchufe el espejo cuando esté apagado.

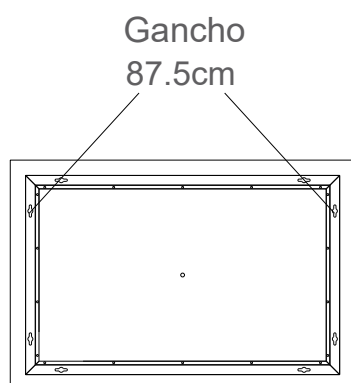
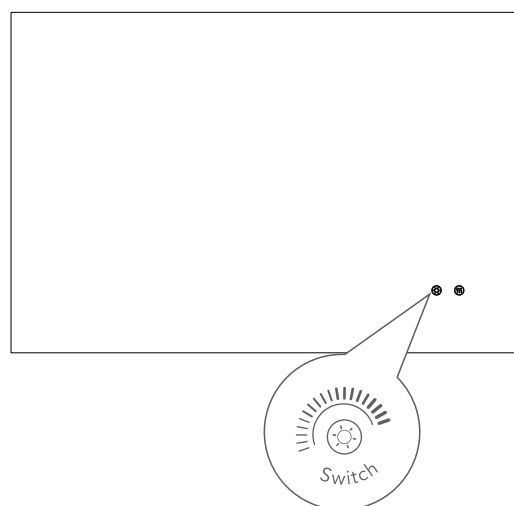

## MÉTODO DE INSTALACIÓN

- (1) Asegúrese de tener la cinta métrica, el taladro eléctrico, el martillo, el destornillador y los alicates.
- (2) Seleccione la altura ideal para instalar el espejo en la pared sólida y marque 2 puntos de modo que la distancia horizontal entre ellos son de 87,5 cm.
- (3) Taladre los agujeros con profundidad de 3 cm en los puntos marcados. Coloque el tapón de goma en cada agujero correspondientemente y atornille los tapones.
- (4) Cuelgue el espejo con el gancho ubicado en la parte trasera.

## REEMPLAZAR LA FAJA DE LUZ



Prepare un destornillador, unos alicates o un cuchillo.

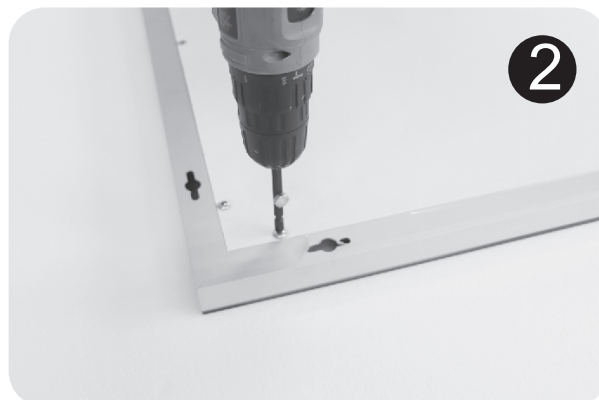

Quite el tornillo de la parte trasera.

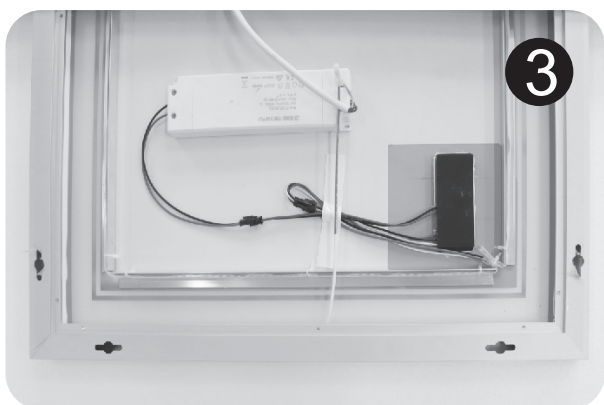

Puede ver las líneas de 3 colores que están pegadas a la cinta.



Puede ver las líneas de 3 colores que están pegadas a la cinta.

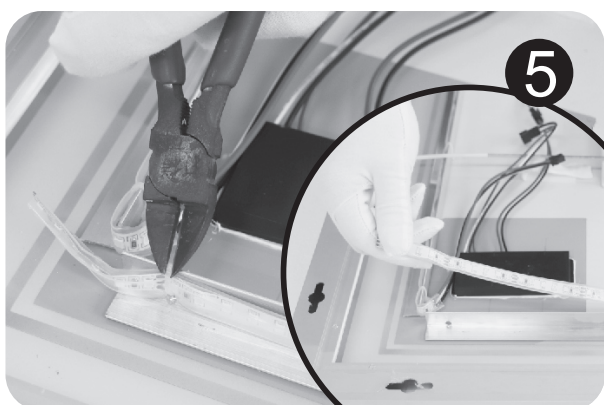

Quite la faja de luz de izquierda a derecha poco a poco.





## **INSTRUCCIONES DE SEGURIDAD**

---

Lea cuidadosamente todas estas instrucciones de seguridad antes de utilizar el espejo.

- ⓘ No desmonte ni modifique el espejo.
- ⓘ Presione suavemente el sensor táctil.
- ⓘ Mantenga el espejo seco. La humedad reducirá la sensibilidad del espejo.
- ⓘ Desenchufe el espejo antes de realizar la limpieza, y siempre utilice el limpiacristales.  
Asegúrese de que el espejo esté seco completamente antes del uso.
- ⓘ Apague el espejo y manténgalo alejado de la luz solar directa al almacenarlo.  
Manténgalo alejado de los niños.
- ⓘ No utilice el espejo si no funciona correctamente.

\* Nos reservamos el derecho de realizar cualquier modificación en el diseño y las especificaciones del producto, todos los materiales descritos aquí son solo para su referencia, y consulte el producto que recibió. Los parámetros técnicos están sujetos a cambios sin previo aviso.

## BESTANDTEILE

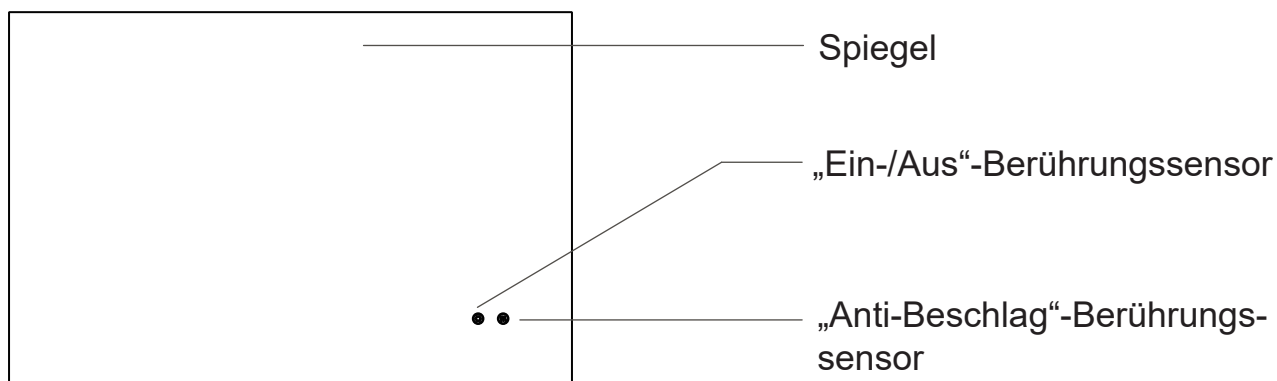

## SPEZIFIKATIONEN

Produktname: Wandmontierter LED-Badezimmerspiegel

Material: Aluminiumrahmen und Glas

Farbtemperatur: 3.000 K-6.500 K

Stromversorgung: Stromtreiber, 230V/50Hz

Produktgröße: 90 H x 60 L x 3,2 B cm.

Dieses Produkt enthält eine Lichtquelle der Energieeffizienzklasse F.

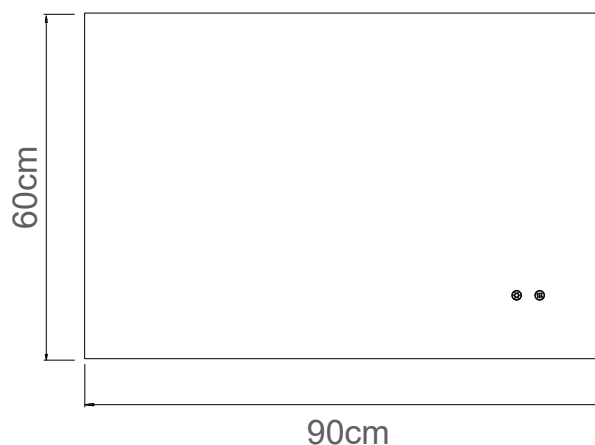

## MERKMALE



Glasspiegel ist 5mm dick



Wählen Sie zwischen warmer, natürlicher oder kühler Beleuchtung



Berührungssensor



Anti-Beschlag-Funktion



Adapter

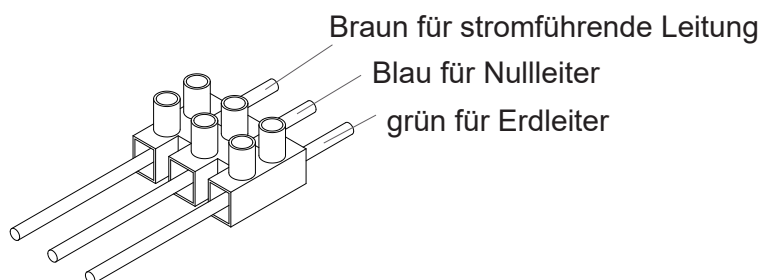

## TEILE LISTE

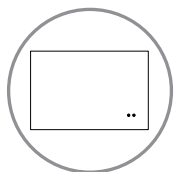

LED-Badezimmer-Spiegel



Gebrauchsanweisung

## BETRIEBSANLEITUNG

(1) Verwenden Sie den Standardstecker, um das Gerät einzuschalten.

(2) Der Berührungssensor leuchtet rot, wenn er eingesteckt ist. Drücken Sie zum Einschalten auf „Ein-/Aus“. Drücken Sie „Anti-Beschlag“, um diese Funktion zu aktivieren.

(3) Die Lichter sind auf voller Helligkeit, wenn sie eingeschaltet sind. Halten Sie die Taste „Ein-/Aus“ gedrückt, um die Helligkeit einzustellen.

(4) Drücken Sie auf „Ein-/Aus“, um zwischen warmer, natürlicher und kühler Beleuchtung zu wechseln. Drücken Sie erneut auf „Ein-/Aus“, um das Gerät auszuschalten.

(5) Ziehen Sie den Netzstecker, wenn das Gerät ausgeschaltet ist.

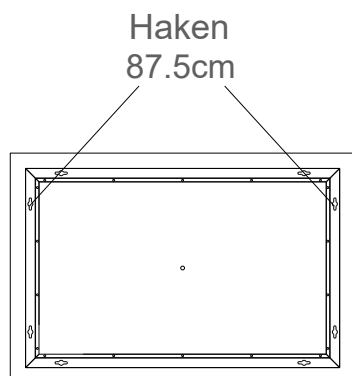
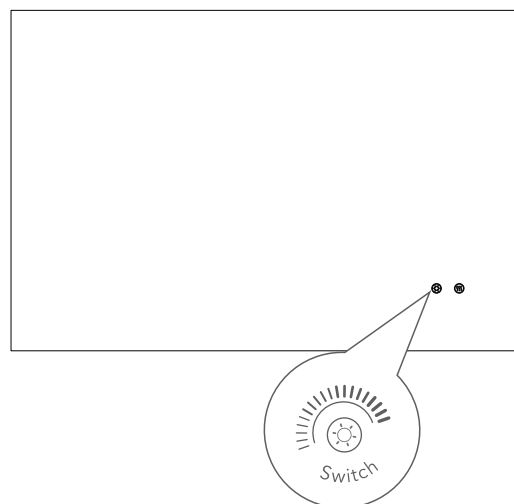

## INSTALLATIONSMETHODE

- ① Stellen Sie sicher, dass Sie ein Maßband, eine elektrische Bohrmaschine, einen Hammer, einen Schraubendreher und eine Zange haben.
- ② Wählen Sie die gewünschte Höhe an einer festen Wand und markieren Sie zwei Punkte mit einem horizontalen Abstand von 87.5 cm.
- ③ Bohren Sie 3 cm große Löcher in die markierten Punkte. Setzen Sie den Gummistopfen in das Loch und schrauben Sie ihn fest.
- ④ Hängen Sie das Produkt mit dem Haken auf der Rückseite auf.

## ERSETZEN DER LICHTLEISTE



Schraubenzieher, Zange oder Messer vorbereiten

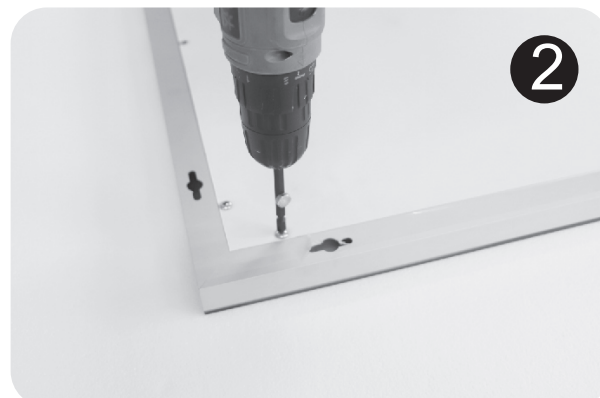

Die Schraube auf der Rückseite abnehmen



Sie können die dreifarbigen Linien sehen, die auf dem Band kleben



Sie können die dreifarbigen Linien sehen, die auf dem Band kleben

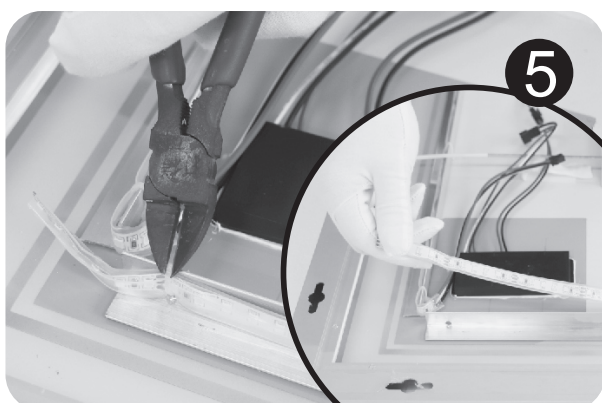

Nehmen Sie die Lichtleiste langsam von links nach rechts ab



## SICHERHEITSHINWEISE

---

Bitte lesen Sie diese Sicherheitshinweise sorgfältig durch, bevor Sie dieses Produkt verwenden.

- ⓘ Zerlegen oder verändern Sie nicht die Bestandteile des Spiegels.
- ⓘ Drücken Sie vorsichtig auf den Berührungssensor.
- ⓘ Halten Sie den Spiegel trocken. Feuchtigkeit verringert die Empfindlichkeit des Geräts.
- ⓘ Ziehen Sie vor der Reinigung des Spiegels den Netzstecker und verwenden Sie einen Glasreiniger.  
Vergewissern Sie sich, dass der Spiegel vor der Benutzung vollständig trocken ist.
- ⓘ Schalten Sie das Gerät aus und schützen Sie es vor direkter Sonneneinstrahlung, wenn Sie es abstellen. Bewahren Sie ihn außerhalb der Reichweite von Kindern auf.
- ⓘ Benutzen Sie den Spiegel nicht, wenn er defekt ist.

\* Wir behalten uns das Recht vor, Änderungen am Produkt vorzunehmen, die das Design und die Spezifikation betreffen. Alle hier aufgeführten Materialien dienen nur als Referenz und unterliegen den Produkten, die Sie erhalten haben. Es werden keine weiteren Hinweise auf geänderte technische Parameter gegeben.

## COMPONENTI

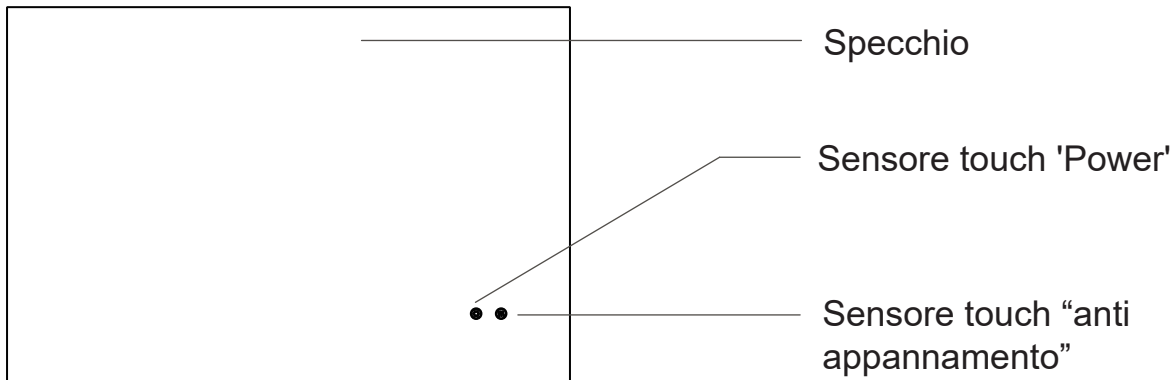

## SPECIFICHE

Nome prodotto: Specchio da bagno LED  
montato a parete

Materiale: Cornice in alluminio e vetro

Temperatura di colore: 3000-6500k

Alimentazione: alimentatore da 230V/50Hz

Dimensione prodotto: 90H x 60L x 3,2Wcm

Questo prodotto contiene una spia luminosa di classe di efficienza energetica F.

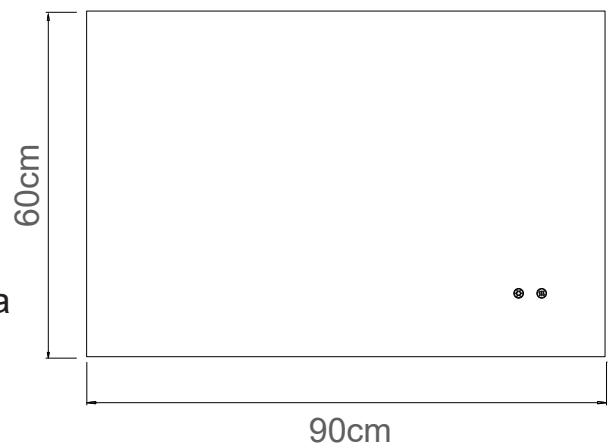

## CARATTERISTICHE



Specchio di vetro spesso 5 mm



Selezione tra luce calda, naturale o fredda



Sensore touch



Funzione anti-appannamento



Adattatore

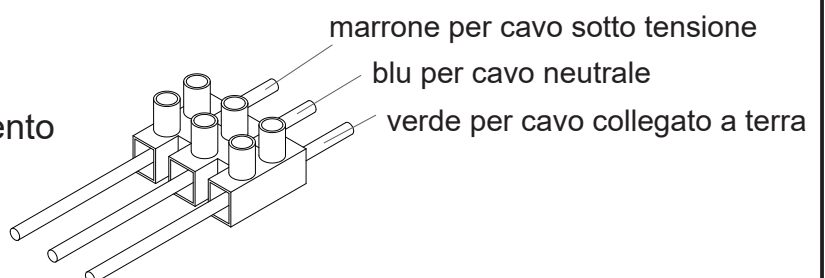

## LISTA DI ARTICOLI OF ITEMS

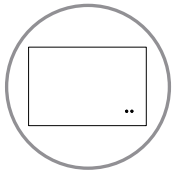

Specchio da bagno LED



Manuale d'uso

## ISTRUZIONI DI FUNZIONAMENTO

- (1) Utilizzare la spina standard per accendere l'apparecchio.
- (2) Il sensore touch diventa rosso quando è collegato alla corrente. Premere 'power' per accendere. Premere "anti-appannamento" per attivare la funzione.
- (3) Luminosità massima quando le luci sono accese. Tenere premuto "Power" per regolare la luminosità.
- (4) Premere 'power' per alternare tra l'illuminazione calda, naturale e fredda. Premere di nuovo "power" per spegnere l'apparecchio.
- (5) Scollegare quando l'apparecchio è spento.

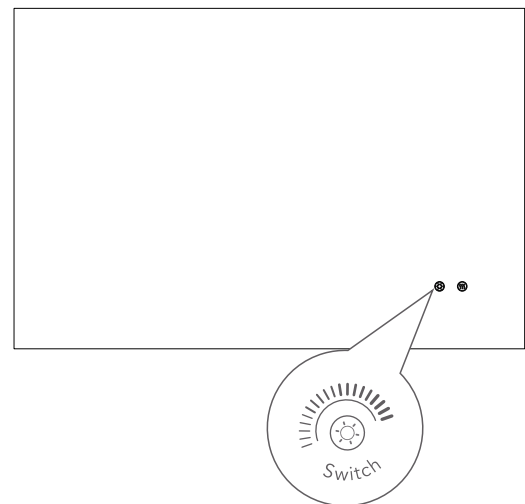

## METODO D'INSTALLAZIONE

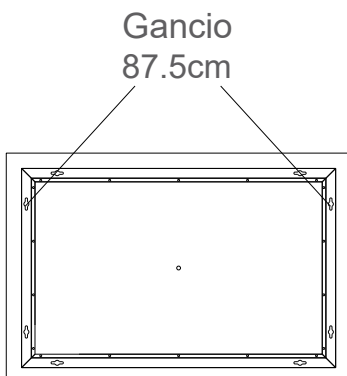

- ① Assicurarsi di avere un metro a nastro, un trapano elettrico, un martello, un cacciavite e una pinza.
- ② Selezionare l'altezza desiderata su una parete solida e contrassegnare due punti con una distanza orizzontale di 87,5 cm.
- ③ Praticare fori di 3 cm nei punti contrassegnati. Inserire il tappo di gomma nel foro e avvitare.
- ④ Appendere il prodotto con il gancio sul retro.

## SOSTITUZIONE DELLE STRISCE LUMINOSE



Preparare cacciavite, pinze o coltello

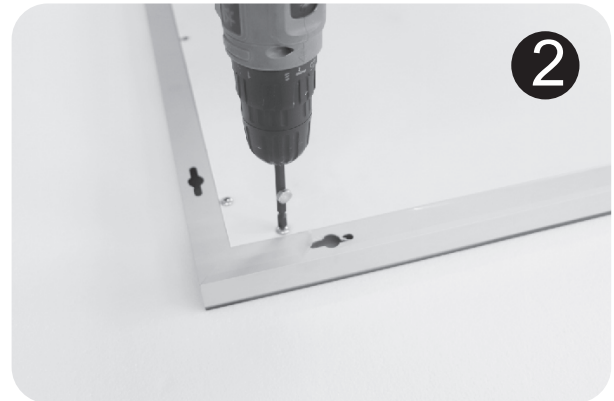

Rimuovere le viti sul retro

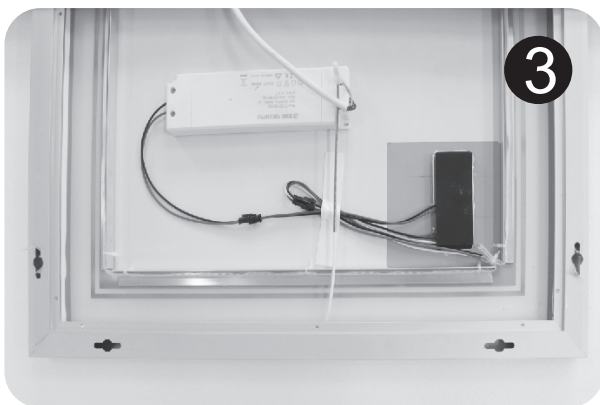

Potrete vedere i tre fili colorati attaccati al nastro



Potrete vedere i tre fili colorati attaccati al nastro

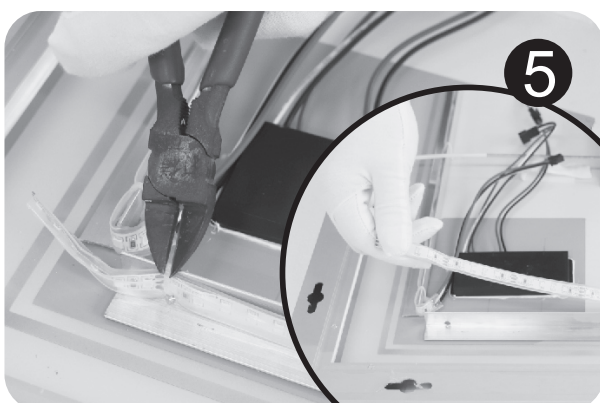

Rimuovere lentamente la striscia luminosa tirando da sinistra a destra





## **ISTRUZIONI DI SICUREZZA**

---

Si prega di leggere attentamente queste istruzioni di sicurezza prima di utilizzare il prodotto.

- ⓘ Non smontare o alterare lo specchio.
- ⓘ Premere il sensore touch delicatamente.
- ⓘ Mantenere lo specchio asciutto. L'umidità riduce la sensibilità dell'apparecchio.
- ⓘ Scollegare lo specchio prima di pulirlo e utilizzare un detergente per vetri. Assicurati che lo specchio sia completamente asciutto prima dell'uso.
- ⓘ Spegnerlo l'apparecchio e tenerlo lontano dalla luce solare diretta quando viene riposto.  
Tenere fuori dalla portata dei bambini.
- ⓘ Non usare se lo specchio è guasto.

\* Ci riserviamo il diritto di qualsiasi modifica del prodotto che coinvolga il design e le specifiche tecniche, tutte le indicazioni qui riportate sono solo per riferimento e sono soggette al prodotto ricevuto. Nessun ulteriore avviso sarà dato per eventuali parametri tecnici modificati.

## COMPONENTS

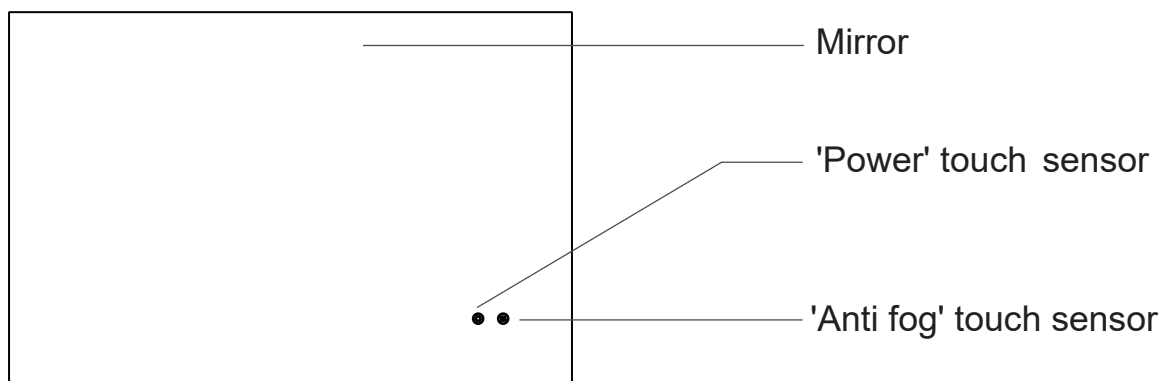

## SPECIFICATIONS

Product name: Wall-mounted LED bathroom

mirror Material: Aluminium frame and glass

Colour temperature: 3000-6500K

Power supply: Power driver, 230V/50Hz

Product size: 90H x 60L x 3.2Wcm

This product contains a light source of energy efficiency class F.

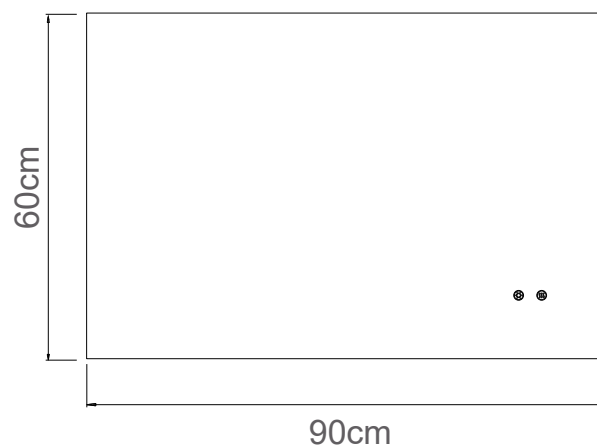

## FEATURES



Glass mirror is 5mm thick



Choose warm, natural or cool lighting



Touch sensor



Anti fog function



Adapter

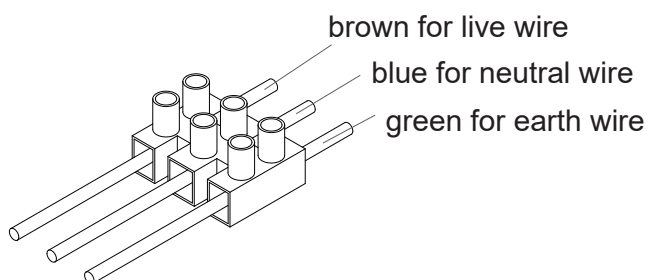

## LIST OF ITEMS

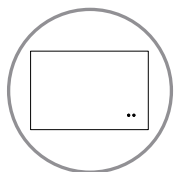

LED Bathroom Mirror



Instruction Manual

## OPERATING INSTRUCTIONS

- (1) Use the standard plug to turn on the appliance.
- (2) The touch sensor turns red when plugged in. Press 'power' to turn on. Press 'anti fog' to activate this function.
- (3) The lights are at full brightness when on. Hold 'power' to adjust the brightness.
- (4) Press 'power' to switch between warm, natural, and cool lighting. Press 'power' again to turn the appliance off.
- (5) Unplug when the appliance is off.

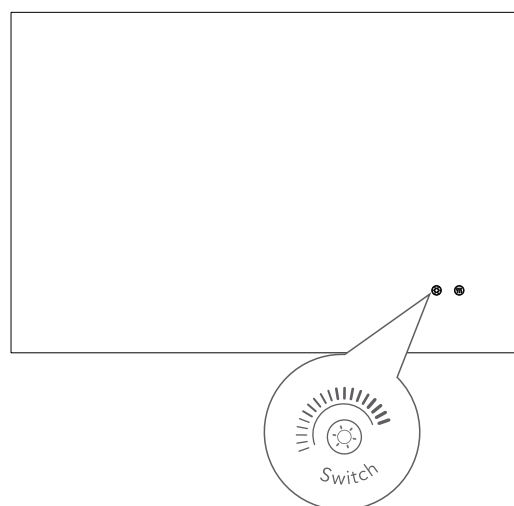

## INSTALLATION METHOD

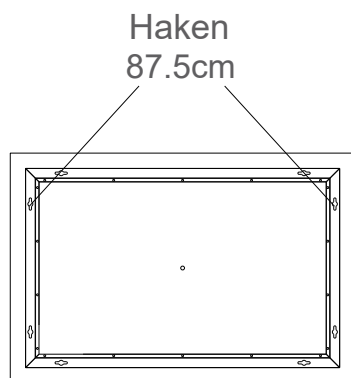

- ① Ensure you have a tape measure, electric drill, hammer, screwdriver and pliers.
- ② Select your desired height on a solid wall, and mark two dots with a 87.5cm horizontal distance.
- ③ Drill 3cm holes into the marked dots. Place the rubber plug into the hole and screw in.
- ④ Hang the product with the hook on the back.

## REPLACE THE LIGHT STRIP



Prepare screwdriver, pliers or knife

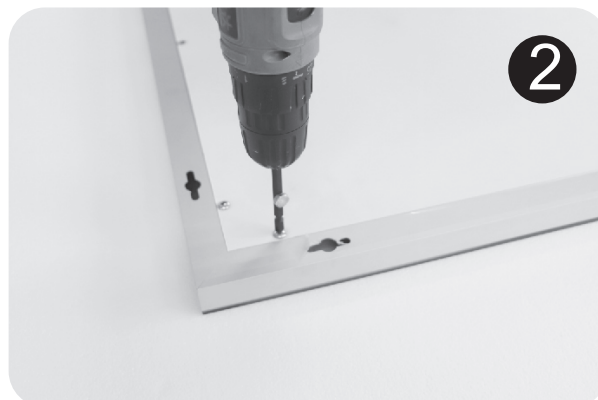

Take off the screw on the back

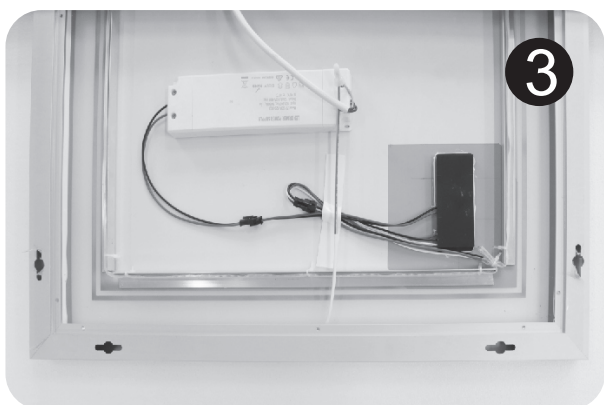

You can see the three-color lines stuck to the tape



You can see the three-color lines stuck to the tape

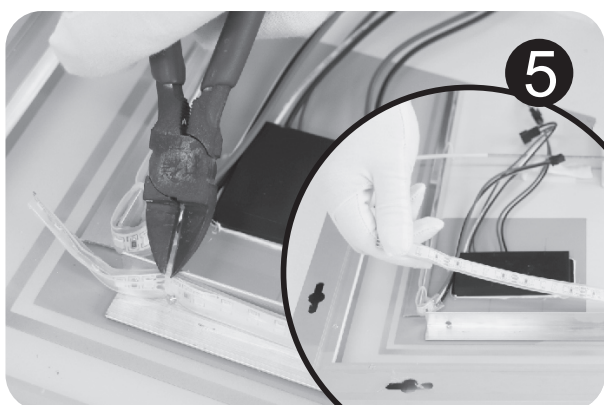

Take off the light strip from left to the right slowly



## **SAFETY INSTRUCTIONS**

---

Please read these safety instructions carefully before using this product.

- ⓘ Do not disassemble or alter the components of the mirror.
- ⓘ Press the touch sensor gently.
- ⓘ Keep the mirror dry. Moisture reduces the sensitivity of the appliance.
- ⓘ Unplug the mirror before cleaning, and use a glass cleaner. Make sure the mirror is completely dry before using.
- ⓘ Turn off and keep out of direct sunlight when stored away. Keep out the reach of children.
- ⓘ Do not use the mirror if it is faulty.

\* We reserves the right of any modification of the product involving design and specification, all the materials here are for your reference only and are subject to the products you received. No further notice be given for any technical parameters changed.



FR

**Pensez à  
donner ou recycler.**



Association

ou



Magasin

ou



Déchèterie

<https://quefairedemesdechets.fr>