

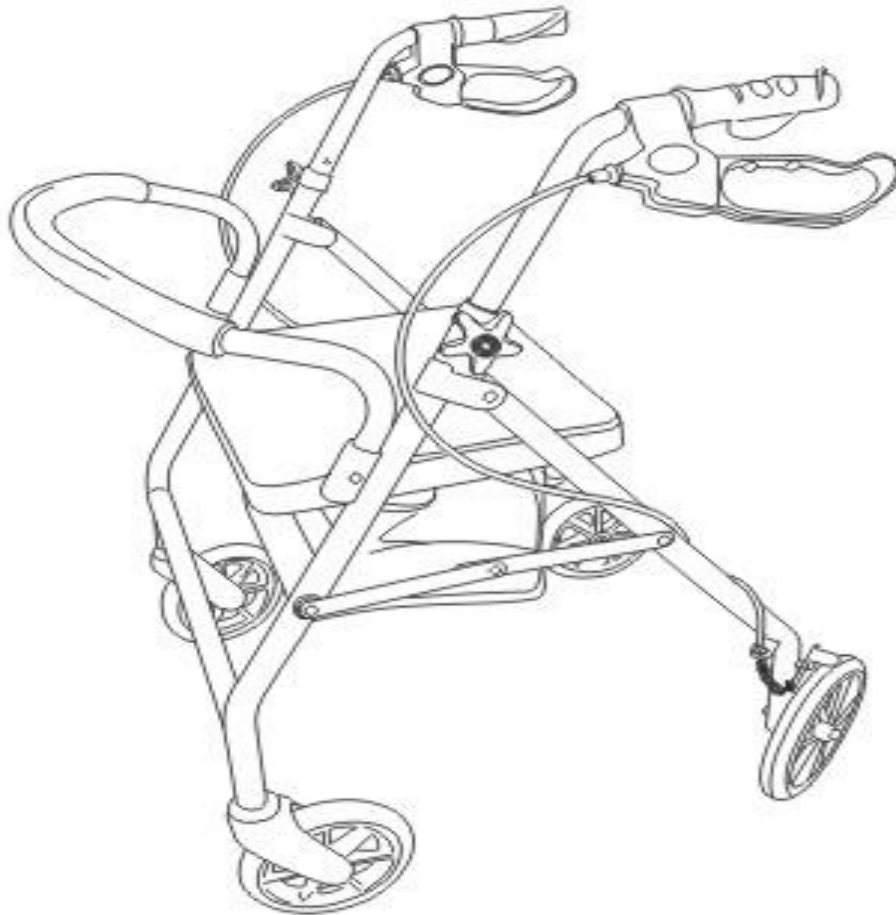

INcwb047V01_US_CA











712-040

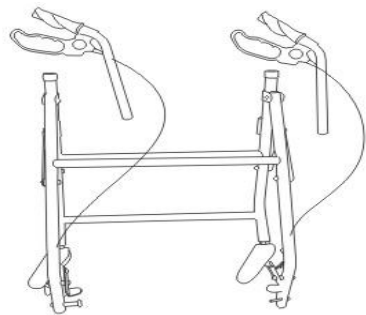

EN: IMPORTANT, RETAIN FOR FUTURE REFERENCE: READ CAREFULLY.

FR: IMPORTANT : A LIRE ATTENTIVEMENT ET À CONSERVER POUR CONSULTATION ULTÉRIEURE.

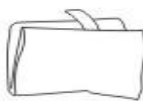
ASSEMBLY INSTRUCTION

 A x 4	 E x 1	 I x 1
 B x 2	 F x 1	
 C x 2	 G x 2	
 D x 1	 H x 1	 J x 4

TOOLS RECOMMENDED

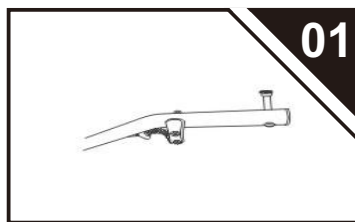

01

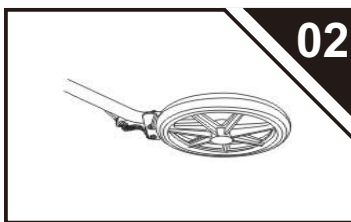

02

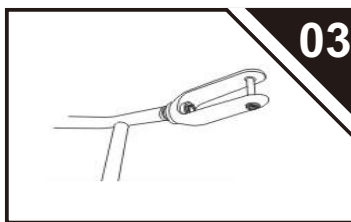

03

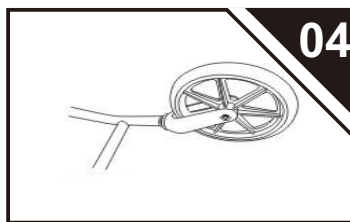

04

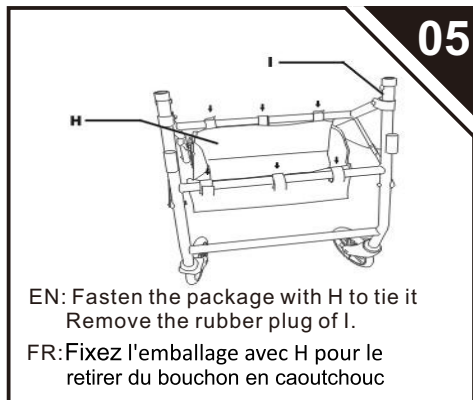

05

EN: Fasten the package with H to tie it
Remove the rubber plug of I.
FR: Fixez l'emballage avec H pour le retirer du bouchon en caoutchouc

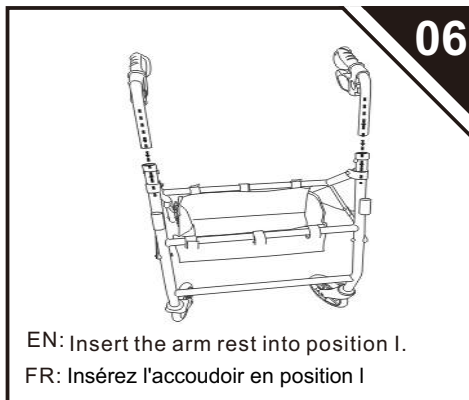

06

EN: Insert the arm rest into position I.
FR: Insérez l'accoudoir en position I

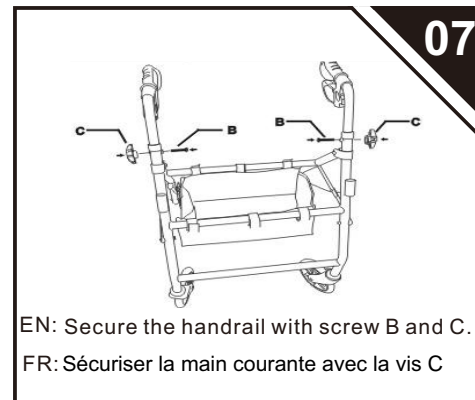

07

EN: Secure the handrail with screw B and C.
FR: Sécuriser la main courante avec la vis C

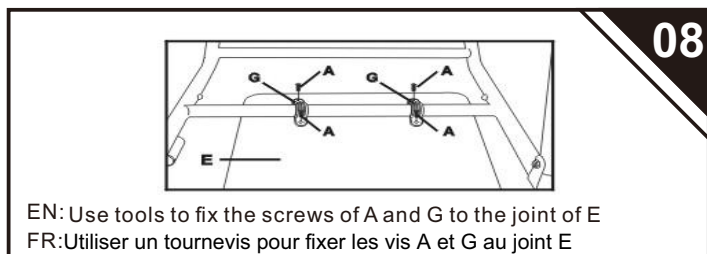

08

EN: Use tools to fix the screws of A and G to the joint of E
FR: Utiliser un tournevis pour fixer les vis A et G au joint E

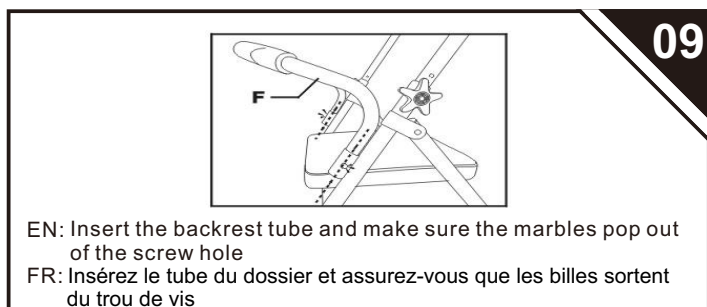

09

EN: Insert the backrest tube and make sure the marbles pop out of the screw hole
FR: Insérez le tube du dossier et assurez-vous que les billes sortent du trou de vis

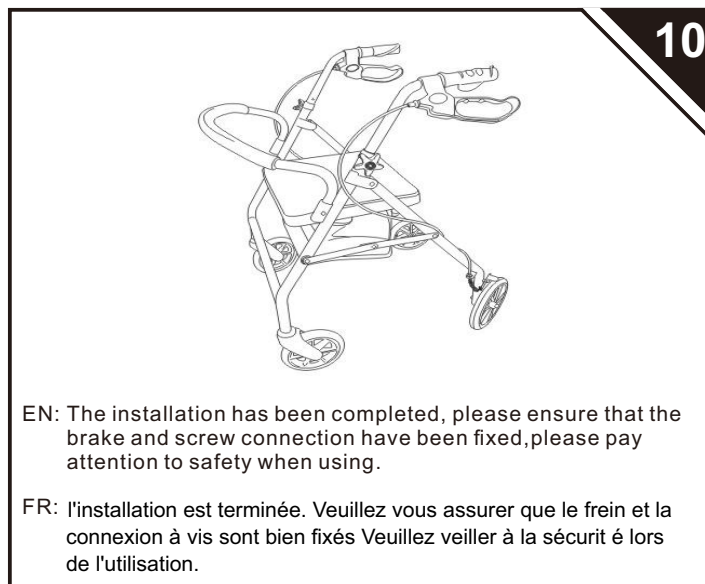

10

EN: The installation has been completed, please ensure that the brake and screw connection have been fixed, please pay attention to safety when using.

FR: l'installation est terminée. Veuillez vous assurer que le frein et la connexion à vis sont bien fixés. Veuillez veiller à la sécurité lors de l'utilisation.

