

PawHut

INdbb088V01_GL

D06-122_D06-123_D06-124

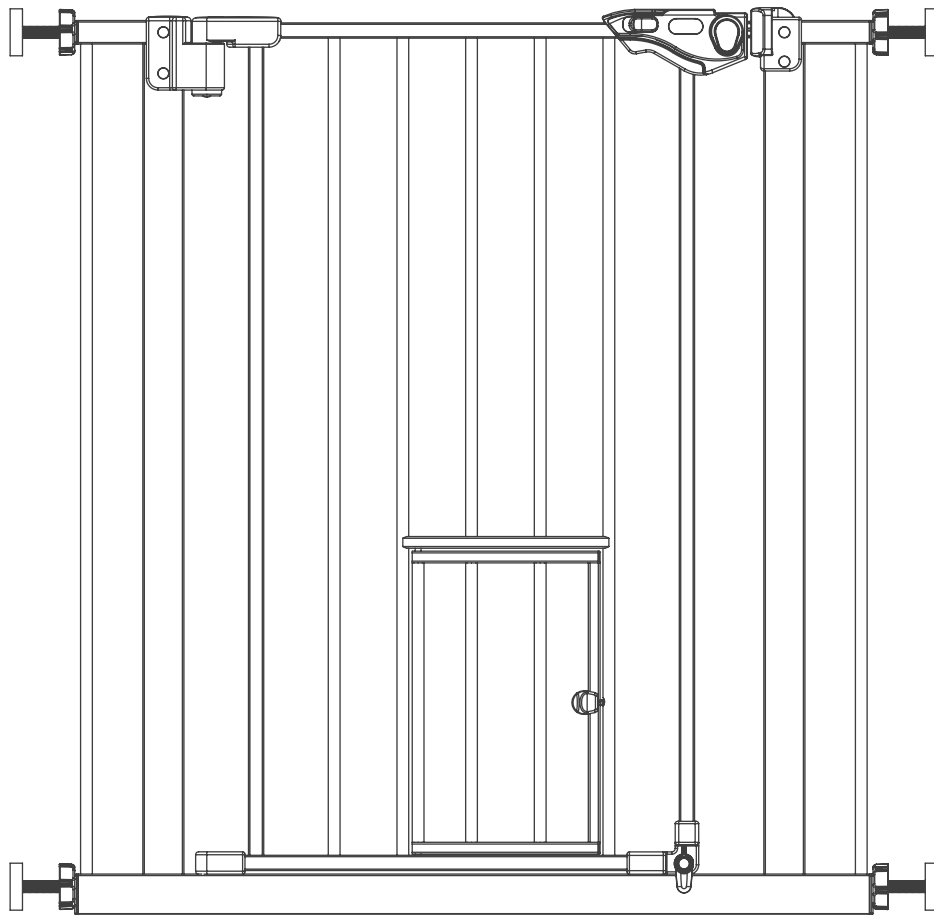

IMPORTANT, RETAIN FOR FUTURE REFERENCE: READ CAREFULLY

ASSEMBLY & INSTRUCTION MANUAL

WARNING

Children have died or been seriously injured when gates are not securely installed.

ALWAYS install and use gates as directed using all required parts.

YOU must install wall cups to keep gate in place. Without wall cups, child can push out and escape.

STOP using when a child can climb over or dislodge the gate.

USE only with the locking mechanism securely engaged.

NEVER use to keep child away from pool.

NEVER leave child unattended.

Intended for use with children between 6 and 24 months. Install according to manufacturer's instructions.

MODEL NO.	No Extension	10cm Extension	15cm Extension	MAX SIZE
D06-122BK	✓			74cm(29in)-79cm(31in)
D06-122WT	✓			74cm(29in)-79cm(31in)
D06-123	✓			74cm(29in)-79cm(31in)
D06-124	✓			74cm(29in)-79cm(31in)

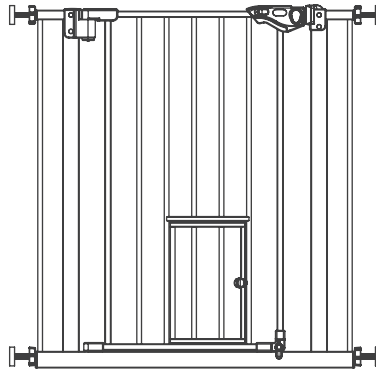

No EXTENSION
74 - 79cm
29-31inch

BEFORE USING PRODUCT

IMPORTANT

Improper installation could result in the gate becoming unstable or dislodged from the doorway.

Base locks are to be used at all times, on both sides of the gate.

This product will not necessarily prevent all accidents.

☐ Check the gate regularly to see if all the hardware and mountings are tightened.

Do not use if any components are missing or damaged.

STOP using when a pet can climb over or dislodge the gate.

Additional or replacement parts should only be obtained from the manufacturer or distributor.

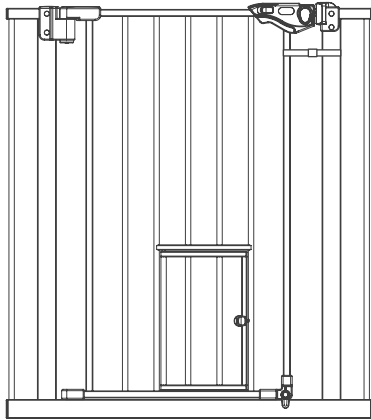
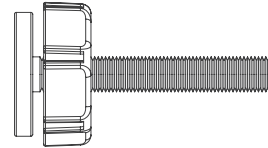
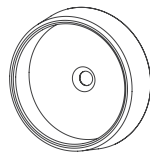
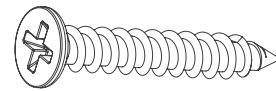
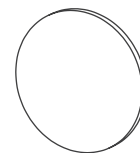
BEFORE ASSEMBLY**A:** Gate Frame (1)**B:** Threaded Spindle
Rods (4)**C:** Wall Cups (4)**D:** Screws (4)**E:** Spanner (1)**F:** Sticker (4)

INSTALLING YOUR GATE

STEP 1

Locate the (4) threaded spindle rods (B). Rotate the adjustment wheels along the threading, eliminating the gap between the adjustment wheel and the rubber foot (*Figure 1-1*)

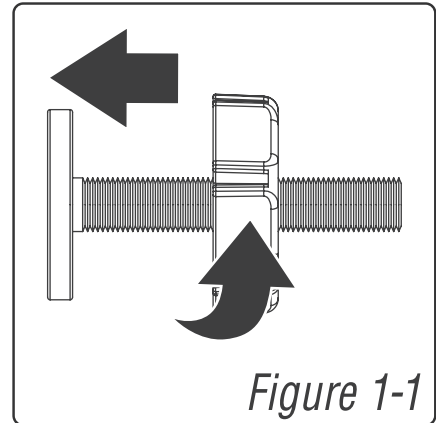

Figure 1-1

NOTE You may notice a slight gap between the gate door latch and the frame (*Figure 1-2*)

THIS IS NOT A DEFECT this gate is a pressure mounted gate and this gap will disappear once you tighten the gate in its opening.

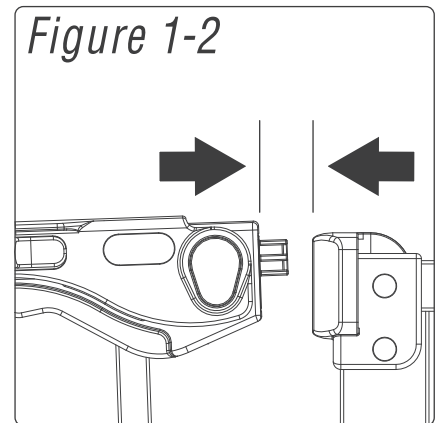
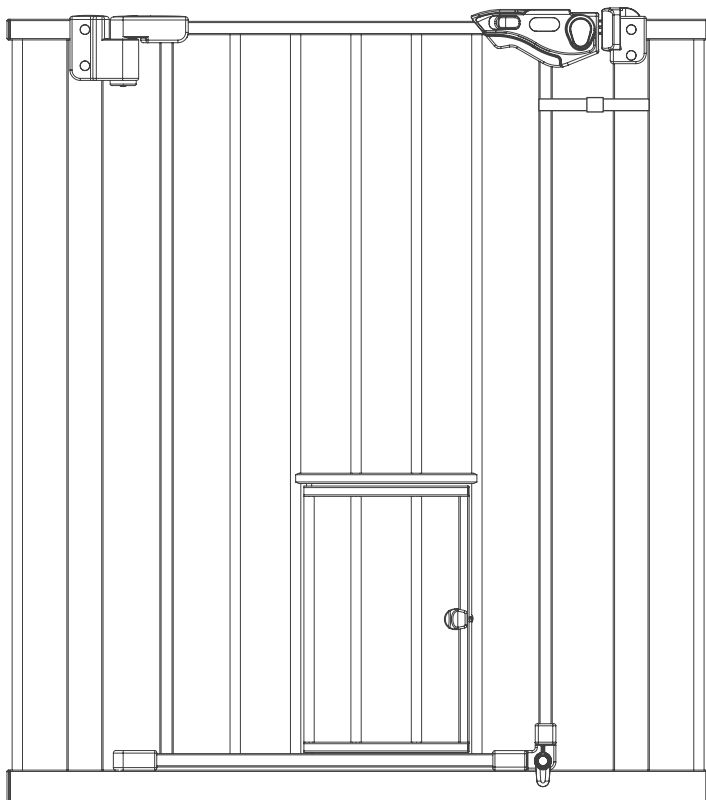

Figure 1-2



DO NOT REMOVE THE ZIP TIE UNTIL INSTALLATION IS COMPLETE.

(Figure 1-3)

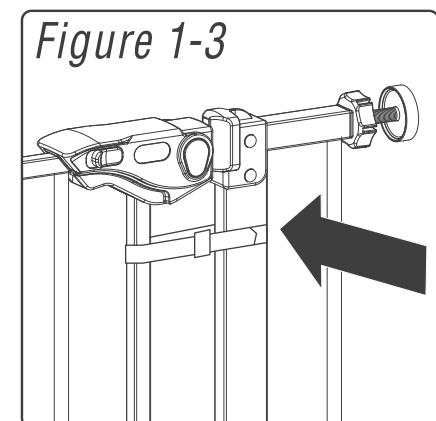
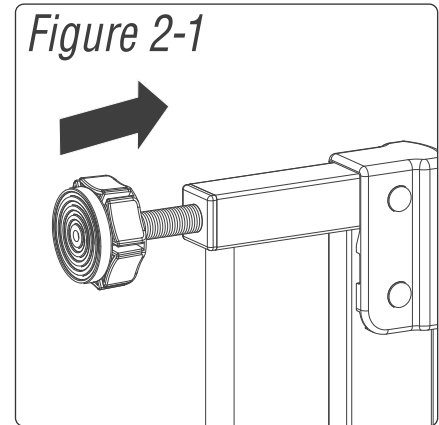

Figure 1-3

STEP 2

Insert the threaded spindle rods with adjustment wheels into the hole on all four corners of the sides of the gate. (Figure 2-1)



Place the gate in desired opening with the bottom close to the floor. The distance between the bottom of the gate and the floor should be less than **1/8 inch (0.3cm)** (Figure 2-2). Once you are satisfied with the placement of your gate trace the spindle rods rubber feet onto the surface of your opening making sure these are level (Figure 2-3) Then remove the gate from the opening. Then screw the 4 wall cups to the wall using the screws (Figure 2-4) or paste the 4 wall cups using the stickers provided (Figure 2-5).

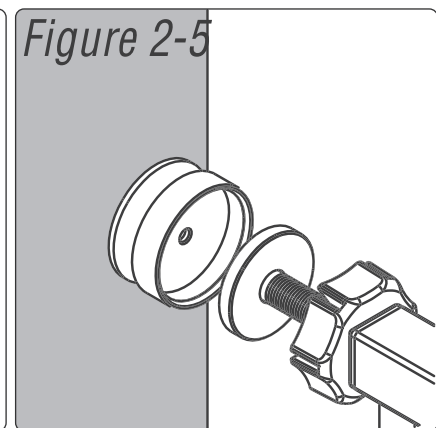
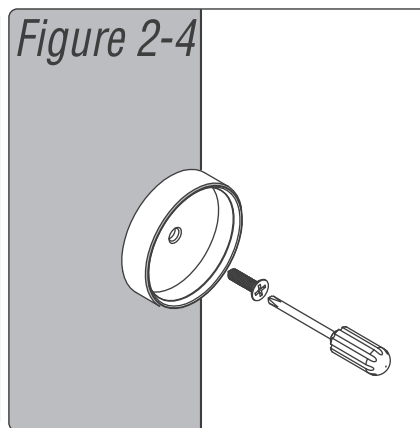
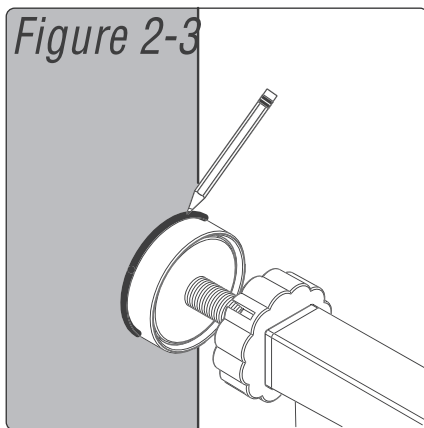
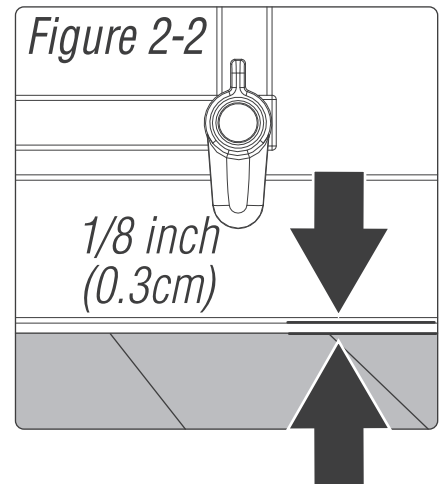

INSTALLING YOUR GATE

STEP 3

Insert all 4 threaded spindle rods into the wall cups (Figure 3-1)
Tighten the wheels using the spanner tool. (Figure 3-2 and Figure 3-3) Do not over tighten. It may be necessary to hold the threaded spindle rods while rotating the adjustment wheels to ensure that the entire unit does not rotate while installing the gate.

NOTE if your door latch is not properly engaging with the receiving component, ensure that your gate is level, mounted properly and that you have not over-tightened the adjustment wheels.

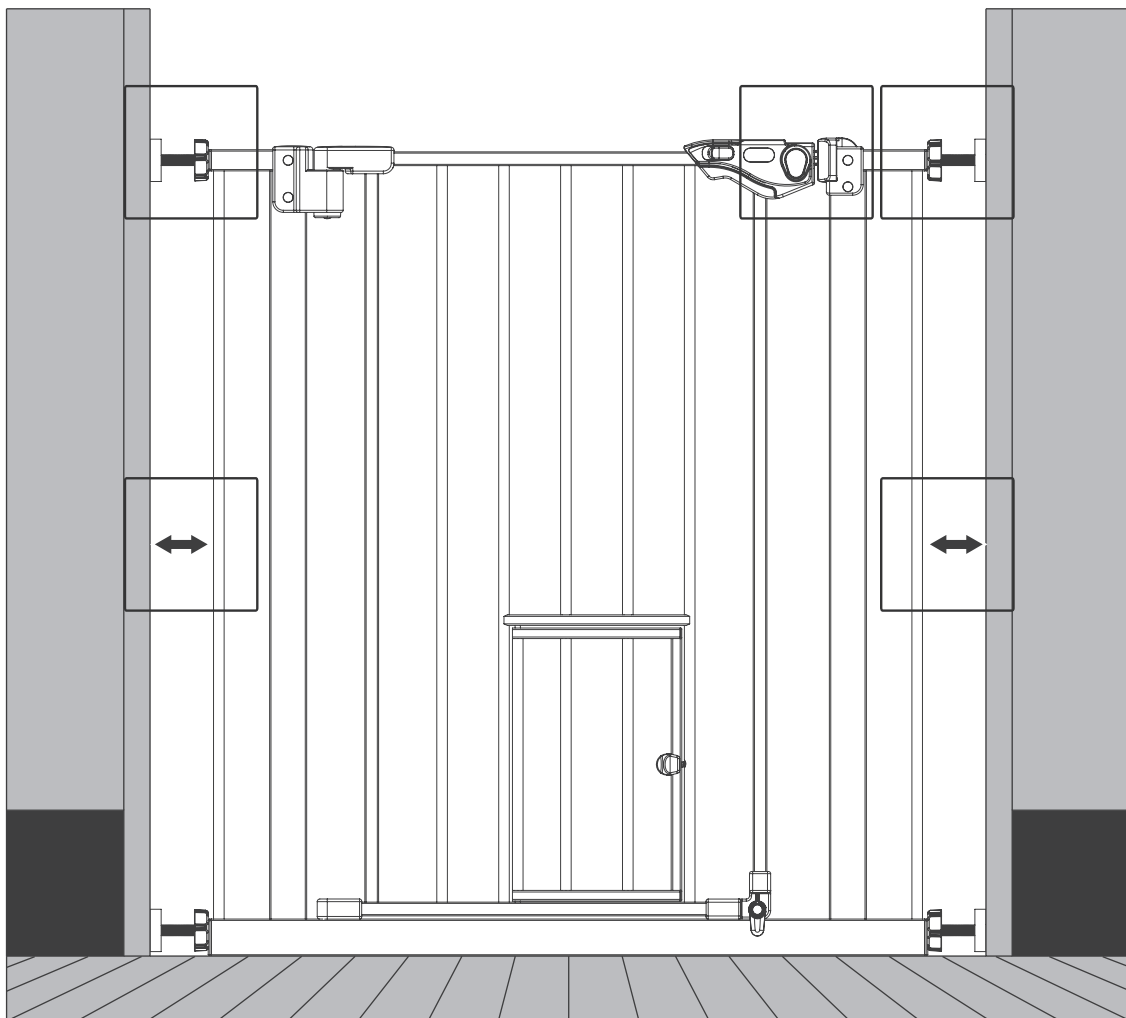

NOTE The gap between the gate and the wall should not exceed more than **2.5 inch(6.3cm)** on either side (*Figure 3-4 and 3-5*)

If the gate has been installed properly the gap between the door latch and frame should now be closed (*Figure 3-6*)

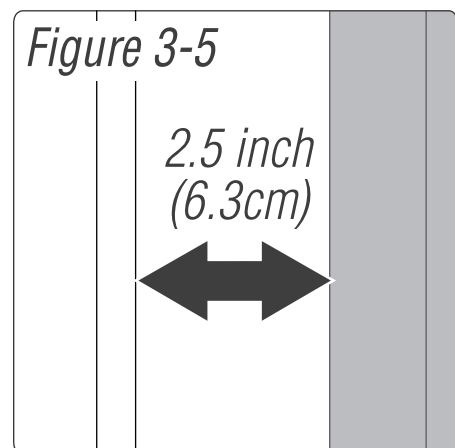
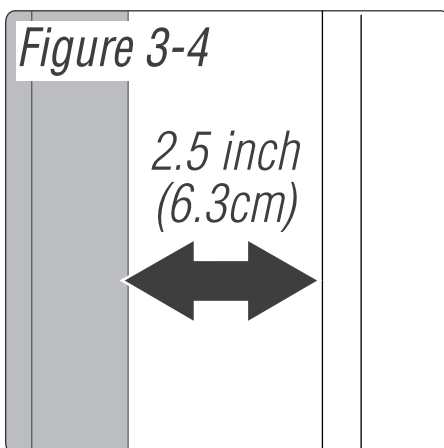
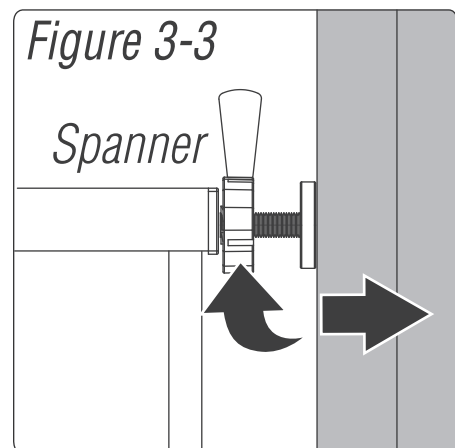
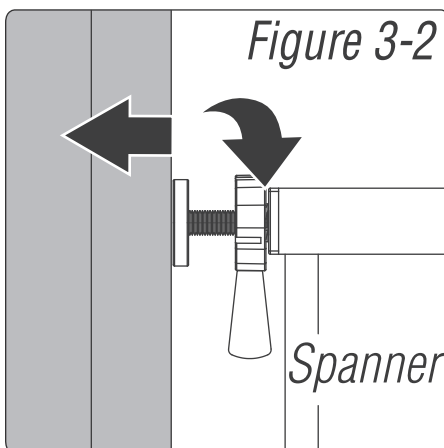
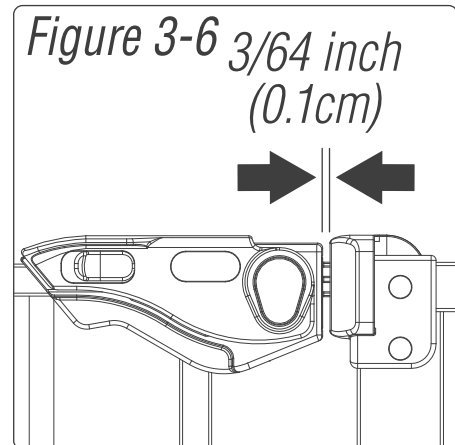
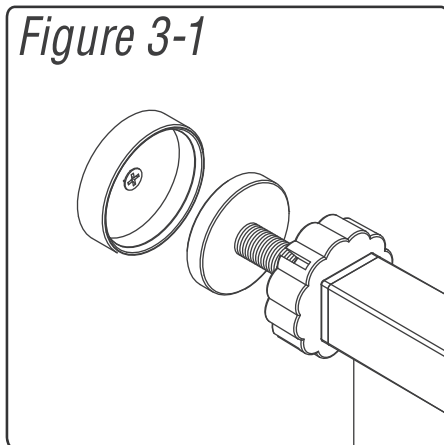

OPERATING THE DOOR LATCH

To Open - Ensure that the base locks at the bottom of the gate door are in the horizontal position (*Figure 4-1*) Pull the spring lock away from the easy open latch while simultaneously lifting the lock lever upwards (*Figure 4-2 and 4-3*). This will release the locking latch from the gate frame and allow the door to push or pull open.

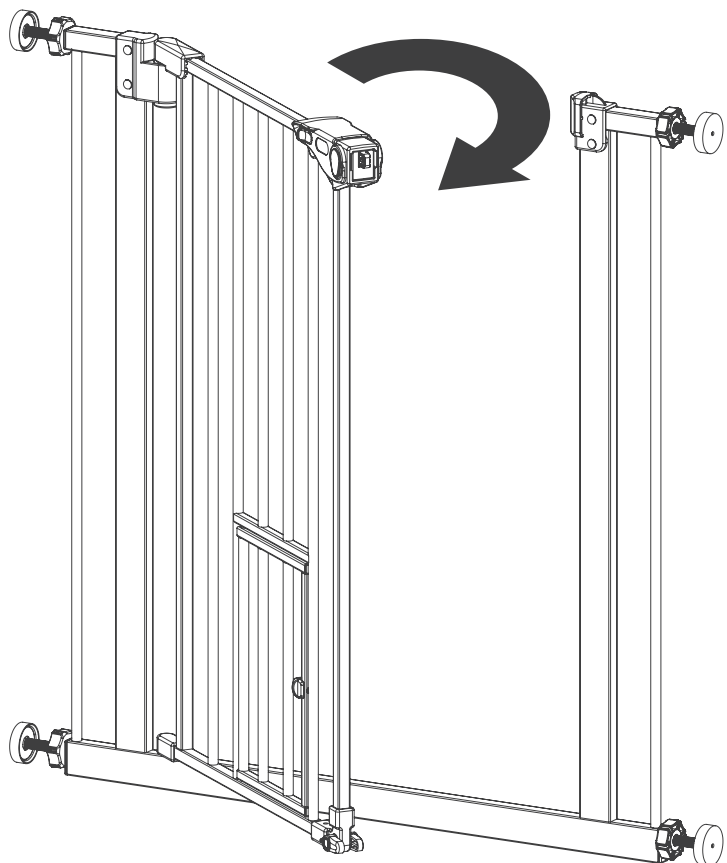
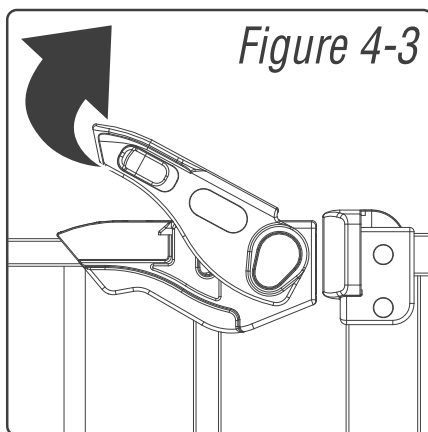
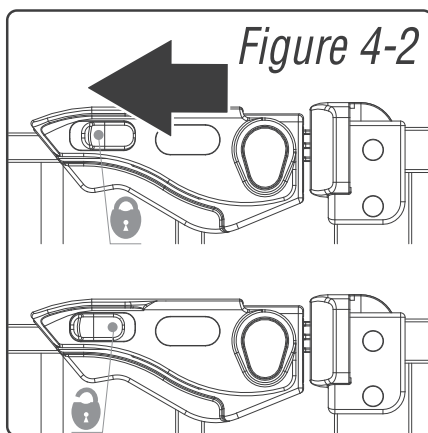
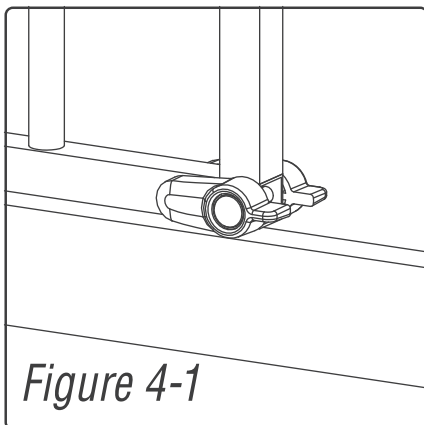

To Close - Pull the door shut and ensure that the door latch on top closes and then place the lock at the bottom of the gate down on the side occupied by the child, Gate will swing both ways unless one of the swing stops is down. Gate will not swing at all if both swing stops are down. (Figure 4-4)

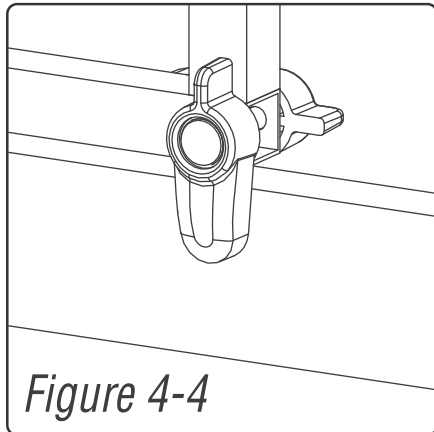

Figure 4-4

Once the gate is opened, it can close up automatically and lock up.

When the opening width of the gate is **8 inch (20cm)**, the gate has the function of Automatic Closing (Figure 4-5)

NOTE When the gate opening width is greater than **23 inch (58cm)**, the gate will be normally open. (Figure 4-6)

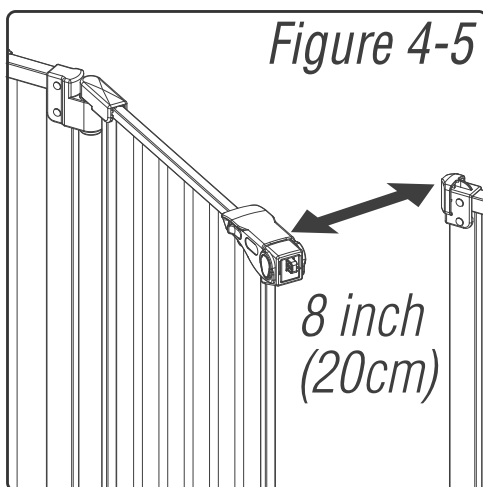

Figure 4-5

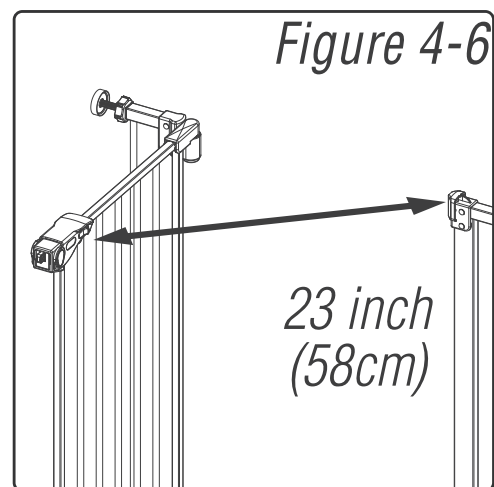
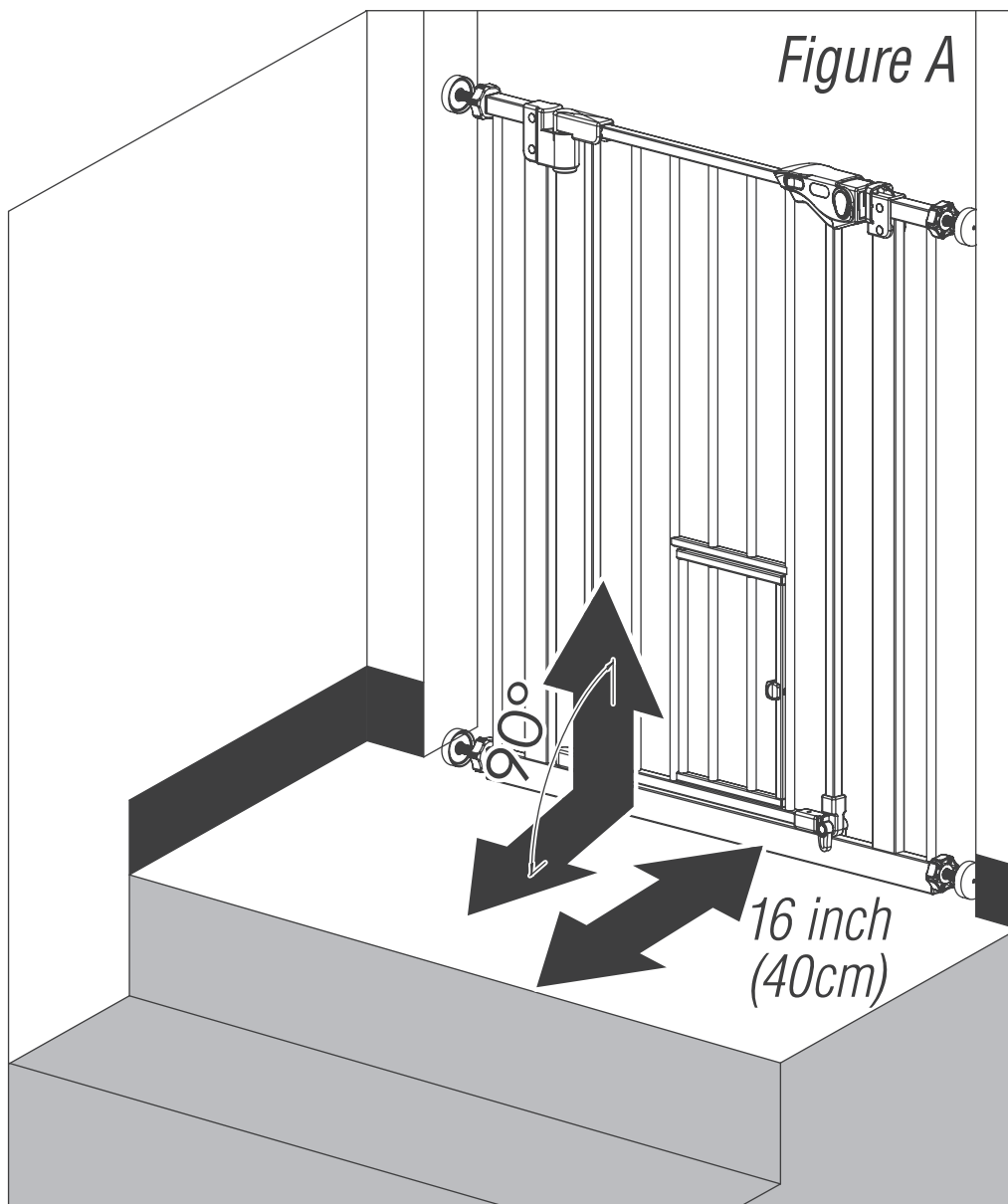

Figure 4-6

USE AT THE TOP OF STAIRS

If the gate is used at the top of stairs, we recommend the safe distance to the 1st step is at least **16 inch(40cm)**.
(Figure A)

Using the wall cups will affix your gate more firmly in the doorway or opening.



OPEN SMALL PET DOOR

To use the small pet door, pull back on the spring pin (*Figure 6-1 and 6-2*).

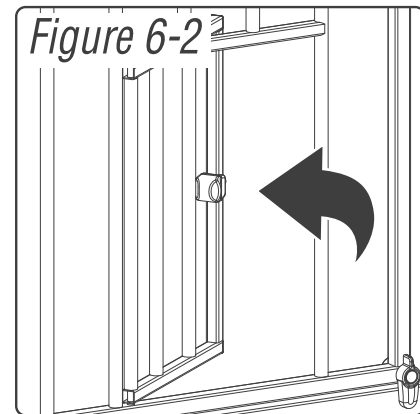
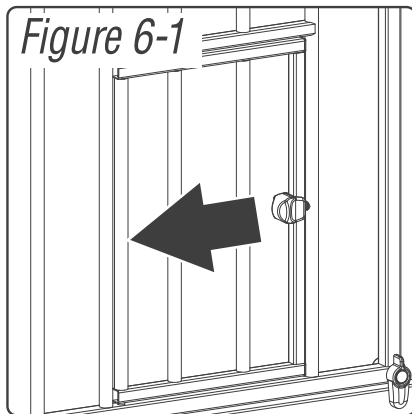

REMOVING YOUR GATE FROM THE WALL

To remove your gate from the wall, rotate the adjustment wheels on each of the (4) threaded spindle rods to depressurize the gate from its doorway or opening. Then, gently pull or push the gate free from its doorway or opening.

CARE AND MAINTENANCE

Periodically check the gate for signs of damage, wear, or missing components. Do not use if any part is missing, worn or damaged. Check the gate regularly to ensure all the hardware and mountings are tightened. Do not use abrasive cleaners or bleach. Clean by sponging with warm water and a mild detergent.



AVERTISSEMENT

Des enfants sont morts ou ont été gravement blessés lorsque les barrières ne sont pas bien installées.

- Installez et utilisez TOUJOURS les barrières comme indiqué en utilisant toutes les pièces requises.
- VOUS devez installer des têtes de fixation pour maintenir la barrière en place. Sans les têtes de fixation, l'enfant peut sortir et s'échapper.
- Cessez d'utiliser la barrière lorsqu'un enfant peut grimper dessus ou déloger la barrière.
- N'utilisez la barrière que si le mécanisme de verrouillage est bien enclenché.
- N'utilisez JAMAIS la barrière pour éloigner l'enfant de la piscine.
- NE LAISSEZ JAMAIS l'enfant sans surveillance.
- Conçu pour être utilisé avec des enfants âgés de 6 à 24 mois.
- Installez selon les instructions du fabricant.

NO. DE MODÈLE	Aucune extension	Extension 10cm	Extension 15cm	TAILLE MAXIMALE
D06-122BK	✓			74cm(29in)-79cm(31in)
D06-122WT	✓			74cm(29in)-79cm(31in)
D06-123	✓			74cm(29in)-79cm(31in)
D06-124	✓			74cm(29in)-79cm(31in)

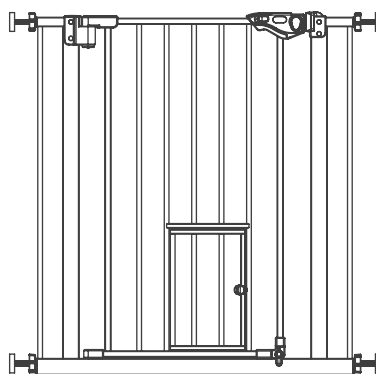

Pas d'EXTENSION
74 - 79cm
29-31inch

AVANT D'UTILISER LE PRODUIT

IMPORTANT

- Une installation incorrecte peut rendre la barrière instable ou déloger la barrière.
- Les verrous de base doivent être utilisées à tout moment des deux côtés de la barrière.
- Ce produit n'empêchera pas nécessairement tous les accidents.
- **Vérifiez régulièrement la barrière pour vous assurer que toutes les pièces et les fixations sont bien serrées.**
- N'utilisez pas l'appareil si des composants sont manquants ou endommagés.
- **ARRÊTEZ** d'utiliser quand un animal de compagnie peut grimper ou déloger la barrière.
- Les pièces supplémentaires ou de rechange doivent être obtenues uniquement auprès du fabricant ou du distributeur.

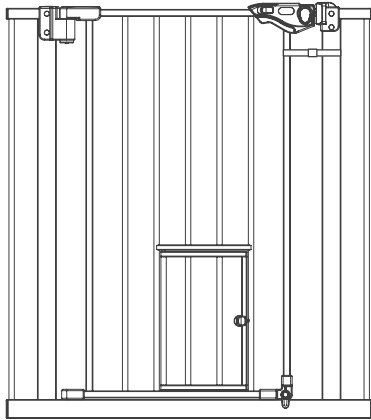
BEFORE ASSEMBLY

A: Cadre de barrière (1)

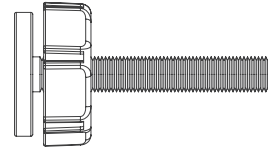

B: Tiges filetées (4)

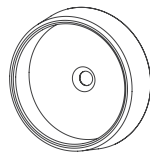

C: Tête de fixation (4)

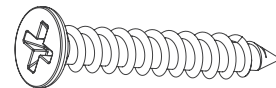

D: Vis (4)



E: Clé (1)

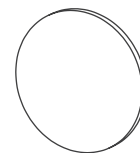

F: Autocollant (4)

INSTALLATION DE VOTRE BARRIÈRE

ÉTAPE 1

Localisez-les (4) tiges filetées (B). Faites tourner les roues de réglage le long du filetage, en éliminant l'espace entre la roue de réglage et le pied en caoutchouc (*Figure 1-1*).

NOTE: Vous remarquerez peut-être un léger espace entre le loquet de porte et le cadre (*Figure 1-2*).

IL NE S'AGIT PAS D'UN DÉFAUT.

Cette barrière est une barrière montée sur pression et cet espace disparaîtra une fois que vous aurez serré la barrière dans son ouverture.

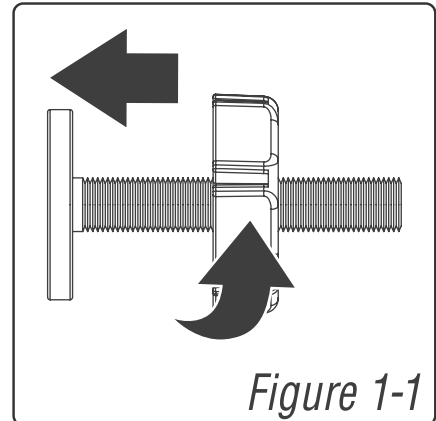

Figure 1-1

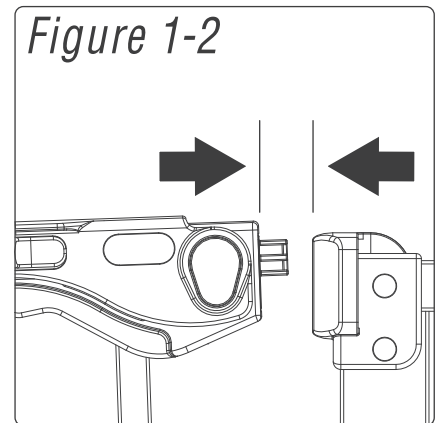
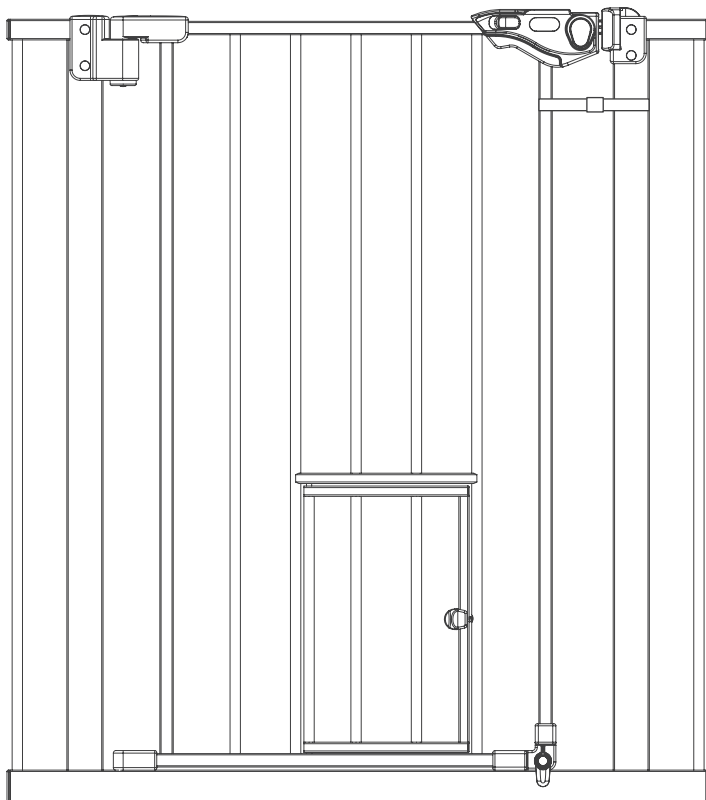

Figure 1-2



NE RETIREZ PAS L'ATTACHE ZIP AVANT QUE L'INSTALLATION SOIT COMPLÈTE (*Figure 1-3*).

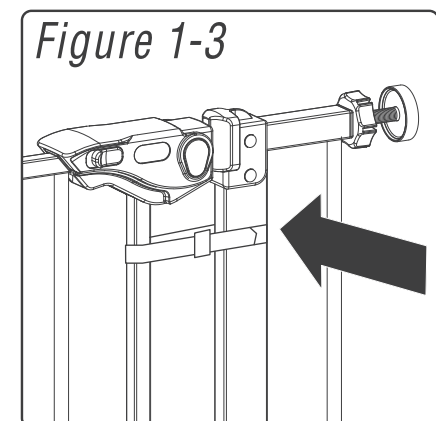

Figure 1-3

ÉTAPE 2

Insérez les tiges filetées ans le trou des quatre coins des côtés de la barrière. (Figure 2-1)

1/8 pouce Placez la barrière dans l'ouverture souhaitée avec le fond près du sol. La distance entre le bas de la barrière et le sol doit être inférieure à **1/8 pouce (0,3cm)** (Figure 2-2). Une fois que vous êtes satisfait du placement de votre barrière, tracez les pieds en caoutchouc des tiges filetées sur la surface de votre ouverture en s'assurant qu'ils sont de niveau (Figure 2-3). Retirez ensuite la barrière de l'ouverture. Vissez ensuite les 4 têtes de fixation au mur à l'aide des vis (Figure 2-4), ou collez les 4 têtes de fixation à l'aide des autocollants fournis (Figure 2-5).

Figure 2-1

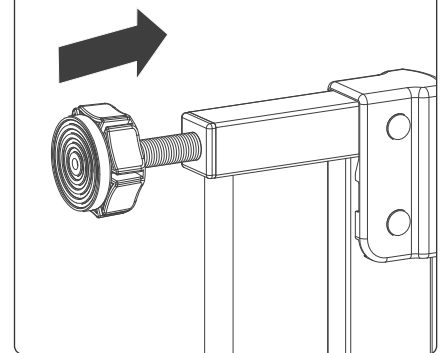

Figure 2-2

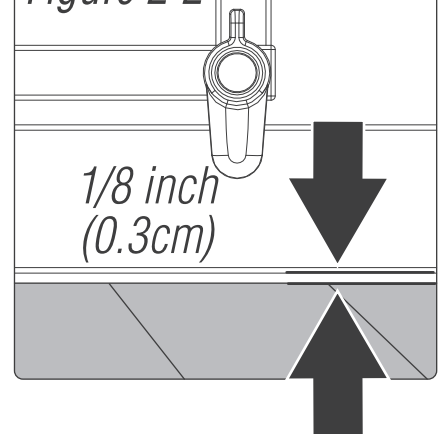

Figure 2-3

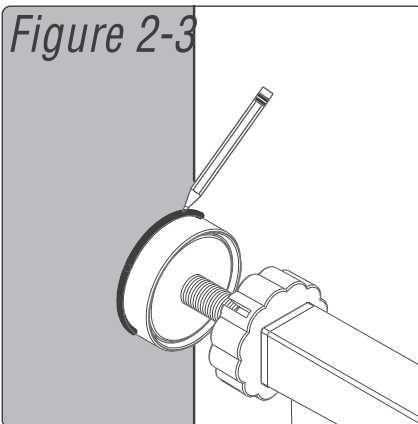

Figure 2-4

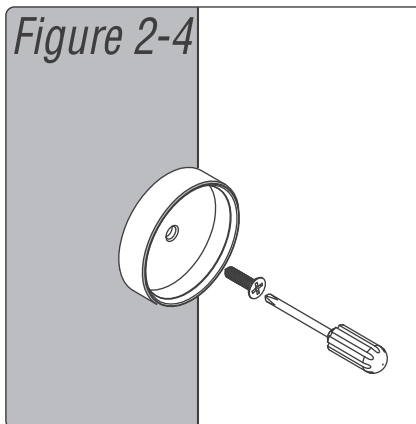
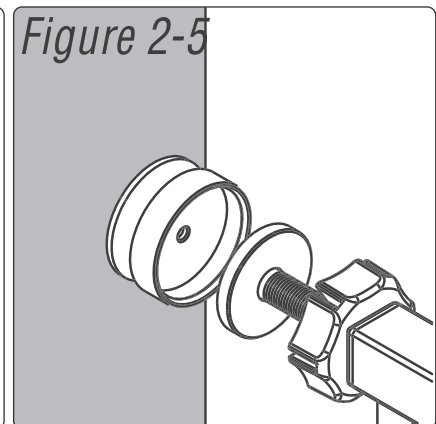

Figure 2-5



INSTALLATION DE VOTRE BARRIÈRE

ÉTAPE 3

Insérez les 4 tiges filetées dans les gobelets muraux (*Figure 3-1*). Serrez les roues à l'aide de l'outil clé. (*Figure 3-2 et Figure 3-3*) Ne pas trop serrer. Il peut être nécessaire de maintenir les tiges filetées tout en faisant pivoter les roues de réglage pour s'assurer que l'ensemble de l'appareil ne tourne pas lors de l'installation de la barrière. **CléNOTE: Si le loquet de porte ne s'engage pas correctement avec le composant de réception, veuillez à ce que votre barrière est de niveau, montée correctement et que vous n'avez pas trop serré les roues de réglage.**

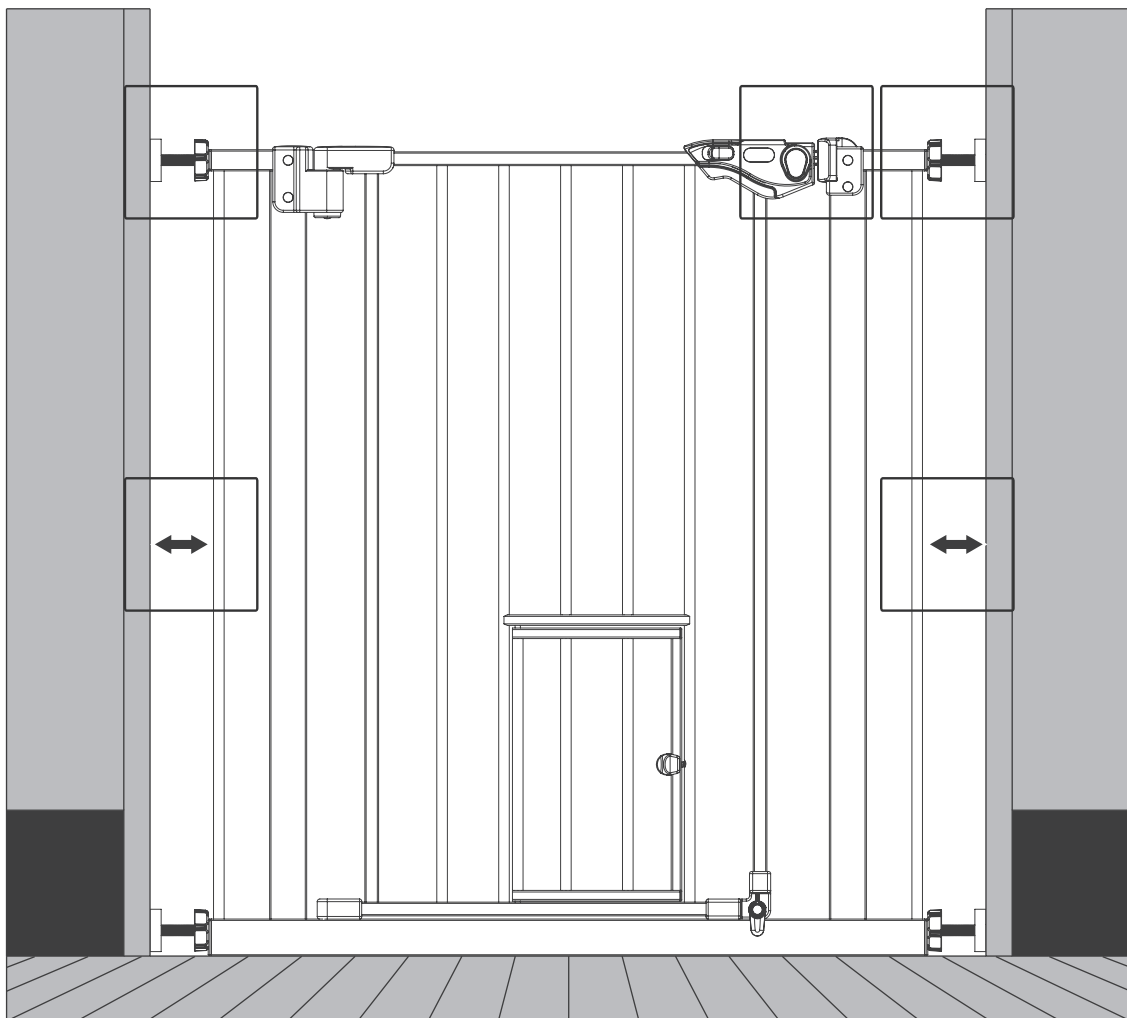

NOTE L'écart entre la barrière et le mur ne doit pas dépasser 2,5 pouces (6,3 cm) de chaque côté (Figures 3-4 et 3-5).
Si la barrière a été installée correctement, l'espace entre le loquet de porte et le cadre doit maintenant être fermé (Figure 3-6).

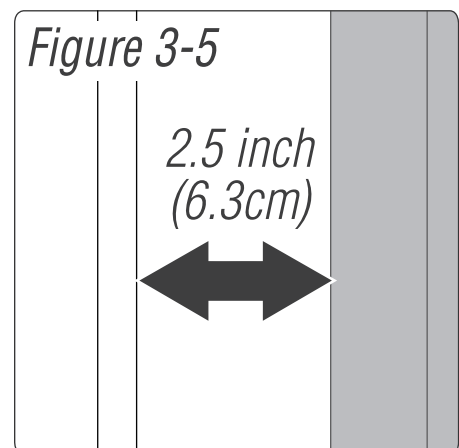
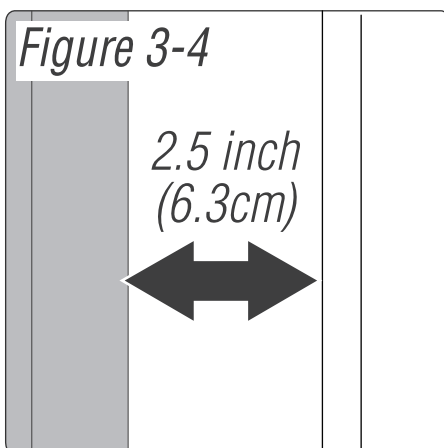
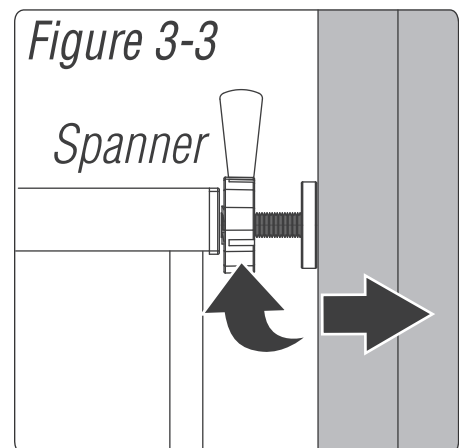
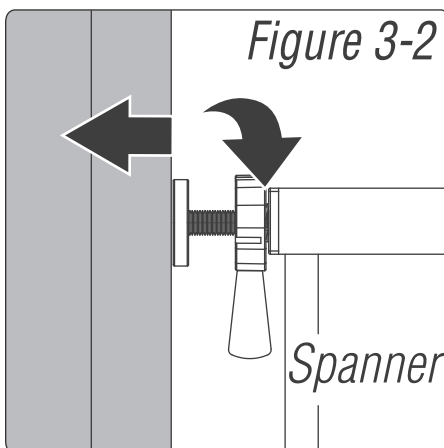
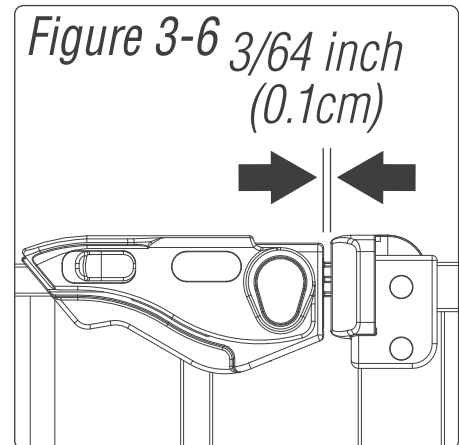
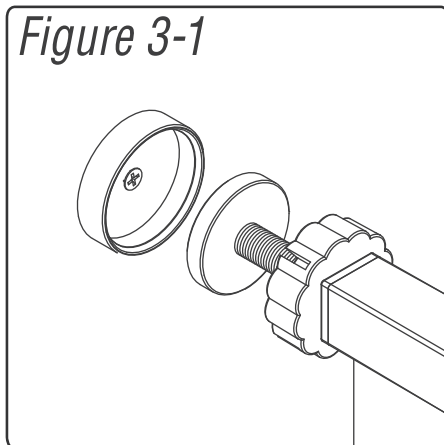

FONCTIONNEMENT DU LOQUET DE BARRIÈRE

Pour ouvrir – Veillez à ce que les verrous de base au bas de la porte de la barrière sont en position horizontale (*Figure 4-1*). Éloignez le verrou à ressort du loquet ouvert facile tout en soulevant simultanément le levier de verrouillage vers le haut (*Figures 4-2 et 4-3*). Cela libérera le loquet de verrouillage du cadre de la barrière et permettra de pousser ou tirer la porte pour l'ouvrir.

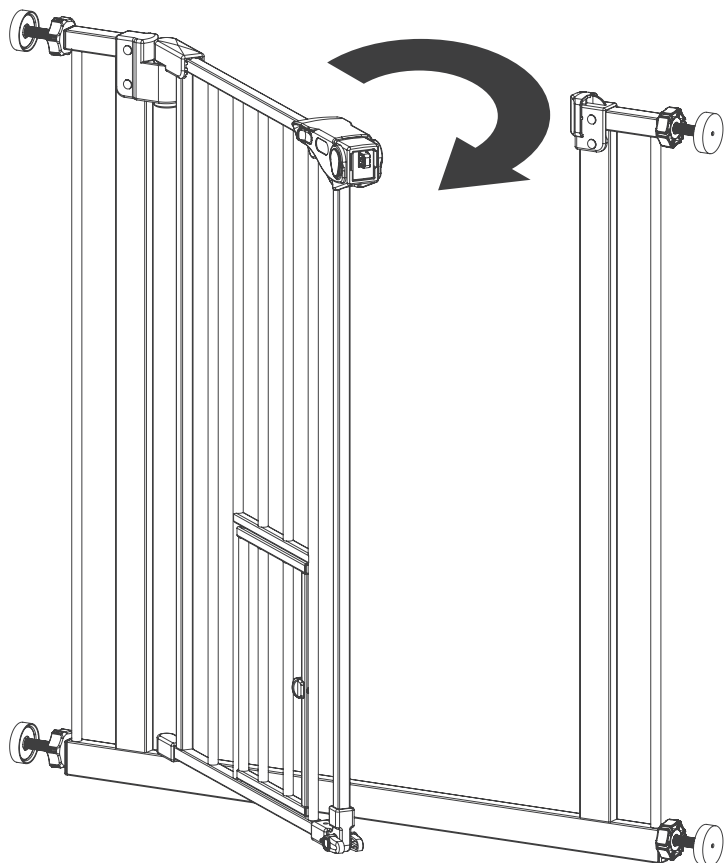
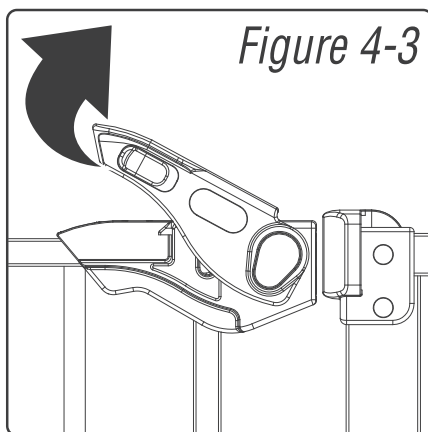
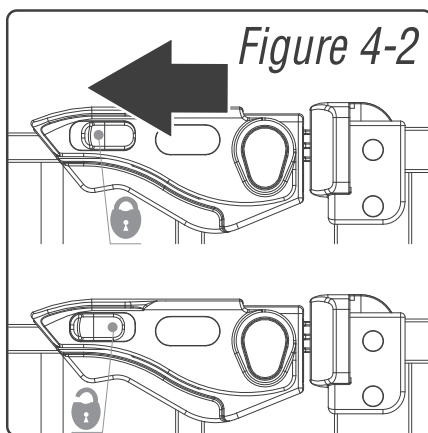
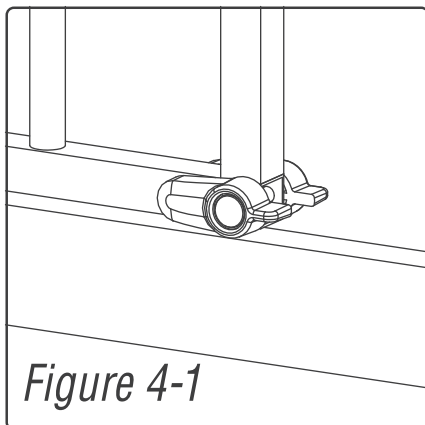

Pour fermer - Tirez la porte fermée et veillez à ce que le loquet de porte sur le dessus se ferme, puis placez le verrou au bas de la barrière sur le côté occupé par l'enfant. La barrière se balancera dans les deux sens à moins que l'une des butées est abaissée. Sauf si l'une des butées est abaissée. La barrière ne se balancera pas du tout si les deux butées sont abaissées (*Figure 4-4*).

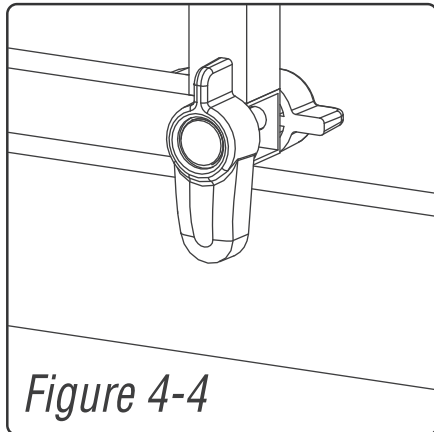

Figure 4-4

Une fois la barrière ouverte, elle peut se fermer automatiquement et se verrouiller.

Lorsque la largeur d'ouverture de la barrière est de **8 pouces (20cm)**, la barrière a la fonction de fermeture automatique (*Figure 4-5*).

NOTE: Lorsque la largeur d'ouverture de la barrière est supérieure à **23 pouces (58 cm)**, la barrière sera normalement ouverte. (*Figure 4-6*)

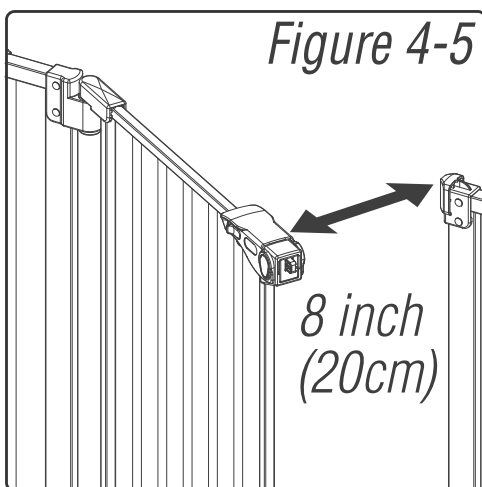

Figure 4-5

*8 inch
(20cm)*

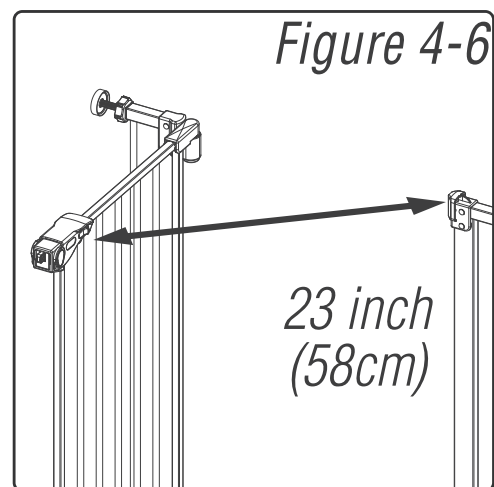

Figure 4-6

*23 inch
(58cm)*

UTILISATION EN HAUT DES ESCALIERS

Si la barrière est utilisée en haut des escaliers, nous recommandons que la distance de sécurité par rapport à la première marche soit d'au moins **16 pouces (40 cm)**. (*Figure A*)

L'utilisation des têtes de fixation permet de fixer plus fermement votre barrière dans l'embrasure ou l'ouverture de la barrière.

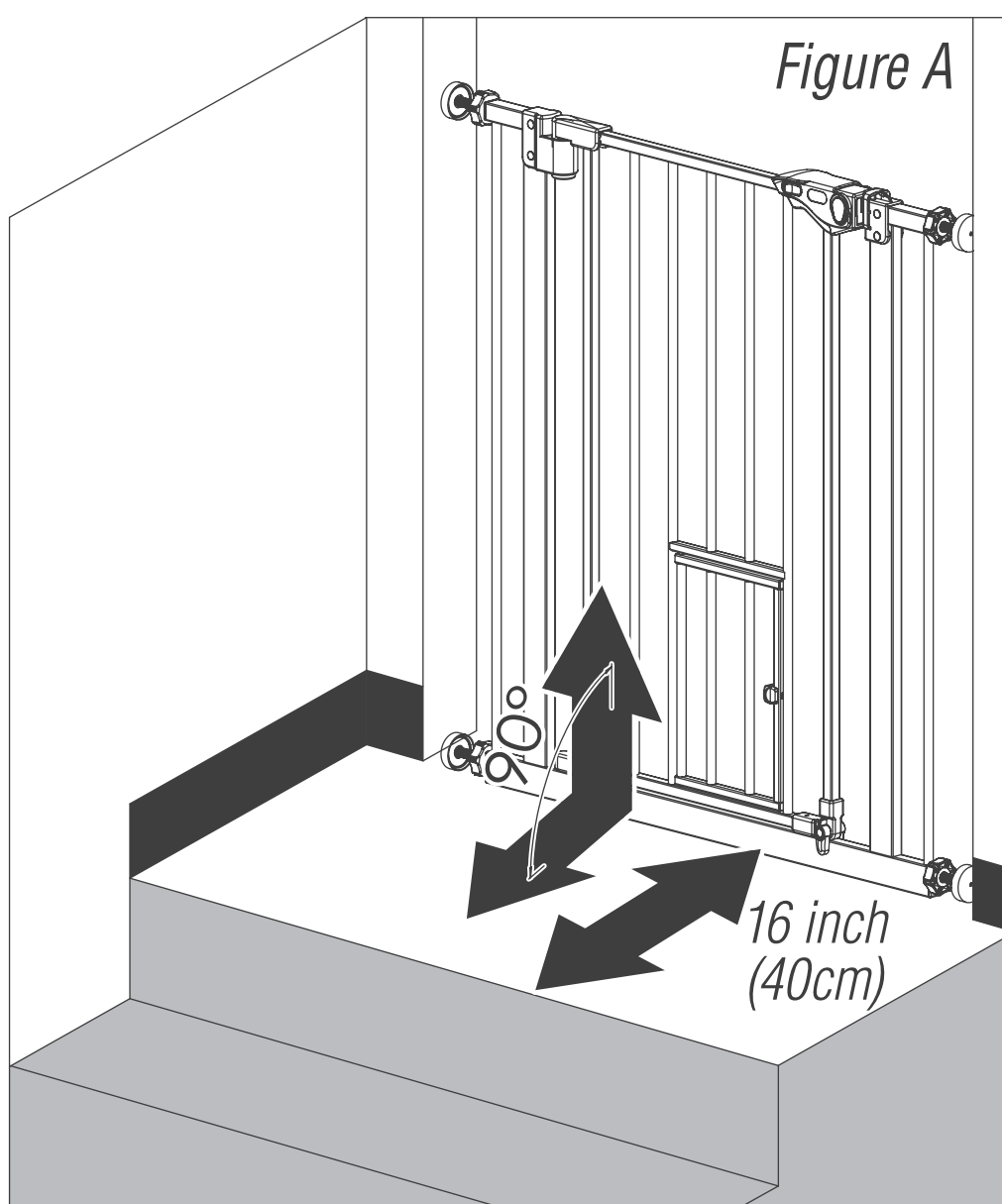

PETITE PORTE POUR ANIMAUX DE COMPAGNIE

Pour utiliser la petite porte pour animaux de compagnie, tirez sur la goupille à ressort (*Figure 6-1 et 6-2*).

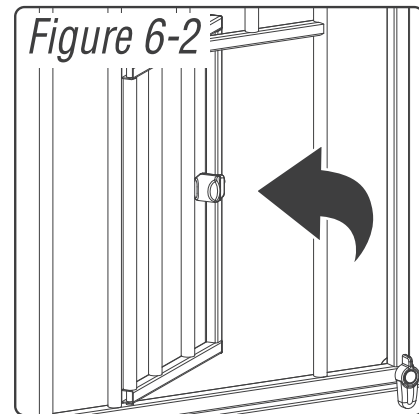
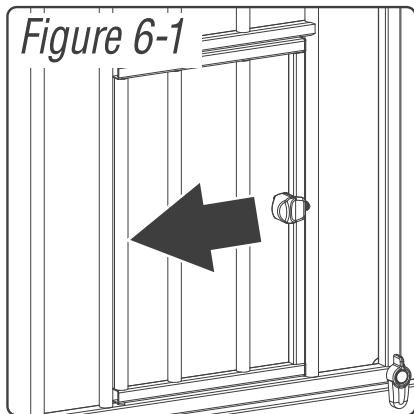

RETIRER VOTRE BARRIÈRE DU MUR

Pour retirer votre barrière du mur, tournez les roues de réglage sur chacune des (4) tiges filetées pour dépressuriser la barrière de son entrée ou de son ouverture. Ensuite, tirez ou poussez doucement la barrière pour la libérer de son entrée ou de son ouverture.

ENTRETIEN ET ENTRETIEN

Vérifiez périodiquement que la barrière ne présente pas de signes de dommages, d'usure ou de composants manquants. N'utilisez pas la barrière si une pièce est manquante, usée ou endommagée. Vérifiez régulièrement la barrière pour vous assurer que toute la quincaillerie et les fixations sont bien serrées. N'utilisez pas de nettoyants abrasifs ni d'eau de Javel. Nettoyez en épongeant avec de l'eau tiède et un détergent doux.



ADVERTENCIA

Existen peligros de muerte o heridas graves para los niños si las puertas no están instaladas de forma segura.

SIEMPRE instale y use las puertas como se indica usando todas las partes previstas.

USTED debe instalar las ventosas de pared para mantener la puerta en su lugar. Sin las ventosas de pared, el niño puede empujar la puerta y salir por ella.

DEJE de usarla cuando un niño pueda trepar o salir por la puerta cerrada.

UTILÍCELA sólo con el mecanismo de bloqueo enganchado de forma segura.

NUNCA la use para mantener a los niños alejados de la piscina.

NUNCA deje al niño sin supervisión.

Destinado a los niños de 6 y 24 meses.

Instálela de acuerdo con las instrucciones del fabricante.

NO. DE MODELO	Sin Extensión	Extensión de 10cm	Extensión de 15cm	TAMAÑO MÁXIMO
D06-122BK	✓			74cm(29in)-79cm(31in)
D06-122WT	✓			74cm(29in)-79cm(31in)
D06-123	✓			74cm(29in)-79cm(31in)
D06-124	✓			74cm(29in)-79cm(31in)

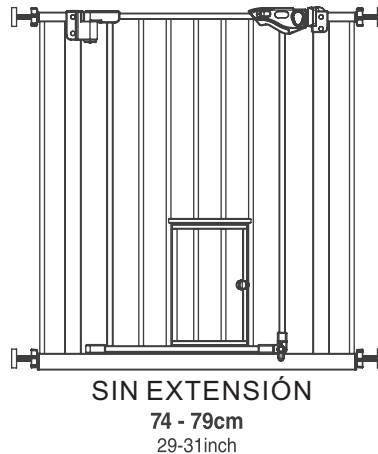

ANTES DE UTILIZAR EL PRODUCTO

IMPORTANTE

La instalación incorrecta podría provocar la inestabilidad de puerta o su caída del acceso.

Las cerraduras de la base deben usarse en todo momento, en ambos lados de la puerta.

Este producto no puede evitar todos los accidentes.

Revise la puerta con regularidad para ver si todos los herrajes y montajes están apretados.

No la utilice si falta algún componente o está dañado.

DEJE de usarla cuando una mascota pueda trepar o salir por la puerta cerrada.

Las piezas adicionales o de repuesto sólo deben obtenerse del fabricante o distribuidor.

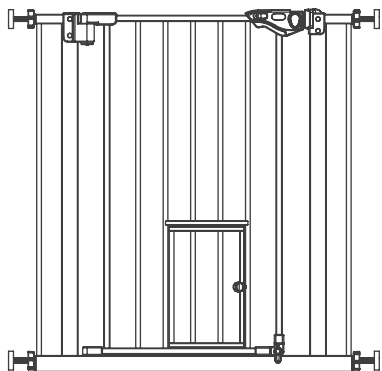
ANTES DEL MONTAJE

A: Marco de Puerta (1)

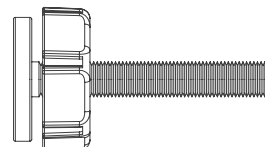

B: Varillas Roscadas (4)

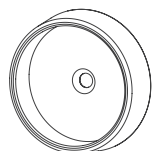

C: Ventosas de Pared(4)

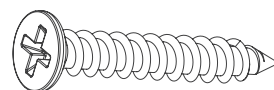

D: Tornillos (4)



E: Llave (1)

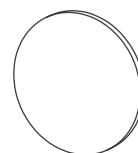

F: Pegatina (4)

INSTALACIÓN DE SU PUERTA

PASO 1

Localice las (4) varillas roscadas (B). Gire los volantes de ajuste a lo largo del roscado, eliminando el espacio entre el volante de ajuste y la pata de goma (*Figura 1-1*).

NOTA Puede existir un pequeño espacio entre el pestillo de la puerta y el marco (*Figura 1-2*).

ESTO NO ES UN DEFECTO. Esta puerta se monta a presión y este espacio desaparecerá una vez que apriete la puerta en su abertura.



Figura 1-1



Figura 1-2

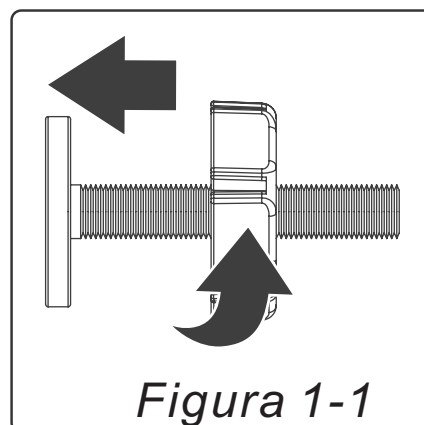

NO RETIRE EL SUJETADOR DE SEGURIDAD HASTA QUE LA INSTALACIÓN ESTÉ COMPLETA.
(*Figura 1-3*)

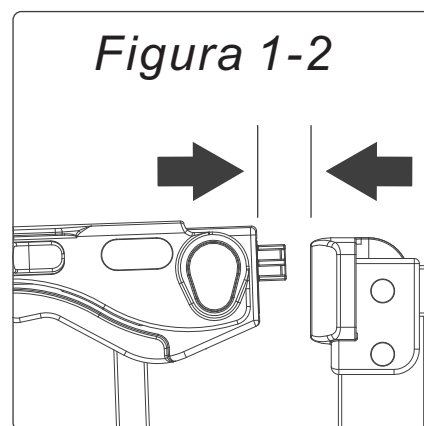
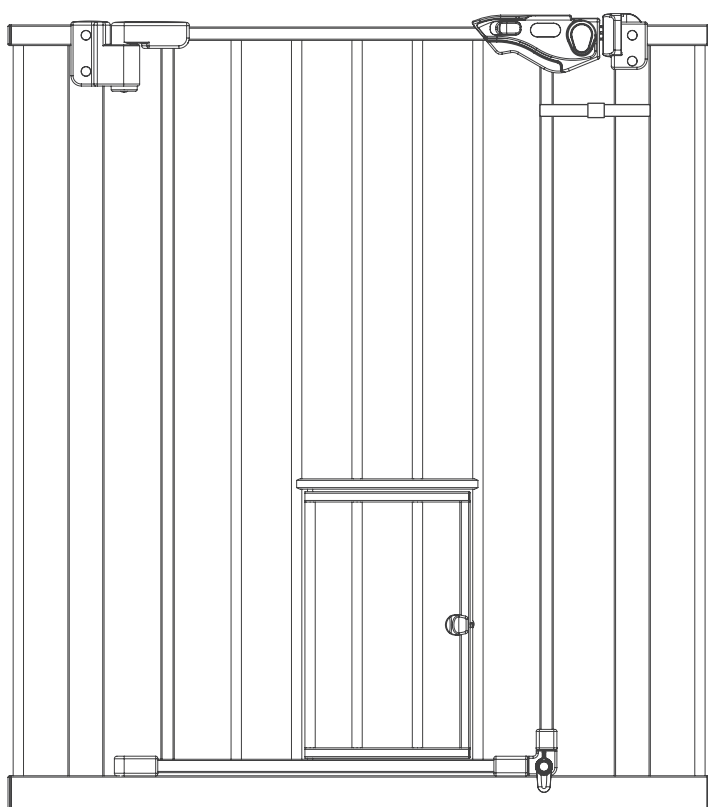

Figura 1-3

PASO 2

Inserte las varillas roscadas con volantes de ajuste en el orificio en las cuatro esquinas de los lados de la puerta. (*Figura 2-1*)

Coloque la puerta con distancia deseada al piso en la parte inferior. La distancia entre la parte inferior de la puerta y el piso debe ser inferior a 1/8 de pulgada (0,3 cm) (*Figura 2-2*). Una vez que esté satisfecho con la ubicación de su puerta, mueve las patas de goma de las varillas sobre la superficie de su abertura, asegurándose de que estén niveladas (*Figura 2-3*). Luego retire la puerta de la abertura. Luego, atornille las 4 ventosas de pared a la pared con los tornillos (*Figura 2-4*), o pegue las 4 ventosas de pared con las pegatinas provistas (*Figura 2-5*).

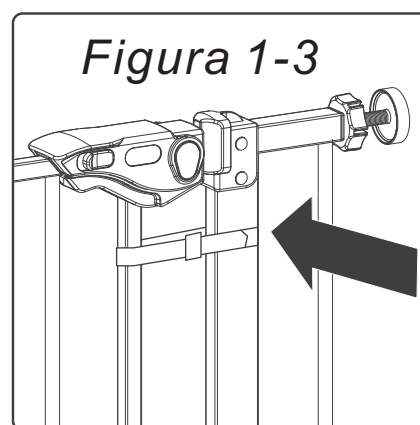
Figura 2-1



Figura 2-2



Figura 2-3

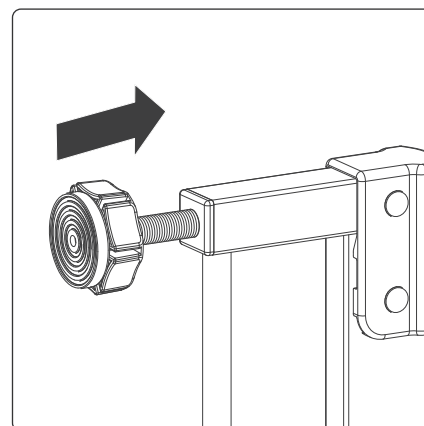

Figura 2-4

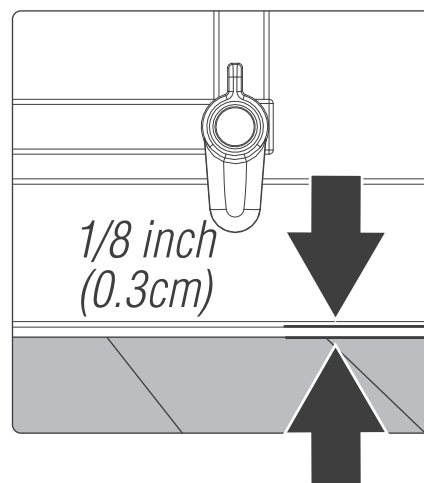

Figura 2-5

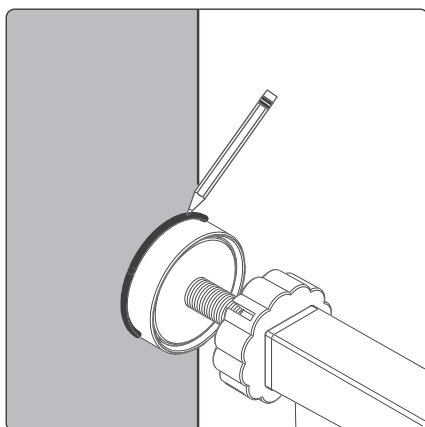

INSTALACIÓN DE SU PUERTA

PASO 3

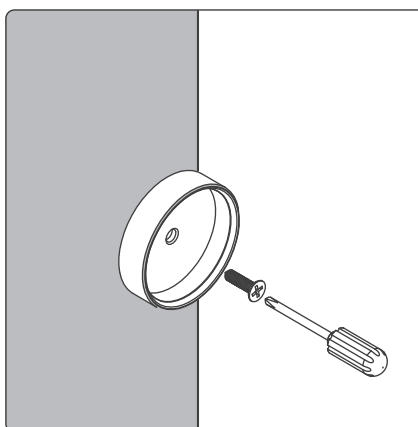
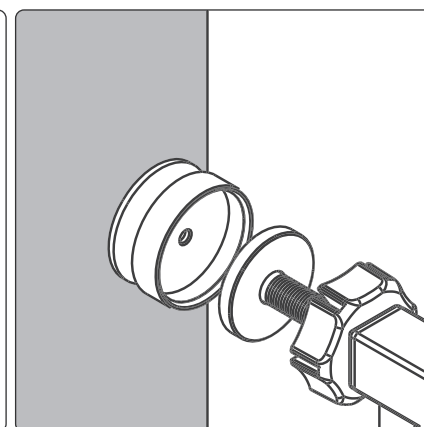
Inserte las 4 varillas roscadas en las ventosas de pared (Figura 3-1). Apriete los volantes con la llave inglesa. (Figura 3-2 y Figura 3-3) No los apriete demasiado. Es necesario sujetar las varillas roscadas mientras se giran los volantes de ajuste para asegurarse de que toda la unidad no gire al instalar la puerta.

NOTA: si el pestillo de la puerta no se acopla correctamente con el componente correspondientes, asegúrese de que la puerta esté nivelada, montada correctamente y que no haya apretado demasiado los volantes de ajuste.

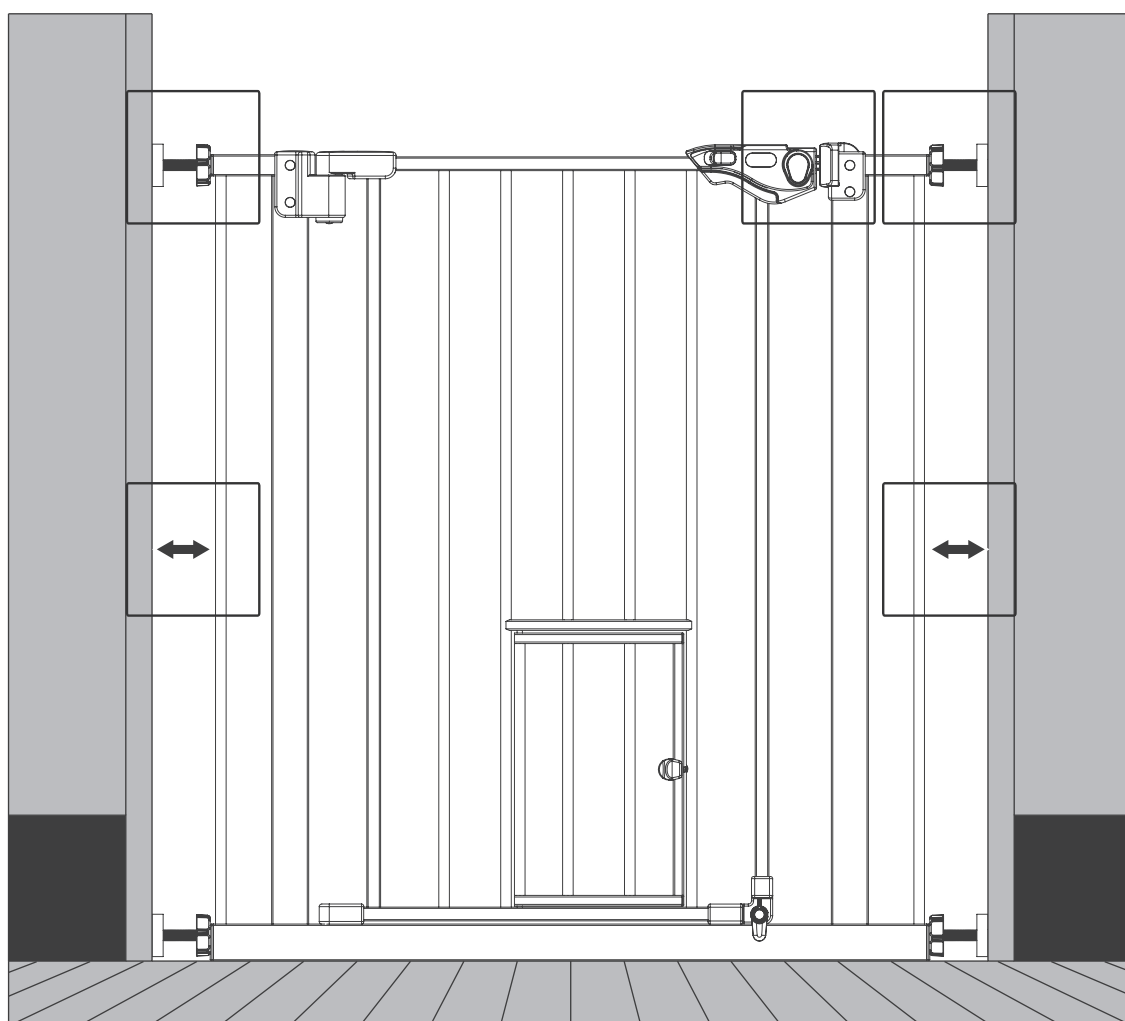

NOTA El espacio entre la puerta y la pared a cada lado no debe exceder más de 2,5 pulgadas (6,3 cm) (Figura 3-4 y 3-5)

Si la puerta se ha instalado correctamente, no hay espacio entre el pestillo de la puerta y el marco (Figura 3-6)

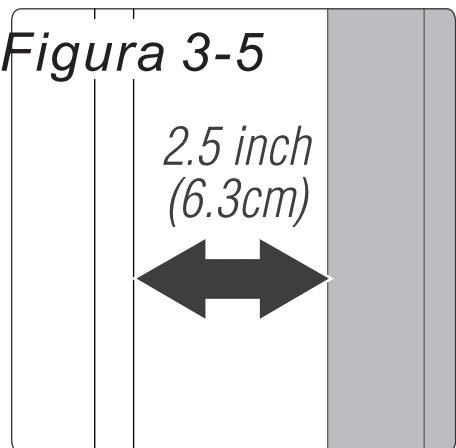
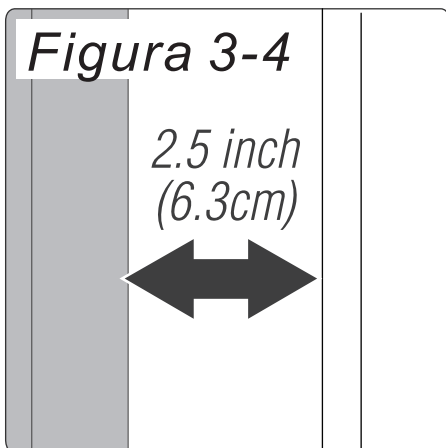
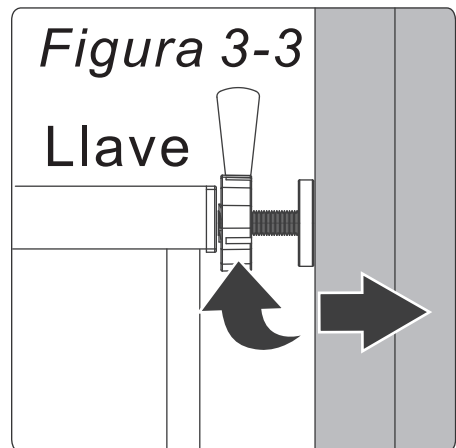
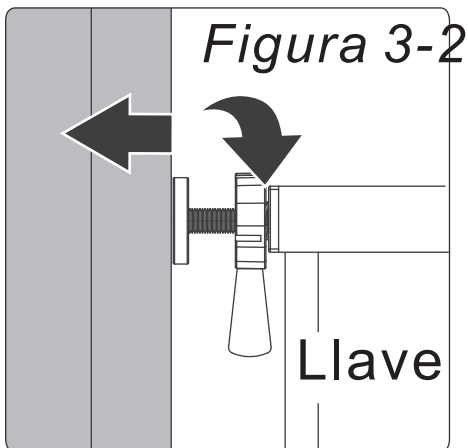
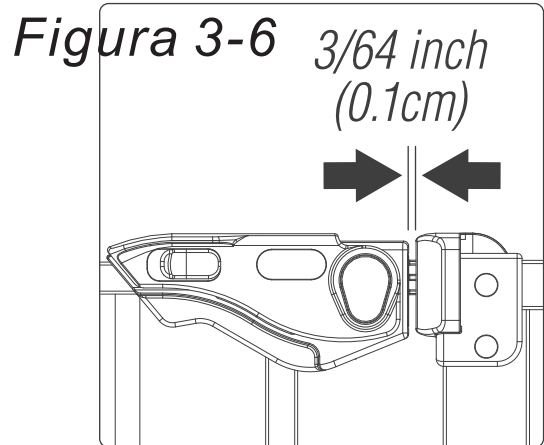
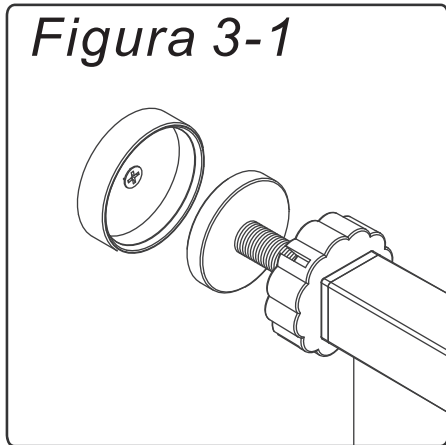

OPERACION DEL PESTILLO

DE LA PUERTA

Para abrir la puerta: asegúrese de que las cerraduras de la base en la parte inferior de la puerta estén en posición horizontal (*Figura 4-1*). Tire del bloqueo de resorte para separarlo del pestillo de apertura simple y, al mismo tiempo, levante la palanca de bloqueo hacia arriba (*Figura 4-2 y 4-3*). Esto liberará el pestillo de bloqueo del marco de la puerta y permitirá que la puerta se empuje o se abra.

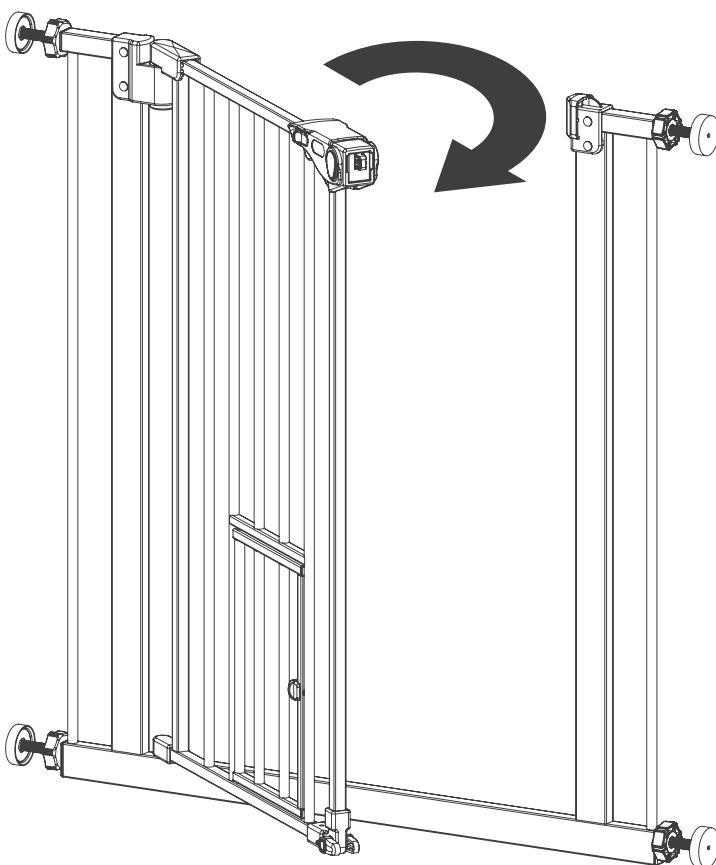
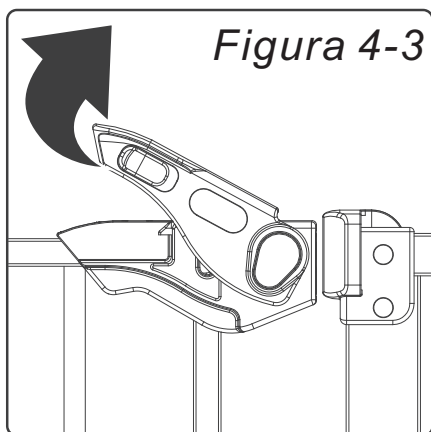
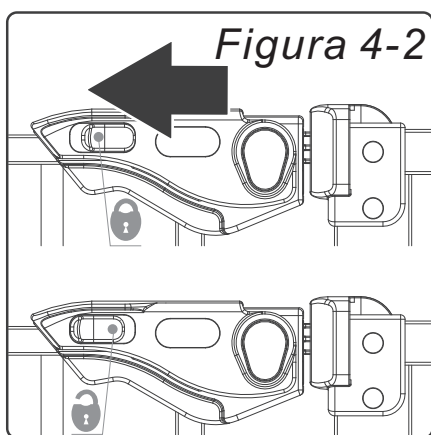
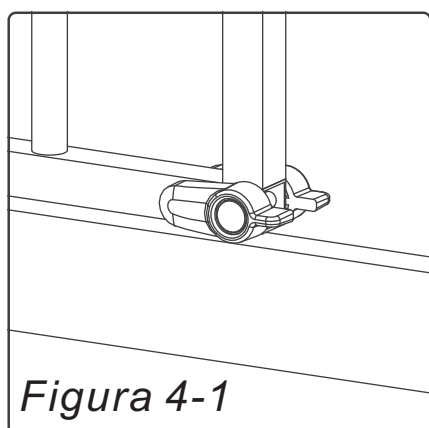

Cierre la puerta y asegúrese de que el pestillo de la puerta en la parte superior se cierre y luego coloque la cerradura en la parte inferior de la puerta hacia abajo en el lado ocupado por el niño. La puerta se abrirá en ambos sentidos a menos que uno de los topes de oscilación esté bajado. La puerta no se moverá en absoluto si ambos topes están bajados. (Figura 4-4)



Figura 4-4

Cuando la puerta está abierta, puede cerrarse automáticamente y bloquearse.

Cuando el ancho de acceso de la puerta es de 8 pulgadas (20 cm), la puerta puede cerrarse automáticamente (Figura 4-5).

NOTA Cuando el ancho de acceso de la puerta es mayor de 23 pulgadas (58 cm), la puerta estará abierta normalmente (Figura 4-6)

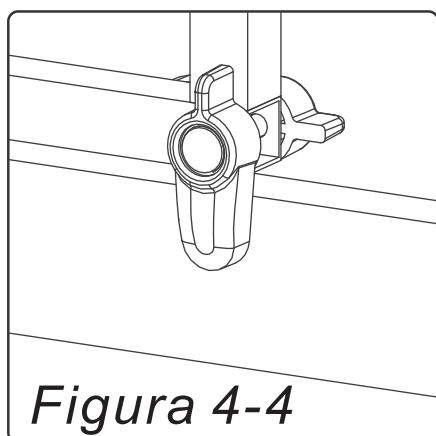

Figura 4-5



Figura 4-6

USO EN LA PARTE SUPERIOR DE LAS ESCALERAS

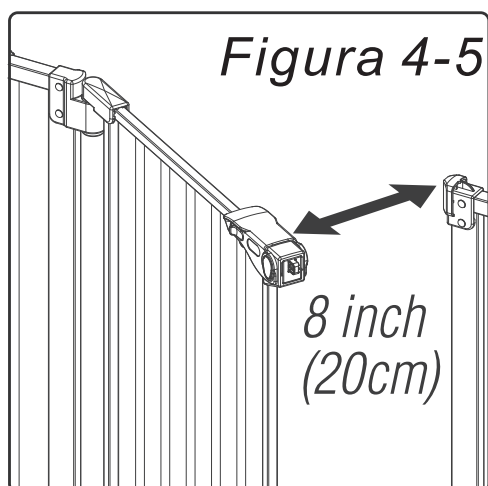
Si la puerta se usa en la parte superior de las escaleras, recomendamos que mantenga una distancia segura al primer escalón de al menos **16 pulgadas (40 cm)**. (Figura A)

El uso de las ventosas de pared fijará su puerta con más firmeza en la entrada o el acceso.

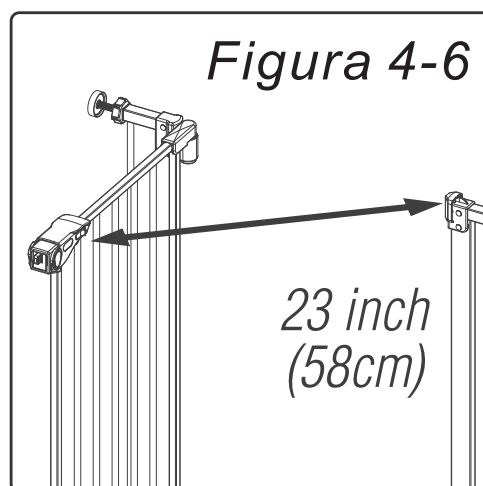
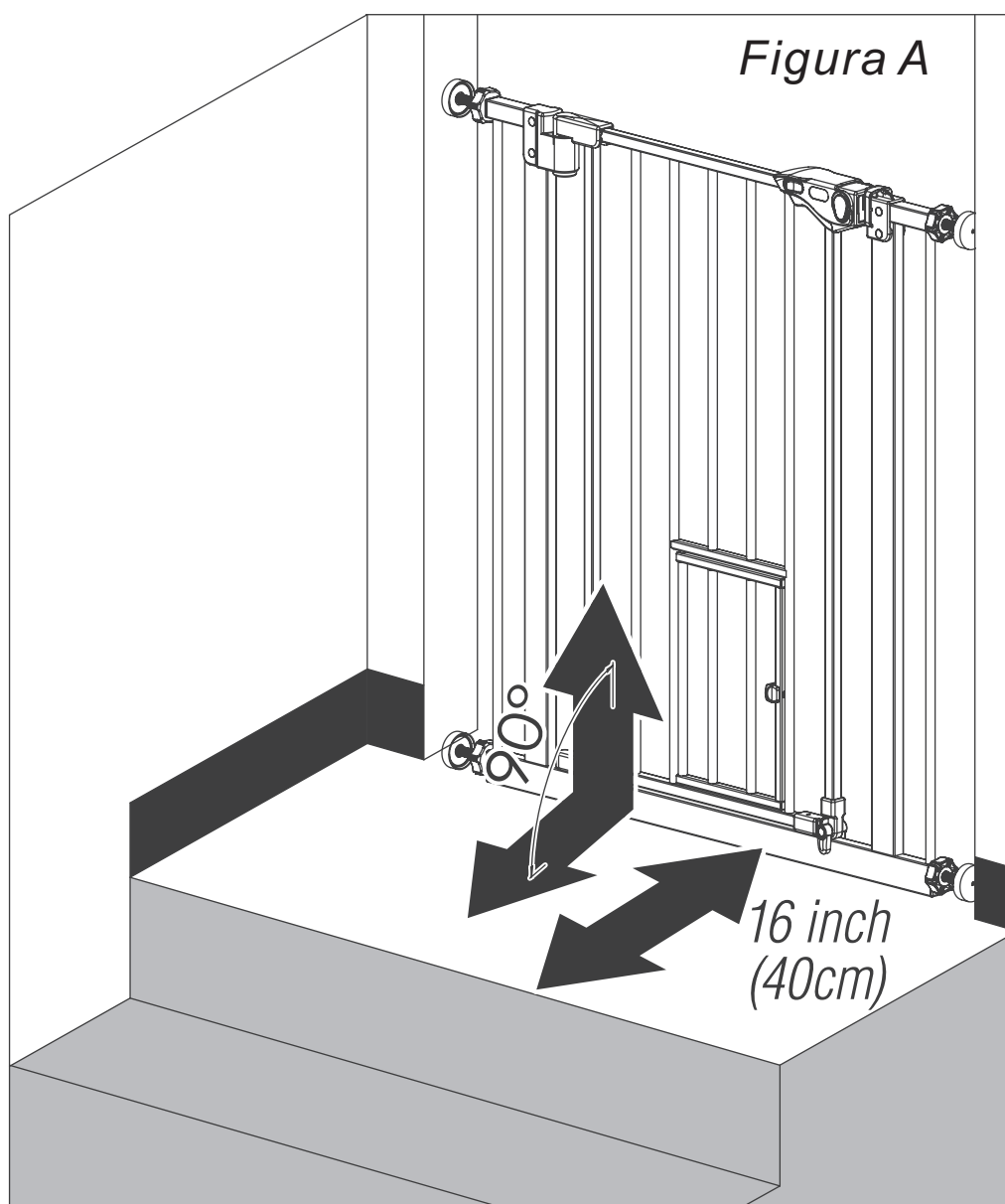

PARA ABRIR PUERTA PEQUEÑA PARA MASCOTAS

Tire del pasador de resorte hacia atrás para abrir la puerta pequeña para mascotas (*Figura 6-1 y 6-2*).

Figura 6-1



Figura 6-2



PARA REMOVER SU PUERTA DE LA PARED

Para remover la puerta de la pared, gire los volantes de ajuste en cada una de las (4) varillas roscadas para despresurizar la puerta de su entrada o acceso. Luego, tire de la puerta o empuje la puerta suavemente para liberarla de su entrada o acceso.

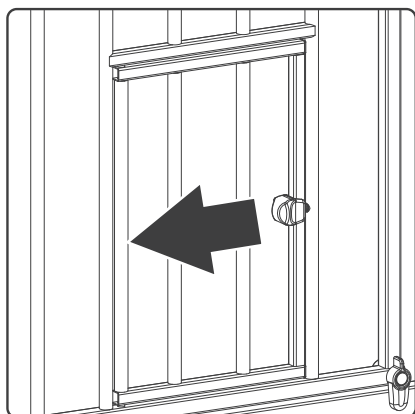
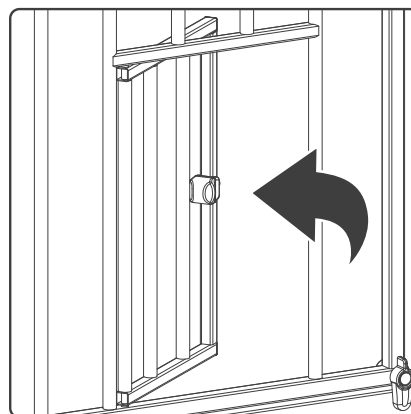
CUIDADO Y MANTENIMIENTO

Revise la puerta periódicamente para detectar los daños, desgastes o faltantes de componentes. No lo utilice si falta alguna pieza, está desgastada o dañada. Revise la puerta con regularidad para asegurarse de que todos los herrajes y montajes estén apretados. No utilice limpiadores abrasivos ni lejía para la limpieza. Limpiar el producto con esponjas con agua tibia y detergentes suaves.



WARNUNG

Eine unsachgemäße Verwendung kann zu Verletzungen führen

- Installieren und verwenden Sie das Tor **IMMER** wie vorgeschrieben und verwenden Sie alle erforderlichen Teile
- Sie **MÜSSEN** die Wandhalterungen anbringen, um das Tor an seinem Platz zu halten; ohne Wandhalterungen kann das Kind das Tor herauschieben und entkommen
- **STOPPEN** Sie die Benutzung, wenn ein Kind oder Haustier über das Tor klettern oder es verschieben kann
- **VERWENDEN** Sie das Tor nur, wenn der Verriegelungsmechanismus sicher eingerastet ist
- **NIEMALS** verwenden, um das Kind vom Pool fernzuhalten
- Lassen sie ihr Kind **NIEMALS** unbeaufsichtigt
- Zur Verwendung mit Kindern zwischen 6 und 24 Monaten vorgesehen
- Gemäß den Anweisungen des Herstellers montieren

MODELL NR.	Keine Verlängerung	10 cm Verlängerung	15 cm Verlängerung	MAX LÄNGE
D06-122BK	✓			74cm(29in)-79cm(31in)
D06-122WT	✓			74cm(29in)-79cm(31in)
D06-123	✓			74cm(29in)-79cm(31in)
D06-124	✓			74cm(29in)-79cm(31in)

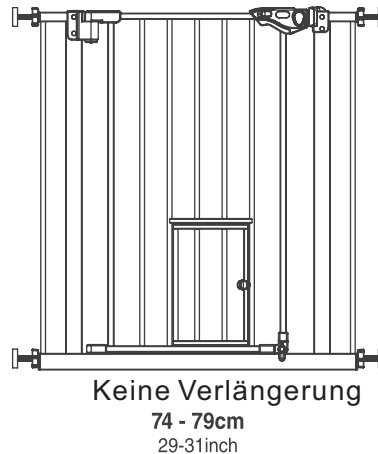

VOR DER BENUTZUNG DES PRODUKTS

WICHTIG

- Eine unsachgemäße Installation kann dazu führen, dass das Tor instabil wird oder sich von der Türöffnung löst.
- Auf beiden Seiten des Tores müssen immer die unteren Verriegelungen verwendet werden.
- Überprüfen Sie das Tor regelmäßig, um zu prüfen, ob alle Beschläge und Befestigungen fest angezogen sind.
- Verwenden Sie das Tor nicht, wenn Teile fehlen oder beschädigt sind.
- **STOPPEN** Sie die Benutzung, wenn ein Kind oder Haustier über das Tor klettern oder es verschieben kann.
- Zusätzliche Teile oder Ersatzteile sollten nur vom Hersteller oder Händler bezogen werden.

VOR DEM ZUSAMMENBAU

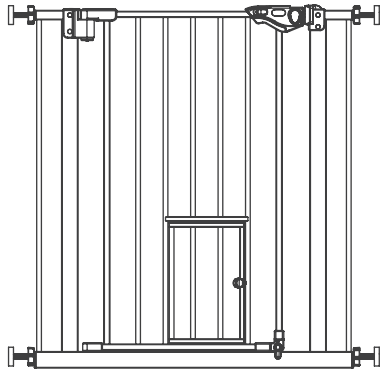

A: Torrahmen (1)

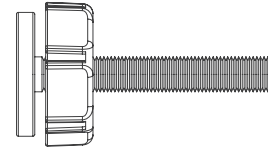

B: Gewindespindeln (4)

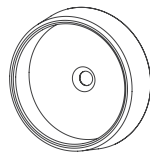

C: Wandhalter (4)

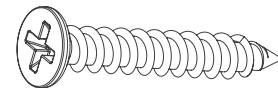

D: Schrauben (4)



E: Schraubenschlüssel (1)

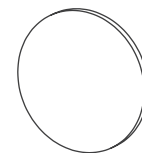

F: Aufkleber (4)

EINBAU DES TORES

SCHRITT 1

Finden Sie die (4) Gewindestangen (B). Drehen Sie die Einstellräder entlang des Gewindes, um den Spalt zwischen dem Einstellrad und dem Gummifuß zu beseitigen (*Abbildung 1-1*).

HINWEIS Möglicherweise bemerken Sie einen leichten Spalt zwischen der Türverriegelung des Tores und dem Rahmen (*Abbildung 1-2*).

DIES IST KEIN FEHLER, da es sich um ein druckmontiertes Tor handelt und dieser Spalt verschwindet, sobald Sie das Tor in seiner Öffnung festziehen.



Abbildung 1-1



Abbildung 1-2

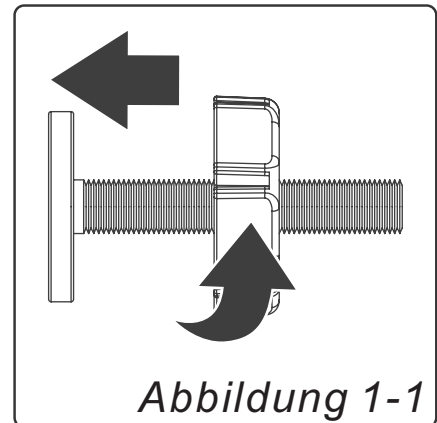

ENTFERNEN SIE DEN KABELBINDER ERST, WENN DIE INSTALLATION ABGESCHLOSSEN IST. (*Abbildung 1-3*)

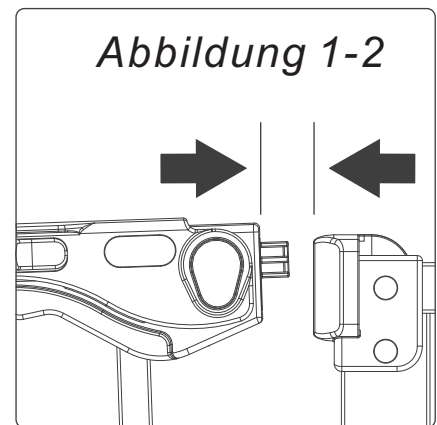
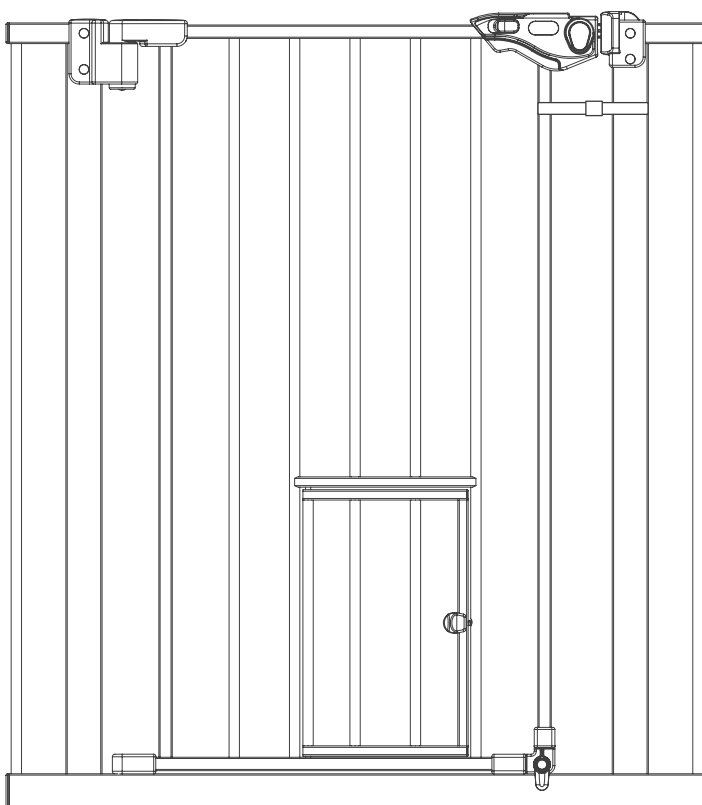

Abbildung 1-3

SCHRITT 2

Stecken Sie die Gewindestangen mit den Einstellrädern in die Bohrungen an allen vier Ecken der Seiten des Tores. (*Abbildung 2-1*)

1/8 Zoll Stellen Sie das Tor so in die gewünschte Öffnung, dass die Unterseite dicht am Boden liegt. Der Abstand zwischen der Unterseite des Tores und dem Boden sollte weniger als **0,3 cm (1/8 Zoll)** betragen (*Abbildung 2-2*). Wenn Sie mit der Positionierung des Tores zufrieden sind, zeichnen Sie die Wandhalter der Spindel auf die Oberfläche der Öffnung und stellen Sie sicher, dass diese eben sind (*Abbildung 2-3*). Entfernen Sie das Tor aus der Öffnung. Schrauben Sie dann die 4 Wandhalter mit den Schrauben an die Wand (*Abbildung 2-4*), oder kleben Sie die 4 Wandhalter mit den mitgelieferten Aufklebern an (*Abbildung 2-5*).

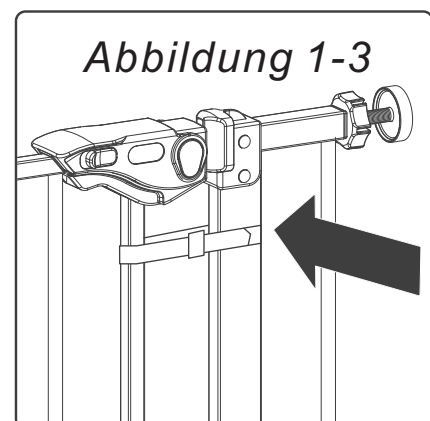
Abbildung 2-1



Abbildung 2-2



Abbildung 2-3

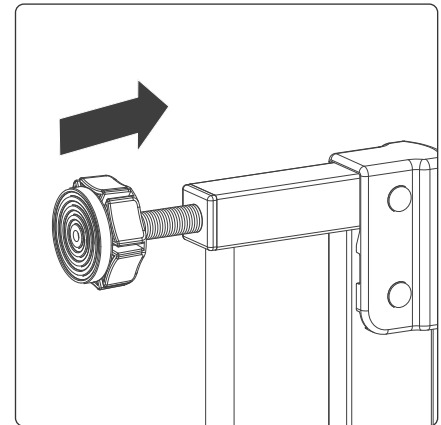

Abbildung 2-4

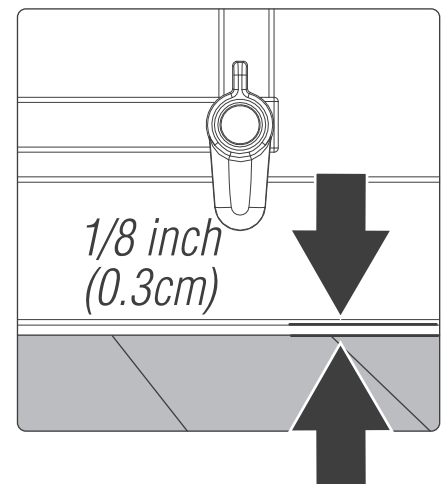

Abbildung 2-5

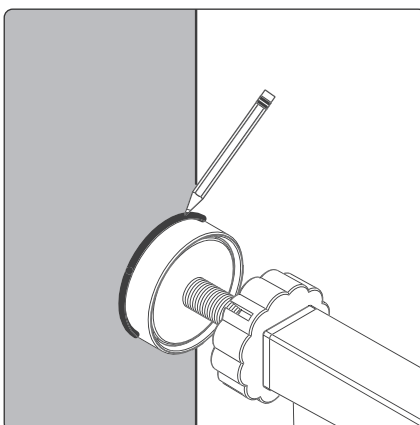

EINBAU DES TORES

SCHRITT 3 Setzen Sie alle 4 Gewindestangen in die Wandhalter ein (*Abbildung 3-1*). Ziehen Sie die Räder mit dem Schraubenschlüssel fest. (*Abbildung 3-2 und Abbildung 3-3*) Ziehen Sie sie nicht zu fest an. Möglicherweise müssen Sie die Gewindestangen festhalten, während Sie die Einstellräder drehen, um sicherzustellen, dass sich die gesamte Einheit beim Einbau des Tores nicht dreht. Schraubenschlüssel

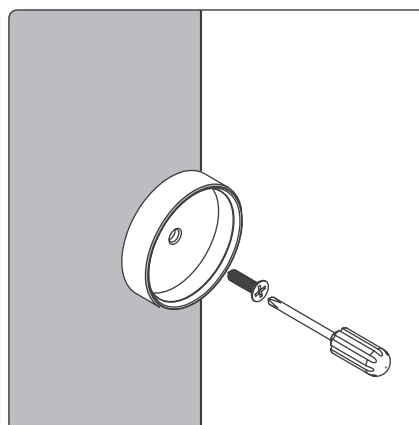
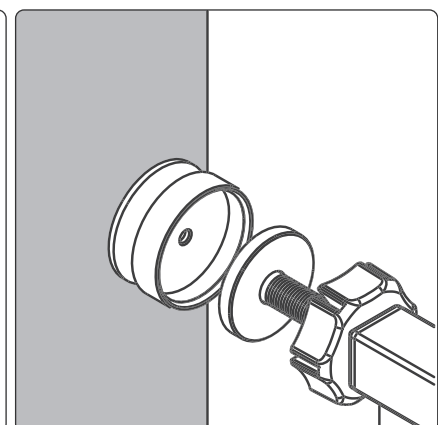
HINWEIS Wenn Ihr Torschloss nicht richtig in die Aufnahmekomponente einrastet, stellen Sie sicher, dass Ihr Tor eben und richtig montiert ist und dass Sie die Einstellräder nicht zu fest angezogen haben.

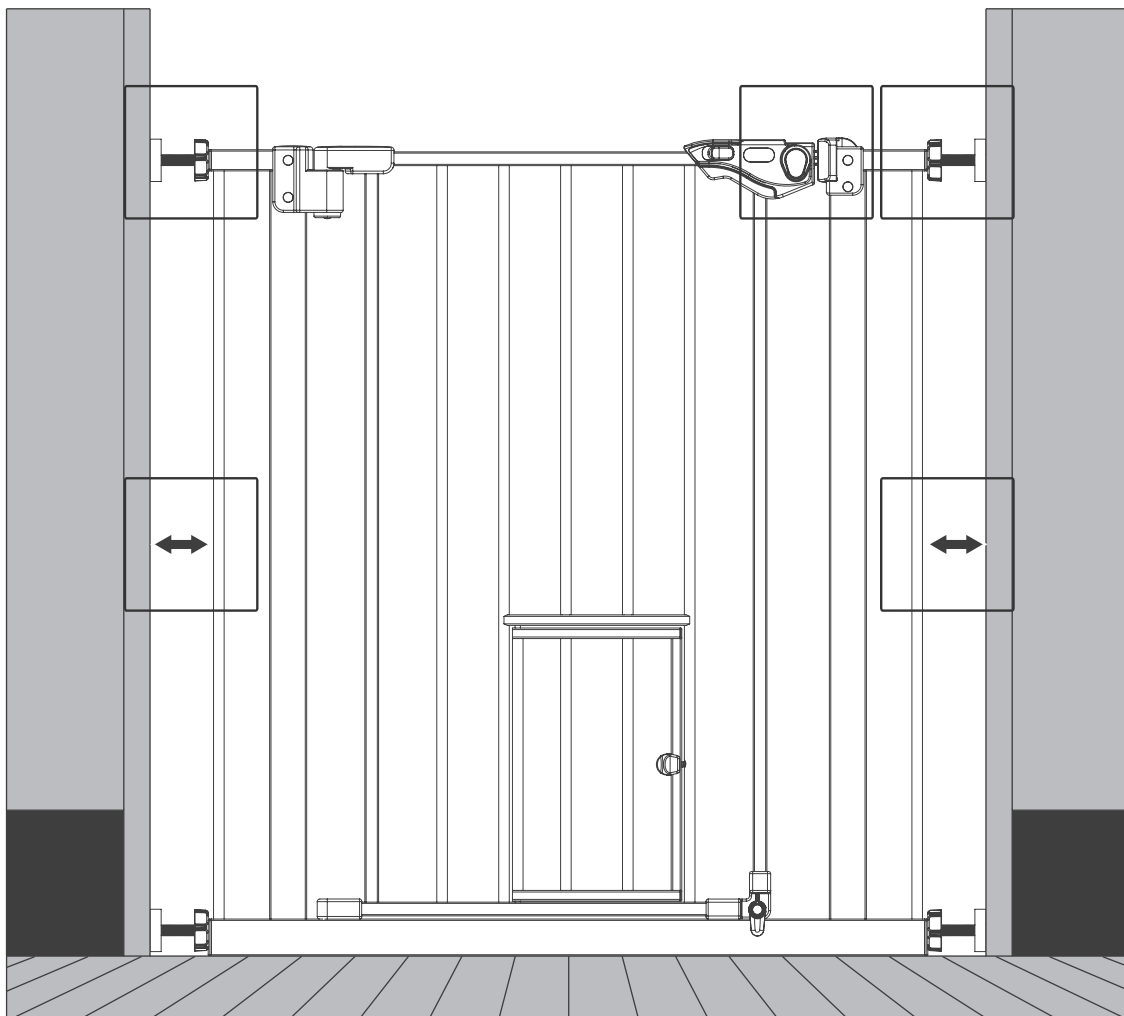

HINWEIS Der Spalt zwischen dem Tor und der Wand sollte auf beiden Seiten nicht mehr als **6,3 cm (2,5 Zoll)** betragen (Abbildung 3-4 und 3-5).

Wenn das Tor ordnungsgemäß installiert wurde, sollte der Spalt zwischen dem Türschloss und dem Rahmen nun geschlossen sein (Abbildung 3-6).

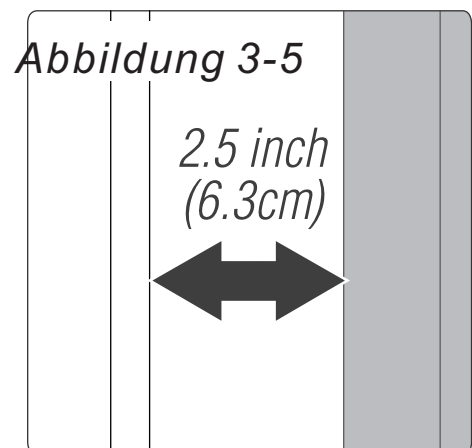
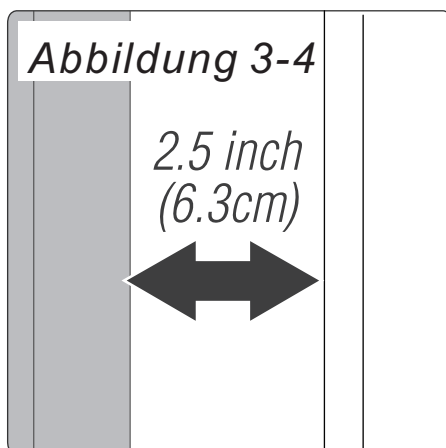
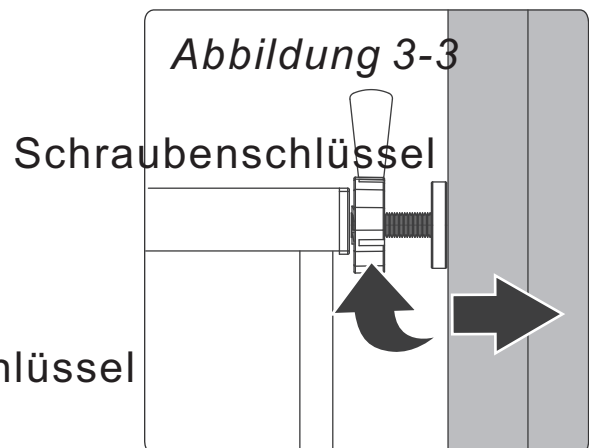
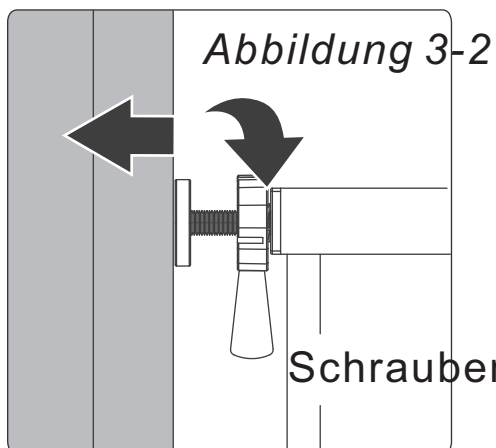
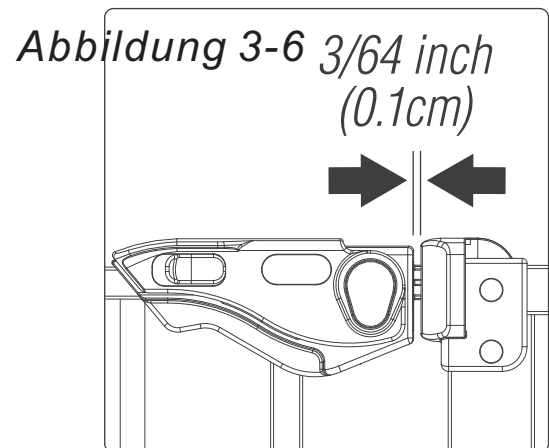
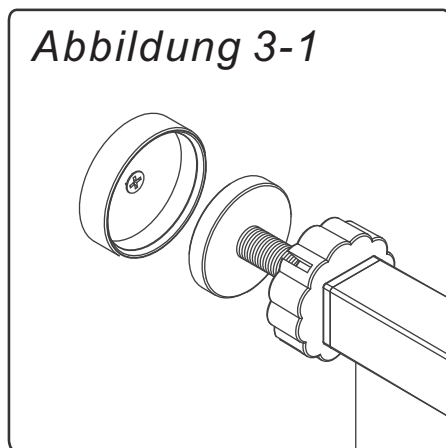

BEDIENUNG DER

TÜRVERRIEGELUNG

Öffnen - Vergewissern Sie sich, dass sich die unteren Verriegelungen an der Unterseite des Tors in der horizontalen Position befinden (*Abbildung 4-1*). Ziehen Sie das Federschloss von der Easy-Open-Verriegelung weg und heben Sie gleichzeitig den Verriegelungshebel nach oben (*Abbildung 4-2 und 4-3*). Dadurch wird die Verriegelungsklinke vom Torrahmen gelöst und das Tor kann aufgeschoben oder aufgezo-gen werden.

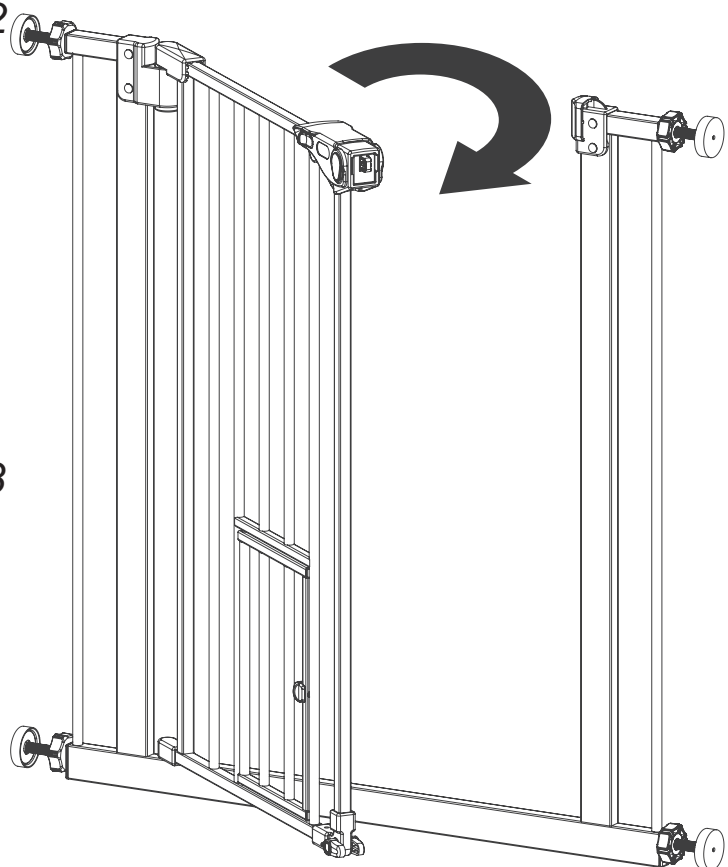
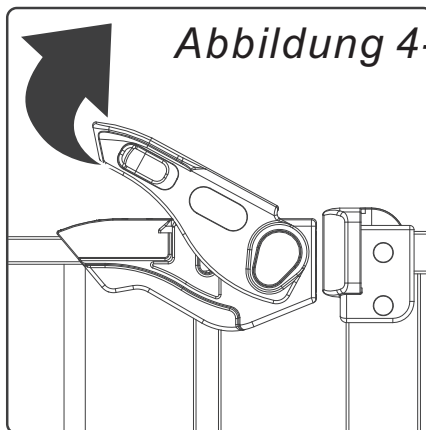
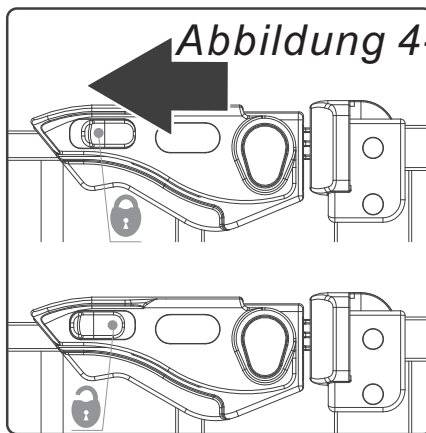
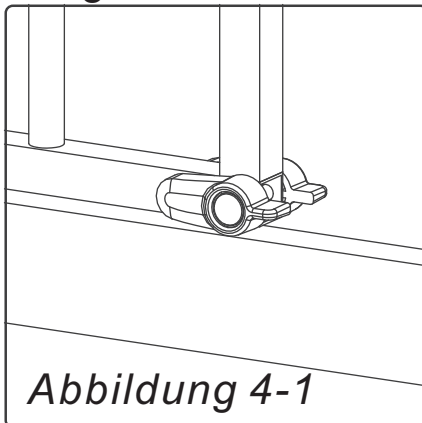

Schließen - Ziehen Sie das Tor zu und vergewissern Sie sich, dass die Türverriegelung oben geschlossen ist, und stellen Sie dann die Verriegelung unten am Tor auf der Seite ein, auf der sich das Kind befindet. Das Tor schwingt in beide Richtungen, es sei denn, einer der Schwenkanschläge ist heruntergelassen. Das Tor schwingt nicht, wenn beide Anschläge heruntergelassen sind (*Abbildung 4-4*)



Abbildung 4-4

Sobald das Tor geöffnet ist, kann es sich automatisch schließen und verriegeln.

Wenn die Öffnungsbreite des Tores **20 cm (8 Zoll)** beträgt, hat das Tor die Funktion des automatischen Schließens (*Abbildung 4-5*).

HINWEIS Wenn die Öffnungsbreite des Tores mehr als **58 cm (23 Zoll)** beträgt, ist das Tor offen (*Abbildung 4-6*).

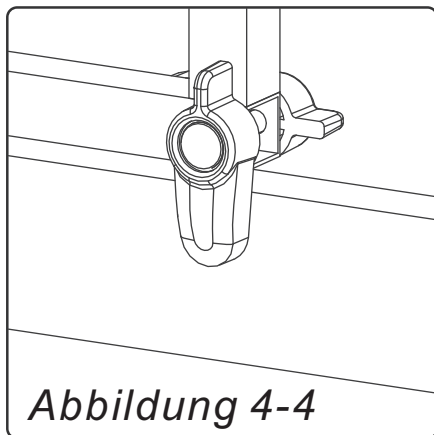
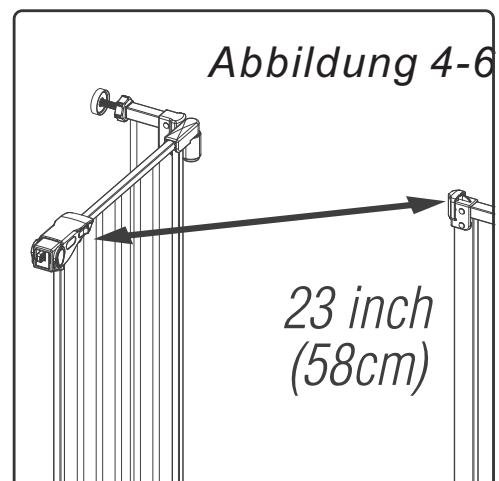
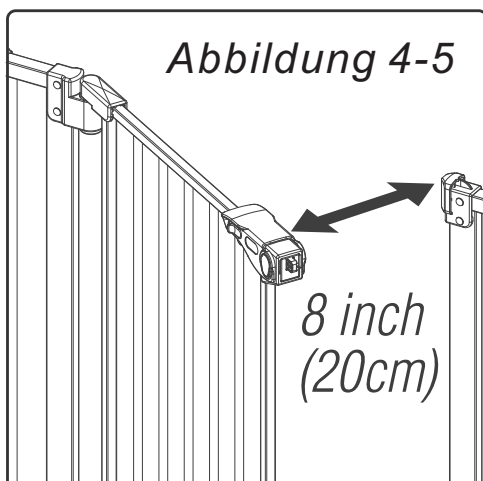

VERWENDUNG AM OBEREN ENDE DER TREPPE

Wenn das Tor am oberen Ende einer Treppe verwendet wird, empfehlen wir einen Sicherheitsabstand von mindestens **40 cm (16 Zoll)** zur ersten Stufe. (*Abbildung A*)

Wenn Sie die Wandhalter verwenden, wird Ihr Tor fester in der Tür oder Öffnung befestigt.

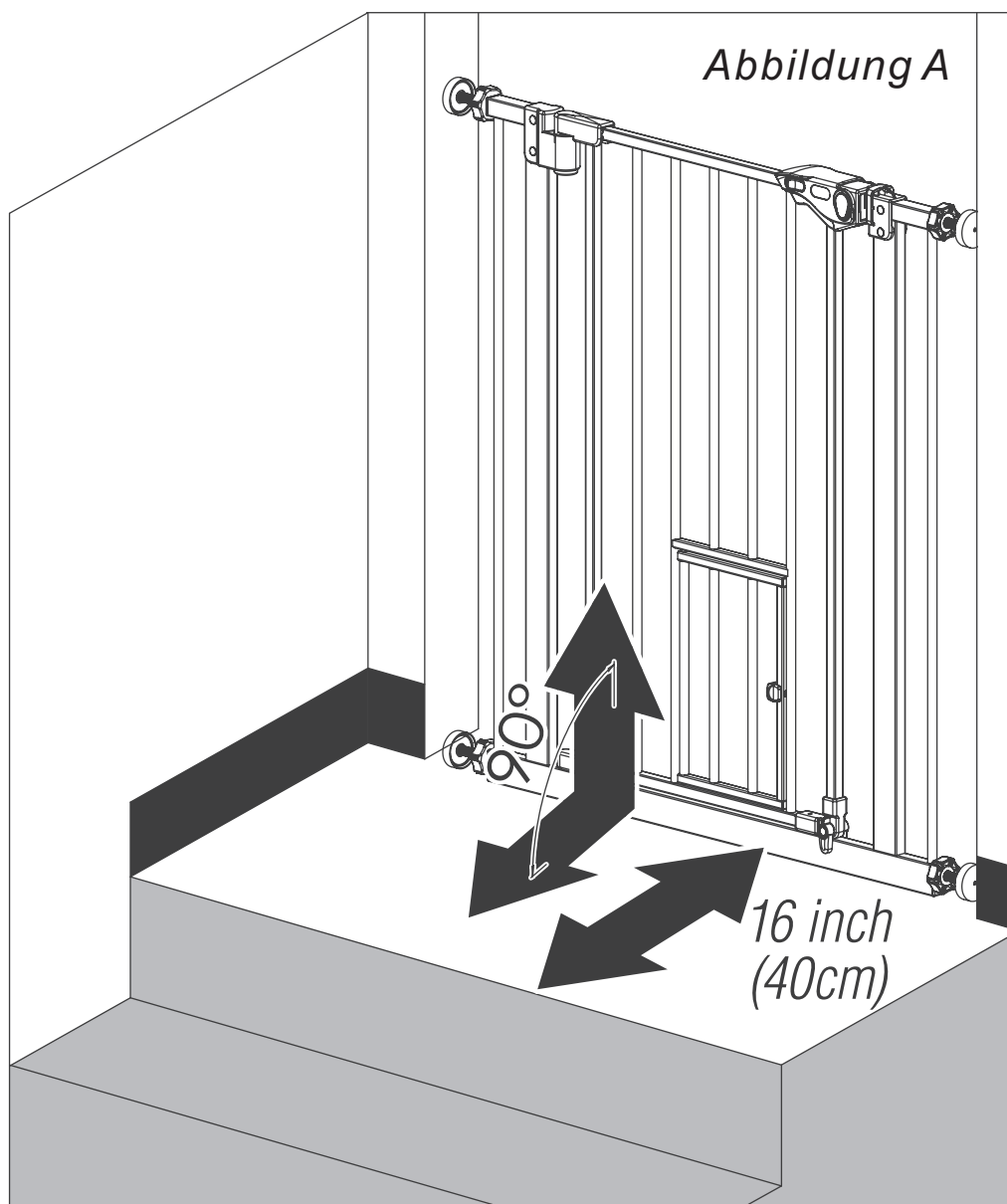

ÖFFNEN DER KLEINEN HAUSTIERTÜR

Um die kleine Haustiertür zu benutzen, ziehen Sie den Federstift zurück (Abbildung 6-1 und 6-2).

Abbildung 6-1



Abbildung 6-2



ENTFERNEN DES TORES VON DER WAND

Um das Tor aus der Wand zu entfernen, drehen Sie die Einstellräder an jeder der (4) Gewindespindeln, um den Druck aus der Tür oder Öffnung zu nehmen. Ziehen oder schieben Sie das Tor dann vorsichtig aus der Tür oder der Öffnung heraus.

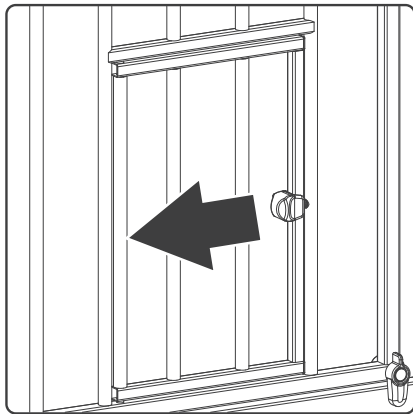
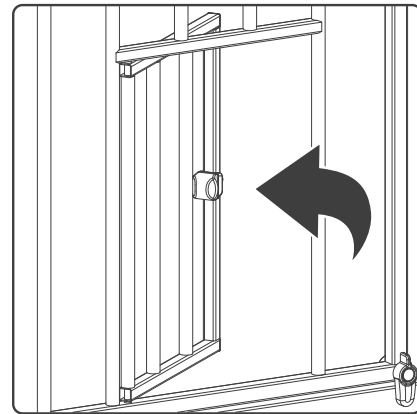
PFLEGE UND WARTUNG

Überprüfen Sie das Tor regelmäßig auf Anzeichen von Beschädigung, Verschleiß oder fehlenden Teilen. Verwenden Sie das Tor nicht, wenn ein Teil fehlt, abgenutzt oder beschädigt ist. Überprüfen Sie das Tor regelmäßig, um sicherzustellen, dass alle Beschläge und Befestigungen fest angezogen sind. Verwenden Sie keine Scheuermittel oder Bleichmittel. Reinigen Sie das Tor mit einem Schwamm, warmem Wasser und einem milden Reinigungsmittel.



AVVERTENZA

I bambini potrebbero essere morti o gravemente feriti quando il cancelletto non sono stati installati in modo sicuro.

Installare e utilizzare **SEMPRE** il cancelletto come indicato utilizzando tutte le parti necessarie.

È necessario installare i scodellini a muro per mantenere il cancelletto in posizione. Senza i scodellini a muro, il bambino può spingersi fuori e scappare.

INTERROMPERE l'uso quando un bambino può scavalcare o sbloccare il cancelletto.

UTILIZZARE solo con il meccanismo di blocco saldamente inserito.

NON usarlo **MAI** per tenere il bambino lontano dalla piscina.

NON lasciare **MAI** il bambino incustodito.

Destinato all'uso per bambini fra i 6 e i 24 mesi.

Installare secondo le istruzioni del produttore.

MODELLO	Senza Estensione	Estensione da 10 cm	Estensione da 15 cm	Dimensioni Massime
D06-122BK	✓			74cm(29in)-79cm(31in)
D06-122WT	✓			74cm(29in)-79cm(31in)
D06-123	✓			74cm(29in)-79cm(31in)
D06-124	✓			74cm(29in)-79cm(31in)

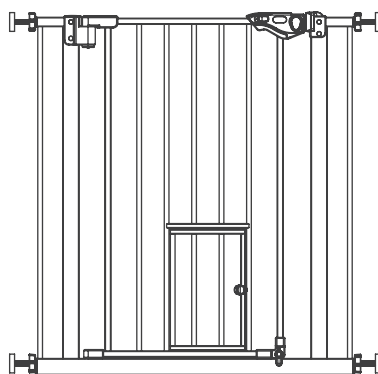

Senza Estensione

74 - 79cm
29-31inch

PRIMA DI UTILIZZARE IL PRODOTTO

IMPORTANTE

Un'installazione errata potrebbe causare l'instabilità del cancelletto o il distacco dalla porta.

Le serrature alla base devono essere sempre utilizzate, su entrambi i lati del cancelletto.

Questo prodotto non previene necessariamente tutti gli incidenti.

Controllare regolarmente il cancelletto per vedere se tutti i hardware e i componenti di fissaggio sono serrati.

Non utilizzare se alcuni componenti sono mancanti o danneggiati.

INTERROMPERE l'uso quando un animale domestico può scavalcare o distaccare il cancelletto.

Le parti aggiuntive o di ricambio devono essere ottenute solo dal produttore o dal distributore.

PRIMA DI ASSEMBLAGGIO

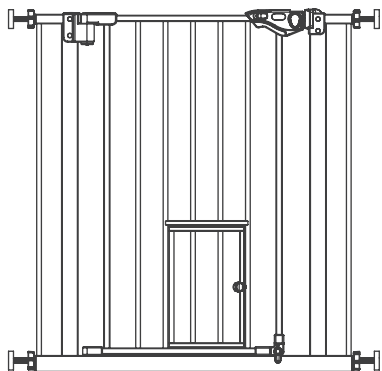

A: Telaio del cancelletto (1)

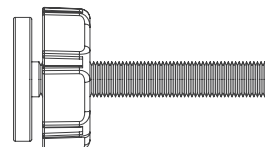

B: Volantino per regolazione(4)

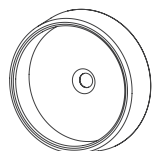

C: Scodellino a muro (4)

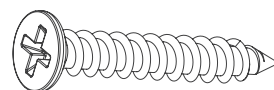

D: Viti (4)



E: Chiave (1)

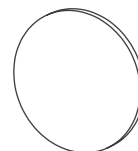

F: Strisce adesivo (4)

INSTALLAZIONE DEL VOSTRO CANCELLETTO

PASSO 1

Posizionare (4) Volantino per regolazione (B). Ruotare il volantino lungo la filettatura, eliminando lo spazio tra il volantino per regolazione e il piedino in gomma (*Figura 1-1*).

NOTA: Si può notare un piccolo spazio tra il chiavistello del cancelletto e il telaio (*Figura 1-2*).

QUESTO NON È UN DIFETTO. Questo cancelletto è un cancelletto montato a pressione e questo spazio scomparirà una volta serrato il cancelletto nella sua apertura.



Figura 1-1



Figura 1-2

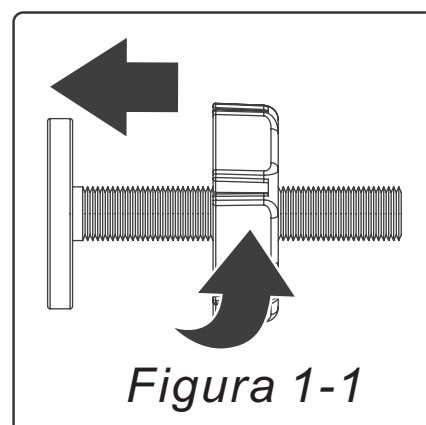

NON RIMUOVERE LA FASCETTA FINO A QUANDO L'INSTALLAZIONE NON È COMPLETATA. (*Figura 1-3*)

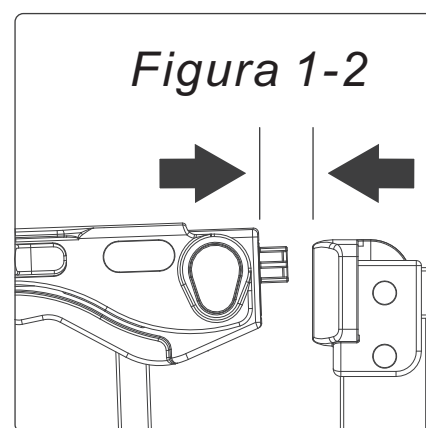
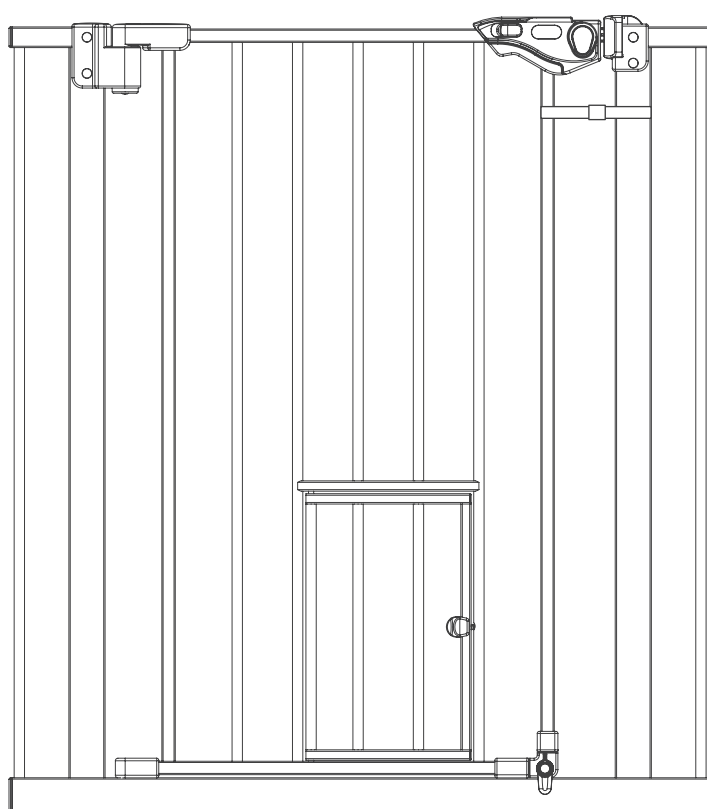

Figura 1-3

PASSO 2

Inserire l'asta filettata del Volantino per regolazione nel foro ruotando il volantino. Fare così su tutti e quattro gli angoli dei lati del cancelletto. (Figura 2-1)

Posizionare il cancelletto nell'apertura desiderata con il fondo vicino al pavimento. La distanza tra la parte inferiore del cancelletto e il pavimento deve essere inferiore a 0,3 cm (1/8 di pollice) (Figura 2-2). Una volta che sei soddisfatto del posizionamento del tuo cancelletto, regolare i piedini in gomma con aste sulla superficie dell'apertura assicurando che siano allo stesso livello (Figura 2-3). E poi rimuovere il cancelletto dall'apertura. Avvitare i 4 scodellini a muro alla parete utilizzando le viti (Figura 2-4) oppure incollare i 4 scodellini utilizzando le strisce adesive fornite (Figura 2-5).

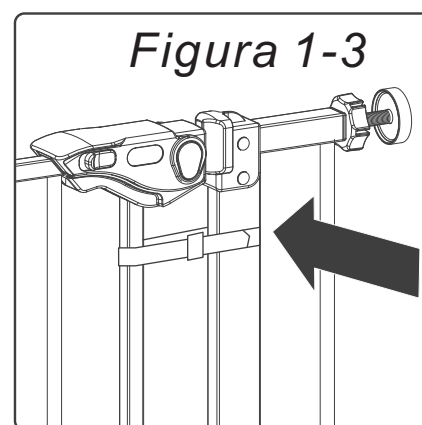
Figura 2-1



Figura 2-2



Figura 2-3

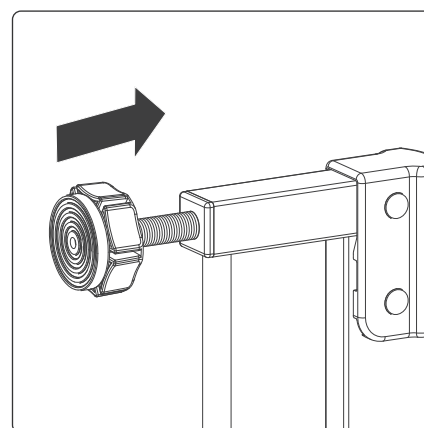

Figura 2-4

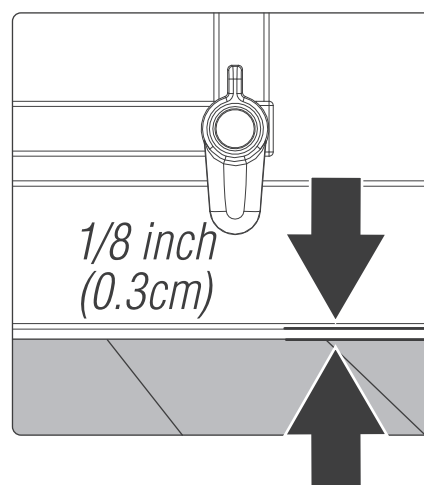

Figura 2-5

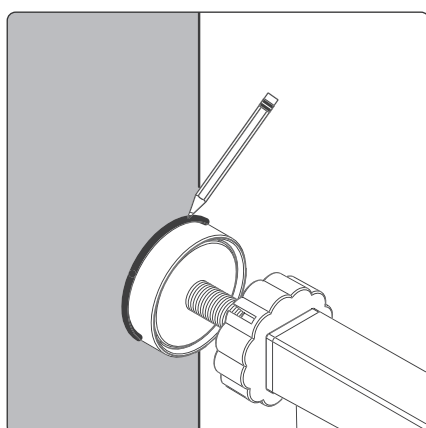

INSTALLAZIONE DEL VOSTRO CANCELLETTO

PASSO 3

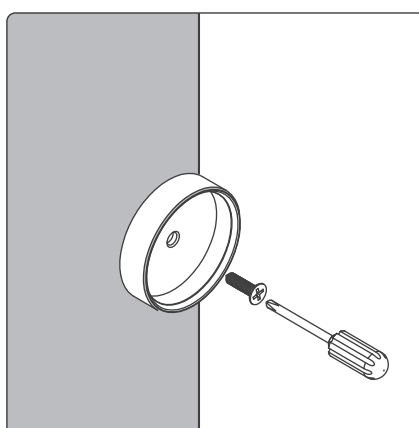
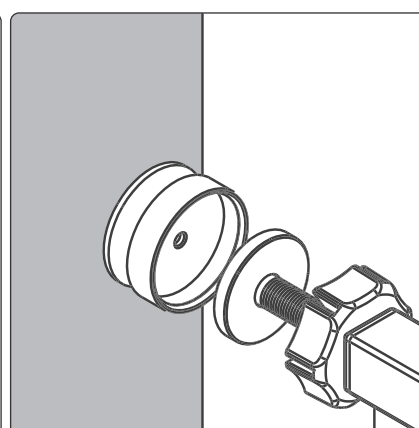
Inserire tutte e 4 le aste filettate dei volantini nei scodellini a parete (*Figura 3-1*). Stringere i volantini con la chiave. (*Figura 3-2 e Figura 3-3*) Non serrare eccessivamente. Potrebbe essere necessario trattenere le aste filettate mentre si ruotano il volantino di regolazione per garantire che l'intera unità non ruota durante l'installazione del cancelletto.

NOTA: se il chiavistello della porta non si aggancia correttamente al componente ricevente, assicurarsi che il cancelletto sia in posizione orizzontale, montato correttamente e di non siano serrati eccessivamente i volantini di regolazione.

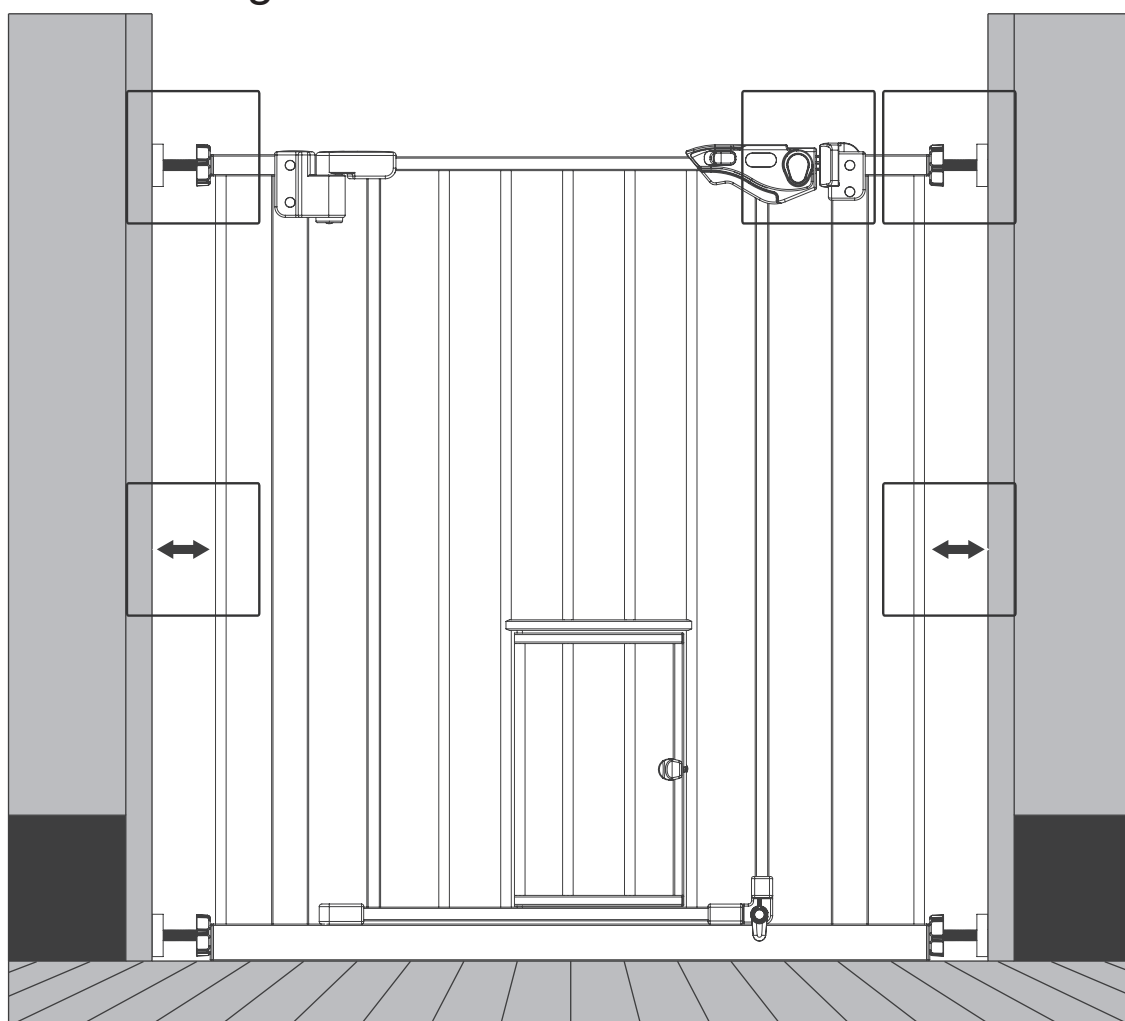

NOTA: Lo spazio tra il cancelletto e il muro non deve superare più di 2,5 pollici (6,3 cm) su entrambi i lati (*Figure 3-4 e 3-5*)

Se il cancelletto è stato installato correttamente, lo spazio tra il chiavistello della porta e il telaio dovrebbe ora essere chiuso (*Figure 3-6*)

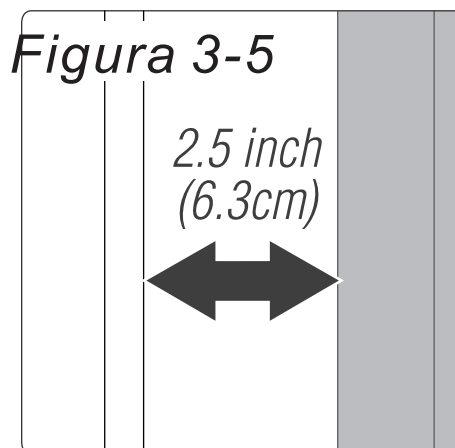
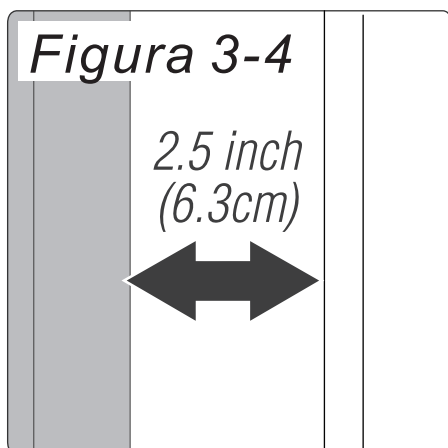
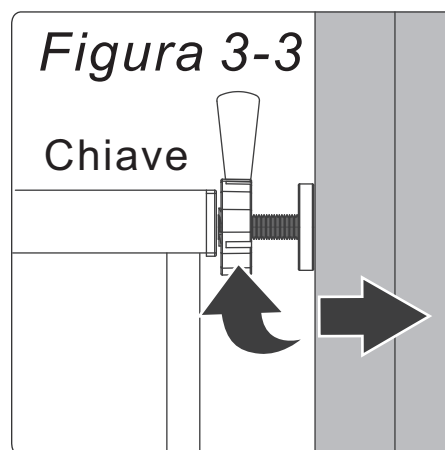
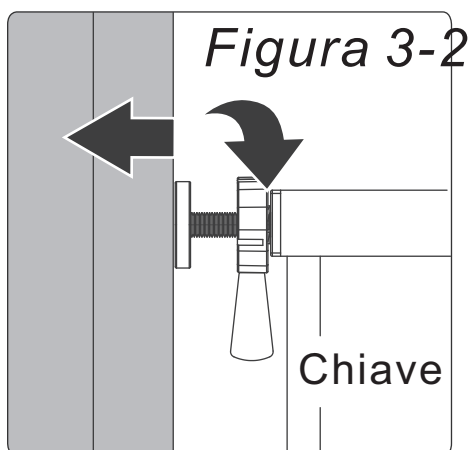
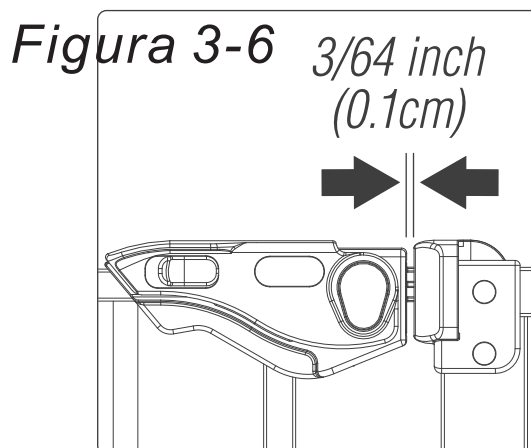
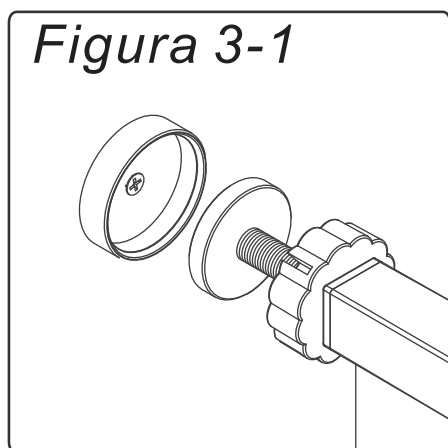

OPERAZIONE DEL CHIAVISTELLO DELLA PORTA

Per aprire - Assicurarsi che le serrature della base nella parte inferiore della porta del cancelletto siano in posizione orizzontale (*Figura 4-1*). Estrarre il blocco a molla dal chiavistello facile da aprire sollevando contemporaneamente la leva di blocco verso l'alto (*Figura 4-2 e 4-3*). Questo rilascerà il chiavistello dal telaio del cancelletto e consentirà alla porta di spingersi o aprirsi.

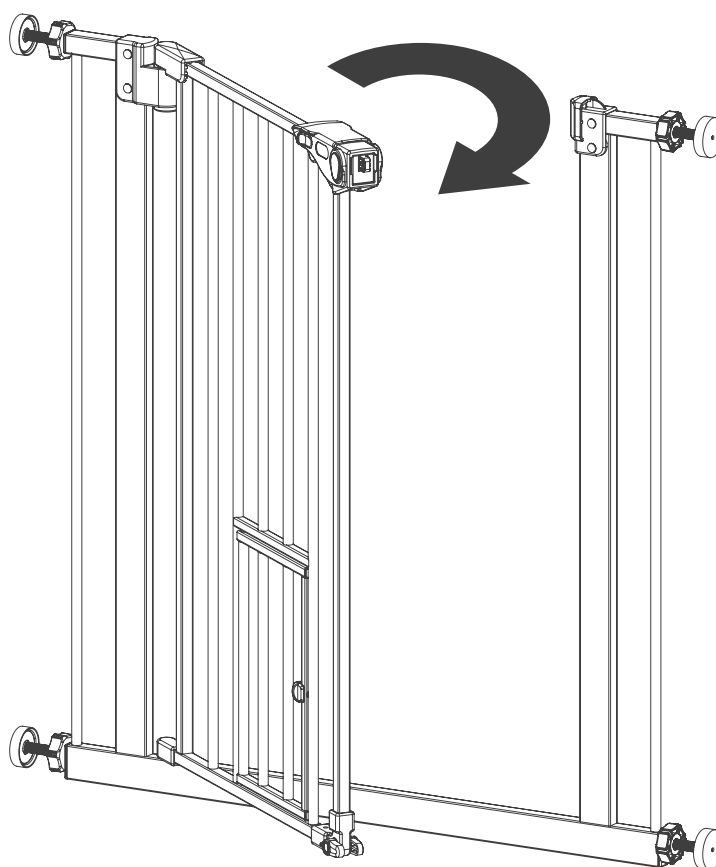
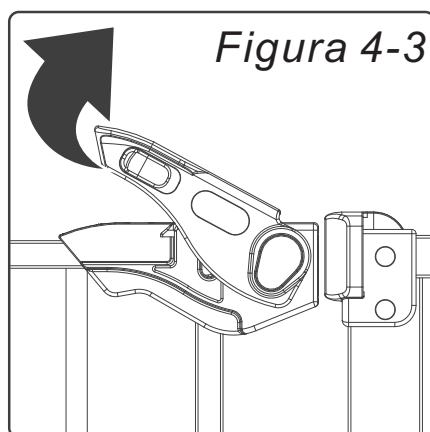
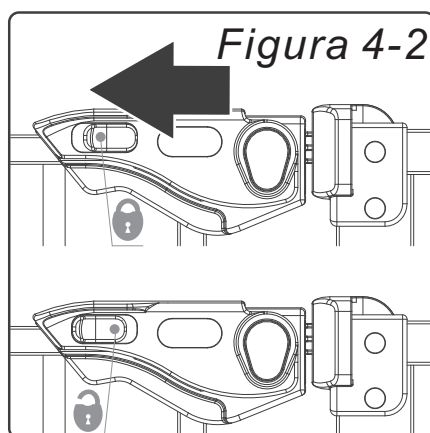
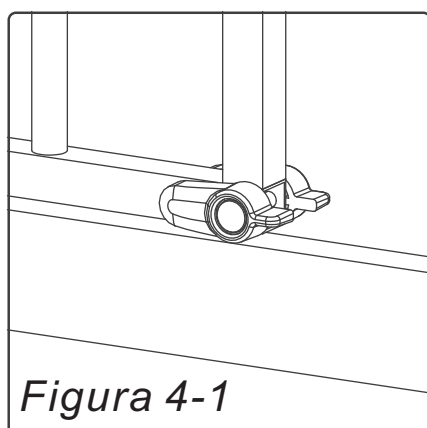

Per chiudere - Chiudere la porta e assicurarsi che il chiavistello della porta in alto si chiuda e e poi posizionare la serratura nella parte inferiore del cancelletto verso il basso sul lato occupato dal bambino, il cancelletto oscillerà in entrambe le direzioni a meno che uno delle serrature di rotazione non sia abbassato. Il cancelletto non oscillerà affatto se entrambi le serrature di rotazione sono abbassati. (Figura 4-4)

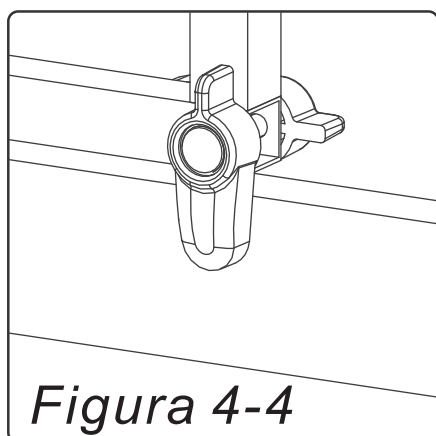

Una volta aperto, il cancelletto può chiudersi automaticamente e bloccarsi.

Quando la larghezza di apertura del cancelletto è di 8 pollici (20 cm), il cancelletto ha la funzione di chiusura automatica (Figura 4-5).

NOTA: Quando la larghezza di apertura del cancelletto è più di 23 pollici (58 cm), il cancelletto sarà normalmente aperto. (Figura 4-6)

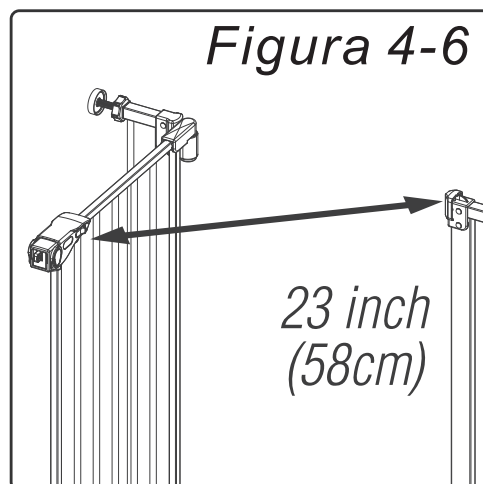
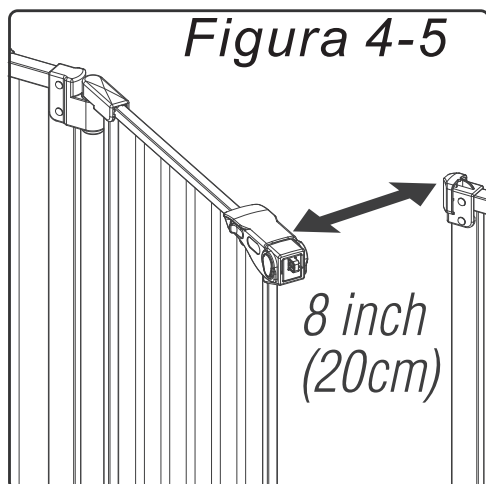

UTILIZZO IN CIMA ALLE SCALE

Se il cancelletto viene utilizzato in cima alle scale, raccomandiamo che la distanza di sicurezza dal primo gradino sia di almeno **16 pollici (40 cm)**.
(Figura A)

L'uso dei scodellini a muro fisserà il cancelletto più saldamente nell'ingresso o nell'apertura.

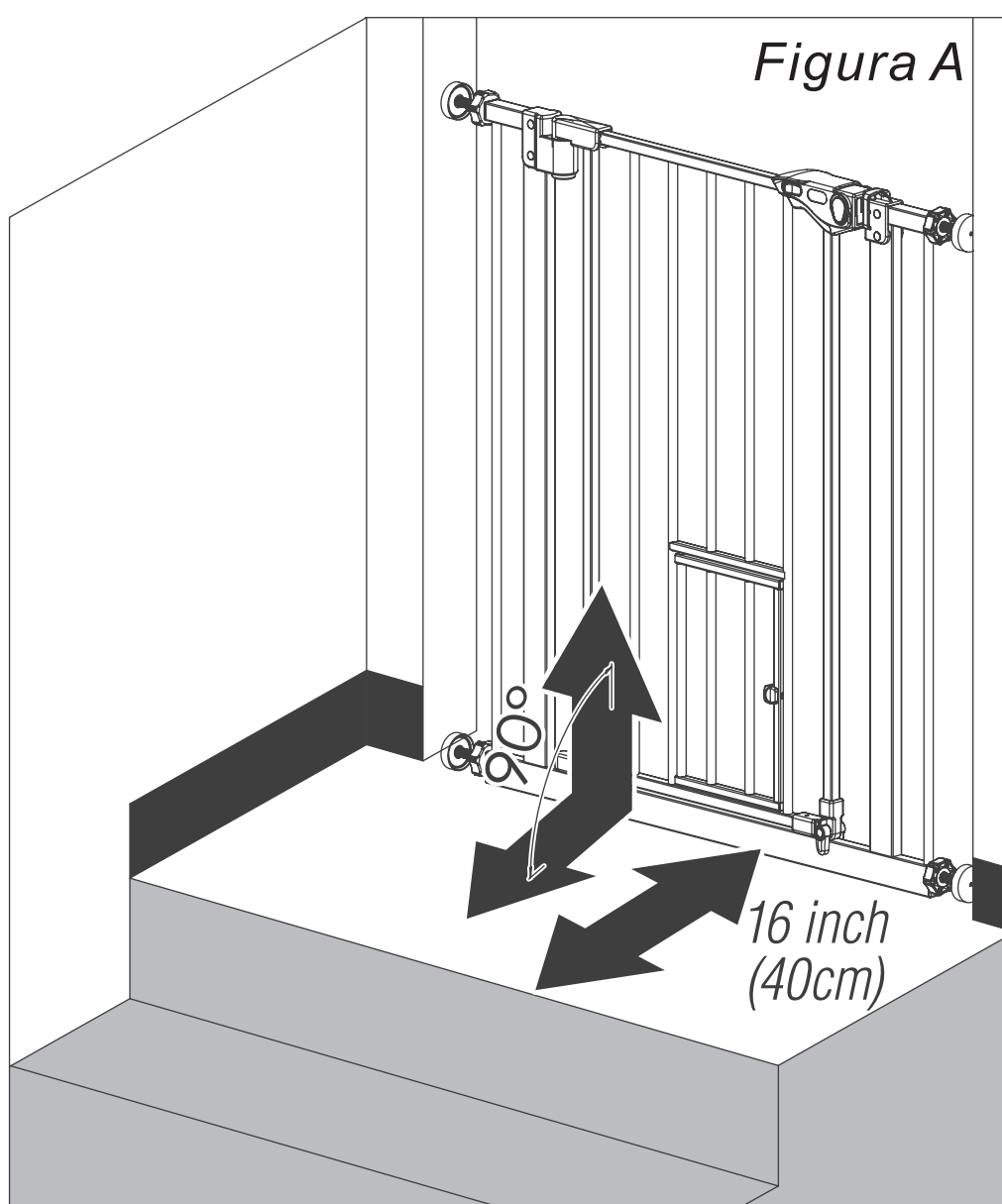

APERTURA DELLA PORTA PICCOLA PER ANIMALI DOMESTICI

Per utilizzare la porta piccola per animali domestici, tirare indietro il perno a molla (*Figura 6-1 e 6-2*).

Figura 6-1



Figura 6-2

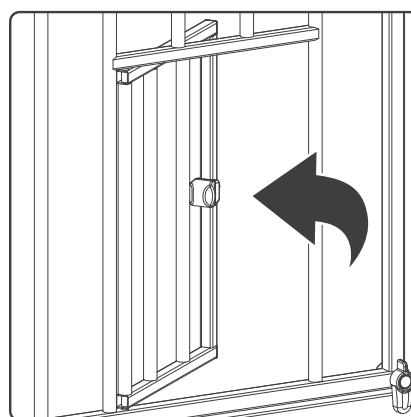

RIMOZIONE DEL CANCELLETTO DAL MURO

Per rimuovere il cancelletto dal muro, ruotare i volantini di regolazione su ciascuna delle (4) aste filettate per depressurizzare il cancelletto dall'ingresso o dall'apertura. E poi tirare o spingere delicatamente il cancelletto per liberarlo dall'ingresso o dall'apertura.

CURA E MANUTENZIONE

Controllare regolarmente il cancelletto per segni di danni, usura o componenti mancanti. Non utilizzare se una parte è mancante, usurata o danneggiata. Controllare regolarmente il cancelletto per assicurarsi che tutta il hardware e i componenti di fissaggio siano serrati. Non utilizzare detergenti abrasivi o candeggina. Pulire con una spugna con acqua tiepida e un detergente delicato.