

### Agility Jump Ring Installation

1. Turn the pegs into the lateral hurdle rods and remove subsequent end the cap.

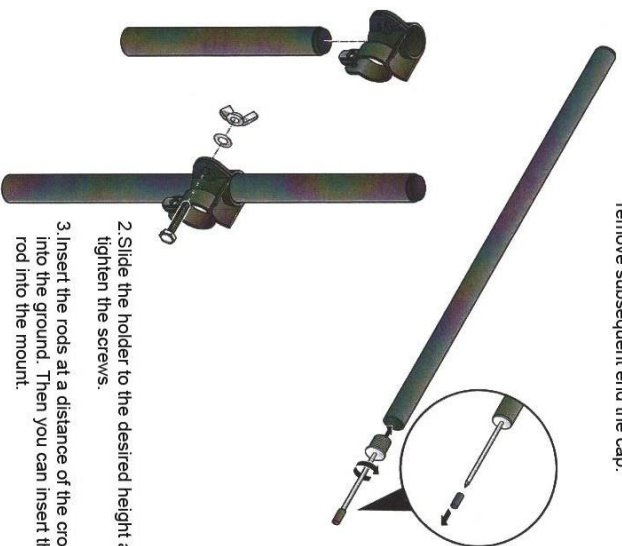

- Instructions**
1. Place the crossbar at a height of about 10 cm above the ground. Then jump together with your dog on the rod. Slowly increase the height.
  2. If the dog has lost its shyness, you can lure him with a treat to jump over the barrier. Please use the order like hurdle.
  3. As the next step, you stand in front of the hurdle with your dog, send him with chosen order for him to run over the hurdle and run along the side with him.
  4. Attach the jump ring and start again with Step 2. The dog successfully completes those tasks, go to step 3.

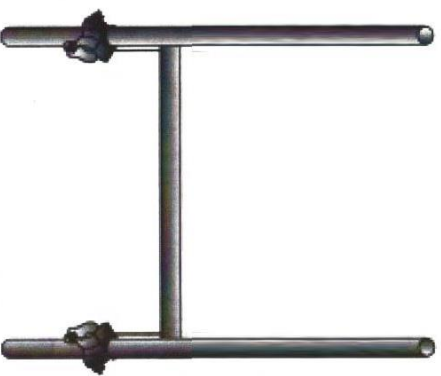

2. Slide the holder to the desired height and tighten the screws.
3. Insert the rods at a distance of the crossbar into the ground. Then you can insert the cross rod into the mount.
4. Fasten the jump ring using the Velcro strips between the bars.

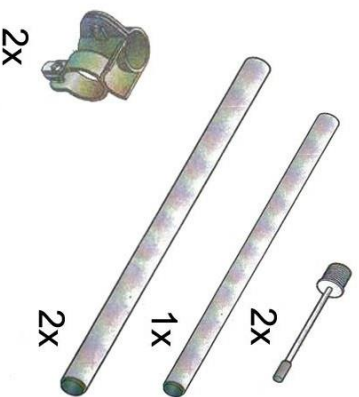

### Agility Slalom

**Picture 1:**  
In the first step, you should build an alley, in which the dog can go through without contact. At the beginning, you can direct the dog with a leash through the alley. Then you can motivate the dog with a ball and you can run by changing left and right side of the alley. Gradually you should send the dog to the alley at different angles. Once the dog runs into the alley, you can confirm with the order "Slalom".

**Picture 2:**  
If everything runs smoothly, get started now gradually continuing to push away the rows from each other until the dog touches the rods as it passes through.

**Picture 3:**  
When this works, you can plug in a straight slalom.

**ATTENTION!**  
It is very important that you not over train your dog. Particularly the puppies and young dogs have only very short concentration time.

If your dog has a problem with the steps, you might have proceed to fast. You should go back with the steps until the dog has mater this step.

Attention that the training should always end with a positive experience.

**Building**  
1. Turn the pegs in the slalom poles and pull off the protective cap.  
2. Use the guide to align the poles in a line. The colorful threads on the string indicate the distance before (wmm level is 60 cm)

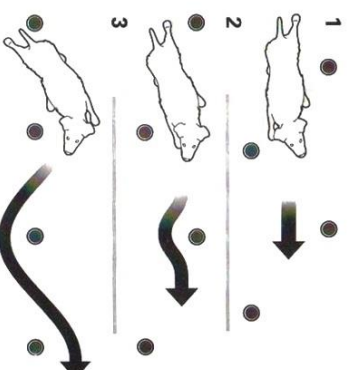

### Aufbau

1. Drehen Sie die Erdnägeln in die Slalomstangen und ziehen sie die Schutzkappe ab.

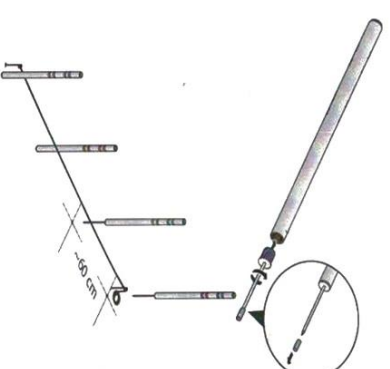

### Teile

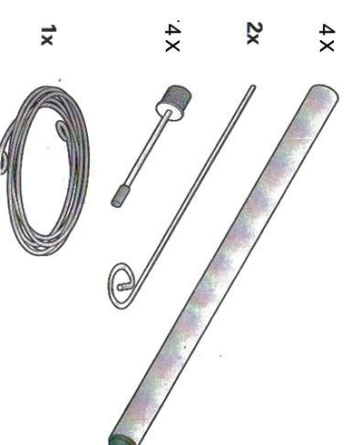



### Agility Tunnel

#### Teile

- 1. The second person should always accompany the first training. The assistant stand in front of the tunnel and pay attention that the dog also stands still. You go to the end of the tunnel and lure the dog with order, for example: "Tunnel", so that the dog runs through the tunnel. You should also sometimes praise the dog and offer a treat.

1x

8x

- 2. If the dog runs through the tunnel without a problem, you cannot begin with the second phase. You and your dog can stand at one end of the tunnel and send the dog with a chosen order and at the same time, you can run along the tunnel.

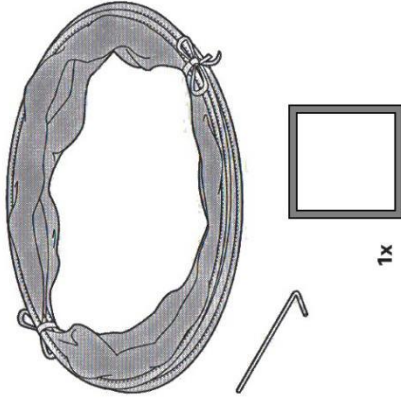

1x

### Tunnel Assembly Instructions

1. Remove the tunnel from the package bag.
2. Then loosen the ligaments around the tunnel to open. Caution! The tunnel is under tension and opens by itself.
3. Anchor the tunnel with the corresponding pegs as illustrated at the bottom.

#### ATTENTION!

It is very important that you not over train your dog. Particularly the puppies and young dogs have only very short concentration time.

If your dog has a problem with the steps, you might have proceed too fast. You should go back with the steps until the dog has mastered this step.

Attention that the training should always end with a positive experience.

